



Data Sheet

AS02008MR-R

Made for modern electronic devices, PUI Audio's **AS02008MR-R** is designed to be as thin as possible and recreate the human voice with good fidelity.

Features:

- IP65-rated face when properly installed
- Only 3mm thick
- 2.4g weight
- Designed for clear voice response

Speaker Specifications

Parameters	Values	Units
Rated Input Power	0.5	Watts
Max Input Power	0.8	Watts
Impedance	8 ± 15%	Ohms
Sensitivity @ 0.1W/0.1m (at 0.8, 1.0, 1.2, 1.5 kHz)	86 ± 3	dB
Resonant Frequency	500 ± 20%	Hz
Frequency Range (-10 dB)	350 ~ 20,000	Hz
Frame Material	Metal	-
Magnet Material	NdFeB	-
Weight	2.4	Grams
Ingress Protection Rating	IP65	-
Acceptable Soldering Methods	Hand Solder for ≤3 seconds	-
Buzz, Rattle, etc.	Shall not be audible with 2Vrms sine wave from 500 Hz to 4 kHz	-
Environmental Compliances	RoHS	-
Polarity	Cone shall move forward when a positive voltage is applied to the positive terminal	-
Storage Temperature	-30 ~ +70	°C
Operating Temperature	-20 ~ +55	°C

Measurement Method (Measured with 2V input with speaker mounted on IEC baffle)

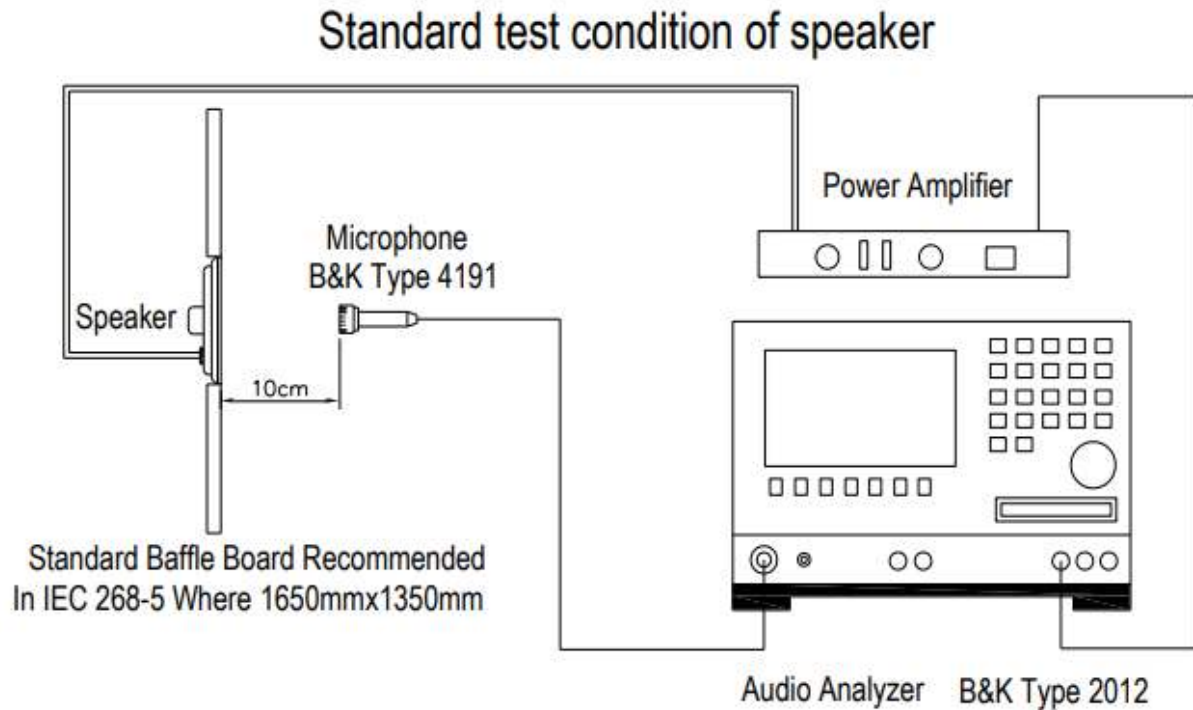

Typical Frequency Response (2V input measured at 10cm, two samples)

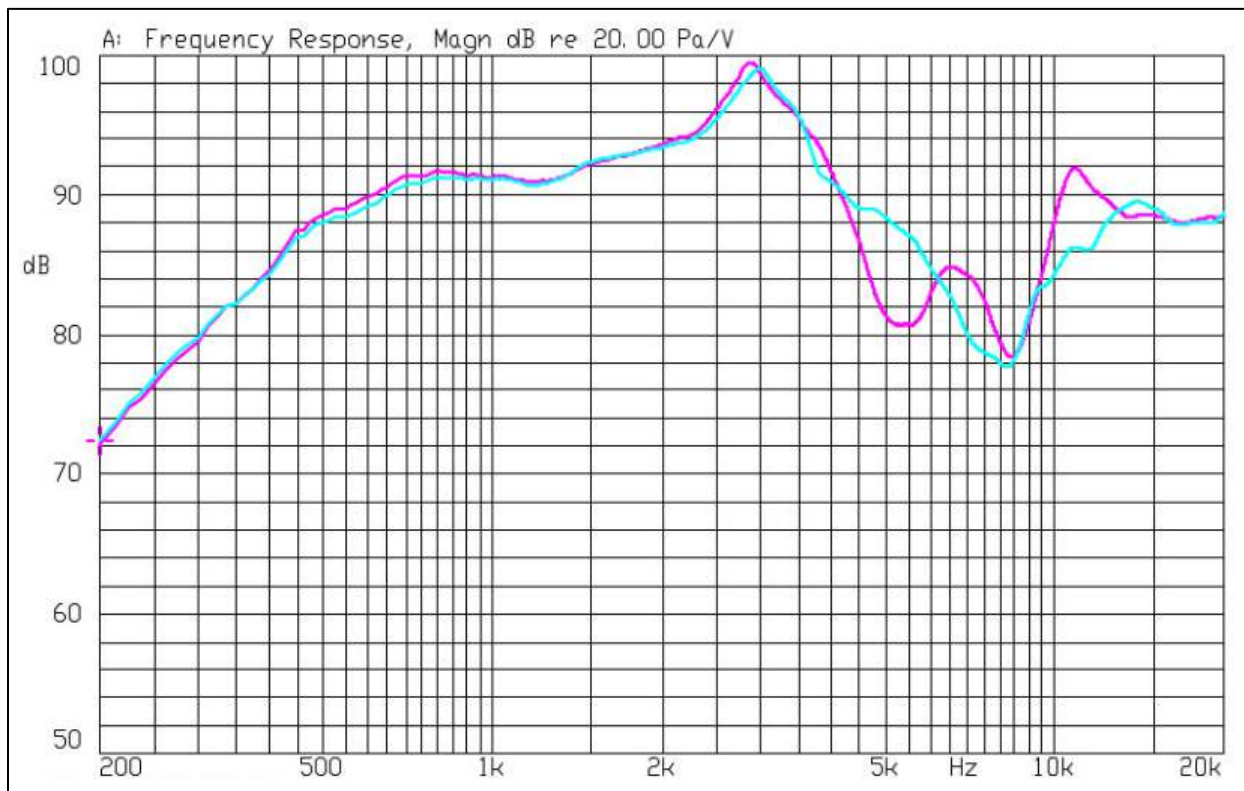

Reliability Testing

Type of Test	Test Specifications
High Temperature Test	96 hours at 70°C
Low Temperature Test	96 hours at -30°C
Humidity Test	96 hours at +40°C with relative humidity at 96%
Temperature Cycle Testing	The part shall be subjected to 12 cycles using the following procedure: Low temperature: -40°C±3°C High temperature: +80°C±3°C Cycle: 2 hours at High, 5 minutes High to Low, 2 hours at Low, 5 minutes Low to High
Vibration Test	10 to 55 to 10 Hz sine sweep, per minute @ 1.5mm amplitude 2 hours in each axis X, Y, and Z.
Shock Test	If applicable, describe conditions of test.
Drop Test	Drop speaker from a height of 1m onto a 20mm thick board 5 times
Load Test	2Vrms white noise is applied to the speaker for 96 hours

Call out how pass/fail conditions are determined after the reliability testing is complete

Dimensions (Right solder pad on left image below is positive +)

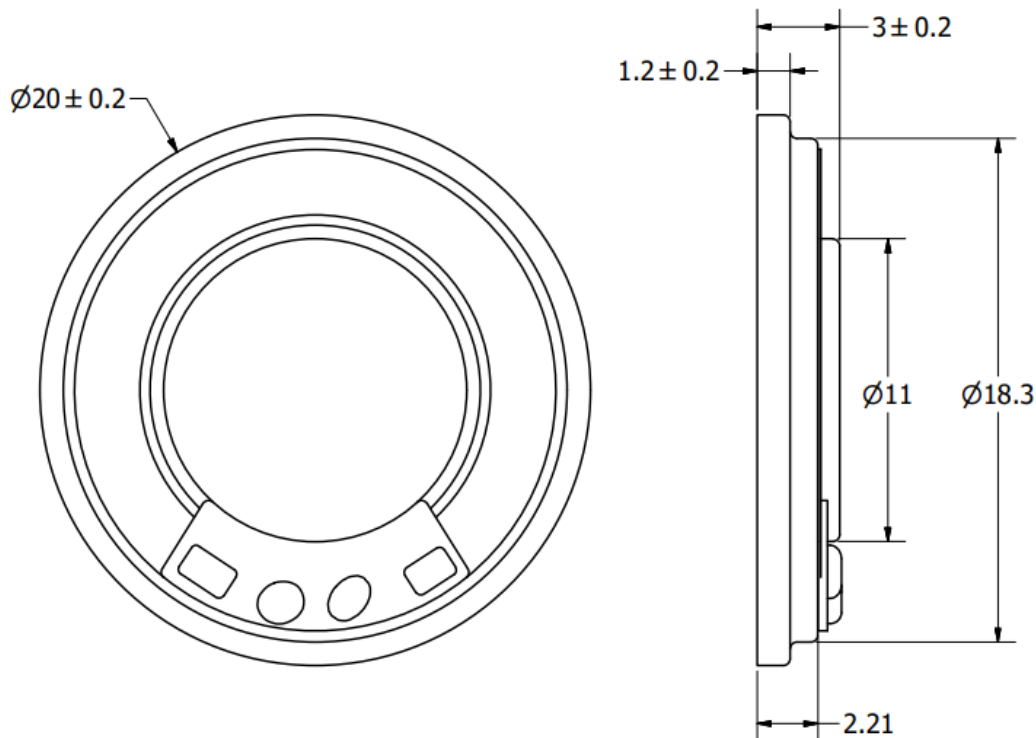

Specifications Revisions

Revision	Description	Date
-	Released from Engineering	5/2/2006
A	Revised to Inventor 3D Template	1/25/2008
B	Changed Plating on Speaker Frame	3/21/2016

Note:

1. Unless otherwise specified:
 - A. All dimensions are in millimeters.
 - B. Default tolerances are $\pm 0.5\text{mm}$ and angles are $\pm 3^\circ$.
2. Specifications subject to change or withdrawal without notice.