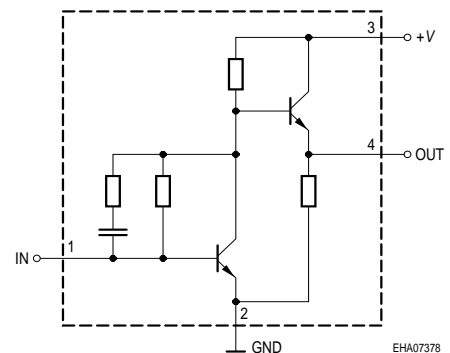
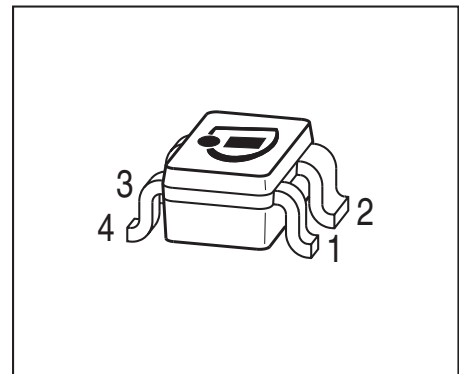

**Si-MMIC-Amplifier in SIEGET® 25-Technologie**

- Cascadable 50 Ω-gain block
- Unconditionally stable
- Gain  $|S_{21}|^2 = 18.5$  dB at 1.8 GHz (Appl.1)  
gain  $|S_{21}|^2 = 22$  dB at 1.8 GHz (Appl.2)  
 $IP_{3out} = +7$  dBm at 1.8 GHz ( $V_D=3V, I_D=9.4mA$ )
- Noise figure  $NF = 2.2$  dB at 1.8 GHz
- Typical device voltage  $V_D = 2$  V to 5 V
- Reverse isolation  $> 35$  dB (Appl.2)
- Pb-free (RoHS compliant) package

**Circuit Diagram**

**ESD (Electrostatic discharge) sensitive device, observe handling precaution!**

Type	Marking	Pin Configuration				Package
BGA427	BMs	1, IN	2, GND	3, +V	4, Out	SOT343

**Maximum Ratings**

Parameter	Symbol	Value	Unit
Device current	$I_D$	25	mA
Device voltage	$V_{D,+V}$	6	V
Total power dissipation $T_S = 120$ °C	$P_{tot}$	150	mW
RF input power	$P_{RFIn}$	-10	dBm
Junction temperature	$T_j$	150	°C
Ambient temperature range	$T_A$	-65 ... 150	
Storage temperature range	$T_{stg}$	-65 ... 150	

**Thermal Resistance**

Junction - soldering point <sup>1)</sup>	$R_{thJS}$	$\leq 295$	K/W
--	------------	------------	-----

<sup>1)</sup>For calculation of  $R_{thJA}$  please refer to Application Note Thermal Resistance

**Electrical Characteristics** at  $T_A = 25\text{ }^\circ\text{C}$ , unless otherwise specified.

Parameter	Symbol	Values			Unit
		min.	typ.	max.	
<b>AC characteristics</b> $V_D = 3\text{ V}$ , $Z_0 = 50\Omega$ , Testfixture Appl.1					
Insertion power gain $f = 0.1\text{ GHz}$ $f = 1\text{ GHz}$ $f = 1.8\text{ GHz}$	$ S_{21} ^2$	-	27	-	dB
Reverse isolation $f = 1.8\text{ GHz}$	S12	-	22	-	
Noise figure $f = 0.1\text{ GHz}$ $f = 1\text{ GHz}$ $f = 1.8\text{ GHz}$	NF	-	1.9	-	
Intercept point at the output $f = 1.8\text{ GHz}$	$IP_{3out}$	-	+ 7	-	dBm
Return loss input $f = 1.8\text{ GHz}$	$RL_{in}$	-	>12	-	dB
Return loss output $f = 1.8\text{ GHz}$	$RL_{out}$	-	>9	-	

### Typical configuration

**Appl.1**

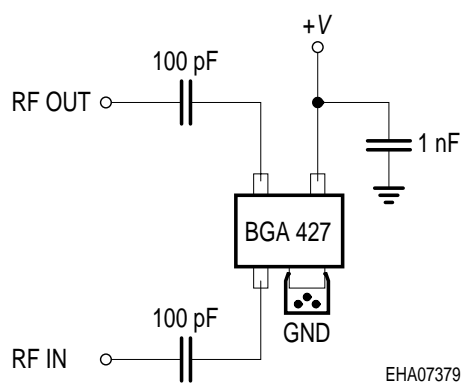

**Appl.2**

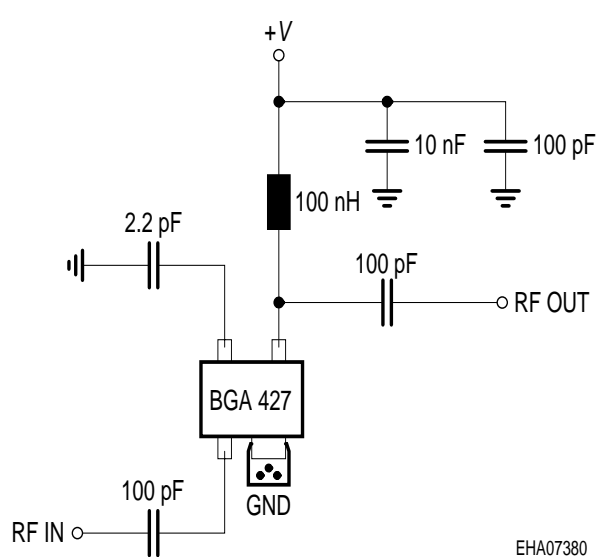

- Note: 1) Large-value capacitors should be connected from pin 3 to ground right at the device to provide a low impedance path (appl.1).  
 2) The use of plated through holes right at pin 2 is essential for pc-board-applications. Thin boards are recommended to minimize the parasitic inductance to ground.

**S-Parameters at  $T_A = 25\text{ }^\circ\text{C}$ , (Testfixture, Appl.1)**

$f$	$S_{11}$		$S_{21}$		$S_{12}$		$S_{22}$	
	MAG	ANG	MAG	ANG	MAG	ANG	MAG	ANG

 $V_D = 3V, Z_0 = 50\Omega$ 

0.1	0.1382	-38.3	24.821	164.9	0.0022	50.7	0.6435	174.8
0.2	0.1179	-16	24.606	158.9	0.0046	71.8	0.6278	166.9
0.5	0.1697	-20.8	22.236	135.2	0.0104	83.8	0.54	147.3
0.8	0.1824	-56.9	18.258	115.4	0.0169	94.8	0.4453	140.2
0.9	0.1782	-69.1	17.152	109.4	0.0194	97.3	0.4326	139.4
1	0.176	-80.6	15.786	104	0.0225	98.3	0.4129	138.1
1.5	0.1827	-133.5	10.923	84.9	0.0385	99.7	0.3852	139.6
1.8	0.1969	-156.1	9.029	77	0.0479	99.3	0.3917	139.3
1.9	0.2021	-162.8	8.486	74.7	0.0517	98.9	0.3946	138.8
2	0.2116	-167.7	8.015	72.3	0.0549	98.8	0.3991	138.3
2.5	0.2437	172.8	6.259	63	0.0709	97.1	0.4202	134.6
3	0.258	153.3	5.103	55	0.0892	96.9	0.4477	131

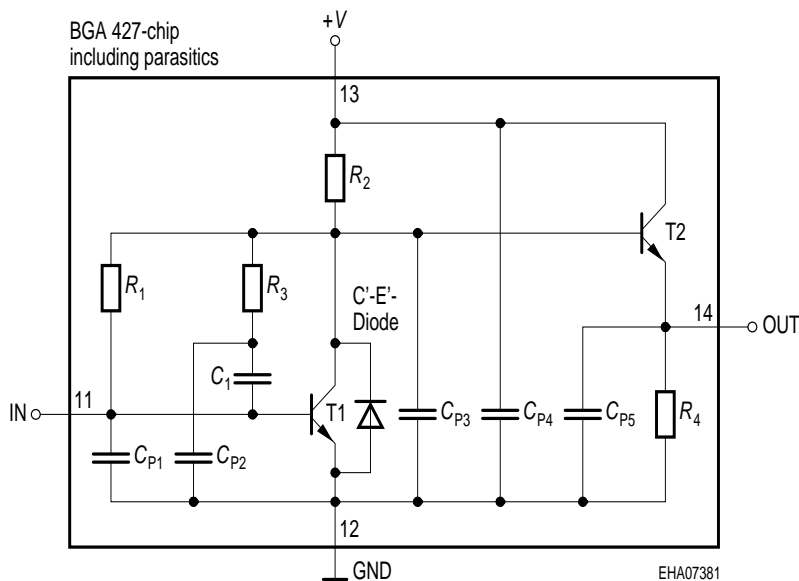
**Spice-model BGA 427**

T1	T501
T2	T501
$R_1$	14.5k $\Omega$
$R_2$	280 $\Omega$
$R_3$	2.4k $\Omega$
$R_4$	170 $\Omega$
$C_1$	2.3pF
$C_{P1}$	0.2pF
$C_{P2}$	0.2pF
$C_{P3}$	0.6pF
$C_{P4}$	0.1pF
$C_{P5}$	0.1pF
C'-E'-diode	T1

**Transistor Chip Data T1 (Berkley-SPICE 2G.6 Syntax) :**

IS =	0.21024	fA	BF =	83.23	-	NF =	1.0405	-
VAF =	39.251	V	IKF =	0.16493	A	ISE =	15.761	fA
NE =	1.7763	-	BR =	10.526	-	NR =	0.96647	-
VAR =	34.368	V	IKR =	0.25052	A	ISC =	0.037223	fA
NC =	1.3152	-	RB =	15	$\Omega$	IRB =	0.21215	A
RBM =	1.3491	$\Omega$	RE =	1.9289		RC =	0.12691	$\Omega$
CJE =	3.7265	fF	VJE =	0.70367	V	MJE =	0.37747	-
TF =	4.5899	ps	XTF =	0.3641	-	VTF =	0.19762	V
ITF =	1.3364	mA	PTF =	0	deg	CJC =	96.941	fF
VJC =	0.99532	V	MJC =	0.48652	-	XCJC =	0.08161	-
TR =	1.4935	ns	CJS =	0	fF	VJS =	0.75	V
MJS =	0	-	XTB =	0	-	EG =	1.11	eV
XTI =	3	-	FC =	0.99469	-	TNOM	300	K

**C'-E'-Diode Data (Berkley-SPICE 2G.6 Syntax) :**

IS =	2	fA	N =	1.02	-	RS =	20	$\Omega$
------	---	----	-----	------	---	------	----	----------

All parameters are ready to use, no scaling is necessary

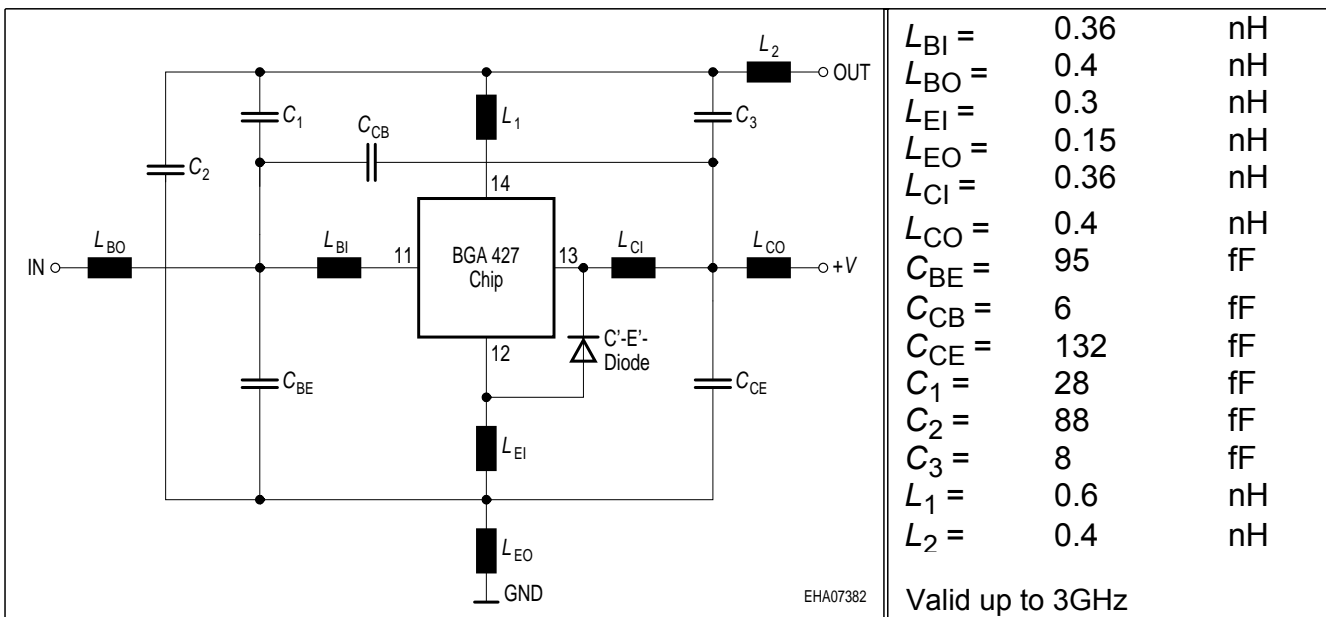
**Package Equivalent Circuit:**

Extracted on behalf of Infineon Technologies AG by:  
 Institut für Mobil-und Satellitentechnik (IMST)

For examples and ready to use parameters please contact your local Infineon Technologies distributor or sales office to obtain a Infineon Technologies CD-ROM or see Internet:  
<http://www.infineon.com/silicondiscretres>

**Insertion power gain  $|S_{21}|^2 = f(f)$**

**Noise figure  $NF = f(f)$**

$V_D, I_D = \text{parameter}$

$V_D, I_D = \text{parameter}$

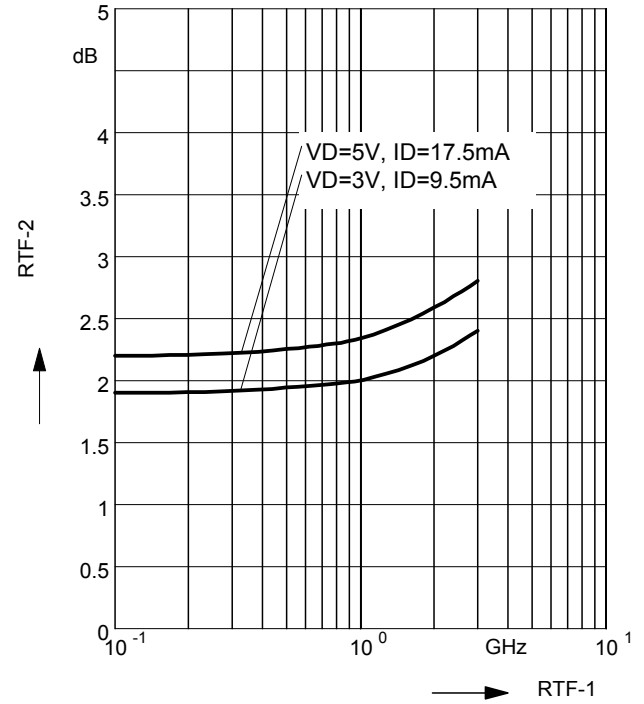
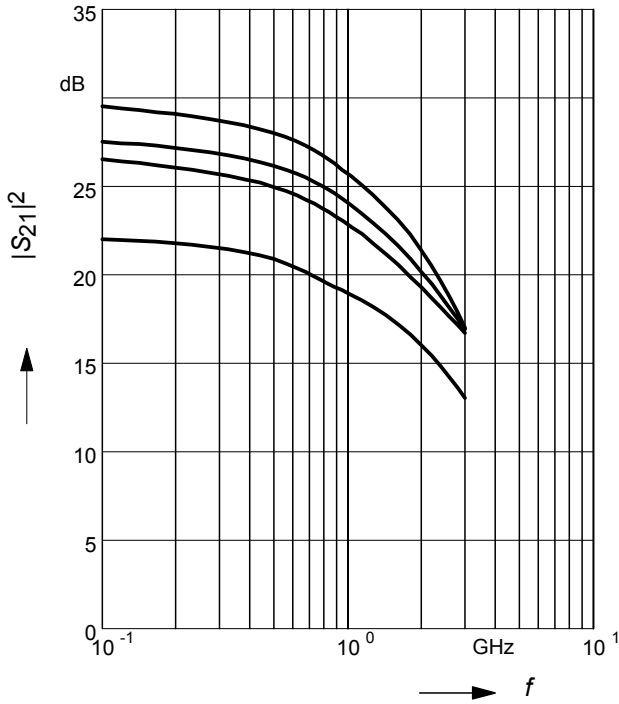

**Intercept point at the output**

$IP_{3out} = f(f)$

$V_D, I_D = \text{parameter}$

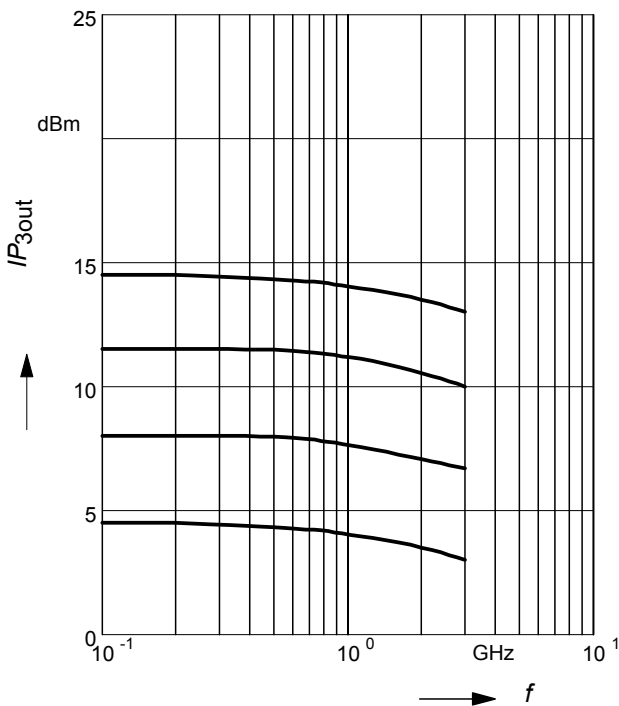

Package Outline

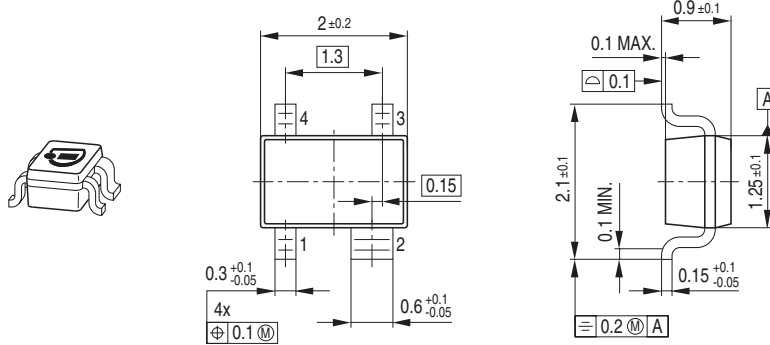

Foot Print

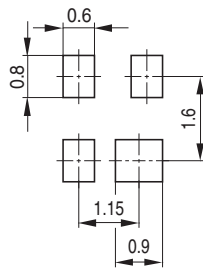

Marking Layout (Example)

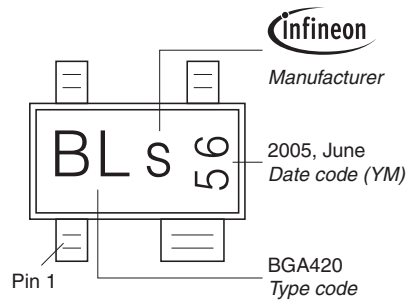

Standard Packing

Reel ø180 mm = 3.000 Pieces/Reel  
 Reel ø330 mm = 10.000 Pieces/Reel

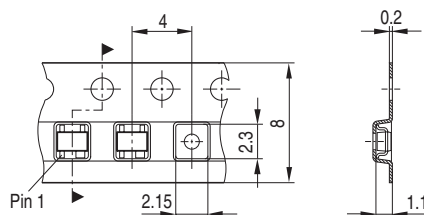

**Edition 2009-11-16**

**Published by  
Infineon Technologies AG  
81726 Munich, Germany**

**© 2009 Infineon Technologies AG  
All Rights Reserved.**

### **Legal Disclaimer**

The information given in this document shall in no event be regarded as a guarantee of conditions or characteristics. With respect to any examples or hints given herein, any typical values stated herein and/or any information regarding the application of the device, Infineon Technologies hereby disclaims any and all warranties and liabilities of any kind, including without limitation, warranties of non-infringement of intellectual property rights of any third party.

### **Information**

For further information on technology, delivery terms and conditions and prices, please contact the nearest Infineon Technologies Office ([<www.infineon.com>](http://www.infineon.com)).

### **Warnings**

Due to technical requirements, components may contain dangerous substances. For information on the types in question, please contact the nearest Infineon Technologies Office.

Infineon Technologies components may be used in life-support devices or systems only with the express written approval of Infineon Technologies, if a failure of such components can reasonably be expected to cause the failure of that life-support device or system or to affect the safety or effectiveness of that device or system. Life support devices or systems are intended to be implanted in the human body or to support and/or maintain and sustain and/or protect human life. If they fail, it is reasonable to assume that the health of the user or other persons may be endangered.