

FEATURES

- 2.5 voltage output, $\pm 0.6\%$ maximum**
- Wide input voltage range: 4.5 V to 33 V**
- Supply current: 1.4 mA maximum**
- Output voltage temperature coefficient: 50 ppm/ $^{\circ}\text{C}$ maximum**
- Line regulation: 50 ppm/V maximum**
- Load regulation: 100 ppm/mA maximum**
- Extended industrial temperature range: -40°C to $+85^{\circ}\text{C}$**
- Low cost**

GENERAL DESCRIPTION

The REF03 precision voltage reference provides a stable 2.5 V output, with minimal change for variations in supply voltage, ambient temperature, or loading conditions. Single-supply operation over an input voltage range of 4.5 V to 33 V with a current drain of 1 mA and good temperature stability is achieved using an improved band gap design. Primarily targeted at price sensitive applications, the REF03 is available in plastic PDIPs and surface-mount small outline plastic packages. For improved performance or -40°C to $+125^{\circ}\text{C}$ operation, see the [ADR03](#) data sheet.

PIN CONFIGURATION

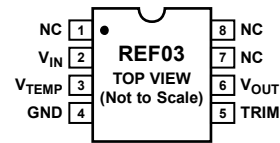

NOTES

1. NC = NO CONNECT. DO NOT CONNECT ANYTHING ON THESE PINS. SOME OF THEM ARE RESERVED FOR FACTORY TESTING PURPOSES.
2. TRIM PIN AND V_{TEMP} PIN SHOULD BE LEFT FLOATING IF THEY ARE NOT BEING USED.

Figure 1. 8-Lead PDIP (P-Suffix), 8-Lead SOIC (S-Suffix)

00372-001

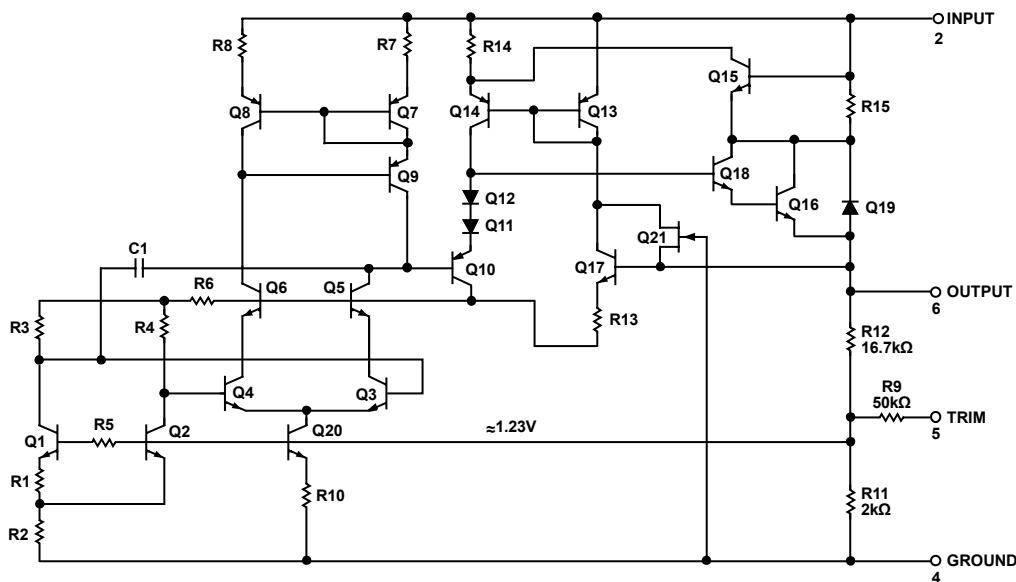

Figure 2. Simplified Schematic

00372-002

Rev. G

Information furnished by Analog Devices is believed to be accurate and reliable. However, no responsibility is assumed by Analog Devices for its use, nor for any infringements of patents or other rights of third parties that may result from its use. Specifications subject to change without notice. No license is granted by implication or otherwise under any patent or patent rights of Analog Devices. Trademarks and registered trademarks are the property of their respective owners.

TABLE OF CONTENTS

Features	1
General Description	1
Pin Configuration.....	1
Revision History	2
Electrical Specifications	3
Absolute Maximum Ratings.....	4
ESD Caution.....	4
Typical Performance Characteristics	5

REVISION HISTORY

6/07—Rev. F to Rev. G

Changes to Figure 1.....	1
Changes to Applications Section.....	7
Added Figure 15.....	7
Deleted Figure 21.....	7
Updated Outline Dimensions	9
Changes to Ordering Guide.....	10

6/04—Data Sheet changed from Rev. E to Rev. F

Updated Formatting.....	Universal
Changes to Simplified Schematic	1
Changes to Electrical Specifications	3
Changes to Ordering Guide.....	8

Applications.....	7
Generating an Adjustable Bipolar Voltage Reference.....	7
Generating a –2.5 V Reference.....	7
Boost Transistor Provides High Output Current.....	8
CMOS DAC Reference	8
Outline Dimensions	9
Ordering Guide	10

2/04—Data Sheet changed from Rev. D to Rev. E

Changes to Simplified Schematic	1
Changes to Electrical Specifications	2
Changes to Ordering Guide.....	3
Replaced TPC 1	4

8/03—Data Sheet changed from Rev. C to Rev. D

Updated format.....	Universal
Changes to Features	1
Changes to General Description	1
Replaced Wafer Test Limits.....	2
Changes to Electrical Specifications	2
Changes to Ordering Guide.....	3
Added Outline Dimensions	7

ELECTRICAL SPECIFICATIONS

@ $V_{IN} = 15\text{ V}$, $-40^{\circ}\text{C} \leq T_A \leq +85^{\circ}\text{C}$, unless otherwise noted.

Table 1.

Parameter	Symbol	Conditions	REF03G			Unit
			Min	Typ	Max	
Output Voltage	V_O	No load	2.485	2.500	2.515	V
Output Voltage Tolerance		No load		0.2	0.6	%
Output Voltage Temperature Coefficient ¹	TCV_O	$V_{IN} = 4.5\text{ V to }33\text{ V}$		10	50	ppm/ $^{\circ}\text{C}$
Line Regulation				20	50	ppm/V
Load Regulation			$I_L = 0\text{ mA to }10\text{ mA}$	0.002	0.005	%/V
Load Current (Sourcing)	I_L		10			ppm/mA
Load Current (Sinking)	I_S		-0.3	-0.5		%/mA
Short-Circuit Output Current	I_{SC}	Output shorted to ground		24		mA
Quiescent Supply Current	I_{SY}	No load		1.0	1.4	mA
Turn-On Settling Time ²	t_{ON}	To $\pm 0.1\%$ of final value		5		μs
Output Voltage Noise	e_n p-p	0.1 Hz to 10 Hz		6		$\mu\text{V p-p}$
Output Adjustment Range	ΔV_{TRIM}	$R_{POT} = 10\text{ k}\Omega$	± 6	± 11		%
Input Voltage Range			4.5	15	33	V
Temperature Voltage Output ³	V_T			620		mV

¹ TCV_O is measured by the endpoint method, and is equal to

$$\left| \frac{V(85^{\circ}\text{C}) - V(-40^{\circ}\text{C})}{(2.5 \times 10^{-6})(125^{\circ}\text{C})} \right| \text{ in ppm}/^{\circ}\text{C}$$

² Guaranteed by design.

³ Limit current in or out of Pin 3 to 50 nA and capacitance on Pin 3 to 30 pF.

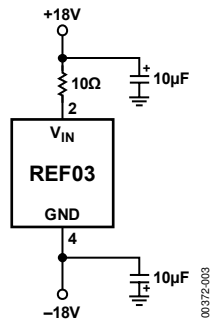

Figure 3. Burn-In Circuit

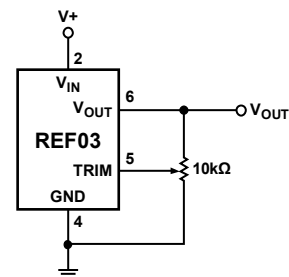

Figure 4. Output Voltage Trim Method

REF03

ABSOLUTE MAXIMUM RATINGS

$T_A = 25^\circ\text{C}$, unless otherwise noted. Absolute maximum ratings apply to both DICE and packaged parts, unless otherwise noted.

Table 2.

Parameter	Rating
Input Voltage	40 V
Output Short-Circuit Duration	Indefinite
Operating Temperature Range	
REF03G (P-Suffix, S-Suffix)	-40°C to $+85^\circ\text{C}$
Storage Temperature Range	-65°C to $+175^\circ\text{C}$
Junction Temperature Range	-65°C to $+175^\circ\text{C}$
Lead Temperature (Soldering, 10 sec)	300°C

Stresses above those listed under Absolute Maximum Ratings may cause permanent damage to the device. This is a stress rating only; functional operation of the device at these or any other conditions above those indicated in the operational section of this specification is not implied. Exposure to absolute maximum rating conditions for extended periods may affect device reliability.

Table 3. Package Thermal Resistance

Package Type	θ_{JA}^1	θ_{JC}	Unit
8-Lead PDIP (P-Suffix)	110	50	$^\circ\text{C}/\text{W}$
8-Lead SOIC (S-Suffix)	160	44	$^\circ\text{C}/\text{W}$

¹ θ_{JA} is specified for worst-case mounting conditions, that is, θ_{JA} is specified for the device in socket for a PDIP package. θ_{JA} is specified for the device soldered to printed circuit board for a SOIC package.

ESD CAUTION



ESD (electrostatic discharge) sensitive device. Charged devices and circuit boards can discharge without detection. Although this product features patented or proprietary protection circuitry, damage may occur on devices subjected to high energy ESD. Therefore, proper ESD precautions should be taken to avoid performance degradation or loss of functionality.

TYPICAL PERFORMANCE CHARACTERISTICS

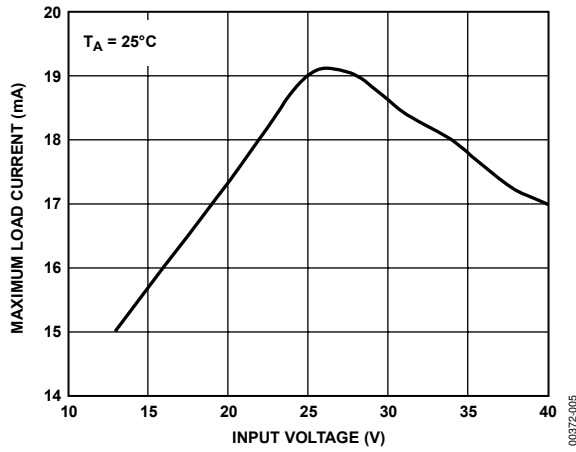

Figure 5. Maximum Load Current vs. Input Voltage

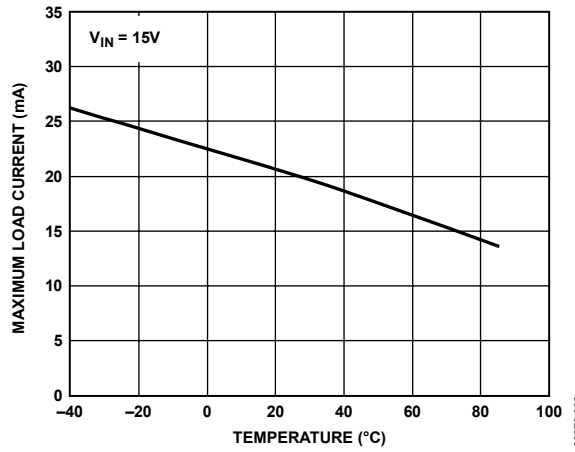

Figure 8. Maximum Load Current vs. Temperature

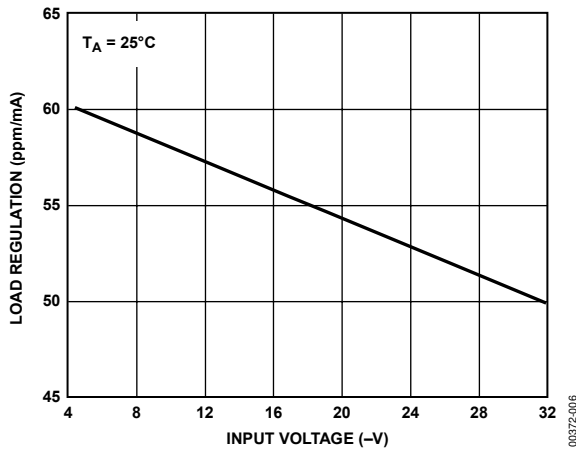

Figure 6. Load Regulation ($\Delta I_L = 10 \text{ mA}$) vs. Input Voltage

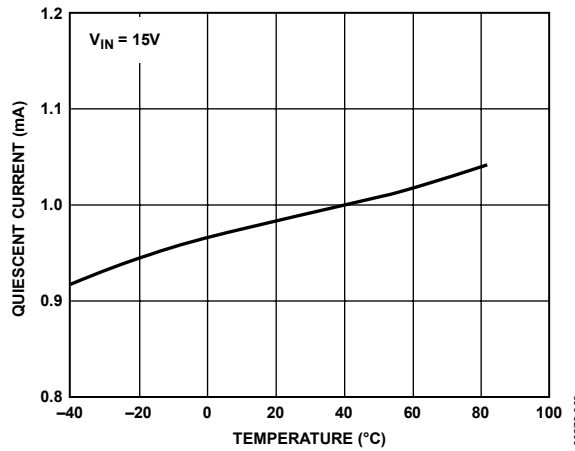

Figure 9. Quiescent Current vs. Temperature

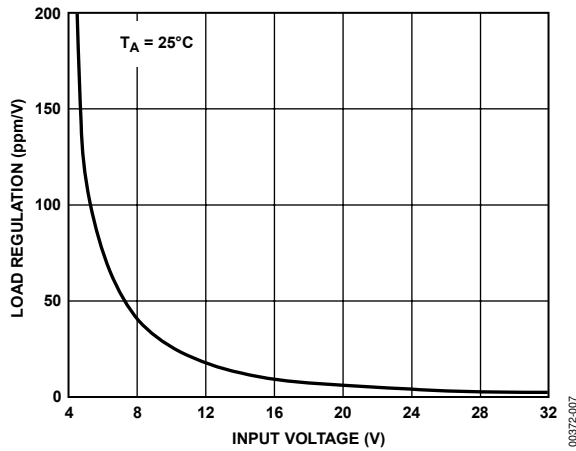

Figure 7. Line Regulation vs. Input Voltage

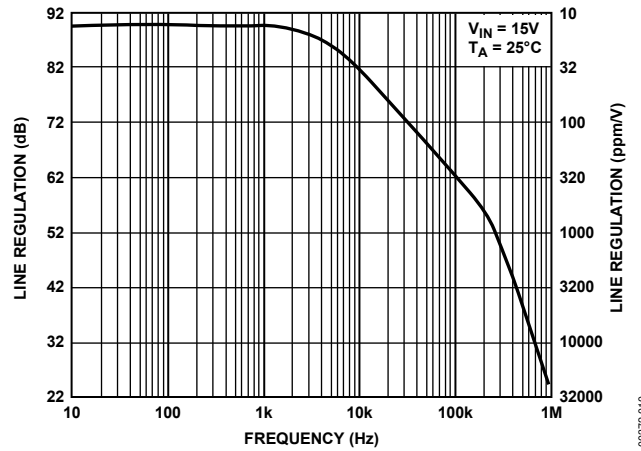

Figure 10. Line Regulation vs. Frequency

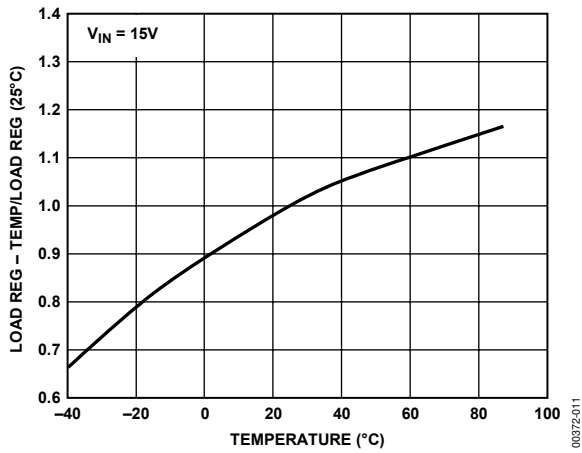

Figure 11. Normalized Load Regulation ($\Delta I_L = 10\text{ mA}$) vs. Temperature

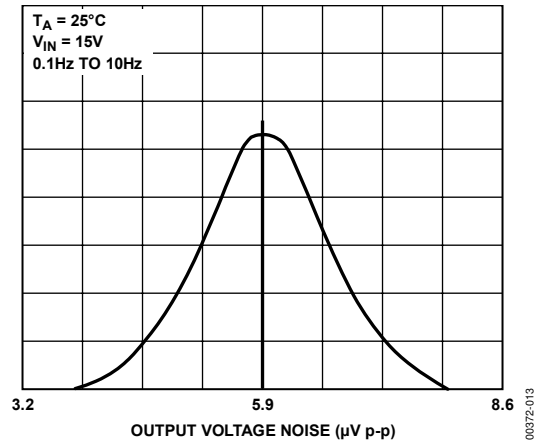

Figure 13. Typical Distribution of Output Voltage Noise

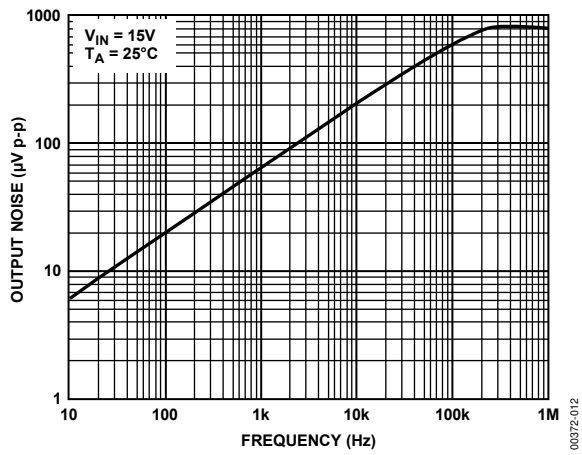

Figure 12. Wideband Output Noise vs. Bandwidth (0.1 Hz to Frequency Indicated)

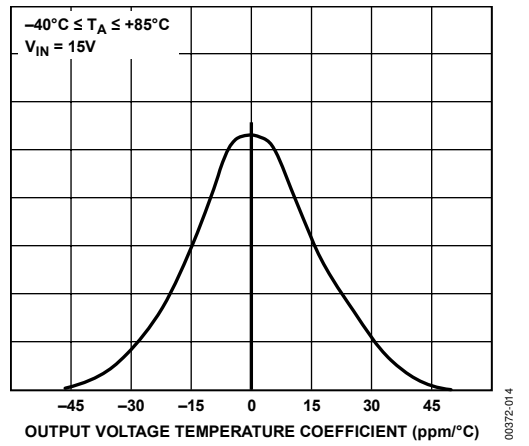

Figure 14. Typical Distribution of Output Voltage Temperature Coefficient

APPLICATIONS

The REF03 provides a stable 2.5 V output voltage with minimal dependence on load current, line voltage, or temperature. This voltage is typically used to set an absolute reference point in data conversion circuits, or in analog circuits such as log amps, 4 mA to 20 mA transmitters, and power supplies. The REF03 is of particular value in systems requiring a precision reference using a single 5 V supply rail.

Because an on-board operational amplifier is used to amplify the basic band gap cell voltage to 2.5 V, supply decoupling is critical to the transient performance of a voltage reference. The supply line should be bypassed with a 10 μF tantalum capacitor in parallel with a 0.01 μF to 0.1 μF ceramic capacitor for best results, as shown in Figure 15. The bypass capacitors should be located as close to the reference as possible. Inadequate bypassing can lead to instabilities.

Output bypass capacitors are not generally recommended. If necessary for high frequency output impedance reduction, the capacitance value used should be at least 1 μF .

If the V_{TEMP} and TRIM pins are not in use, then they should be left floating. However, when V_{TEMP} is being used for temperature compensation, it must be connected to a very high impedance node in the circuit, such as a noninverting input of a buffer.

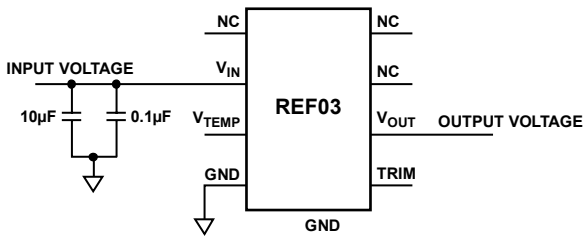

Figure 15. Basic Connections

00372-015

GENERATING AN ADJUSTABLE BIPOLAR VOLTAGE REFERENCE

There is often a requirement for an adjustable bipolar reference. A simple method of generating such a reference is to connect the output of the REF03 to an op amp in an adjustable gain configuration, as shown in Figure 16. The trimmable resistor is then used to generate the desired output voltage from -2.5 V to $+2.5\text{ V}$.

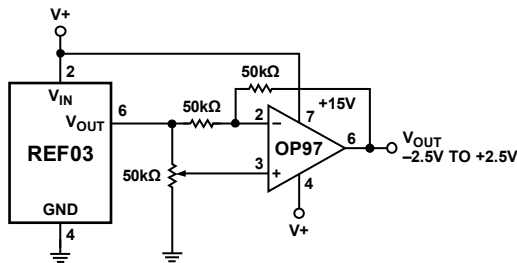

Figure 16. Adjustable Bipolar Reference

00372-016

GENERATING A -2.5 V REFERENCE

Often, there is a requirement for a negative reference voltage. The simplest method of generating a -2.5 V reference with the REF03 is to connect an op amp in a gain of -1 to the output, as shown in Figure 17. This provides both positive and negative 2.5 V references. Figure 18 shows another method of obtaining a negative reference, in which the current-output element is a PNP transistor, with the REF03 in a servo loop to ensure that the output remains 2.5 V below ground.

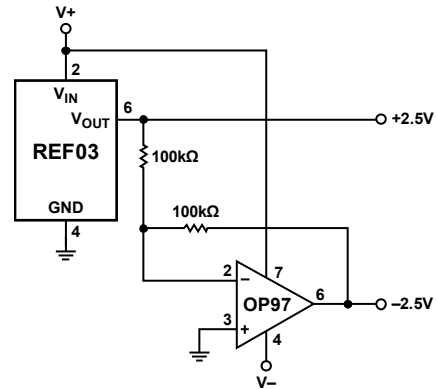

Figure 17. $\pm 2.5\text{ V}$ Reference

00372-017

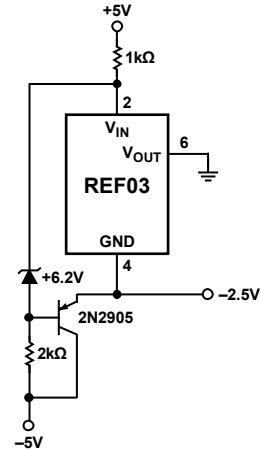

Figure 18. -2.5 V Reference

00372-018

REF03

BOOST TRANSISTOR PROVIDES HIGH OUTPUT CURRENT

When applications require more than 10 mA current delivery, an external boost transistor may be added to the REF03 to pass the required current without dissipating excessive power within the IC. The maximum current output to the system is bounded only by the capabilities of the boost transistor. Figure 19 shows this technique, with and without current limiting.

Current limiting may be used to prevent damage to the boost transistor. Figure 19A is an example of no current limit, while Figure 19B shows the limit that occurs when the voltage dropped across R2 exceeds one V_{BE} (0.6 V). The current limit is sensitive to the variations of the forward drop of the diodes and the PNP's V_{BE} with temperature, and also decreases with increasing temperature.

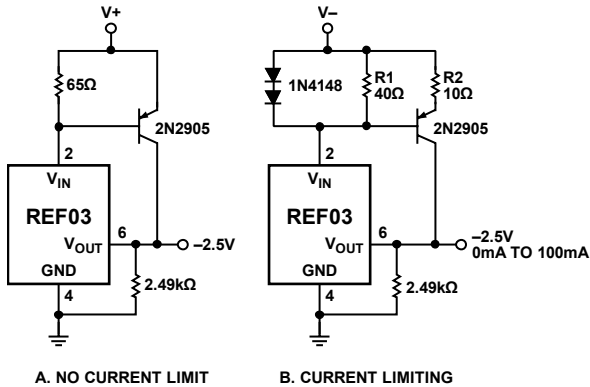

Figure 19. Output Current Boost

CMOS DAC REFERENCE

The REF03 makes an excellent reference for use with CMOS and bipolar DACs. Figure 20 shows the REF03 connected to the AD7393, a 12-bit CMOS DAC. An AD8603 with a common mode input range that extends to its positive rail can be a good combination with only 50 μ A of maximum current consumption.

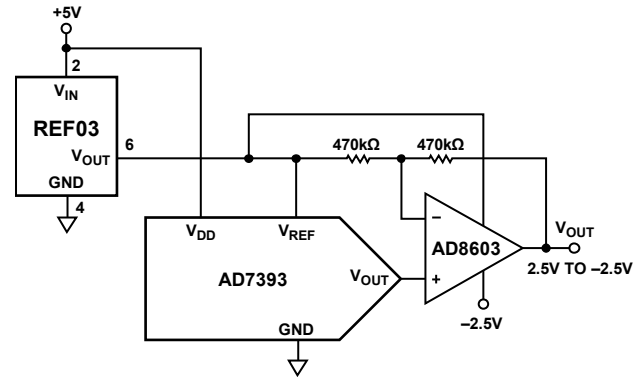
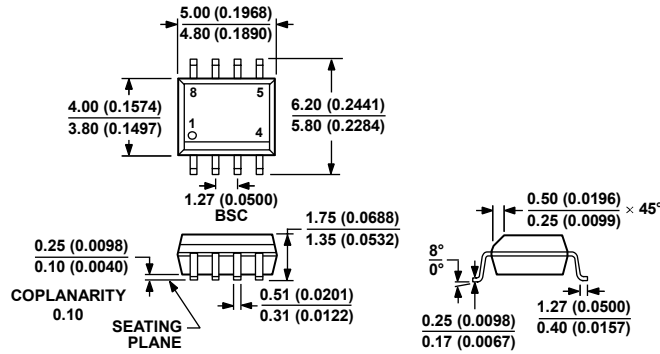

Figure 20. CMOS DAC Reference

00372-019

00372-020

OUTLINE DIMENSIONS



COMPLIANT TO JEDEC STANDARDS MS-012-AA
 CONTROLLING DIMENSIONS ARE IN MILLIMETERS; INCH DIMENSIONS
 (IN PARENTHESES) ARE ROUNDED-OFF MILLIMETER EQUIVALENTS FOR
 REFERENCE ONLY AND ARE NOT APPROPRIATE FOR USE IN DESIGN.

015407-A

Figure 21. 8-Lead Standard Small Outline Package [SOIC_N]
 Narrow Body
 (R-8)
 S-Suffix

Dimensions shown in millimeters and (inches)

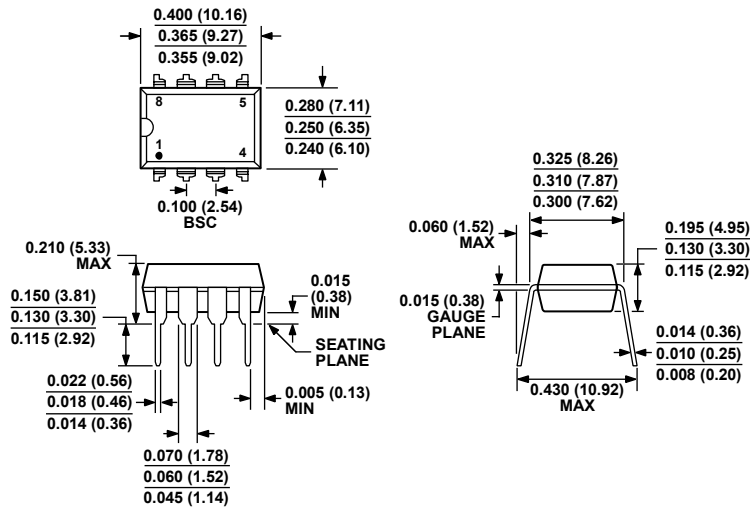

COMPLIANT TO JEDEC STANDARDS MS-001
 CONTROLLING DIMENSIONS ARE IN INCHES; MILLIMETER DIMENSIONS
 (IN PARENTHESES) ARE ROUNDED-OFF INCH EQUIVALENTS FOR
 REFERENCE ONLY AND ARE NOT APPROPRIATE FOR USE IN DESIGN.
 CORNER LEADS MAY BE CONFIGURED AS WHOLE OR HALF LEADS.

070686-A

Figure 22. 8-Lead Plastic Dual In-Line Package [PDIP]
 (N-8)
 P-Suffix

Dimensions shown in inches and (millimeters)

REF03

ORDERING GUIDE

Part Number	Initial Accuracy (%)	Temperature Coefficient	Temperature Range	Package Description	Package Option
REF03GP	0.2	10	-40°C to +85°C	8-Lead PDIP	N-8 (P-Suffix)
REF03GPZ ¹	0.2	10	-40°C to +85°C	8-Lead PDIP	N-8 (P-Suffix)
REF03GS	0.2	10	-40°C to +85°C	8-Lead SOIC_N	R-8 (P-Suffix)
REF03GS-REEL	0.2	10	-40°C to +85°C	8-Lead SOIC_N	R-8 (P-Suffix)
REF03GS-REEL7	0.2	10	-40°C to +85°C	8-Lead SOIC_N	R-8 (P-Suffix)
REF03GSZ ¹	0.2	10	-40°C to +85°C	8-Lead SOIC_N	R-8 (P-Suffix)
REF03GSZ-REEL ¹	0.2	10	-40°C to +85°C	8-Lead SOIC_N	R-8 (P-Suffix)
REF03GSZ-REEL7 ¹	0.2	10	-40°C to +85°C	8-Lead SOIC_N	R-8 (P-Suffix)

¹ Z = RoHS Compliant Part.

NOTES

REF03

NOTES