

NOTES

1. QUANTITY OF PRODUCTS : 1,600 PCS/1REEL
2. LEAD LENGTH

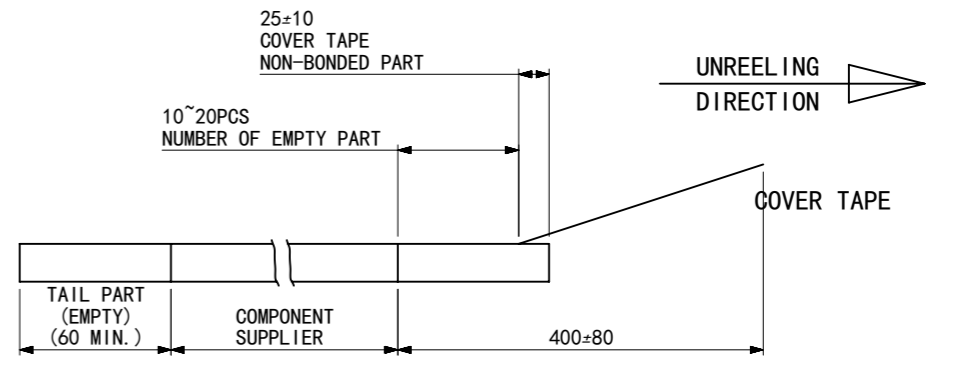

3. PEELING OFF FORCE OF COVER TAPE : 0.1N~0.59N(10.2~60gf)  
(PEELING DIRECTION AS BELOW)  
- PEELING OFF SPEED : 300mm/Min.(Ref.)

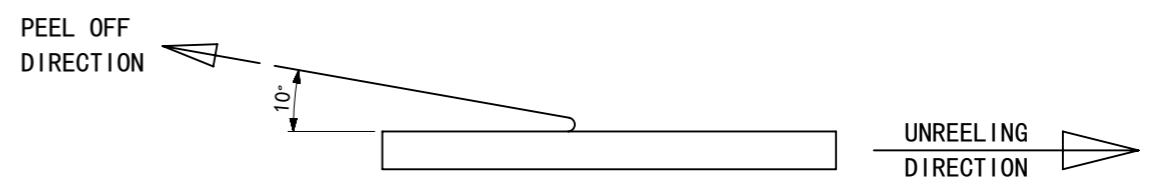

4. MATERIALS OF EMBOSSED CARRIER AND COVER TAPE :  
PET(POLYETHYLEN TEREPHTHALATE)

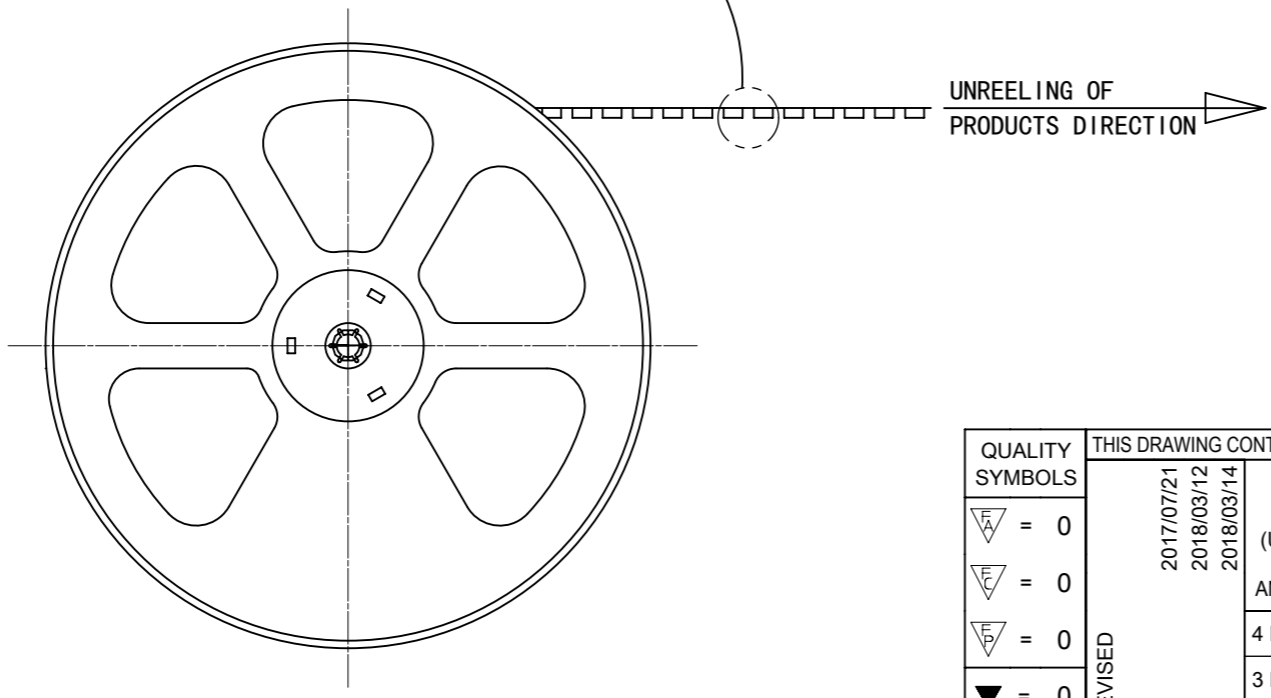
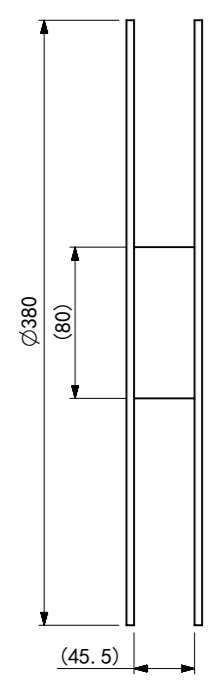

THIS DRAWING CONTAINS INFORMATION THAT IS PROPRIETARY TO MOLEX ELECTRONIC TECHNOLOGIES, LLC AND SHOULD NOT BE USED WITHOUT WRITTEN PERMISSION													
QUALITY SYMBOLS	REVISED	EC NO: 173450	DRWN: HJKANG01	CHK'D: SHCHU	APPR: YSKIM02	GENERAL TOLERANCES (UNLESS SPECIFIED)		DIMENSION UNITS	SCALE				
						4 PLACES ± 0.08	3 PLACES ± 0.08	mm	2:1				
▽A = 0						ANGULAR TOL ± 1.0 °				GENERAL MSD/NS 3IN2 HORIZONTAL TRAY TYPE			
▽E = 0						2 PLACES ± 0.08				PRODUCT CUSTOMER DRAWING			
▽F = 0						1 PLACE ± 0.08				SERIES	MATERIAL NUMBER	CUSTOMER	
▽ = 0						0 PLACES ± 0.08				201025	2010250214	GENERAL	
▽ = 0						DRAFT WHERE APPLICABLE MUST REMAIN WITHIN DIMENSIONS				DOCUMENT NUMBER	DOC TYPE	DOC PART	SHEET NUMBER
▽ = 0										2010250214	PSD	000	3 OF 3