



# MS<sup>2</sup><sup>™</sup> Modular Splicing System

## Instructions

# 3M™ MS<sup>2</sup>™ Modular Splicing System Instructions

## Contents

1.0	General .....	3
2.0	Module Description.....	3
2.1	Module Types.....	3
3.0	Tool Description.....	4
3.1	Main Splicing Rig Components .....	4
3.2	Hydraulic Crimping Units .....	4
3.3	Support Tube.....	4
3.4	Rig/Kit Components .....	5
3.5	3M™ MS <sup>2</sup> ™ Hand Tools .....	9
4.0	MS <sup>2</sup> Accessories.....	9
5.0	Basic Use of Tools and Module.....	11
5.1	Rig set-up.....	11
5.2	Wire Handling in Module.....	12
5.3	Crimping Modules .....	13
5.4	Basic Module Connections.....	15
5.5	Preterminated Module Connections and Tools to Crimp Them .....	17
6.0	Application .....	19
6.1	Inline Splicing (2-Bank) .....	19
6.2	Inline Splicing (3-Bank) .....	20
6.3	Inline Splicing (4-Bank) .....	20
6.4	Foldback Splicing (2-Bank).....	21
6.5	Foldback Splicing (2-Person) .....	23
6.6	Foldback Vertical Splicing (2-Bank) .....	23
6.7	Foldback Splicing (3-Bank).....	24
6.8	Unilength Splicing using 3M™ MS <sup>2</sup> ™ Super-Mate Module 4005-DPM.....	25
6.9	Bridge Splicing Using 3M™ MS <sup>2</sup> ™ Super-Mate Module 4005-DPM to a 3M™ MS <sup>2</sup> ™ Inline Super-Mini Splice 4000-D .....	26
6.10	Bridged Foldback Splicing .....	27
6.11	Half-Tapping Using the 3M™ MS <sup>2</sup> ™ Half Tap Module 4008.....	28
6.12	Half-Tapping Using 3M™ MS <sup>2</sup> ™ Super-Mini Module 4000-D or 3M™ MS <sup>2</sup> ™ Super-Mate Module 4005-DPM.....	30
6.13	Half-Tapping Using 3M™ MS <sup>2</sup> ™ Super-Mate Module 4005-DPM .....	31
6.14	Slack Removal .....	32
7.0	Maintenance .....	33
7.1	Module Reentry .....	33
7.2	Wire Insertion .....	33
7.3	Splice Conversion to 3M™ MS <sup>2</sup> ™ Modules 4005-DPM.....	34
8.0	Engineering .....	37
8.1	Job Planning.....	37
8.2	Moisture Protection.....	37
8.3	Fire Retardancy .....	37
8.4	Rebuilding Existing Splices .....	37
8.5	Rebuild Coding .....	37
8.6	Splice Planning .....	38
8.7	Load Coil Splice "L" (Apparatus).....	42
8.8	Loading .....	43
8.9	Deloading .....	43
8.10	Transfer – Access Splice/Facility Splice "F" (Modified Fold Back Configuration) .....	44
8.11	Cable Transfer – Conductor Termination.....	45
8.12	Cable Transfer – Using the Module .....	46
8.13	Taper Feeder Splice / Junction Splice "J" .....	47
8.14	Bridged Feeder Splice / Multiplied Straight Splice "S".....	48
	Appendix A: 3M-TMK Tool Mounting Kit.....	49
	Appendix B: 3M MS <sup>2</sup> ™ 4045 Universal Splicing Head Support Assembly.....	52

## 1.0 General

1.1 These instructions describe the 3M™ MS<sup>2</sup>™ Modular Splicing System, including modules, tools and applications. Applications are shown with dry modules only.

## 2.0 Module Description

2.01 MS<sup>2</sup> modules will:

- Connect and cut off up to 25 pairs of conductors from both the CO and field at one time, without the craftsperson having to strip insulation.
- Accept 22-28 AWG (0.6 - 0.32 mm) solid copper conductors insulated with PIC, pulp or paper with a maximum insulation O.D. of .065" (1.7 mm), G module series .053" (1.35 mm).
- Accept a mixture of wire gauges and insulation types in one module.

2.02 MS<sup>2</sup> modules have:

- Individual elements
- Individual cutoff blades
- Test entry ports
- Removable covers and bases for reentry

2.03 Encapsulated module versions (3M™ MS<sup>2</sup>™ Super Mini Splicing Module 4000-G, 3M™ MS<sup>2</sup>™ Super Mate Bridge Module 4005-GBM) and sealant boxes are available for moisture protection. Fire-retardant and specialty modules are also available.

### 2.1 Module Types

#### 2.11 Super-Mini

3M™ MS<sup>2</sup>™ Super Mini Test Module 4000D/TR

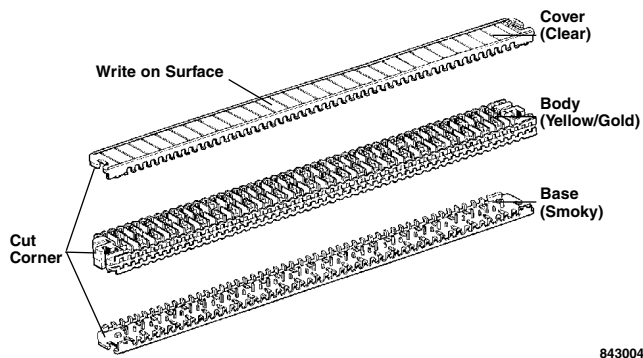

#### 2.13 Super-Mate Pluggable

3M™ MS<sup>2</sup>™ Super Mate Pluggable Module 4005-DPM/TR

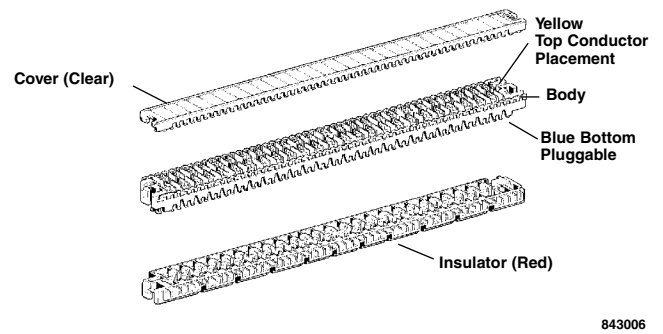

#### 2.12 Half-Tapping

3M™ MS<sup>2</sup>™ Super Mini Half-Tap Module 4008 D/TR

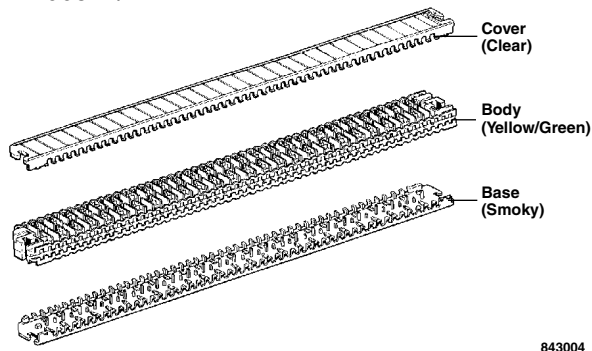

### 3.0 Tool Description

#### 3.1 Main Splicing Rig Components

3.1.1 The 3M™ MS<sup>2</sup> Splicing Head 4041 is used for initial termination of conductors in the modules. The splice head holds the conductors in their proper locations during the splicing procedure. The splice head holds module combinations for splicing.

- 1 Super-Mini
- 1 Super-Mini and 1 Super-Mate
- 2 Super-Mates
- 3 Super-Mates

3.1.2 It can be used to make connections with preterminated modules.

3.1.3 The splice head can be set up in a one or two splice head configuration for different applications.

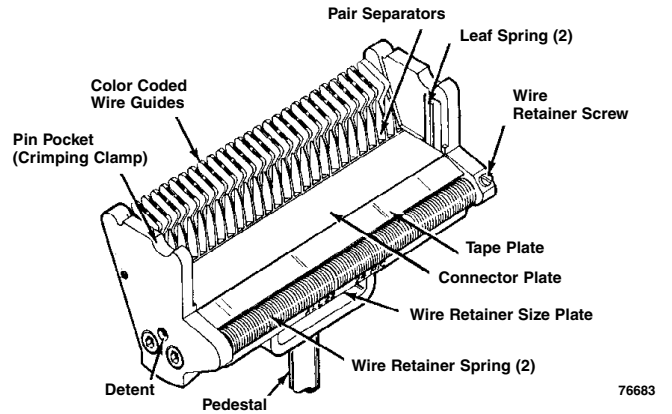

3M™ Splicing Head 4041

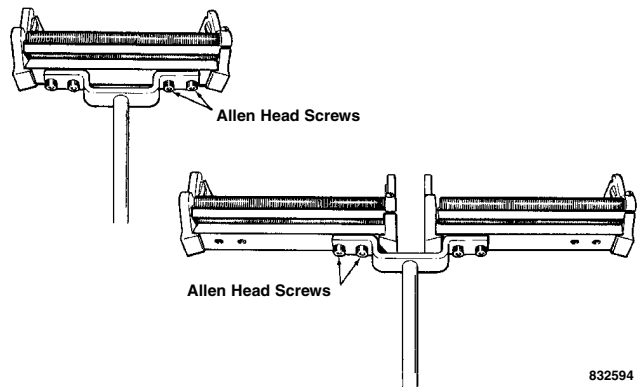

Double Head Set Up

#### 3.2 Hydraulic Crimping Units

3.2.1 One air-hydraulic and two hand-hydraulic crimping units can be used with the 4041 splice head to crimp the module.



3M™ MS<sup>2</sup>™ Crimping Clamp



3M™ MS<sup>2</sup>™ Air Crimping Unit 4030



3M™ MS<sup>2</sup>™ Hand Hydraulic Crimping Unit 4031



3M™ MS<sup>2</sup>™ Hand Hydraulic Crimper 4036-25

#### 3.3 Support Tube

3.3.1 The support tube and related components provide support for cables and tools while splicing is being done.

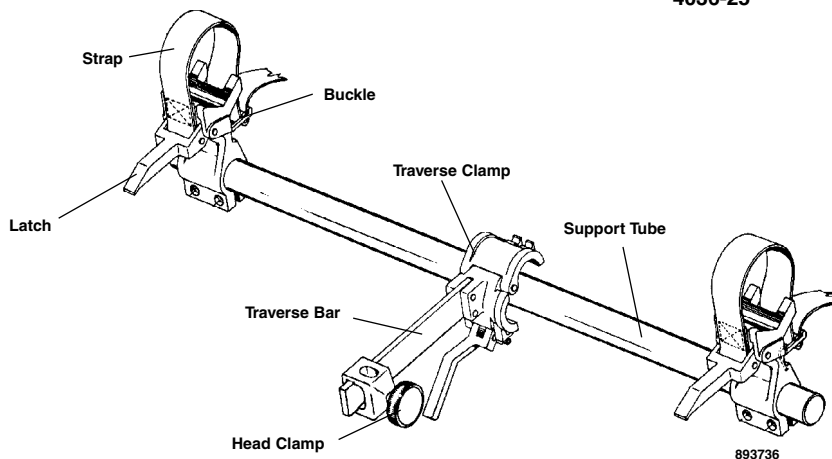









3.4 Rig/Kit Components

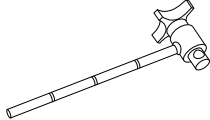

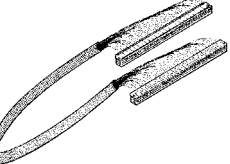

	Product Number	Description	4021-M2/36/NXG	4021-M2/36/TMK/NXG	4022-M2/NXG	4022-M2/TMK/NXG	4045-K2/36/FL/NXG	4045-K/36/NXG	4049-NXG	4026-A M2/TMK/NXG
	4049	Rig container/pail							1	
	4036-H	Tool holster							1	
	4028A	Rig case	1	1	1	1	1	1		
	4036-25	Hand crimper	1	1			1	1	1	
	4041-SH	Splice head holder							1	
	4040	<b>Splicing head assembly includes:</b>	2 each	2 each	2 each	2 each				
	4041-SPL	Splicing head	2	2	2	2				
	Spare-Rigs/PED	Pedestal	2	2	2	2				
	Spare-Rigs/TC-L	Traverse clamp assembly with long bar	2	2	2	2				

# 3M™ MS2™ Modular Splicing System Instructions

	Product Number	Description	4021- M2/36/NXG	4021- M2/36/TMK/NXG	4022- M2/NXG	4022- M2/TMK/NXG	4045- K2/36/FL/NXG	4045- K/36/NXG	4049-NXG	4026-A M2/TMK/NXG
	Spare-Rigs/HKCA	Head clamp	2	2	2	2				
	4041-P	Splicing head and "T" bar pedestal support					2	1	1	
	4046 CST	Collapsible support tube	1		1					
	4047	Pair test plug	1	1	1	1	1	1	1	1
	4051	Wire insertion tool	1	1	1	1	1	1	1	1
	4052T	Tester check comb	2	2	2	2	2	1	1	
	4053-PM	Separation tool	1	1	1	1	1	1	1	1
	4053	Cover removal tool								1

	Product Number	Description	4021-M2/36/NXG	4021-M2/36/TMK/NXG	4022-M2/NXG	4022-M2/TMK/NXG	4045-K2/36/FL/NXG	4045-K/36/NXG	4049-NXG	4026-A M2/TMK/NXG
	Spare-Rigs/STB	Short traverse bar	1	1	1	1				
	4045-SHSA	Universal splicing head support assembly					1	1		
	4049-VTB	Variable traverse brace assembly								
	4045	Support vise					1			
	4035A	Strand clamp					1			
	4044	Splice headframe adapter					1			
	4005-DPM/BTP/JMP	Super-mate bottom test plug jumper assembly								2
	4005-DPM/36PJT	Preterminated jumper assembly								2

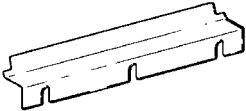
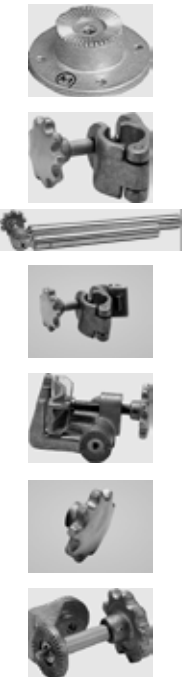
# 3M™ MS<sup>2</sup>™ Modular Splicing System Instructions

	Product Number	Description	4021- M2/36/NXG	4021- M2/36/TMK/NXG	4022- M2/NXG	4022- M2/TMK/NXG	4045- K2/36/FL/NXG	4045- K/36/NXG	4049-NXG	4026-A M2/TMK/NXG
	4270-A	Hand presser								1
	4041-2	Unilength hook	2	2	2	2	2	1	1	
	4041-RS	Rear spring holder	2	2	2	2	2	1	1	
	3M710-TMK10-A	<b>Tool mount kit includes:</b>		1 each		1 each				
	3M710-TMK10-A1	Base		1		1				
	3M710-TMK10-A2	Tool clamp kit		1		1				
	3M710-TMK10-A3	Swivel bar kit		1		1				
	3M710-TMK10-A4	Tube clamp		1		1				
	3M710-TMK10-A5	Vise kit		1		1				
	3M710-TMK10-A6	Swivel/knob		1		1				
	3M710-TMK10-A7	Tube/clamp kit		1		1				
	3M710-TMK10-A8	90° mount		1		1				
	Spare-Rigs/TSXA	Tube support extension	1		1					
	4046-CST	Collapsible support tube	1		1					



## 3.5 3M™ MS<sup>2</sup>™ Hand Tools

### 3.5.1 3M MS<sup>2</sup> Hand Presser 4270-A

Used for plugging combinations of two through seven modules together.

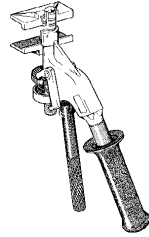

893724

3M™ MS<sup>2</sup>™ Hand Presser 4270-A

## 4.0 MS<sup>2</sup> Accessories

### 4.1 3M™ MS<sup>2</sup>™ Super-Mini Sealant Boxes 4075-S with Insertion Tool

Designed for moisture protection and reentry applications. The boxes can be applied to both foldback and inline splices. The 4075-S is designed to be used in all 2-wire 3M™ MS<sup>2</sup>™ Super-Mini 4000-D splice applications.

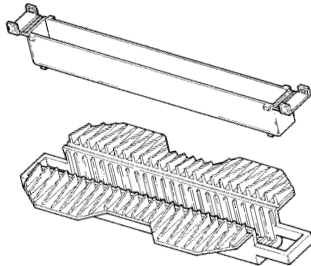

75516

### 4.2 3M™ MS<sup>2</sup>™ Sealant Boxes 4077 Series with Insertion Tool

The 4077 series sealant box is designed for use with the 3M™ MS<sup>2</sup>™ Module 4005-DPM.

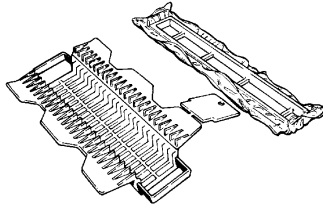

873600

- 4077-A - One Super-Mate Module
- 4077-B - One Super-Mate / One Super-Mini Module
- 4077-C - Two Super-Mate Modules
- 4077-D - Three Super-Mate Modules

### 4.3 3M™ MS<sup>2</sup>™ Wire Insertion and Cut Off Tool 4051

Individual conductors can be inserted into elements by using the 4051 wire insertion and cut off tool.

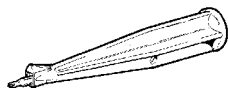

781181

### 4.4 3M™ MS<sup>2</sup>™ Half Tap Cover 4078-C

Used to protect wire ends after the half-taps has been cut out of the 3M™ MS<sup>2</sup>™ Super-Mini Half Tap Module 4008 in pulp/paper and pressurized PIC cable splices and vault splices.

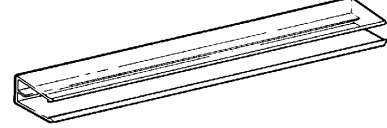

832569

### 4.5 3M™ MS<sup>2</sup>™ Separator Tool 4053-PM

- a. The 4053-PM separator tool is the only tool recommended for unplugging Super-Mate modules.

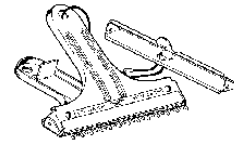

863422

- b. The enlarged pins of the tool distinguish the 4053-PM tool from the 3M™ MS<sup>2</sup>™ Cover Removal Tool 4053. **The 4053-PM tool cannot be used to remove covers or bases.**

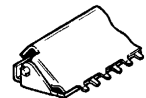
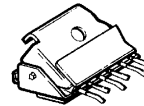

863423

3M™ MS<sup>2</sup>™ Separation Tool 4053-PM 3M™ MS<sup>2</sup>™ Cover Removal Tool 4053

### 4.6 3M™ MS<sup>2</sup>™ Pair Test Plug 4047

The 4047 pair test plug is a connector probe which permits pair checking through the test entry port without damaging wire insulation.

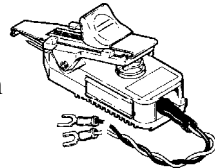

781247

### 4.7 3M™ MS<sup>2</sup>™ Bottom Test Plug 4005-DPM/BTP

Test plug assembly consisting of 4005-DPM module attached by a 24" jumper to a module designed to plug into the bottom of a 4000 or 4000 D/TR module.

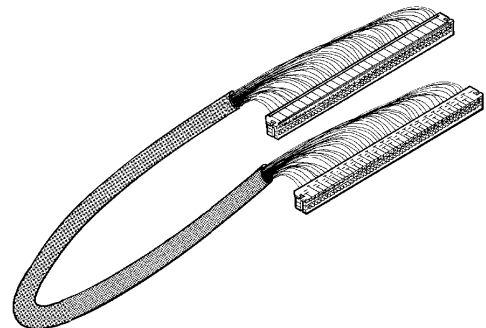

873540

# 3M™ MS<sup>2</sup>™ Modular Splicing System Instructions

## 4.8 3M™ MS<sup>2</sup>™ Module Maintenance Kit 4026

Contains the tools necessary for reentry of Super-Mini and Super-Mate modules.

### Kit Contents:

- 3M™ MS<sup>2</sup>™ Hand Presser 4270-A
- 3M™ MS<sup>2</sup>™ Wire Insertion and Cut Off Tool 4051
- 3M™ MS<sup>2</sup>™ Separator Tool 4053-PM
- 3M™ MS<sup>2</sup>™ Cover Removal Tool 4053
- 3M™ MS<sup>2</sup>™ Pair Test Plug 4047
- 3M™ MS<sup>2</sup>™ Jumper Assembly DPM/DPM (2)
- 3M™ MS<sup>2</sup>™ Bottom Test Plug Jumper Assembly 4005-DPM/BTP (2)



## 4.9 3M™ MS<sup>2</sup>™ Rear Spring Holder 4041

Allows the addition of a second set of wire retaining springs to the back of the 3M™ MS<sup>2</sup>™ Splicing Head 4041. Used in the conversion of Super-Mini splices to pluggable Super-Mate splices and for cutting in Super-Mate modules on through cables.

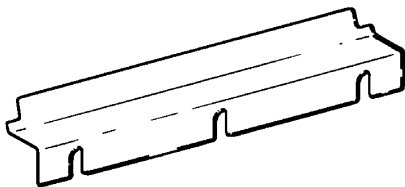

883640

## 4.10 3M™ MS<sup>2</sup>™ 2" Unilength Hook 4041-2

Attaches to all 3M™ MS<sup>2</sup>™ Splicing Heads to facilitate splicing in the unilength configuration.



883640

## 4.11 3M™ MS<sup>2</sup>™ Cover Removal Tool 4053

Recommended tool for the removal of 3M™ MS<sup>2</sup>™ Module Covers and Bases.

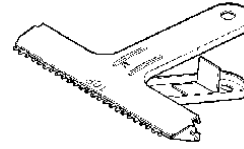

## 4.12 3M™ MS<sup>2</sup>™ Crimping Tool E9-BM

Crimps MS<sup>2</sup> module bases and covers onto connector bodies.

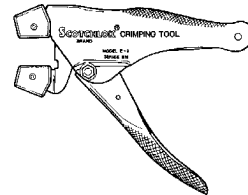

81203

## 4.13 3M™ MS<sup>2</sup>™ Check Comb 4052-T

Used to detect splicing errors prior to module crimping. Also used as a temporary module cover in certain splicing applications.

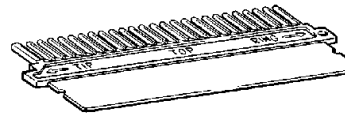

903882

## 4.14 3M™ MS<sup>2</sup>™ Preterminated Jumper Assemblies 4005-DPM

The 4005-DPM/PTJ Assembly consists of 24 AWG, PIC, unsheathed 25-pair binder group terminated on each end with a 4005-DPM module. Available in 36" (91.4 cm) or 72" (182.9 cm) lengths, the jumpers enable fast restoration of cut or damaged cables. Also used in maintenance of Super-Mate module splices where uninterrupted service is required.

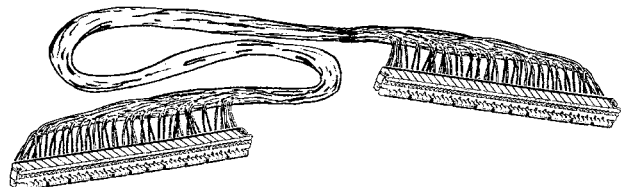

903882

## 5.0 Basic Use of Tools and Module

### 5.1 Rig set-up

5.1.1 Attach support tube to cable with appropriate splice opening

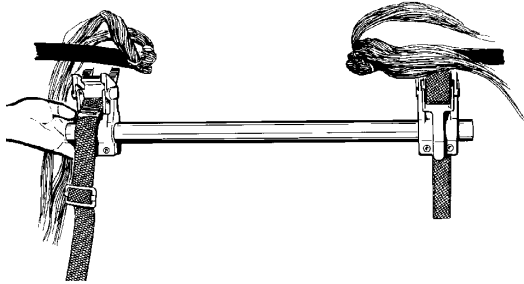

5.1.2 Attach buckle.

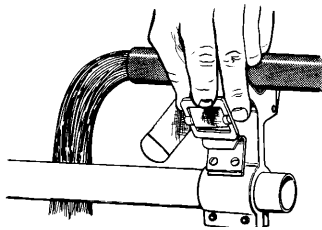

5.1.3 Tighten strap.

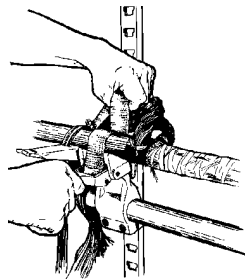

5.1.4 Attach traverse clamp assembly.

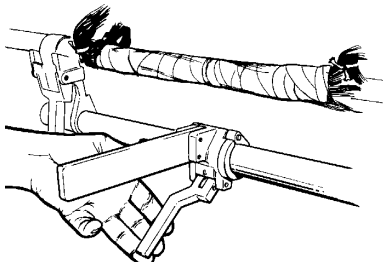

5.1.5 Slide head clamp on traverse bar.

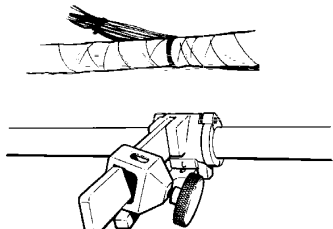

5.1.6 Insert pedestal with splice head or heads in head clamp. Double splice head is shown.

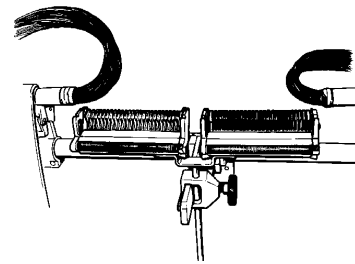

5.1.7 Locate splice head

a. Splice, back-bottom group first.

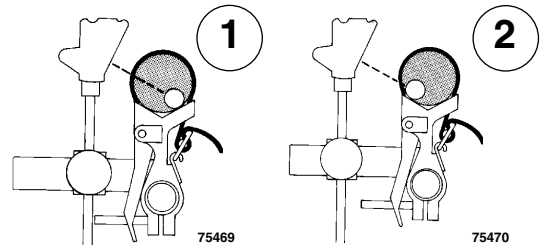

b. For inline splicing, adjust head(s) to group being handled.

c. Splice head should be higher than group being spliced.

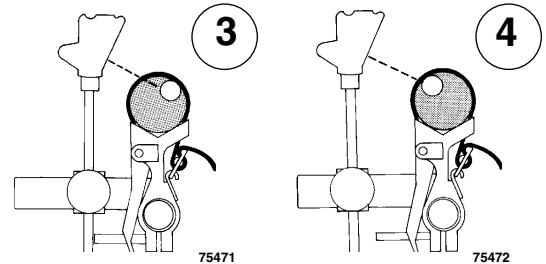

5.1.8 Set retainer spring to wire gauge of splice.

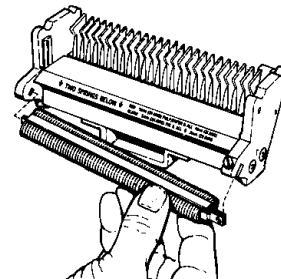

5.1.9 The gold splice adapter is used with all **Super-Mini Modules only.**

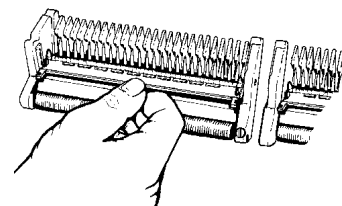

5.2 Wire Handling in Module

- 5.2.1 Using Super-Mini Module – Install base
- Using Super-Mate Module – Install body/insulator

Module cut corner towards the white/blue wire guide

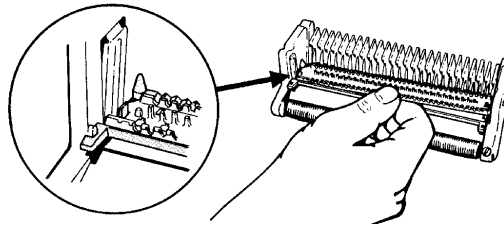

812117

- 5.2.2 Follow the color code according to the white wire guides. Wire pair to right side of corresponding color coded wire guide. Separate pair over pair separator, TIP (A) left and RING (B) right.

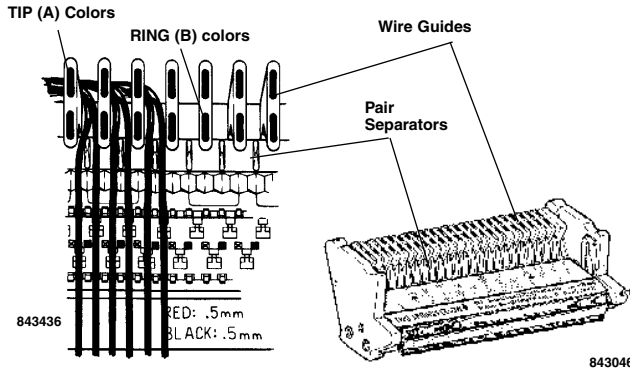

843046

- 5.2.3 Select a 25-pair group and place wires in module.

Draw wires snug into wire channels in module.

Secure in retainer springs.

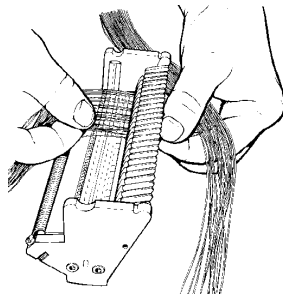

832596

**Thumb placed too far from splice head rear could cause twist in pair, resulting in “shiners.”**

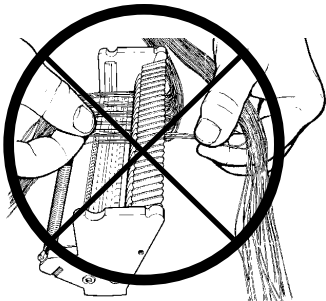

832597

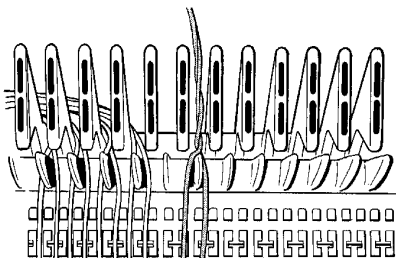

75436

- 5.2.4 Make sure all wires are lying flat in module channel.

Look for empty channels, 2 wires in one channel or reversed pairs with the check comb.

Slide comb left, only TIP (A) wires should show. Slide comb right, only RING (B) wires should show.

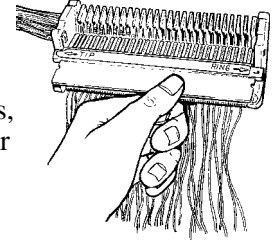

893745

- 5.2.5 Install next module component.

Place pairs from corresponding group.

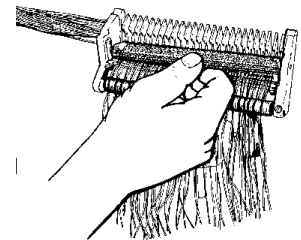

832600

- 5.2.6 Check for correct wire placement using the orange check comb.

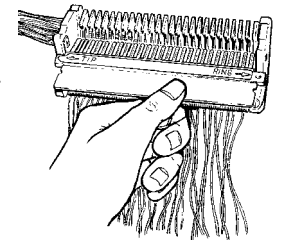

893745

- 5.2.7 Install module cover.

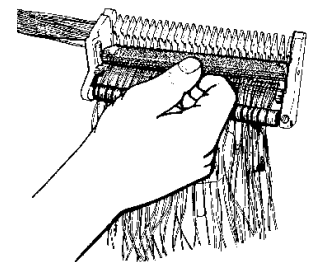

832601

### 5.3 Crimping Modules

#### 5.3.1 Hydraulic Hose Crimpers

- a. Hydraulic hose can face left or right. Rest crimper on splice head with legs angled toward you.
- b. Rotate the clamp until it is locked in an upright position by the detents.

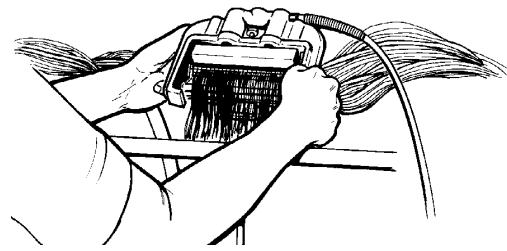

75442

Adjust for proper height

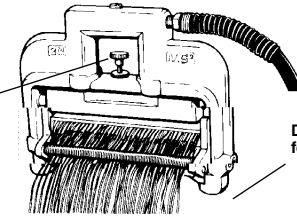

Detents can be adjusted for tightness

781167

#### 5.3.1.2 Crimping Hose Hydraulic Pumps

##### a. Hand/Hose Hydraulic Pump.

1. Always position output end **level or lower than rear.**



2. Close the pressure release valve and operate the pump handle until the audible bypass is heard, then pump three additional times. Leave the crimping clamp closed until the cut conductors are removed.

##### b. Air/Hydraulic Pump

1. Always position output end **level or lower than rear.**



2. Operate the PRESS/RELEASE control to the PRESS position and hold until the pressure bypass is heard to operate. This signifies a completed crimp. Leave crimping clamp closed until the cut conductors are removed.

#### 5.3.1.3 Remove one-fourth to one-third of the cut conductors at a time by lifting them straight up from the retainer spring.

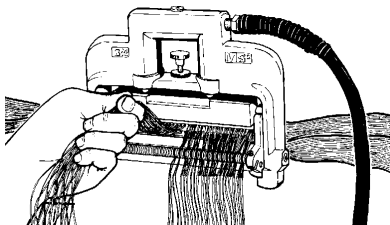

781170

#### 5.3.1.4 Remove crimping clamps.

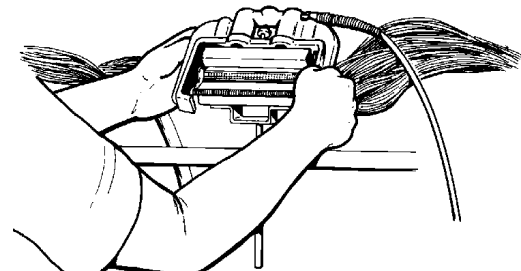

75446

**Note:** To avoid damaging the retainer spring, do not attempt to remove all the conductors at once.

**Note:** An adjustment screw on crimping clamp can be set to limit return on crimping bar. This screw can be adjusted to reduce the number of strokes required for crimping a two-wire splice when using the hand pump, but must be completely backed off for crimping 3-wire bridge splices.

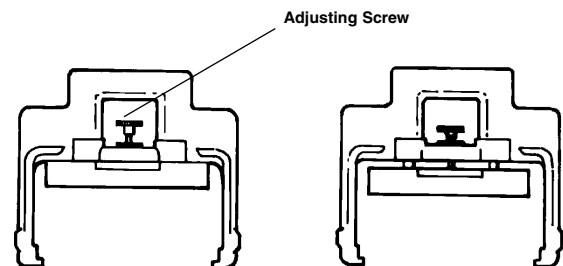

75447

# 3M™ MS<sup>2</sup>™ Modular Splicing System Instructions

## 5.3.2 3M™ MS<sup>2</sup>™ Hand Hydraulic Crimper 4036-25

5.3.2.1 The 4036-25 crimper is a self-contained, pistol-gripped crimper designed to crimp 3M™ MS<sup>2</sup>™ Splicing and Pluggable Modules 4000-D and 4005-DPM series.

- a. Rapid advance lever
- b. Fixed handle
- c. Moveable handle
- d. Release trigger
- e. Press bar
- f. Ball plungers

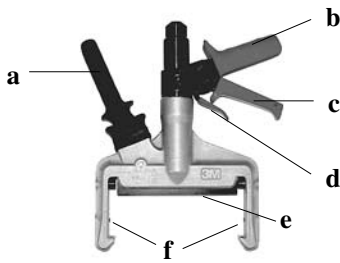

5.3.2.2 Use standard MS<sup>2</sup> splicing practice to prepare cable, set up splice head, and wire module.

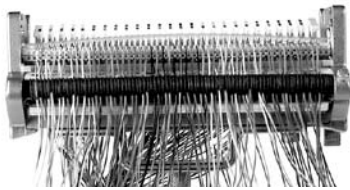

5.3.2.3 Place crimper rockers into yoke of splice head. Rotate crimper until it locks into upright position. Adjust ball plungers (indicated by arrows) in or out with standard screwdriver if necessary to allow rotation and locking.



5.3.2.4 Using rapid advance lever, advance press bar until it presses down firmly on the module.



5.3.2.5 Pump handle until pressure bypass operates, indicating module is fully crimped.



5.3.2.6 Remove cut off conductors by lifting straight up from retainer spring and pulling gently.



5.3.2.7 Pull release trigger to reset press bar.



5.3.2.8 Remove crimper by reversing rotation described above. Remove module from splice head.



5.3.2.9 Periodically (about every 1000 cycles) lubricate moving parts of the rotating handle with a lightweight machine oil or water displacing lubricant.

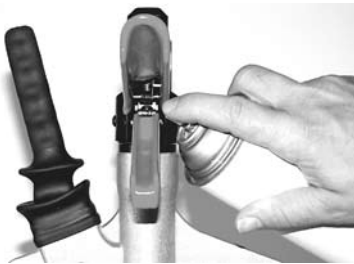

5.3.2.10 To guard against general corrosion, spray blackened steel surfaces with a lightweight machine oil or water displacing lubricant. This is especially important before extended periods of storage.



*Note: Carefully follow safety, health and environmental information given on product label or the MSDS sheet.*

5.3.2.11 Crimpers may be cleaned by brushing carefully with a citrus-based cleaning solution. Do not immerse the entire crimper in the solution. After cleaning, wipe dry and lubricate as described in preceding paragraphs.



*Note: Carefully follow safety, health and environmental information given on product label or the MSDS sheet.*

## 5.4 Basic Module Connections

### 5.4.1 Straight Splice

This connection is a Central Office (CO) feeder group to a field/house group made with a 3M™ MS<sup>2</sup>™ Super Mini Module 4000 module series.

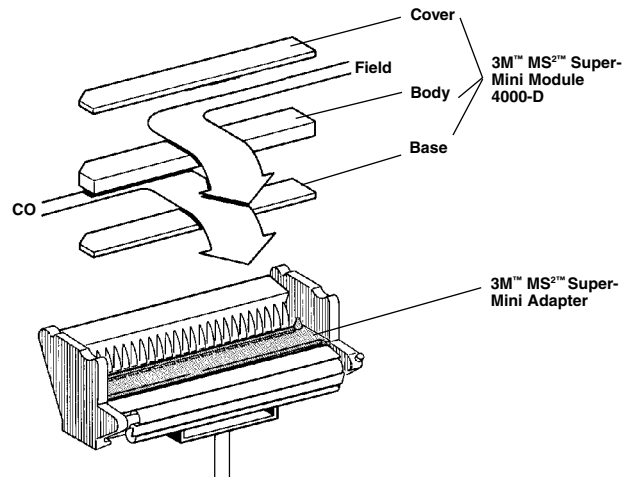

### 5.4.2 Half-Tap Splice

- a. This is a connection to an existing group (with slack) and a group to tap on to it. Typical example is an old central office through cable and a new central office cable to replace it.

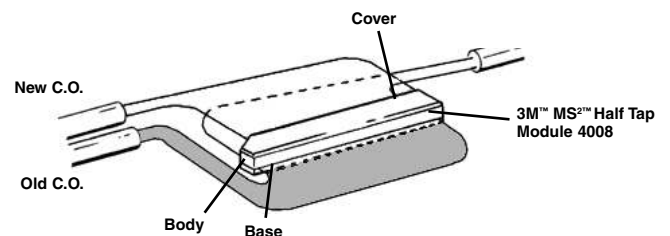

# 3M™ MS<sup>2</sup>™ Modular Splicing System Instructions

- b. To remove half-tapped cable, use a flush cut offset pair of pliers to allow one conductor to be cut at a time. Care should be taken not to short against adjacent cut conductors.

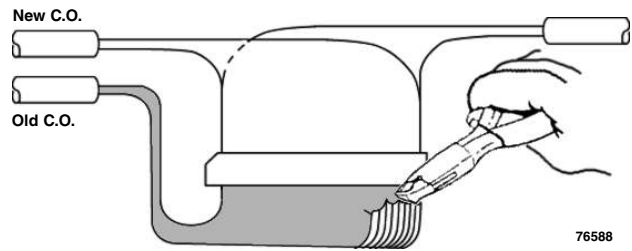

## 5.4.3 One-Way Pluggable Connection

This combination connects two conductor groups by plugging the 3M™ MS<sup>2</sup>™ Super-Mate Module to the body top of the 3M™ MS<sup>2</sup>™ Super-Mini Module.

Conductors can be terminated either in the body bottom or body top of the Super-Mini module.

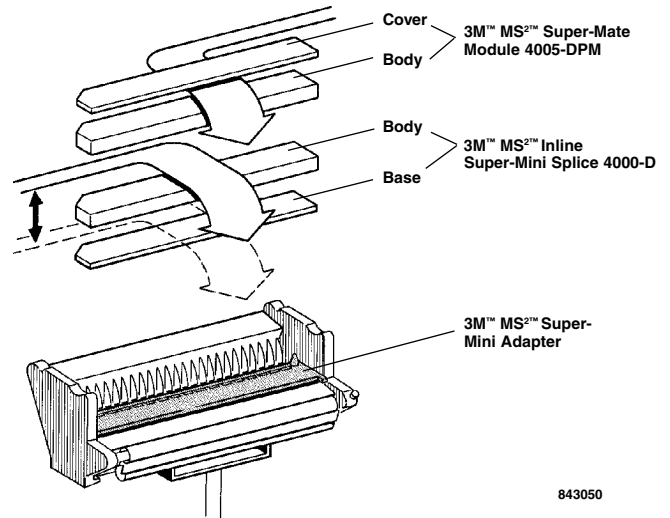

## 5.4.4 Pluggable Bridge Connection

This combination makes a three conductor connection (bridged) by plugging a Super-Mate module to the body top of the Super-Mini module.

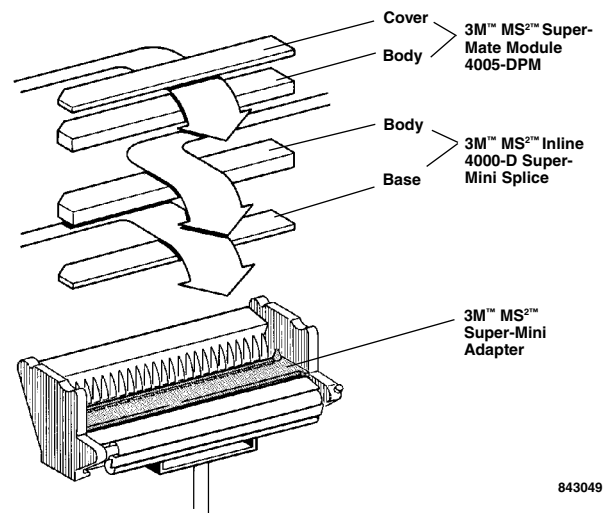

## 5.4.4 Two-Way Pluggable Connection

This combination makes a two-conductor connection by plugging a Super-Mate module to either the body top or body bottom of another Super-Mate module.

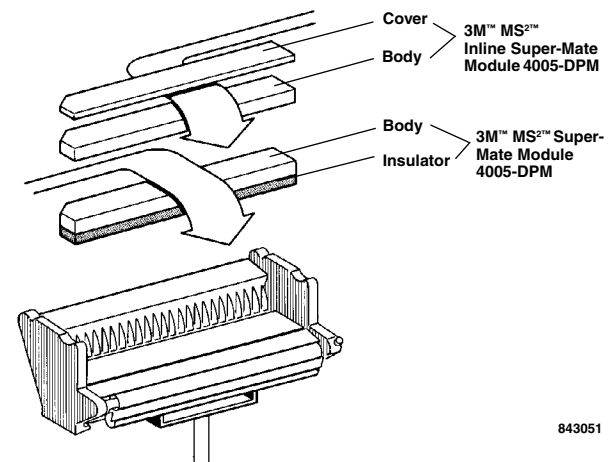



**5.5 Preterminated Module Connections and Tools to Crimp Them**

Preterminated 3M™ MS<sup>2</sup>™ Super-Mate Modules can be used as pluggable units with modules during splice construction and modules in existing splices

5.5.1 Pretermination of one Super-Mate module

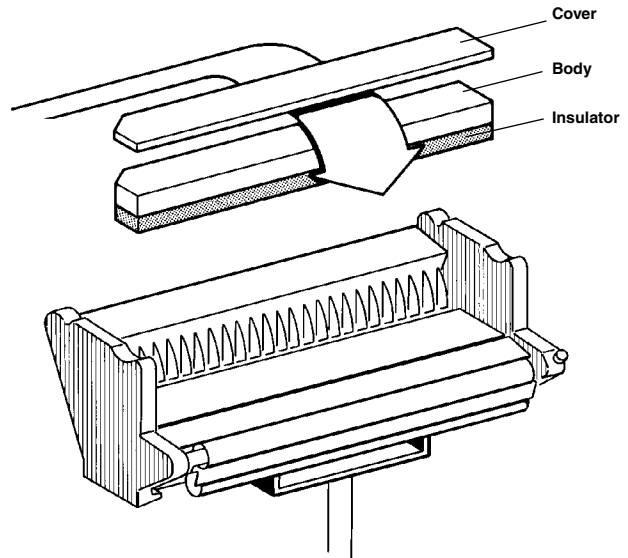

843052

5.5.2 Preterminated Super-Mate, plugged to a new 3M MS<sup>2</sup> Super-Mini Splice.

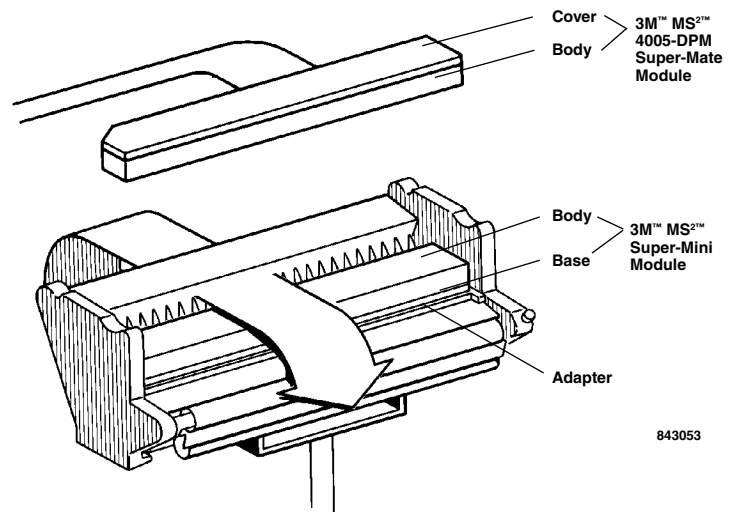

3M™ MS<sup>2</sup>™  
4005-DPM  
Super-Mate  
Module

3M™ MS<sup>2</sup>™  
Super-Mini  
Module

843053

5.5.3 Preterminated Super-Mate, plugged into a new Super-Mate splice.

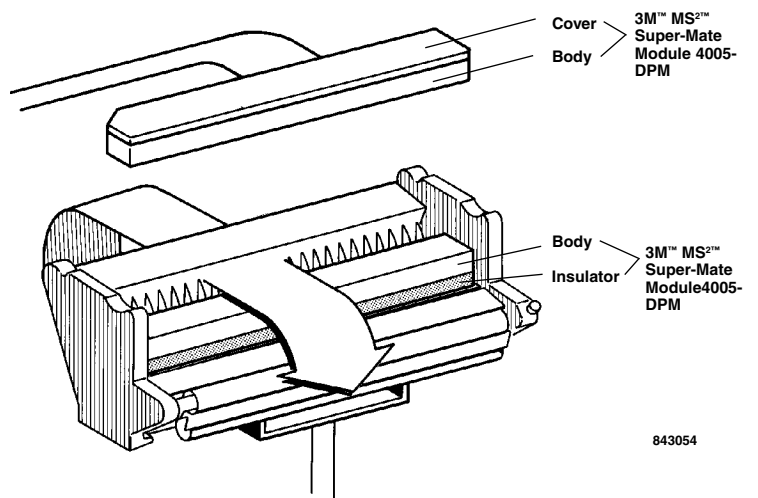

3M™ MS<sup>2</sup>™  
Super-Mate  
Module 4005-  
DPM

3M™ MS<sup>2</sup>™  
Super-Mate  
Module 4005-  
DPM

843054

# 3M™ MS<sup>2</sup>™ Modular Splicing System Instructions

5.5.4 Preterminated 3M MS<sup>2</sup> Super-Mate Module plugged to Preterminated 3M MS<sup>2</sup> Super-Mini Module is done by using a 3M MS<sup>2</sup> Hand Presser 4720-A.



3M™ MS<sup>2</sup>™ Hand Presser 4720-A

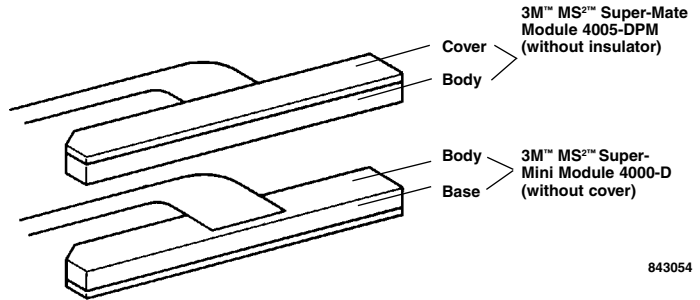

5.5.5 Preterminated Super-Mate Module plugged to Preterminated Super-Mate Module is done by using a 4720-A hand presser.

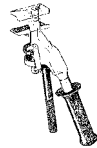

3M™ MS<sup>2</sup>™ Hand Presser 4720-A

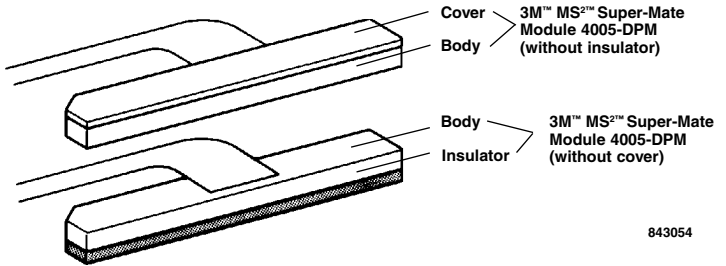

5.5.6 Three Super-Mate Modules (3-conductor splice) can be plugged together using a 4270-A hand presser. First, plug two Super-Mate modules with the 4270-A hand presser. Last, plug the third Super-Mate module with the 4270-A hand presser.

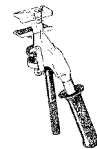

3M™ MS<sup>2</sup>™ Hand Presser 4720-A

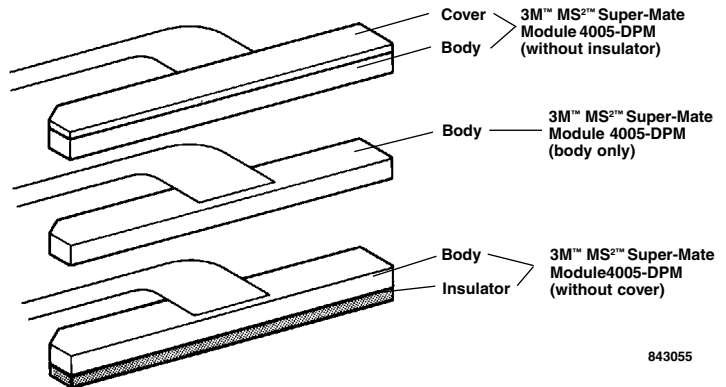

5.5.7 Preterminated Super-Mate Module Combination, Plugged to Preterminated Super-Mate or Super-Mini Module Combination.

Any module combination from two single modules to a total of seven modules may be plugged together using the 4270-A hand presser. Only a combination of up to three modules may be done in a splice head.

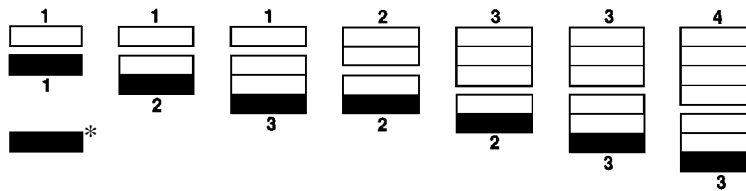

\* Can be either a 3M™ Super-Mini Module or a 3M™ Super-Mate Module with Insulator

842795

**Note:** If a Super-Mini module is used, it must always be on the bottom of the final configuration.

**Note:** It is recommended that only one module combination should be plugged together at a time.

## 6.0 Application

**Note:** *Splice modules so that equal number of modules will fall in each bank.*

### 6.1 Inline Splicing (2-Bank)

6.1.1 Splice opening must be that recommended for closure used, with a minimum of 17" (43.2 cm) for a 2-bank splice.

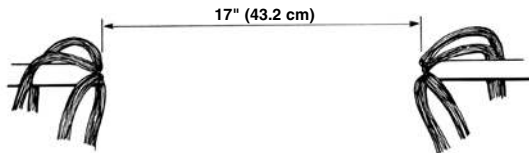

Free conductors length (each cable) = 1.5 X splice opening

893756

6.1.2 Attach rig using double heads. Center heads in opening.

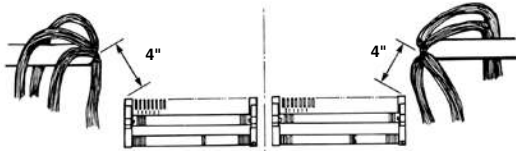

893756

**Note:** *Splice heads set 4" (10.2 cm) from butt of group being spliced and slightly higher.*

6.1.3 When splicing with 3M™ MS<sup>2</sup>™ Super-Mini Module, splice head adapter must be used.

Select back bottom 25-pair group from C.O. cable.

Lay pairs into module base on C.O. side of splice opening.

For easy group ID, place odd groups to left side, even groups to right side.

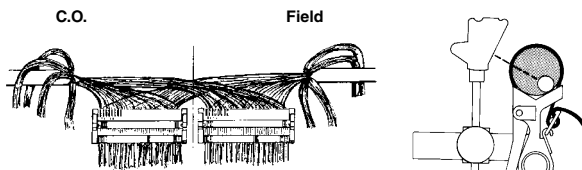

893756

75469

6.1.4 Select next back bottom 25-pair group from C.O. cable.

Lay pairs into module base on field side of splice opening.

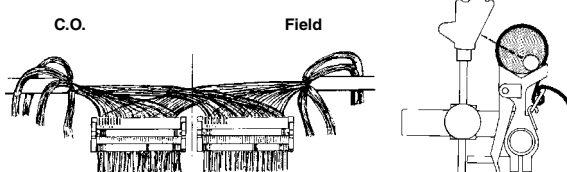

893756

75469

6.1.5 Place the check comb over the base and slide it to the left, only TIP (A) conductors should show. Slide the check comb to the right, only RING (B) conductors should show. Also check for two conductors in one channel, for vacant channels and for reversed pairs.

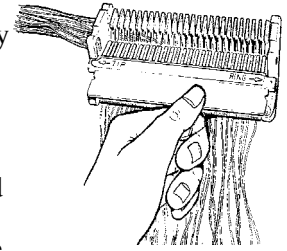

893745

6.1.6 Place body into leaf spring tracks of both splice heads with cut corner to left of rear splice heads.

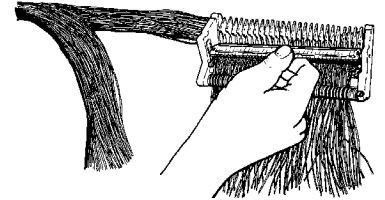

832600

6.1.7 Select matching 25-pair groups from field cable. Lay pairs into module bodies.

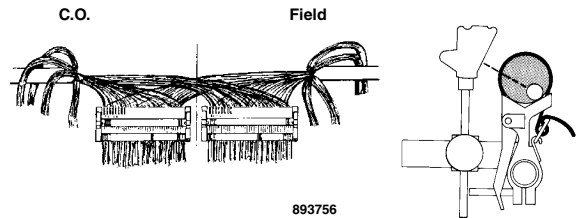

893756

75469

6.1.8 Check for correct placement of pairs.

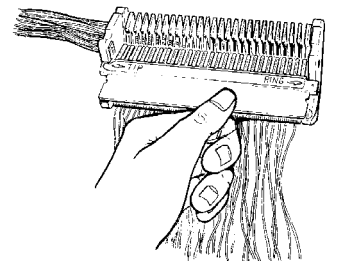

893745

6.1.9 Place covers and crimp. Repeat process for remaining 25-pair groups.

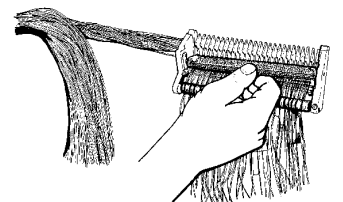

832601

6.1.10 Tie down splice bundle in center first, working any slack toward both cable butts.



75473

# 3M™ MS2™ Modular Splicing System Instructions

## 6.2 Inline Splicing (3-Bank)

6.2.1 Splice opening must be that recommended for closure used, with a minimum of 26" (66 cm) for a 3-bank splice.

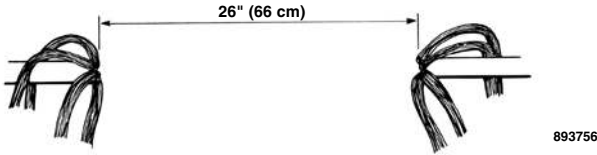

Free conductors length (each cable) = minimum splice opening plus 6" (152 mm)

6.2.2 Attach rig using single head. Splice first connector following wire handling procedure Inline Splicing (2-bank.)

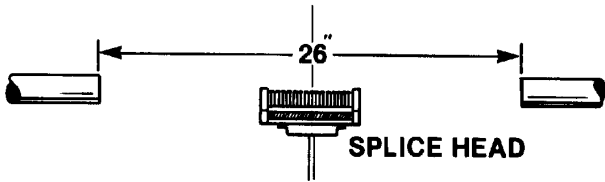

6.2.3 Adjust splice head for second connector. Splice per standard procedure (6.1).

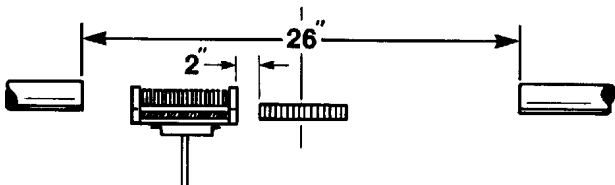

6.2.4 Adjust splice head for third connector.

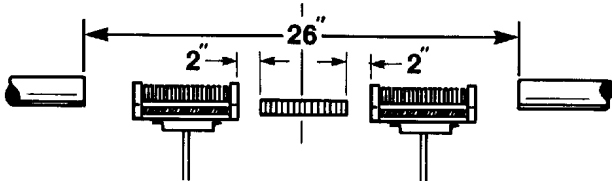

6.2.5 Complete splicing and bundling.



## 6.3 Inline Splicing (4-Bank)

6.3.1 Splice opening must be that recommended for closure used, with a minimum of 34" (86.4 cm) for a 4-bank splice.

*Note: This opening will require an extended support tube to attach to the cable butts; or support tube can be attached to a lower adjacent cable.*

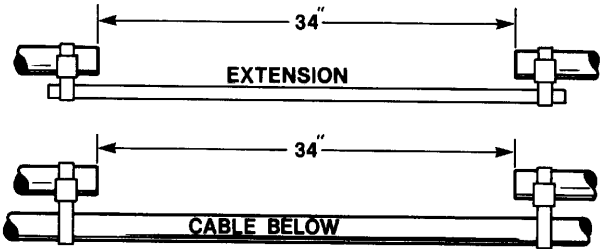

Free conductors length (each cable) = minimum splice opening plus 6" (152 mm)

6.3.2 Attach rig using double heads. Splice 100-pair in both heads in this position.

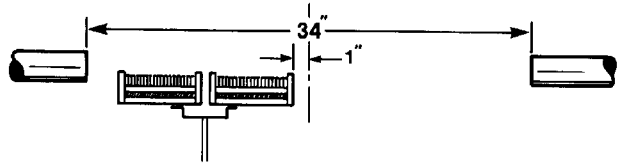

6.3.3 Adjust splice head for next 100-pair.

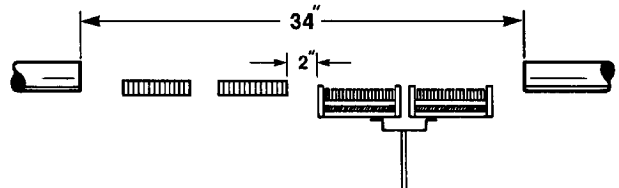

6.3.4 Adjust splice head for next 100-pair.

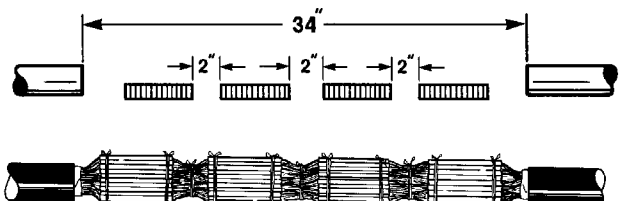

**6.4 Foldback Splicing (2-Bank)**

6.4.1 Splice opening must be that recommended for closure use.



Free conductors length (each cable) = 2 X splice opening plus 6" (152 mm)

6.4.2 Identify all binder groups. Starting with lower back groups, tightly tie matching groups together as close to cable butt as possible.

For easy group ID, **fold back odd number groups to left side and even number groups to the right.**

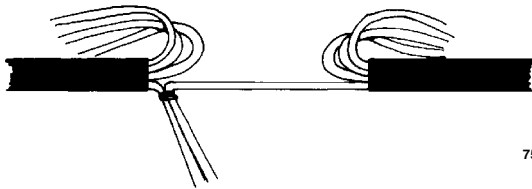

75449

6.4.3 Alternate tie points from side to side until all matching groups are tied.

*Note: Tie down core of splice with three ties or as per your company practice.*

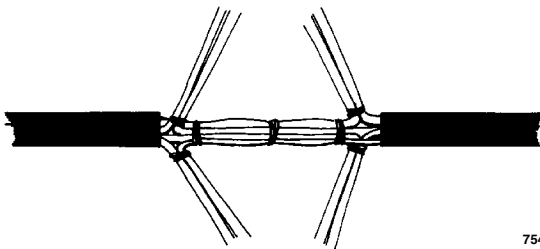

75449

6.4.4 Wrap core with polyethylene on PIC, muslin on pulp, or paper, per your company practice.

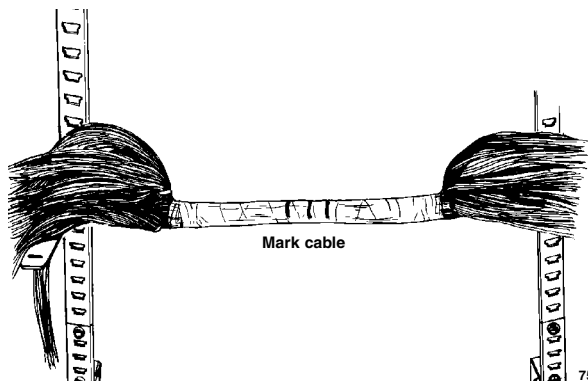

75450

6.4.5 Set up splicing rig.

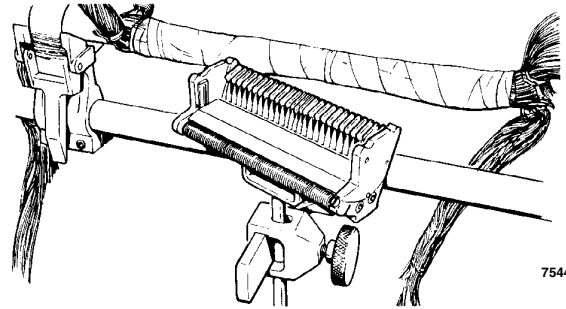

75442

6.4.6 Three measurements must be repeated for each binder group to be spliced.

**FIRST**

Align splicing head with marks to prevent modules from overlapping at center of splice or laying over tie points.

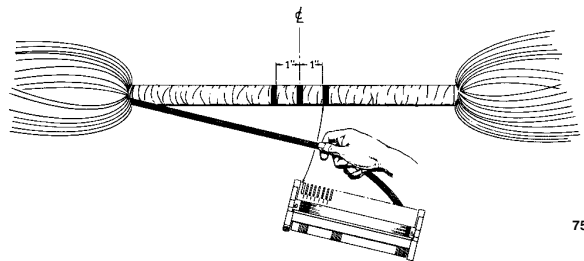

75451

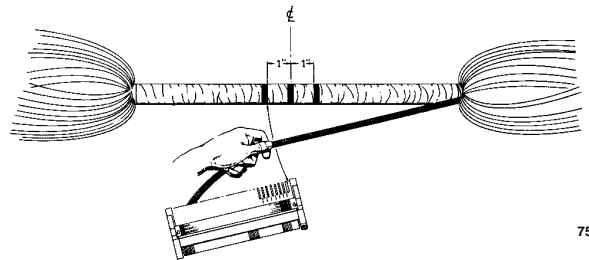

75452

**SECOND**

Rotate splicing head to assure that modules will lay parallel with core.

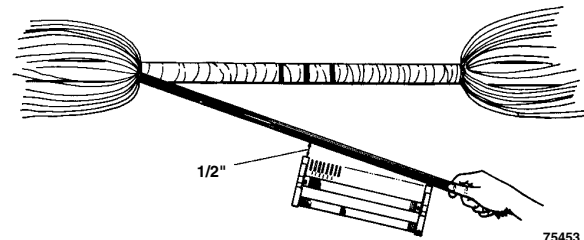

75453

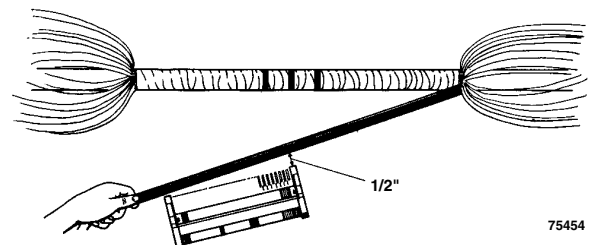

75454

# 3M™ MS<sup>2</sup>™ Modular Splicing System Instructions

## THIRD

Adjust height of splicing head to prevent conductors from lifting out of wire channels before module is crimped, and to assure easy removal of module from head after crimping.

Position head slightly higher than origin of group to be spliced so that wires are running at a slight angle up into splicing head.

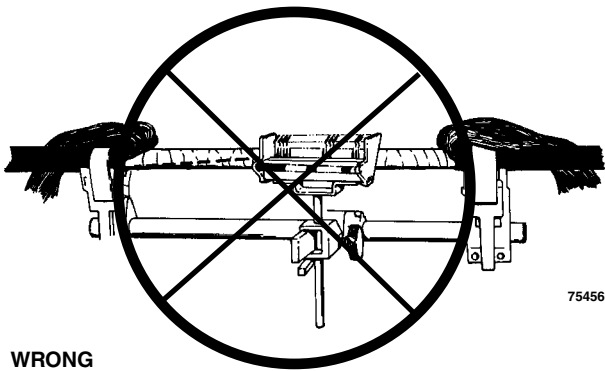
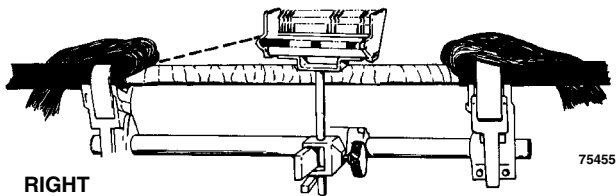

## 6.4.7 Bundle modules as they are being spliced.

Plan first module location.

Splice first 100-pair group at proper location. Mark each module with binder group number for identification. Use indelible marker on matte-finish of module cover.

Place tie around group near modules for ease of bundling and group identification.

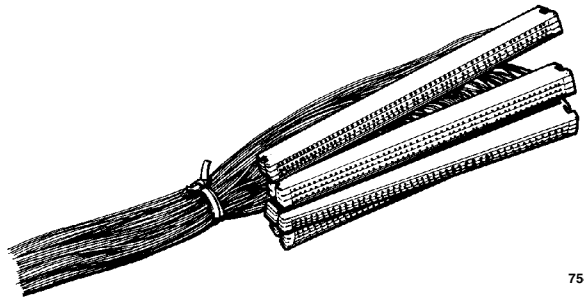

Lay group against core and bundle.

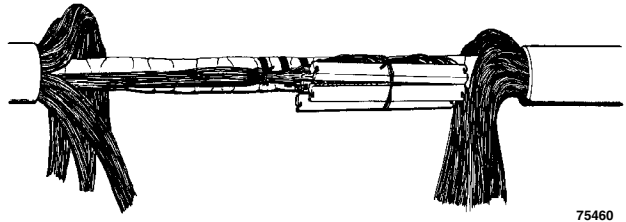

Move head to other side. Plan second group location.

Splice second group, identify and bundle to core. Repeat above, alternating left and right until splice is completed.

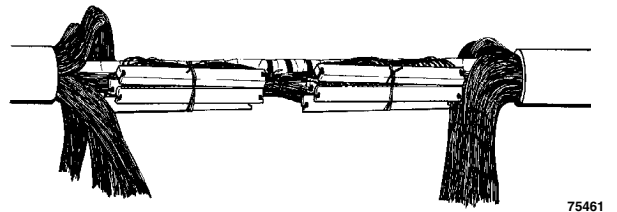

### 6.5 Foldback Splicing (2-Person)

Set up two splicing heads using LONG traverse bar.

Put long traverse bars on two traverse clamps. A 3/16" allen wrench is supplied.

*Note: For 2-person foldback splicing you will need two long traverse bars. (There may only be one to a rig.)*

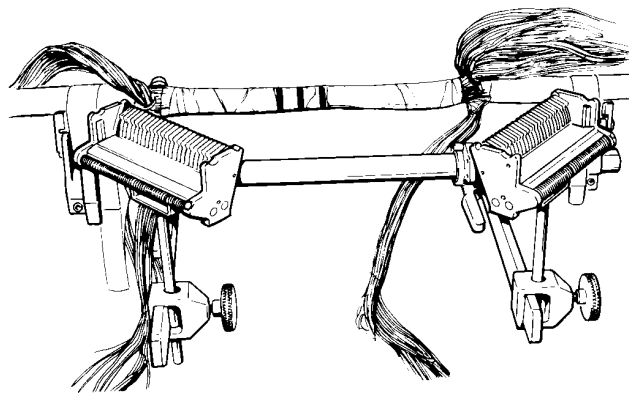
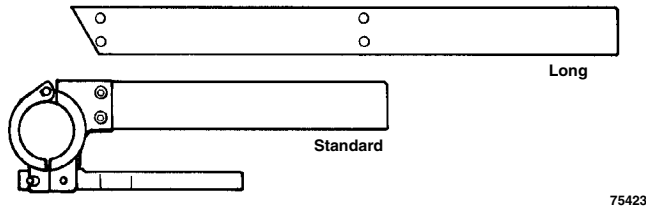

Each craftsperson will splice from one side, making the three basic measurements, described in Section 6.4.6. The modules spliced on the left will swing to the right of center and vice versa.

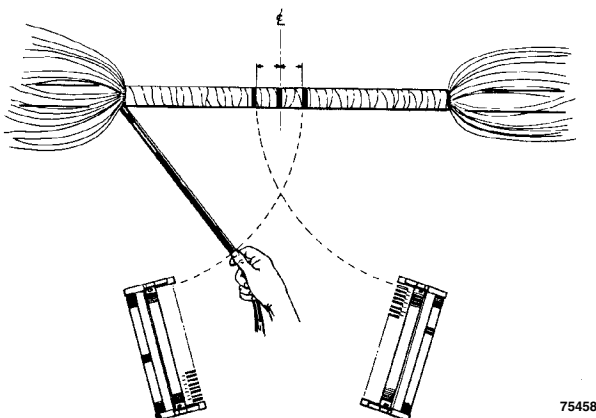

### 6.6 Foldback Vertical Splicing (2-Bank)

Mount support tube assembly to vertical cable.

Mount long traverse bar in **top holes** of traverse clamp with 3/16" allen wrench supplied.

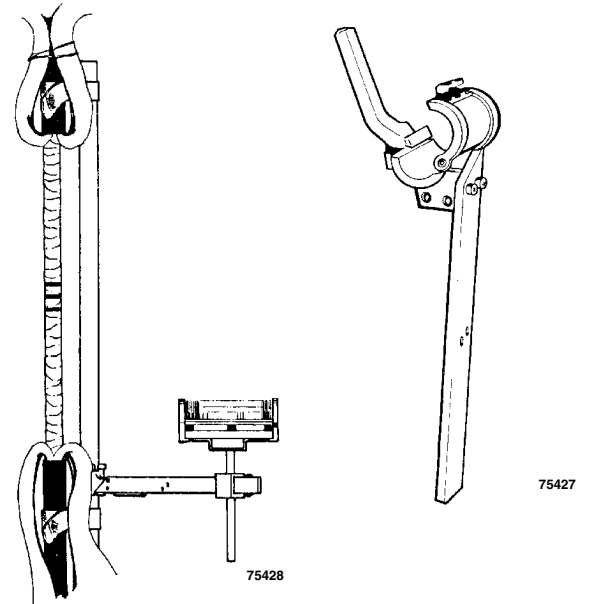

Attach traverse clamp assembly, head clamp and splicing head assembly onto support tube.

Measure an upper binder group so modules will fall below the lower 1" (25 mm) mark.

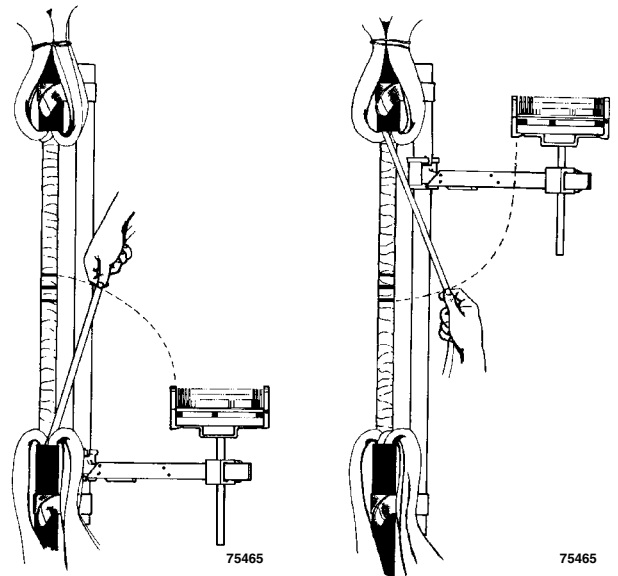

Measure a lower binder group so modules will fall below the upper 1" (25 mm) line.

# 3M™ MS2™ Modular Splicing System Instructions

## 6.7 Foldback Splicing (3-Bank)

6.7.1 Splice opening must be that recommended for closure use.

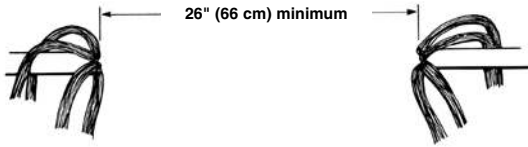

Free conductors length (each cable) = 2 X splice opening plus 6" (152 mm)

6.7.2 Identify all binder groups. Starting with lower back groups, tightly tie matching groups together as close to cable butt as possible.

For easy group ID, **fold back odd number groups to left side and even number groups to the right.**

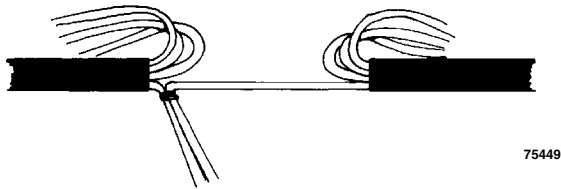

6.7.3 Alternate tie points from side to side until all matching groups are tied.

**Note:** Tie down core of splice with three ties or as per your company practice.

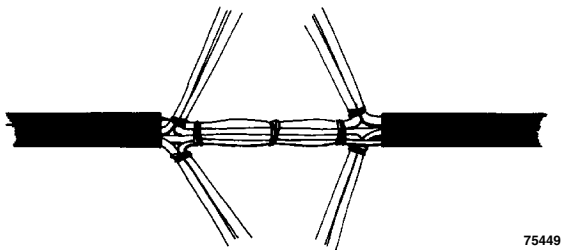

6.7.4 Mark center of splice and position head for first of 3-bank splice.

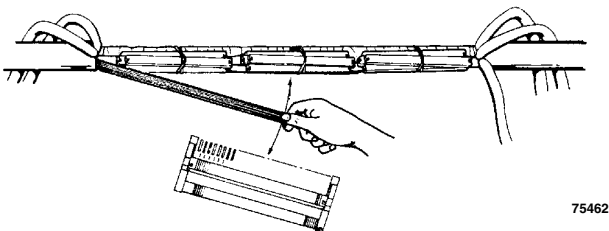

6.7.5 Splice first group, identify and bundle to the core.

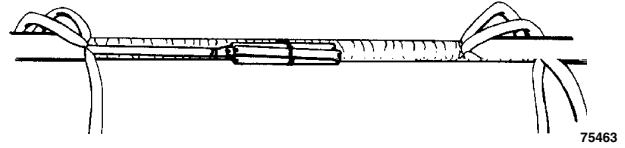

6.7.6 Position head for second group.

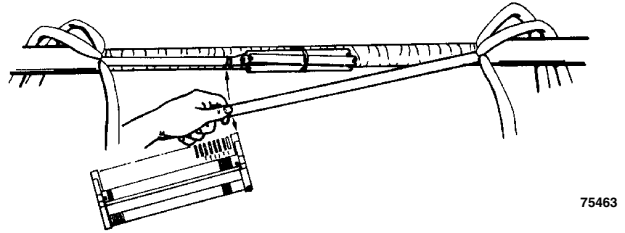

6.7.7 Splice second group, identify and bundle to the core.

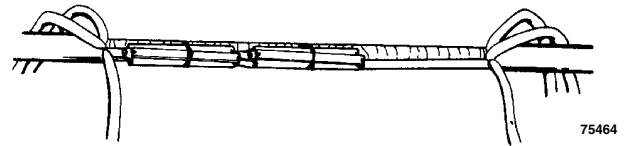

6.7.8 Splice third group.

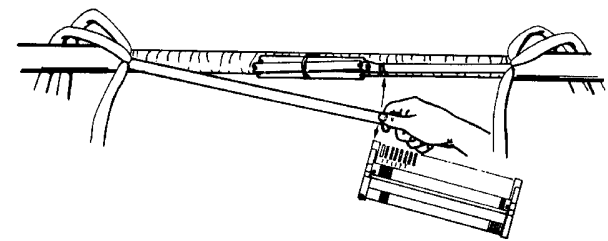

**Note:** When making 3-bank foldback splices, bundle while splicing. Splice a 100-pair group in one position, bundle to core; repeat procedure in another position and fit modules into vacant locations. Splice so that approximately an equal number of modules fall in each of the three positions.



**6.8 Unilength Splicing using 3M™ MS<sup>2</sup>™ Super-Mate Module 4005-DPM**

6.8.1 Attach unilength hook to splice head as shown. Hook can be attached on either side depending on which side of the splice opening the cable is entering from.

*Note: Refer to Section 8.6.2 for a definition of unilength splicing.*

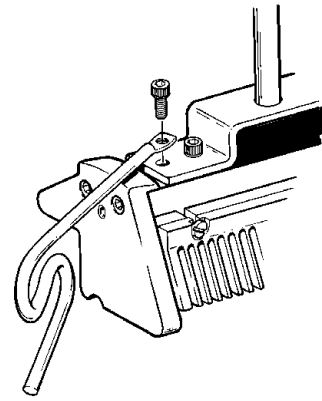

863364

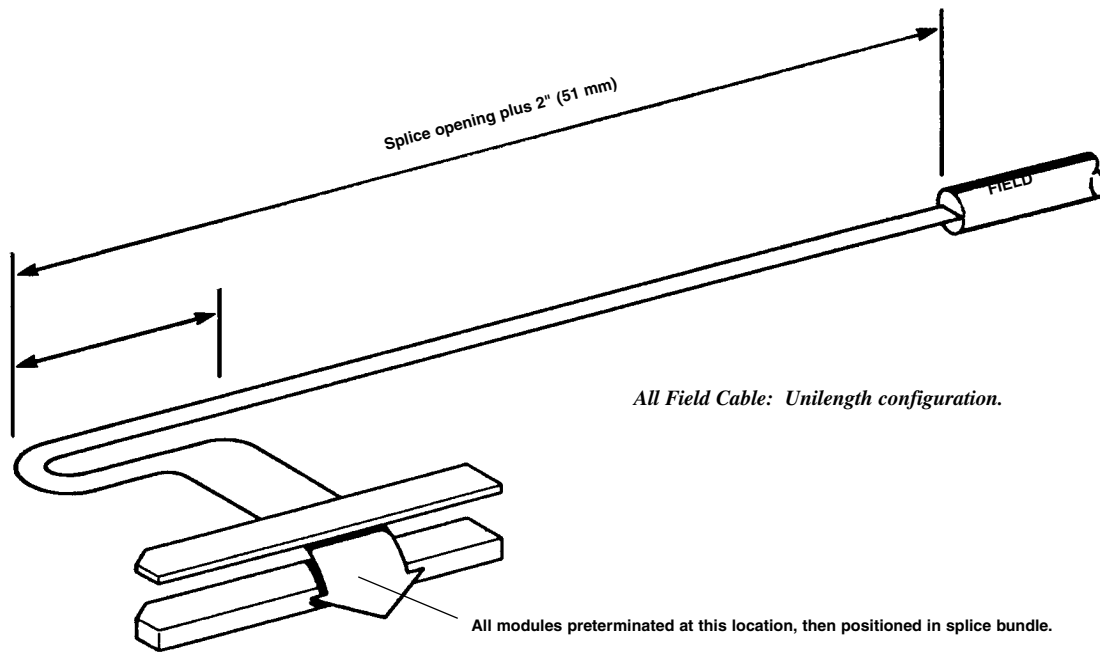

893736

6.8.2 Bring wire across the splice opening, then fold back 2" (51 mm) and splice.

*Note: Unilength measurement is always used when stubs are added to a splice and for any distribution cables in a modified foldback splice.*

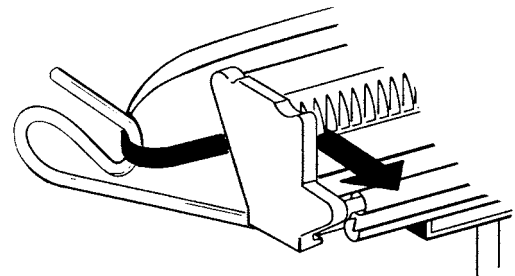

Configuration	Splice Openings	Unilength
2-bank	17" (43.2 cm) – 19" (48.3 cm)	19" (48.3 cm) – 21" (55.3 cm)
3-bank	27" (68.6 cm) minimum	29" (73.7 cm)
4-bank	36" (91.4 cm) minimum	38" (96.5 cm)

# 3M™ MS<sup>2</sup>™ Modular Splicing System Instructions

## 6.9 Bridge Splicing Using 3M™ MS<sup>2</sup>™ Super-Mate Module 4005-DPM to a 3M™ MS<sup>2</sup>™ Inline Super-Mini Splice 4000-D

893742

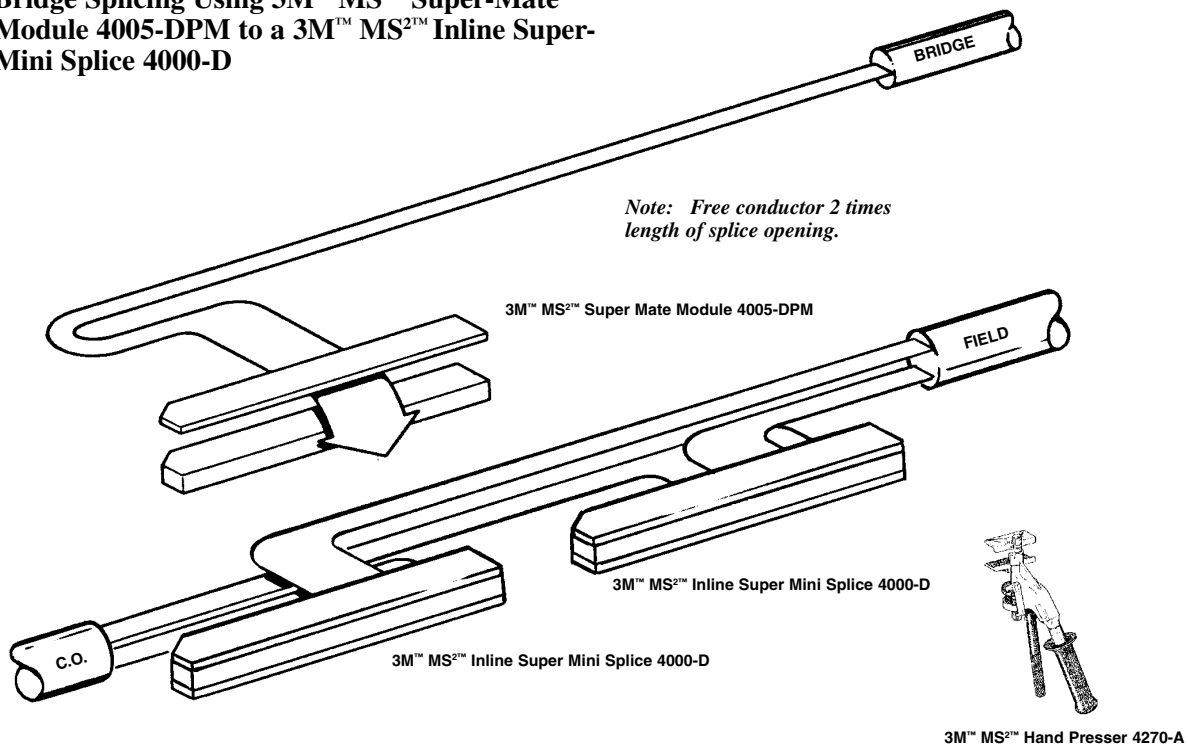

**Note:** A stripped splice head may be used with a crimper instead of hand tools.

### 6.9.1 PIC Cable

6.9.1.1 Preterminate module, then plug to corresponding groups.

### 6.9.2 Pulp Cable

6.9.2.1 Tag modules that receive stub count.

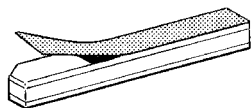

893742

6.9.2.2 Access with 3M™ MS<sup>2</sup>™ Test Probe 4047.

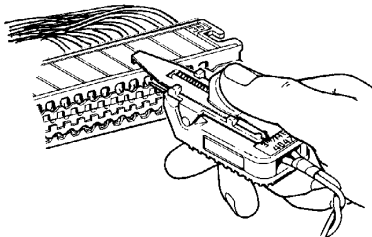

76586

6.9.2.3 Begin pretermination stub by removing tagging label from module in splice and placing it on the tape plate of splicing head. Immediately identify module from which tagging label was removed by marking the pair number on each end of the cover.

Pair numbers on each end of cover

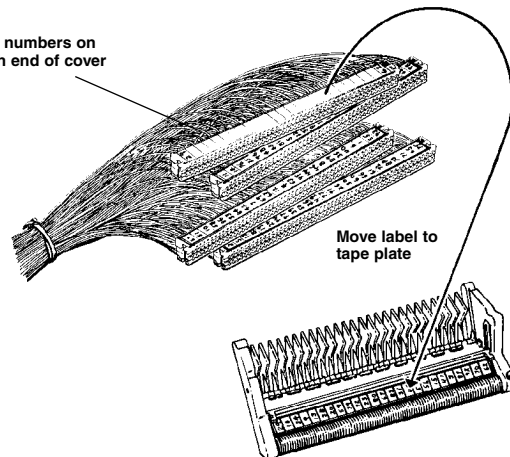

76579

6.9.2.4 Preterminate module, then plug to corresponding groups according to label.

### 6.10 Bridged Foldback Splicing

6.10.1 Tie binder groups from branch cable to corresponding groups in the splice so that slack exists for future transfers.

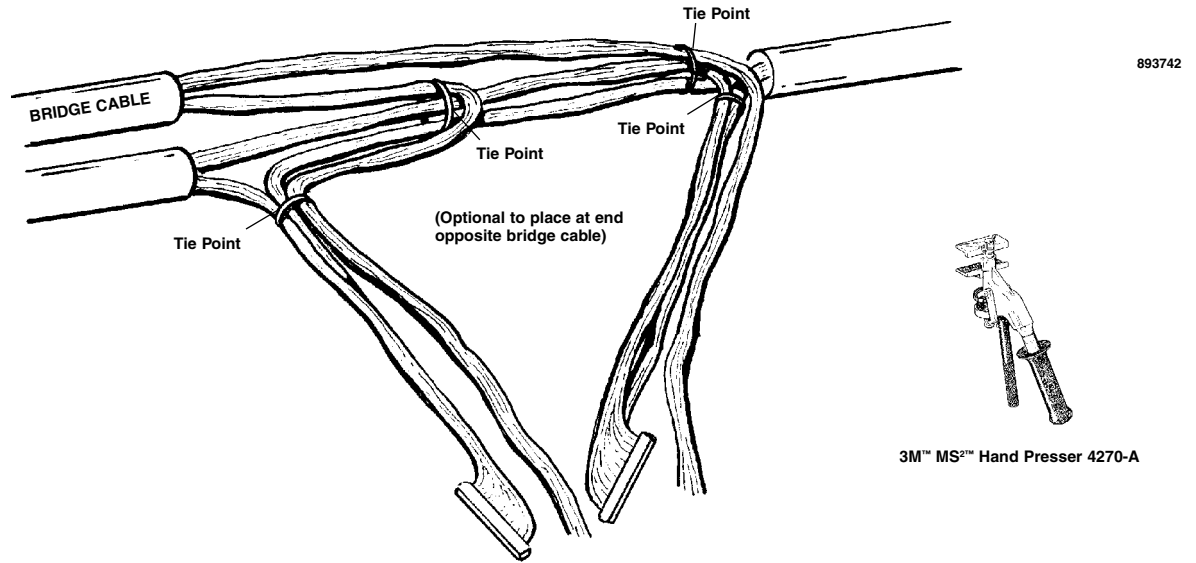

*Note:* A stripped splice head may be used with a crimper instead of hand tools.

#### 6.10.2 PIC Cable

6.10.2.1 Preterminate module, then plug to corresponding groups.

#### 6.10.3 Bridging PIC Stub Pulp Splice.

6.10.3.1 Tag modules that receive stub count using a 3M™ MS<sup>2</sup>™ Marking Pen 4039 on either the cover or a piece of tape.

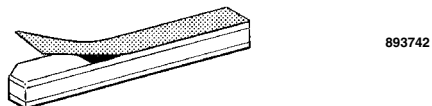

6.10.3.2 Access with a 3M™ MS<sup>2</sup>™ Test Probe 4047.

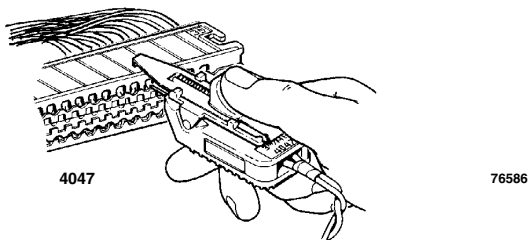

6.10.3.3 Begin pretermination stub by removing tagging label from module in splice and placing it on the tape plate of splicing head. Immediately identify module from which tagging label was removed by marking the pair number on each end of the cover.

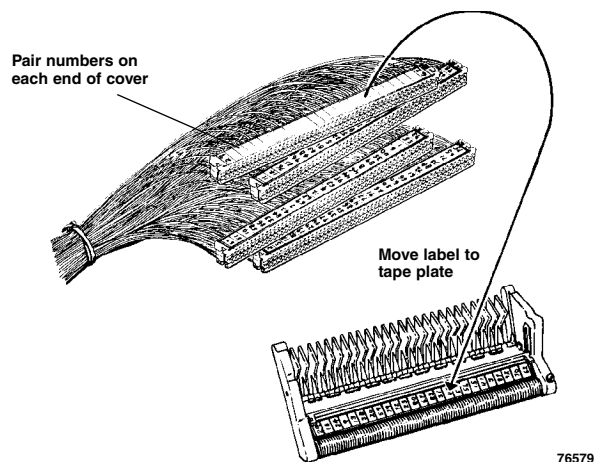

6.10.3.4 Preterminate module, then plug to corresponding groups according to label.

# 3M™ MS2™ Modular Splicing System Instructions

## 6.11 Half-Tapping Using the 3M™ MS2™ Half Tap Module 4008

The 3M™ MS2™ Splicing System can be used to half tap a run or through cable without cutting the conductors by using the 3M™ MS2™ Half Tap Module 4008. The base and body/bottom of the module are colored green and contain no cut-off blades. Through wires placed in the base will be electrically connected by the elements, but not cut off.

### SLACK

Minimum Requirements:

600 Pair or less ...8" (205 mm)

600-1500 Pair .....8" (205 mm) – 14" (355 mm)

The preferred splicing sequence is to start with the back bottom groups working up the back side.

**Note:** *Exception – Layered cable must be spliced starting with the center groups. This requires a larger opening to assemble the cable in 25-pair groups.*

When pulling slack, always allow binder groups to fall so that they will be on each side of the support tube when it is mounted. The cable twist will establish the most natural position.

It is preferred to place the tap cable on top of the cable to be removed.

Lay run (or through) conductors only in the module base with conductors to be removed out the front of module (spring side.) Use one splicing head.

6.11.1 Open cable sheath and expose conductors the length of the splice closure plus the amount of necessary slack.



893742

6.11.2 Pull cable slack until sheath ends are at recommended opening for splice closure.

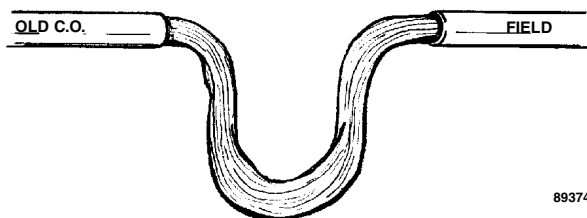

893742

6.11.3 Identify binder groups.

**Note:** *Layered cable must be counted and identified in 25-pair groups. Verify all spare pairs.*

6.11.4 Mount splicing rig. Use one splice head on short traverse bar.

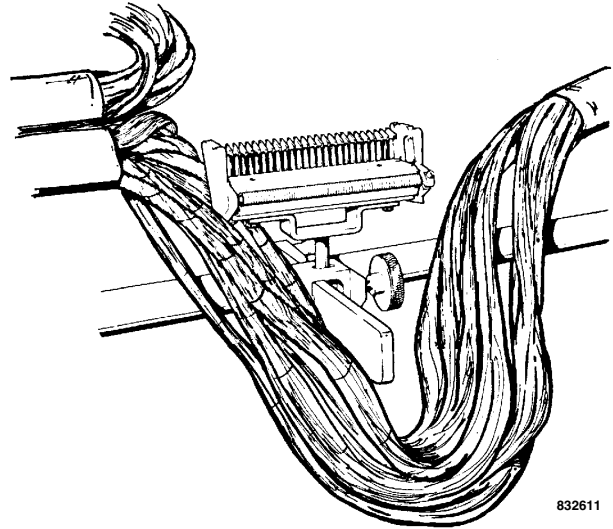

832611

Splice head should be positioned so that the 2-banks of modules will end up positioned 1" (25 mm) to the left of center of the opening, and 1" (25 mm) to the right of center. See Section 6.11.11.

6.11.5 Place adapter in splice head. Place module base onto adapter in splice head.

Always place run (or through) wires into base, making sure to pull slack toward cable to be removed.

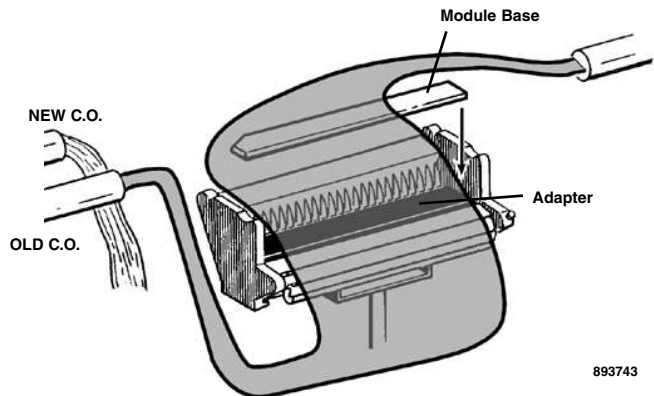

893743

6.11.6 Use check comb.

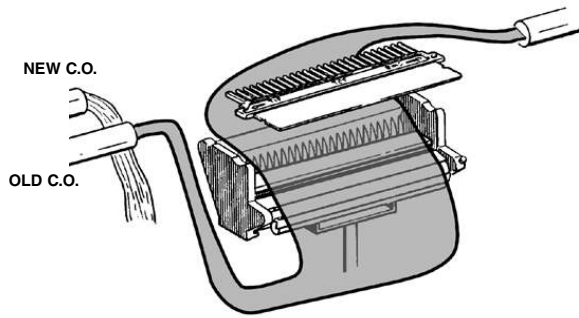

893743

6.11.7 Place 3M™ MS<sup>2</sup>™ Half Tap Module Body 4008, green side down.

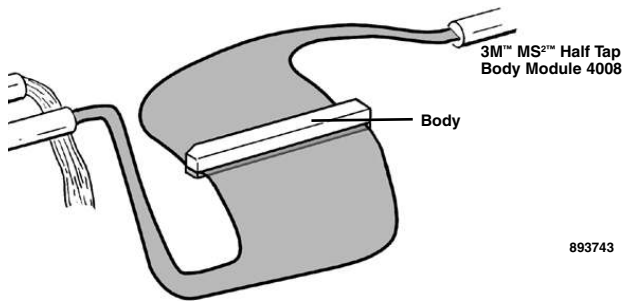

893743

6.11.8 Lay new wires in module body top.

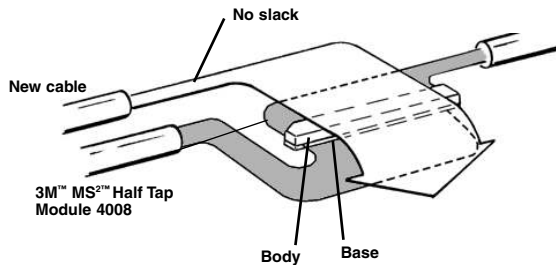

893743

6.11.9 Use check comb.

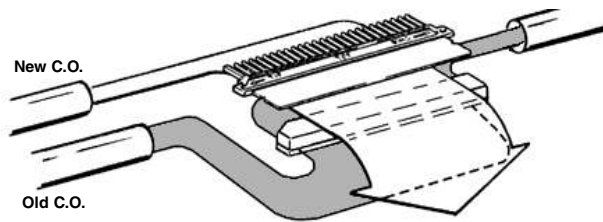

893743

6.11.10 Place cover and crimp.

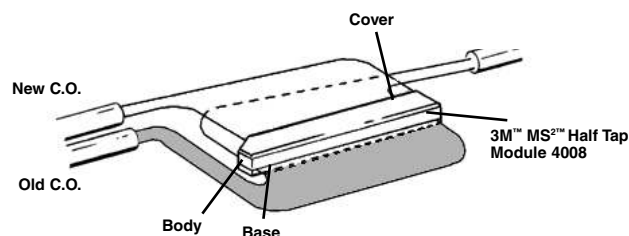

893743

6.11.11 Finish splicing 100-pair at this location and bundle. Keep slack toward leg to be removed. On larger pair count cables, gently fold excess slack behind the module while bundling to keep splice diameter and shape as small and as uniform as possible.

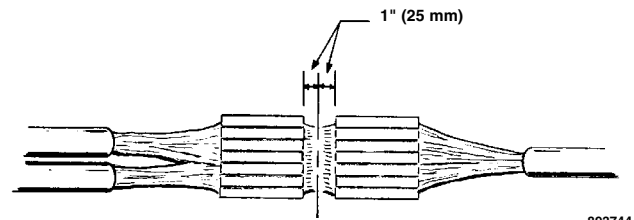

893744

Move head to opposite side. Set so that module will be 1" (25 mm) from center. Slack will still be pulled toward leg to be removed.

Splice 100-pair at this location. Bundle.

Move back to opposite side and do another 100-pair. Bundle. Repeat above, alternating left and right.

6.11.12 To remove half tapped cable, use a flush cut offset pair of pliers to allow one conductor to be cut at a time. Care should be taken not to short against adjacent cut conductors.

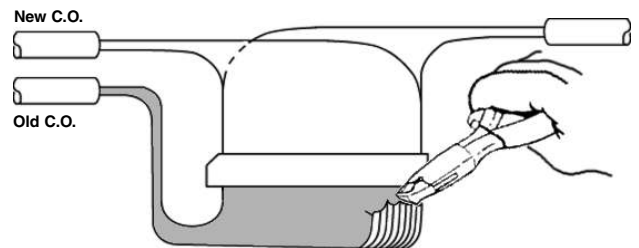

76588

Insulate all cable cut ends with 3M™ MS<sup>2</sup>™ Half Tap Cover 4078-C or a 3M™ MS<sup>2</sup>™ Sealant Box 4075-S, depending on application requirements.

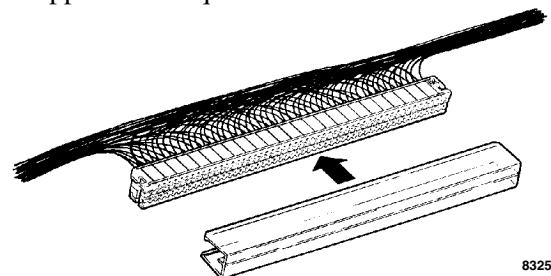

832570

**Note:** Carefully follow safety, health and environmental information given on product label or the MSDS sheet.

# 3M™ MS<sup>2</sup>™ Modular Splicing System Instructions

## 6.12 Half-Tapping Using 3M™ MS<sup>2</sup>™ Super-Mini Module 4000-D or 3M™ MS<sup>2</sup>™ Super-Mate Module 4005-DPM

6.12.1 Open existing tap cable (new cable). Provide free conductor length and slack according to standard 3M procedures for half-tapping.

Mount splicing rig with one splice head on cables.

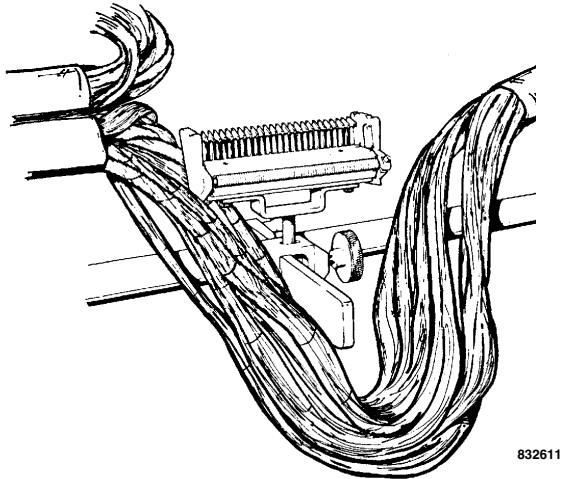

832611

6.12.2 Lay tap (new) conductors into base of a 4000 module in unilength configuration. Crimp module body using the back edge of the check comb as a temporary cover and remove cut conductors.

Lay field conductors into body top, but **DO NOT CRIMP**.

Place Super-Mate body onto Super-Mini body. Place corresponding through pair (old) and lay into matching wire channels of the Super-Mate module.

Place cover, crimp and remove.

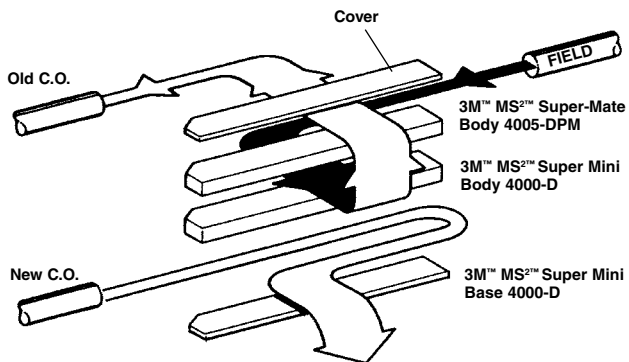

893863

6.12.3 When related work is complete and the removal of the old C.O. is needed; use the 3M™ MS<sup>2</sup>™ Separator Tool 4053-PM to separate the old cable that is in the module.

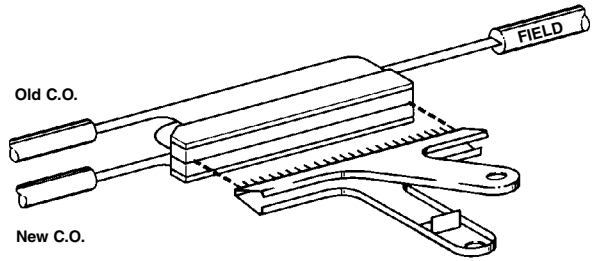

843063

6.12.4 Crimp a new cover onto the module and place a red insulator on the module.

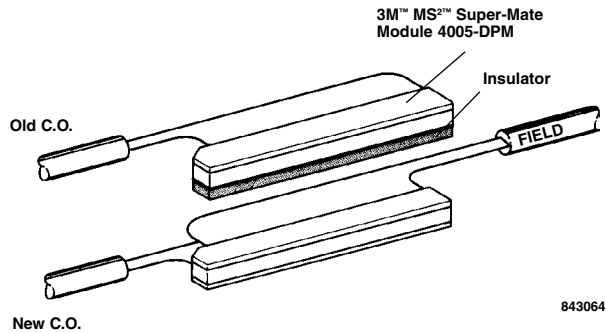

843064

**6.13 Half-Tapping Using 3M™ MS<sup>2</sup>™ Super-Mate Module 4005-DPM**

An alternative method of half-tapping existing cables, using only 4005 Series Super-Mate pluggable modules, is available where the advantages of a completely pluggable half-tap splice are desired.

*Note: When half-tapping using all Super-Mate modules, the wire guide and wire separator should be raised to their maximum height by loosening the 3 screws at the back of the splice head and raising both the wire guide and separator, and re-tightening the screws.*

6.13.1 Open existing tap cable (new cable.) Provide free conductor length and slack according to standard MS<sup>2</sup> procedure for half-tapping.

Mount splice rig with one splice head on cables.

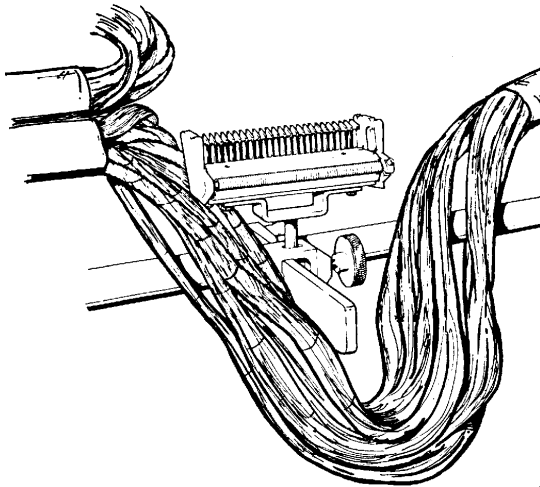

832611

6.13.2 Lay tap (new) conductors into a module in the unilength configuration. Place a second module into the splice head and crimp, using the back edge of the check comb as a temporary cover and remove cut conductors.

Lay the field conductors into the second module, but **DO NOT CRIMP**.

Place a third Super-Mate module into the splice head. Lay corresponding pairs (old) into the matching wire channels of the third module.

Place cover, crimp and remove conductors.

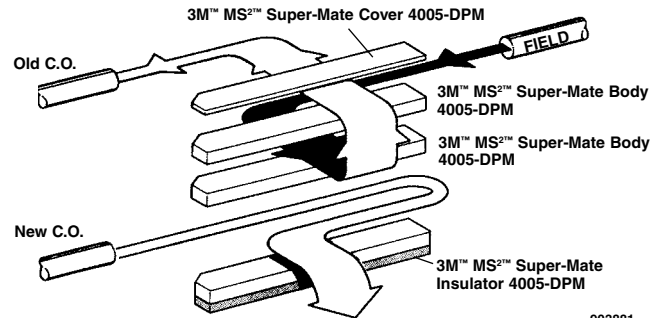

903881

**Optional Method:**

New C.O. cable may be preterminated in the unilength configuration. Old C.O. and field cable may be handled as described in Section 6.14 Slack Removal, using 4005-DPM Super-Mate modules.

6.13.3 When related work is complete and the removal of the old C.O. is needed; use the 3M™ MS<sup>2</sup>™ Separator Tool 4053-PM to separate the old cable that is the **top** module.

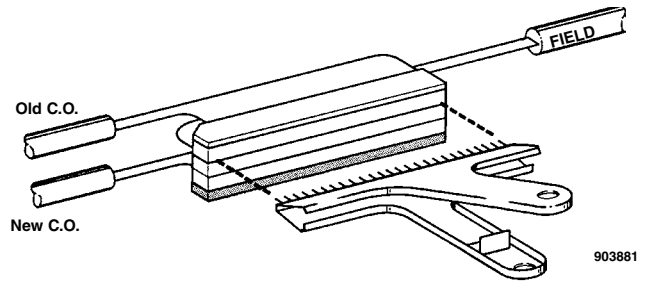

903881

6.13.4 Crimp a new cover onto the splice and place a red module insulator on the old C.O. module termination.

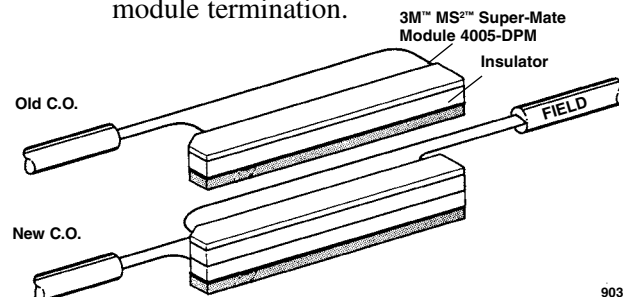

903881

6.14 Slack Removal

*Note: In 3M™ MS<sup>2</sup>™ Modules 4000 Series, connection is made in "U" contact before wire is cut.*

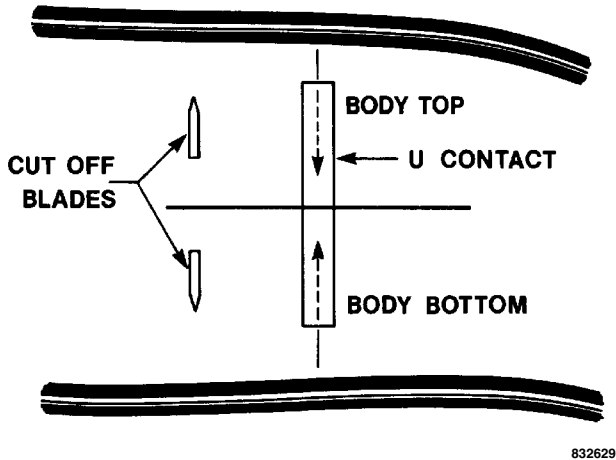

6.14.1 Remove sufficient sheath so that once slack is removed, the splice opening remaining will accommodate closure to be used.  
Set up splice rig with single head and adapter.

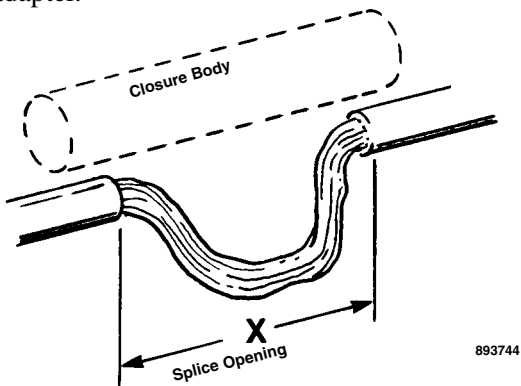

6.14.2 Place 4000 base in splice head and place a 25-pair group in base. Let slack loop fall down in front and below retainer springs.

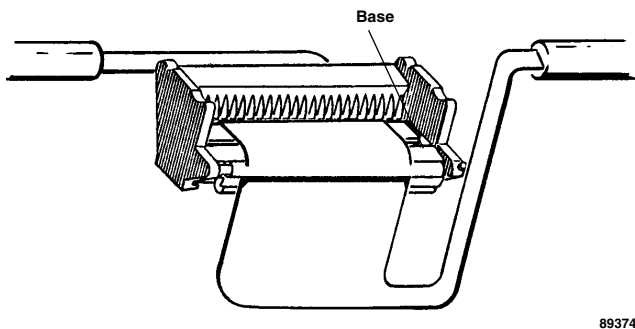

6.14.3 Place body in head.

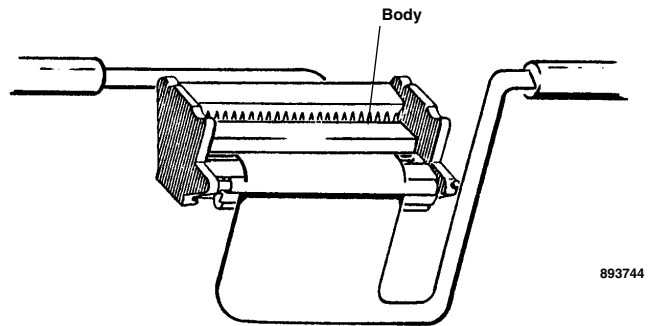

6.14.4 Take conductors from other side of splice opening and place in body top.

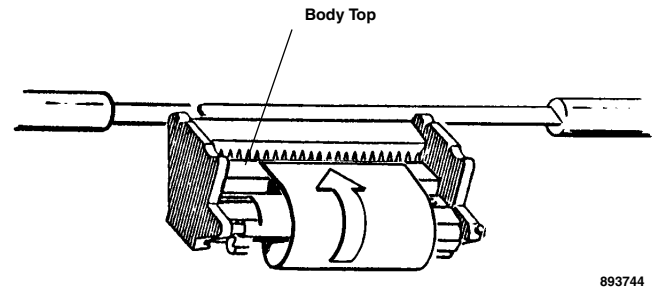

6.14.5 Fill body/top completely, add cover and crimp. Slack can now be removed.

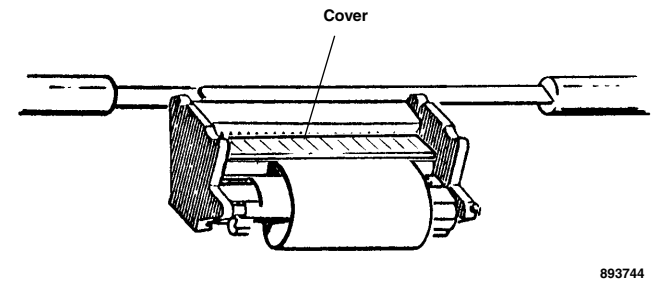



## 7.0 Maintenance

### 7.1 Module Reentry

7.1.1 Insert the blade side of a pair of snips under the cut corner area of the base or cover. (There are no latches in this immediate area.)

A 3M™ MS<sup>2</sup>™ Cover Removal Tool 4053 may also be used.

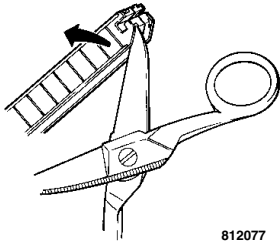

812077

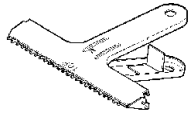

74011

7.1.2 Peel cover or base away.

**Note:** Do not reuse covers or bases. Covers or bases can be placed on the module using the following tools:

3M™ MS<sup>2</sup>™ Crimp Tool E-9BM

3M™ MS<sup>2</sup>™ Splice Head Holder 4041-SH

3M™ MS<sup>2</sup>™ Air/Hydraulic Crimping Unit 4030

3M™ MS<sup>2</sup>™ Hand/Hydraulic Crimping Unit 4031

3M™ MS<sup>2</sup>™ Hand Crimper 4036-25

3M™ MS<sup>2</sup>™ Hand Presser 4270-A

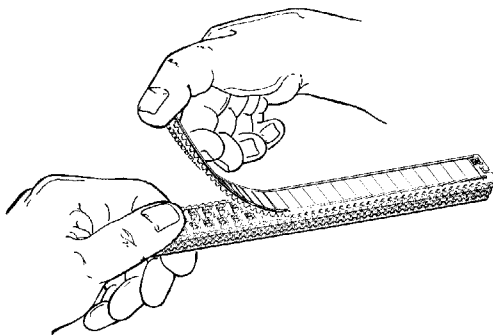

781194

### 7.2 Wire Insertion

The 3M™ MS<sup>2</sup>™ Wire Insertion and Cut Off Tool 4051 is used to insert wires into the "U" contact and to cut off excess wire in Super-Mini modules when conductor or Super-Mate rearrangements are made inside the module.

7.2.1 Pull wire across top of "U" contact and cut off blade.

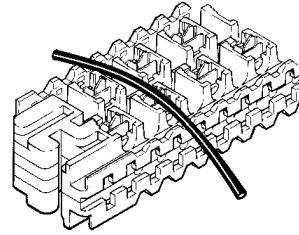

781178

7.2.2 Align tool with "U" contact and wire. The slot is aligned with the "U" contact and the groove with the wire.

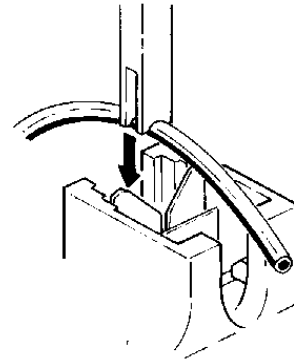

781186

7.2.3 Push **straight down** forcing the conductor into the "U" contact. **DO NOT ROCK TOOL BACK AND FORTH.**

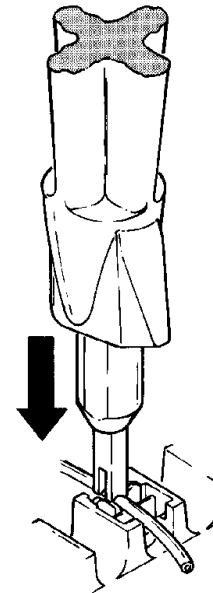

781186

7.2.4 To cut off wire, align slot with cut off blade and groove with wire. Push **straight down**. Remove excess wire from module. **DO NOT ROCK TOOL BACK AND FORTH.**

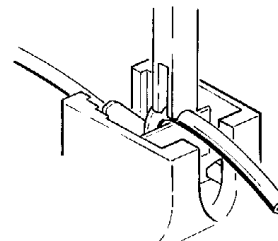

781186

# 3M™ MS<sup>2</sup>™ Modular Splicing System Instructions

## 7.3 Splice Conversion to 3M™ MS<sup>2</sup>™ Modules 4005-DPM

### When:

- 50% or more of the conductors will be rearranged.
- Deteriorated splices.
- Discrete connector splices.
- Splices already partially converted.

### Slack Requirements:

- Inline ..... 6" (152.4 mm min.)
- Straight Through ..... 6" (152.4 mm min.)
- Foldback ..... Slack already built in.

**Note:** *This operation requires using the rear spring holder and the front wire retainer spring.*

### Prepare Splice Head:

Place spring on holder by sliding onto the flat plate of the rear spring holder.

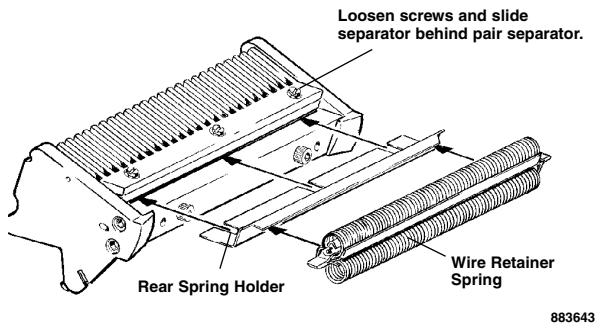

### 7.3.1 Foldback Conversion: (Maintaining Foldback Configuration)

- 7.3.1.1 Place the splice head into the approximate position of the original connectors when they were spliced. Remove front wire retainer spring.
- 7.3.1.2 Straighten the wires at the rear of the existing (old) connectors.
- 7.3.1.3 Place DPM module into splice head and secure existing connector to tape panel.

7.3.1.4 Fan C.O. wires into body and place excess wire into rear spring.

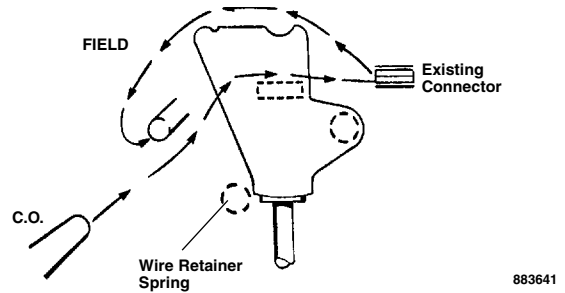

7.3.1.5 Add second body.

7.3.1.6 Fan field wires into second body and place excess wire into wire retainer spring, add cover and crimp.

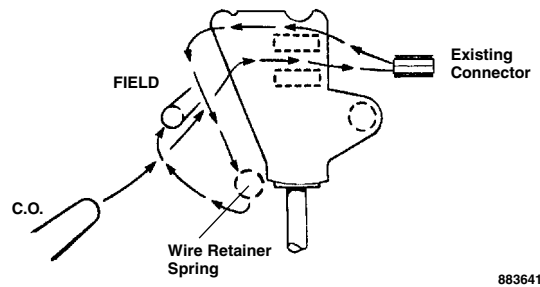

**Note:** *Care must be taken to match the same pair of conductors in the body/top wire channels that appear in the body/bottom channels. Pair one on top must match pair one on bottom.*

**Note:** *It may be necessary to adjust the tie point to maintain a neat splice.*

### 7.3.2 Foldback Conversion: (To Inline)

Cut the tie points, expose the core and place available slack wire length in splice head.

### 7.3.3 Inline – PIC:

A minimum of 6" (152.4 mm) of slack is required to convert an Inline PIC splice. Follow steps used in the Foldback Conversion procedure. (section 7.3.1)

**7.3.4 Straight Through Conversion:  
(6" Slack Required)**

7.3.4.1 Separate color groups to be spliced, i.e., white, red, black, etc., and begin with the primary colors, i.e. white/blue, white/orange, white/green, etc., and lay wires into splice head in consecutive order in the first DPM module.

*Note: Turn splice head to open the rear spring angle and to allow entry of conductors into the rear wire retainer spring.*

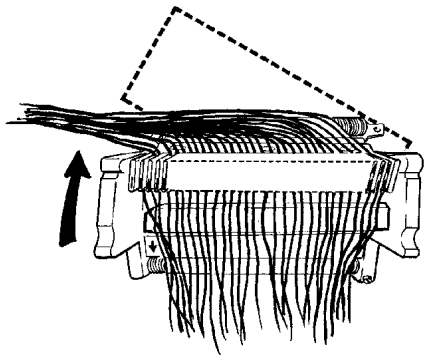

883641

7.3.4.2 Lay in second DPM body and lightly tap the body on each end, set latches and reduce movement.

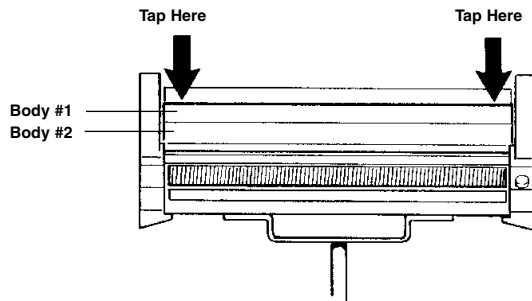

883634

7.3.4.3 Remove wires a pair at a time from the spring, starting from one end of splice head working to the other end. Wires will be placed over on top body and placed in rear spring.

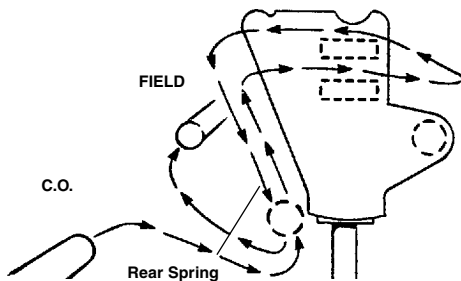

883641

Place cover and crimp.

**7.3.5 Straight Through Conversion (No Slack)  
Using Two 3M™ MS<sup>2</sup>™ Splice Heads 4041:**

7.3.5.1 Build a piece out jumper using the DPM modules. Use sufficient slack to allow mobility within the splice.

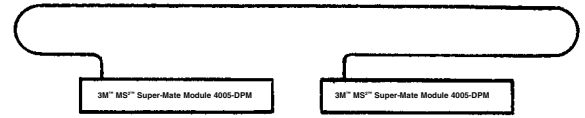

To reduce splice bundle size, build piece out jumpers using 3M™ MS<sup>2</sup>™ Inline 4000-D Super-Mini and 3M™ MS<sup>2</sup>™ Super-Mate Modules 4005-DPM. Alternate Super-Mini and Super-Mate 4005-DPM modules between right and left banks.

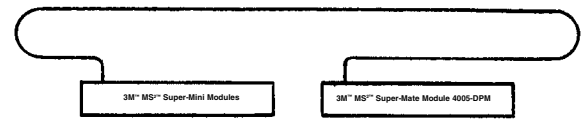

88634

7.3.5.2 Center double head set-up into splice opening.

7.3.5.3 Place appropriate piece out of jumper into each splice head.

7.3.5.4 Place second body into each head and crimp.

7.3.5.5 Verify group to be cut.

7.3.5.6 Cut first straight through cable pair at pair 17 (y/o) of left hand splice head. After pair has been cut, place left cut end in first wire way of body/top (bl/w) of left splice head; place right cut end in first wire way (bl/w) of right splice head.

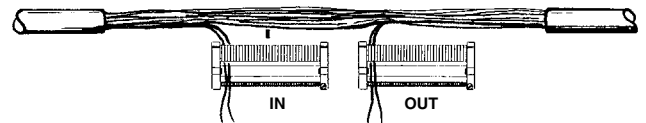

883863

*Note: If pair is working, use bridge clips.*

# 3M™ MS<sup>2</sup>™ Modular Splicing System Instructions

7.3.5.7 Insert conductors in contacts body/top using a 3M™ MS<sup>2</sup>™ Wire Insertion and Cut Off Tool 4051.

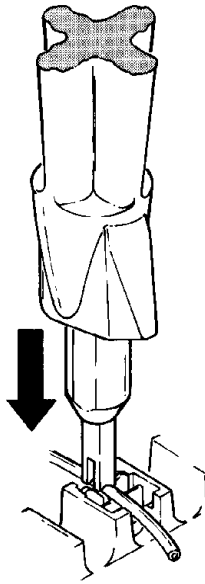

781186

7.3.5.8 Cut second straight through cable pair at pair 18 (y/gr) of left hand splice and insert in pair number two (o/w) locations on each splice head. Continue cutting each successive pair in the 25-pair group, moving over one pair each time, until both module body/tops are filled. The last of the 25-pair group will be made at pair number seven (t/o) of the right hand splice head.

7.3.5.9 Add cover and crimp.

## 7.3.6 Pulp Splices – Random Foldback

To convert a random pulp splice into DPM modules, the following requirements must be observed.

**Note:** *Ideally, an extended sheath opening should be made, however, if this is not possible observe the following steps.*

7.3.6.1 The splice must be a foldback configuration with at least 27" (68.6 cm) of slack at its longest section.

7.3.6.2 The cable count to be converted must be tagged.

7.3.6.3 The new DPM module must be placed in the splice at the point between the cable butt and the first cable tie point.

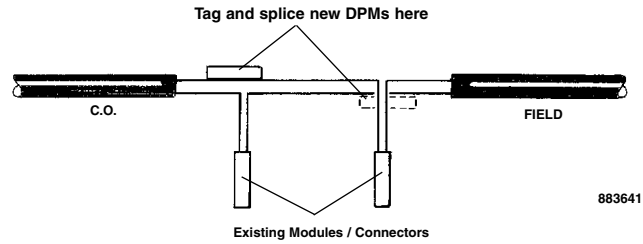

7.3.6.4 Remove all tie points.

7.3.6.5 Mount single splicing head in a position 2" (52 mm) from cable butt. Place DPM module in head.

7.3.6.6 As pairs are identified, place in numerical order in module, i.e., cable pair #6 into module position #6 and so on.

7.3.6.7 Add second DPM body, fold pair over itself and place pair into rear spring.

7.3.6.8 After the first 25-pair are completed, crimp the DPM module.

7.3.6.9 Continue on until the entire cable count to be converted are in DPM modules in numerical order.

7.3.6.10 Once sections have been tested and verified per your company practice and the old section ready to cut, remove old section from the splice using the 3M™ MS<sup>2</sup>™ Separation Tool 4053-PM.

## 8.0 Engineering

### 8.1 Job Planning

A major consideration while planning is the maximum protection of the feeder plant network. Restriction of reentry into the main feeder splice must be emphasized.

### 8.2 Moisture Protection

All 3M™ MS<sup>2</sup>™ Modules are available in either dry versions for pressurized, vault or inside splice applications; encapsulated versions for moisture resistance in free-breathing aerial splice closures; or in a dry version with sealant box for maximum moisture protection in non-pressurized PIC splicing applications.

### 8.3 Fire Retardancy

All dry MS<sup>2</sup> module types are available in flame retardant versions for vault and inside splice applications. All materials that comprise the fire retardant MS<sup>2</sup> modules meet UL Standard 94-VO requirements and possess an Oxygen Index of 28 or greater per ASTM Test Method D2863.

### 8.4 Rebuilding Existing Splices

#### 8.4.1 Reasons to Rebuild:

- 50% or more of the conductors require rearrangement
- Deteriorated splices
- Discrete connector splices
- Splices already partially converted

#### 8.4.2 Disadvantages of Rebuilding:

- Costly
- Time consuming

#### 8.4.3 Advantages of Rebuilding:

- Ability to plug and unplug
- Improve life and usability of splice
- Ease of maintenance

#### 8.4.4 Special Considerations:

- Inline splices require 10" to 12" (254 to 305 mm) of slack for conversion
- Without required slack, piecing out is necessary
- Piecing out requires additional modules in splice, resulting in reduced splice capacity in splice closure
- Use proper symbols to fully identify all splice points

**Note:** *If Rear Spring Holder is used, a minimum of 6" (152 mm) of slack is required.*

### 8.5 Rebuild Coding

Engineering, by chart computation, will determine how many module banks will be required to complete a specific splice. Splice bank configurations and splice types are listed on the work print at each splice location according to a simple coding system.

This system tells the splicer what connectors are required and what configuration the splice is to be built in. It also indicates to the engineer what flexibility the splice has for the future. This coding is added to the cable records for future reference.

- S – Straight
- F – Facility
- J – Junction
- L – Load
- X – Non-standard
- RN – Rebuild needed
- RC – Rebuild completed

**Note:** *Code always starts with a number representing the number of banks in a splice. One of three configurations will be used.*

Configuration	Splice Opening	Unilength
2-Bank	17"–19" (43.2 cm–48.3 cm)	19"–21" (48.3 cm - 55.3 cm)
3-Bank	27" (68.6 cm) min	29" (73.7 cm) min
4-Bank	36" (91.4 cm) min	38" (96.5 cm) min

Example 1:

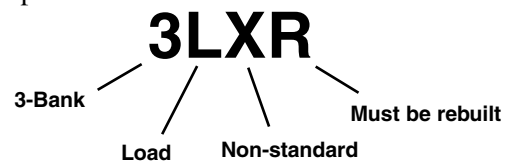

Example 2:

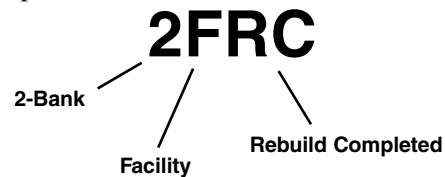

# 3M™ MS2™ Modular Splicing System Instructions

## 8.6 Splice Planning

8.6.1 Splice sizing is necessary to determine the proper sheath opening and the proper splice closure size. Too many cable conductors spliced in a closure without adequate splice banks may stress wires with module movement. Reentry and churning conductors without proper planning, leads to rapid deterioration of cables at their weakest point – the splice.

Calculate splice and closure size using the following factors:

- Cable pair count
- Wire gauge
- Connector type
- Splicing method

### 8.6.2 Unilength Splicing Method

Wire is brought across the splice opening plus 2" (51 mm.) Wire bundle must be folded back and then spliced into the module.



Unilength measurement is always used when stubs are added to a splice and for any distribution cables.

### 8.6.3 Inline Splicing Method

Wire is placed in a straight across arrangement. This method is not designed to be rearranged and should have minimum handling.

### 8.6.4 Fold Back Splicing Method

Conductors are folded into the splice to provide slack in the conductors for maintenance, rearrangement or transfer of conductors.

## 8.6.5 Splice Data

Data in the following tables was obtained from splices prepared according to the instructions in this practice. When the Bundle O.D. is close to Splice Case or Sleeve I.D., the craftsperson must use extra care not to exceed the maximum O.D. If sealant boxes are used, increase values approximately 25%.

### 8.6.5.1 2-Bank Inline Splice Data (Super-Mini)

Pair Count	AWG		Recommended Splice Opening		Inline Splice Dia.	
		mm	in.	mm.	in.	mm
400	26	.4	17	432	2.6	66
	24	.5			2.9	74
	22	.6			3.2	81
600	26	.4	17	432	3.1	79
	24	.5			3.5	89
	22	.6			4.6	117
900	26	.4	17	432	3.8	94
	24	.5			4.2	107
	22	.6			5.6	142
1100	26	.6	19	483	4.0	102
1200	26	.4	17	432	4.2	107
	24	.5			4.7	117
1500	26	.4	19	483	4.9	124
	24	.5			5.5	140
1800	26	.4	17	432	5.4	137
	24	.5			6.0	152
2100	26	.4	17	432	5.8	147
	24	.5			6.5	165
2400	26	.4	19	483	6.2	157
2700	26	.4			6.6	168
3000	26	.4	19	483	7.0	178
3600	26	.4			7.7	196

### 8.6.5.2 2-Bank Fold Back Splice Data (Super-Mini)

Pair Count	AWG		Recommended Splice Opening		Inline Splice Dia.	
		mm	in.	mm.	in.	mm
400	26	.4	17	432	2.8	71
	24	.5			3.3	89
	22	.6			4.0	102
600	26	.4	17	432	3.2	81
	24	.5			3.9	99
	22	.6			4.8	122
900	26	.4	17	432	4.1	104
	24	.5			5.0	127
	22	.6			5.8	147
1100	22	.6	19	483	6.5	165
1200	26	.4	17	432	4.7	119
	24	.5			5.0	127
1500	26	.4	19	483	5.4	137
	24	.5			5.7	145
1800	26	.4	17	432	6.0	152
	24	.5			6.3	160
2100	26	.4	17	432	6.2	157
	24	.5			6.7	170
2400	26	.4	19	483	6.5	165
2700	26	.4			7.2	183
3000	26	.4	19	483	7.6	193
3600	26	.4			8.0	203

8.6.5.3 Maximum Bundle Size for Closures

8.6.5.3.1 26 AWG 2-Bank Straight Splice\*

Straight Splice Measurement in Inline Configuration  
(3M™ MS<sup>2</sup>™ Super-Mini Modules 4000-D)

Number of Pair Bridged  
(3M™ MS<sup>2</sup>™ Super-Mini Modules 4000-D and 3M™ MS<sup>2</sup>™ Super-Mate Modules 4005-DPM)

Main Cable Pair Count	Zero	100	200	300	400	600	900	1200	1500	1800	2100	2400	2700	3000
100	1.3	1.7												
200	1.9	2.1	2.4											
300	2.2	2.6	2.7	3.0										
400	2.6	2.9	3.0	3.2	3.7									
600	3.1	3.4	3.5	3.8	4.1	4.4								
900	3.8	4.0	4.2	4.4	4.7	4.9	5.3							
1100	4.0	4.4	4.6	4.8	5.0	5.1	5.6							
1200	4.2	4.5	4.8	5.0	5.2	5.3	5.8	6.3						
1500	4.9	5.1	5.4	5.6	5.7	6.0	6.3	6.7	7.0					
1800	5.4	5.6	5.9	6.0	6.1	6.4	6.6	7.1	7.3	7.6				
2100	5.8	6.1	6.3	6.4	6.5	6.8	7.2	7.5	7.6	7.9	8.3			
2400	6.2	6.5	6.7	6.8	6.9	7.2	7.6	7.9	7.9	8.2	8.6	8.8		
2700	6.6	7.0	7.1	7.2	7.3	7.6	7.8	8.2	8.3	8.6	8.9	9.4	9.6	
3000	7.0	7.4	7.5	7.6	7.7	8.0	8.3	8.6	8.6	8.9	9.3	9.8	10.1	
3600	7.7	8.2	8.3	8.4	8.5	8.7	9.0	9.1	9.2	9.6	9.9	10.3	10.6	10.9

*VALUES IN INCHES*

\*NOTE: For 22 AWG conductors, increase values by 25%  
 For 24 AWG conductors, increase values by 12%  
 If sealant boxes are used, increase values approximately 25%

8.6.5.3.2 26 AWG 3-Bank Straight Splice\*

Straight Splice Measurement in Inline Configuration  
(3M™ MS<sup>2</sup>™ Super-Mini Modules 4000-D)

Number of Pair Bridged  
(3M™ MS<sup>2</sup>™ Super-Mini Modules 4000-D and 3M™ MS<sup>2</sup>™ Super-Mate Modules 4005-DPM)

Main Cable Pair Count	Zero	100	200	300	400	600	900	1200	1500	1800	2100	2400	2700	3000
300	1.8	2.1	2.4	2.7										
600	2.6	2.8	3.1	3.3	3.4	3.7								
900	3.3	3.5	3.8	4.0	4.1	4.3	4.8							
1200	3.9	4.1	4.3	4.5	4.7	5.0	5.5	5.7						
1500	4.5	4.6	4.7	4.9	5.1	5.5	5.9	6.3	6.6					
1800	5.1	5.2	5.3	5.4	5.5	5.9	6.3	6.7	7.0	7.3				
2100	5.5	5.6	5.7	5.8	5.9	6.3	6.7	7.0	7.4	7.7	7.8			
2400	5.9	6.0	6.1	6.2	6.3	6.6	7.0	7.3	7.7	8.0	8.1	8.4		
2700	6.2	6.3	6.4	6.5	6.6	6.9	7.2	7.6	8.0	8.3	8.5	8.7	8.8	
3000	6.5	6.6	6.7	6.8	6.9	7.2	7.5	7.9	8.2	8.6	8.7	9.0	9.1	9.3
3600	6.9	7.0	7.1	7.2	7.3	7.6	7.9	8.3	8.6	8.9	9.2	9.4	9.5	9.7

*VALUES IN INCHES*

\*NOTE: For 22 AWG conductors, increase values by 25%  
 For 24 AWG conductors, increase values by 12%  
 If sealant boxes are used, increase values approximately 25%

# 3M™ MS<sup>2</sup>™ Modular Splicing System Instructions

## 8.6.5.3.3 26 AWG 4-Bank Straight Splice\*

Straight Splice Measurement in Inline Configuration  
(3M™ MS<sup>2</sup>™ Super-Mini Modules 4000-D)

Number of Pair Bridged  
(3M™ MS<sup>2</sup>™ Super-Mini Modules 4000-D and 3M™ MS<sup>2</sup>™ Super-Mate Modules 4005-DPM)

Main Cable Pair Count	Zero	100	200	300	400	600	900	1200	1500	1800	2100	2400	2700	3000
400	2.0	2.1	2.2	2.3	2.5									
600	2.3	2.5	2.6	2.7	2.9	3.1								
900	2.8	3.0	3.1	3.2	3.4	3.6	3.9							
1200	3.2	3.4	3.5	3.6	3.8	4.0	4.3	4.7						
1500	3.7	3.8	3.9	4.0	4.2	4.3	4.7	5.1	5.3					
1800	4.2	4.2	4.3	4.4	4.6	4.8	5.1	5.4	5.7	6.1				
2100	4.6	4.6	4.7	4.8	5.0	5.2	5.6	5.8	6.1	6.4	6.6			
2400	4.9	4.9	5.1	5.2	5.4	5.6	5.9	6.1	6.4	6.7	6.9	7.0		
2700	5.4	5.4	5.5	5.6	5.7	5.9	6.2	6.4	6.7	7.0	7.2	7.4	7.5	
3000	5.7	5.7	5.8	5.9	6.0	6.2	6.5	6.7	7.0	7.3	7.5	7.8	7.9	8.2
3600	6.2	6.3	6.4	6.5	6.6	6.8	7.0	7.3	7.6	7.9	8.2	8.6	8.9	9.4

*VALUES IN INCHES*

**\*NOTE:** For 22 AWG conductors, increase values by 25%  
 For 24 AWG conductors, increase values by 12%  
 If sealant boxes are used, increase values approximately 25%

## 8.6.5.3.4 26 AWG 2-Bank Super-Mate Apparatus Splice\*

Straight Splice Measurement in Inline Configuration  
(3M™ MS<sup>2</sup>™ Super-Mini Modules 4000-D)

Number of Apparatus Pairs  
Unilength Configuration (3M™ MS<sup>2</sup>™ Super-Mate Modules 4005-DPM)

Main Cable Pair Count	Zero	50	100	200	300	400	600	900	1200	1500	1800
50	1.3	1.6									
100	1.6	1.9	2.3								
200	2.3	2.6	2.7	3.3							
300	2.7	3.1	3.3	3.8	4.2						
400	3.1	3.4	3.8	4.2	4.6	5.2					
600	3.7	4.1	4.4	4.8	5.2	5.8	6.3				
900	4.8	5.0	5.2	5.6	5.9	6.3	6.8	7.7			
1200	5.4	5.7	5.9	6.2	6.5	6.8	7.4	8.0	8.4		
1500	6.1	6.4	6.6	6.9	7.1	7.3	7.9	8.6	8.8	9.4	
1800	6.7	7.0	7.2	7.4	7.6	7.8	8.4	9.2	9.4	9.5	10.3
2100	7.3	7.5	7.7	7.9	8.1	8.4	9.0	9.6	9.9	10.2	10.6
2400	7.8	7.9	8.2	8.3	8.6	8.9	9.5	10.0	10.3	10.7	11.0
2700	8.3	8.3	8.6	8.7	9.1	9.5	10.0	10.4	10.8	11.1	11.5
3000	8.6	8.6	9.1	9.1	9.5	9.9	10.5	10.7	11.0	11.4	11.9
3600	9.5	9.5	9.7	9.9	10.2	10.8	11.2	11.4	11.7	12.1	12.4

*VALUES IN INCHES*

**\*NOTE:** For 22 AWG conductors, increase values by 25%  
 For 24 AWG conductors, increase values by 12%  
 If sealant boxes are used, increase values approximately 25%



8.6.5.3.5 26 AWG 3-Bank Super-Mate Apparatus Splice\*

Main Cable Pair Count	Straight Splice Measurement in Inline Configuration (3M™ MS <sup>2</sup> ™ Super-Mate Modules 4005-DPM)												
	Zero	Number of Apparatus Pairs Unilength Configuration (3M™ MS <sup>2</sup> ™ Super-Mate Modules 4005-DPM)											
	100	200	300	600	900	1200	1500	1800	2100				
300	2.2	3.2	3.6	3.6									
600	3.1	4.0	4.4	4.4	5.7							<b>VALUES IN INCHES</b>	
900	4.0	4.8	5.1	5.1	6.2	6.5							
1200	4.9	5.5	5.8	5.8	6.8	7.2	7.8						
1500	5.7	6.3	6.5	6.6	7.3	8.0	8.4	9.1					
1800	6.6	7.1	7.3	7.3	7.9	8.6	9.0	9.5	10.0				
2100	7.3	7.8	8.0	8.0	8.4	9.2	9.5	9.9	10.4	10.6			
2400	7.9	8.3	8.5	8.5	8.9	9.6	9.9	10.3	10.7	11.2			
2700	8.3	8.7	8.9	8.9	9.3	9.9	10.2	10.8	11.4	11.9			
3000	8.7	9.0	9.2	9.3	9.7	10.2	10.9	11.3	11.8	12.4			
3600	9.2	9.6	9.8	9.8	10.2	10.6	11.6	12.0	12.6	13.2			

**\*NOTE:** For 22 AWG conductors, increase values by 25%  
 For 24 AWG conductors, increase values by 12%  
 If sealant boxes are used, increase values approximately 25%

8.6.5.3.6 26 AWG 4-Bank Super-Mate Apparatus Splice\*

Main Cable Pair Count	Straight Splice Measurement in Inline Configuration (3M™ MS <sup>2</sup> ™ Super-Mate Modules 4005-DPM)											
	Zero	Number of Apparatus Pairs Unilength Configuration (3M™ MS <sup>2</sup> ™ Super-Mate Modules 4005-DPM)										
	100	200	300	400	600	900	1200	1500	1800	2100		
400	2.3	2.7	3.1	3.7	3.9							
600	2.7	3.1	3.5	4.0	4.2	5.1						<b>VALUES IN INCHES</b>
900	3.3	3.6	4.0	4.5	4.7	5.6	6.3					
1200	3.9	4.2	4.5	5.0	5.2	6.0	6.5	7.1				
1500	4.5	4.8	5.1	5.5	5.8	6.5	7.0	7.6	7.8			
1800	5.0	5.4	5.6	6.0	6.2	7.0	7.6	8.0	8.4	8.7		
2100	5.6	5.9	6.1	6.5	6.7	7.5	8.2	8.7	9.0	9.4	9.7	
2400	6.2	6.5	6.6	7.0	7.2	8.0	8.8	9.4	9.8	10.6	10.9	
2700	6.7	7.0	7.2	7.5	7.7	8.5	9.3	9.8	10.3	11.2	11.5	
3000	7.3	7.6	7.7	8.0	8.3	8.9	9.8	10.3	10.8	11.6	11.9	
3600	8.5	8.8	8.8	9.1	9.3	9.9	10.7	11.2	11.8	12.4	12.7	

**\*NOTE:** For 22 AWG conductors, increase values by 25%  
 For 24 AWG conductors, increase values by 12%  
 If sealant boxes are used, increase values approximately 25%

8.7 Load Coil Splice "L" (Apparatus)

This splice is utilized where any apparatus having an "in" and "out" is to be added (i.e., load coil, carrier.)

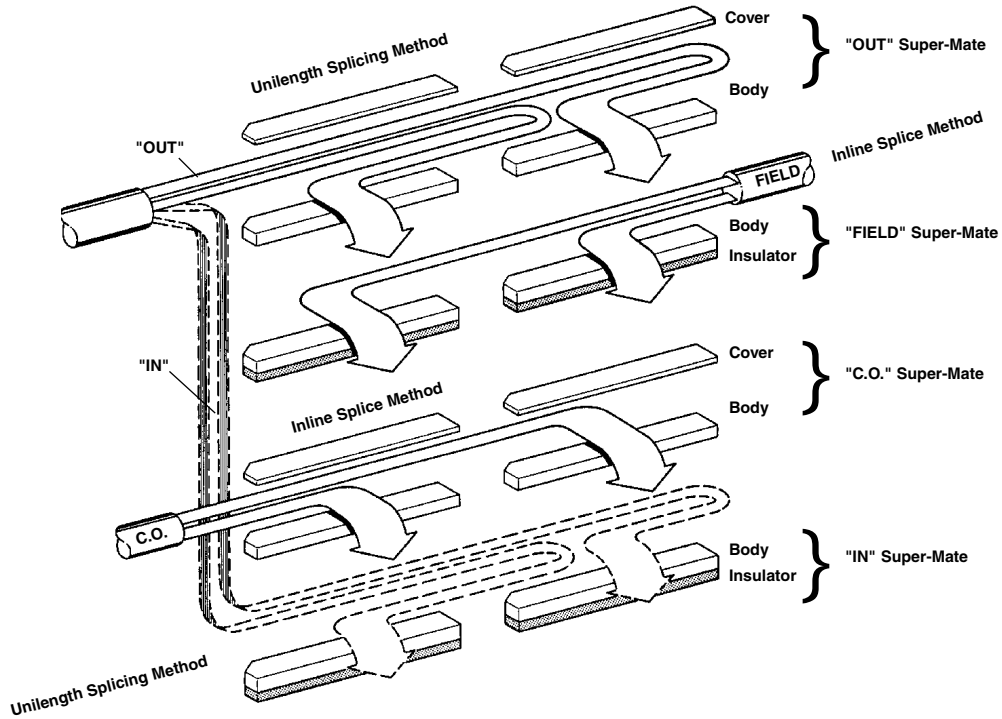

843059

If apparatus is:

1. **Color Coded:** Lay into 3M™ MS<sup>2</sup>™ Super-Mate Module in color code order.
2. **Quaded Pair:** Lay "in" and "out" pairs into corresponding position in appropriate Super-Mate modules.

On feeder routes, engineers should note the proper measurements on the work print where equipment could be added. Construction can then build that splice with Super-Mate modules for simple plugging and unplugging as needed in the future.

Load coil splicing requires more modules than regular splicing. Refer to the apparatus bundle charts to determine if 3 or 4-bank splicing may be needed.

4-Bank Super-Mate Apparatus Splice

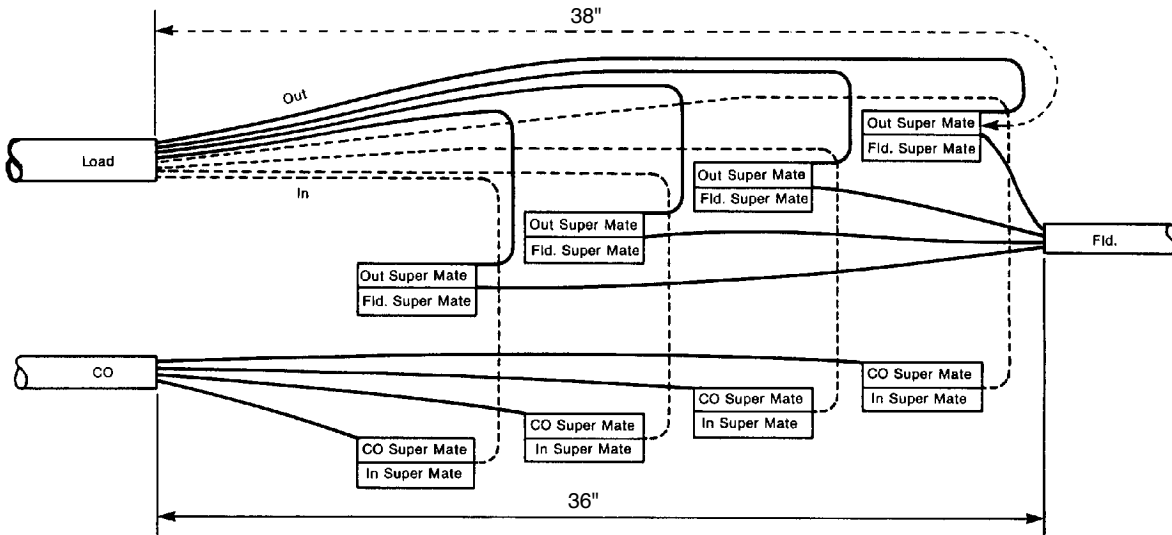

843069

### 8.8 Loading

By building the apparatus/load coil splice with 3M™ MS<sup>2</sup>™ Super-Mate Modules, loading/deloading can be performed without interruption of service.

1. C.O. to FIELD spliced in Super-Mate modules.
2. Crimp load modules using a 3M™ MS<sup>2</sup>™ Hand Presser 4270-A: "IN" to C.O. Super-Mate and "OUT" to FIELD.
3. Separate FIELD and C.O. modules using a 3M™ MS<sup>2</sup>™ Separator Tool 4053-PM.
4. Load modules should be placed in position where the C.O. and FIELD modules can be connected.

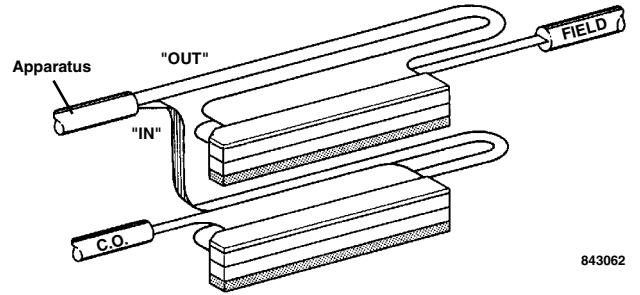

### 8.9 Deloading

By building the apparatus/load coil splice with Super-Mate modules, loading/deloading can be performed without interruption of service.

1. Crimp the corresponding loaded groups together (C.O. to FIELD) using the 4270-A hand presser.
2. Using the 4053-PM separator tool, remove load coil Super-Mate (IN and OUT) from the group.
3. Replace module covers and insulators as required.

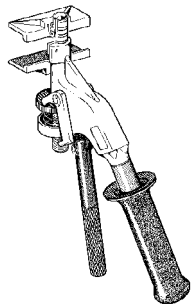
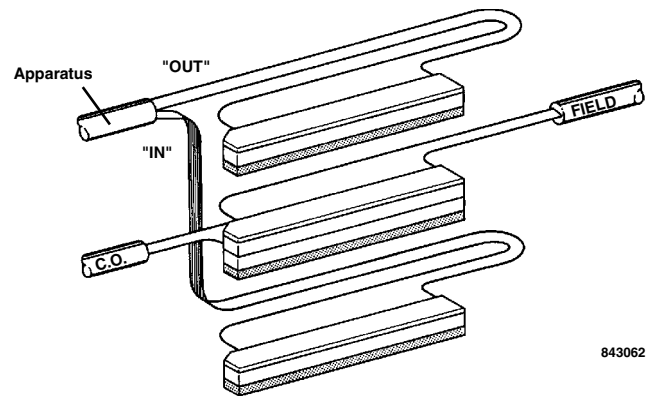

3M™ MS<sup>2</sup>™ Hand Presser 4270-A

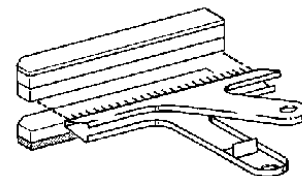

3M™ MS<sup>2</sup>™ Separator Tool 4053-PM

# 3M™ MS<sup>2</sup>™ Modular Splicing System Instructions

## 8.10 Transfer – Access Splice/Facility Splice "F" (Modified Fold Back Configuration)

This splice provides a tagged access to a main feeder cable count by the use of a stub. Future distribution additions, transfers and rearrangements can be made without reentering main cable splices.

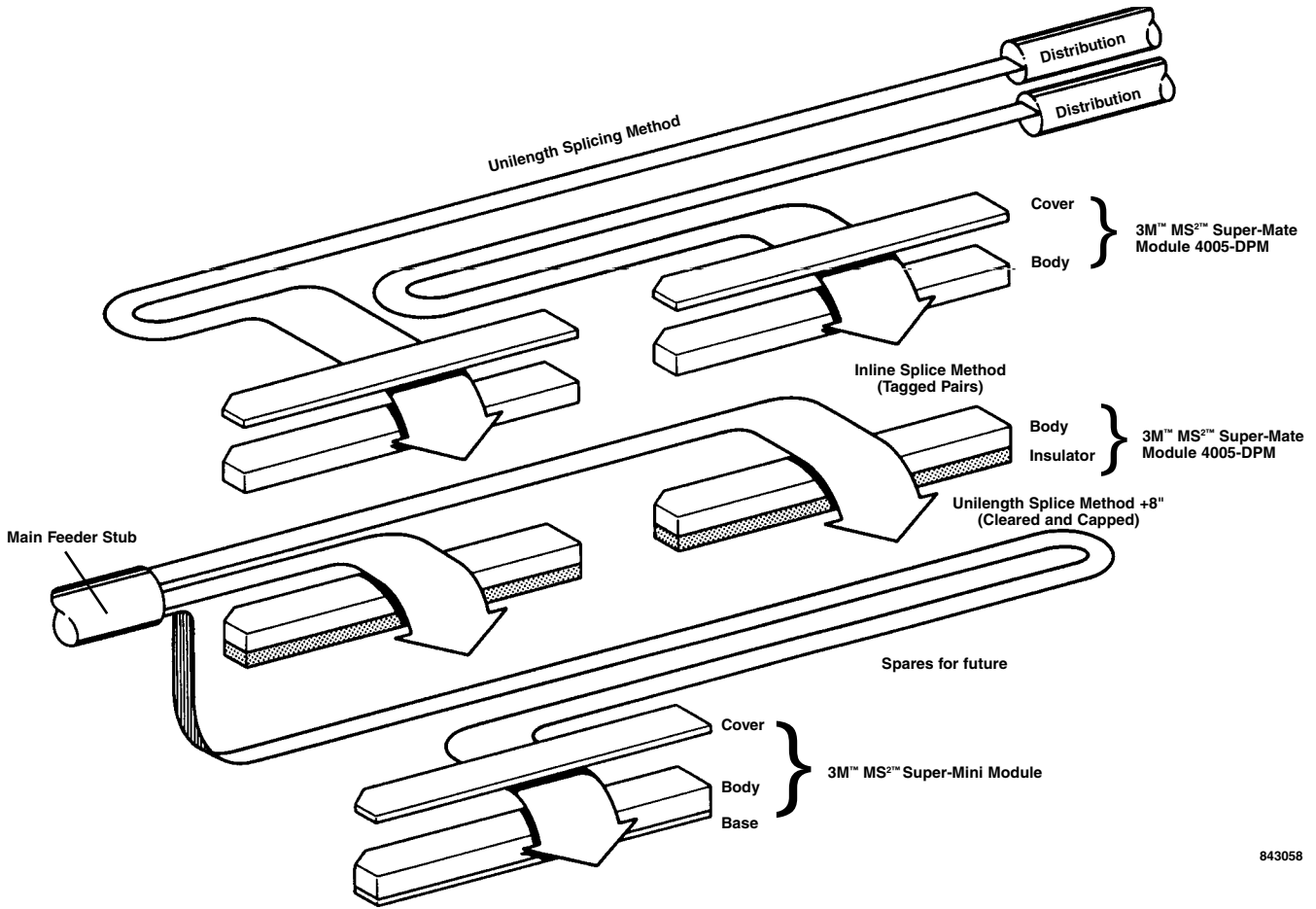

843058

### 8.11 Cable Transfer – Conductor Termination

**New cable** – New conductor groups involved with a transfer must be terminated in 3M™ MS<sup>2</sup>™ Super-Mate Modules according to MS<sup>2</sup> splicing procedures and local transfer plan.

**Existing splices** – If these existing groups are terminated in anything other than a Super-Mate module, they must be converted to Super-Mate modules in numerical sequence or color code order.

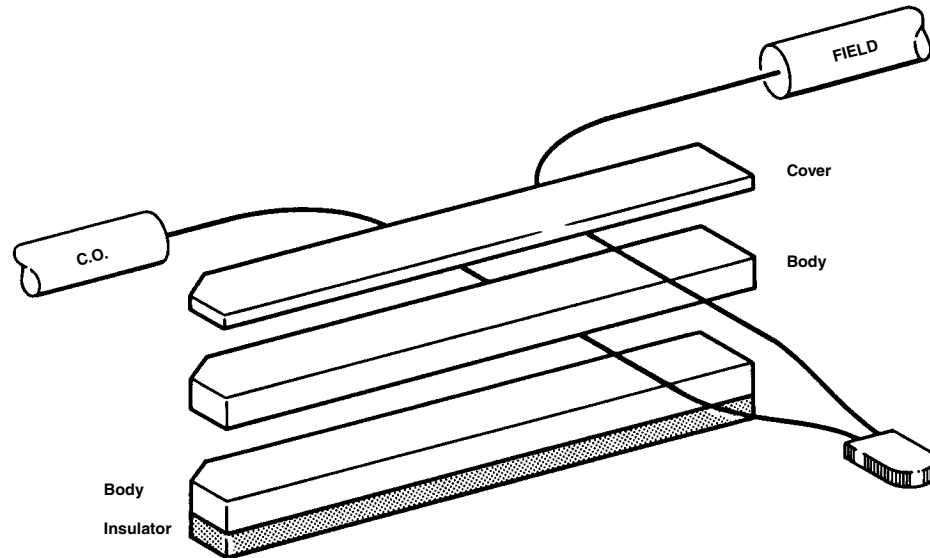

Lay pairs into Super-Mate modules. Make sure that all existing C.O. and FIELD conductors are placed in corresponding wire channels in each Super-Mate module.

# 3M™ MS<sup>2</sup>™ Modular Splicing System Instructions

## 8.12 Cable Transfer – Using the Module

The subscriber, existing and new C.O. count pairs, should be terminated in 3M MS<sup>2</sup> Super-Mate Modules.

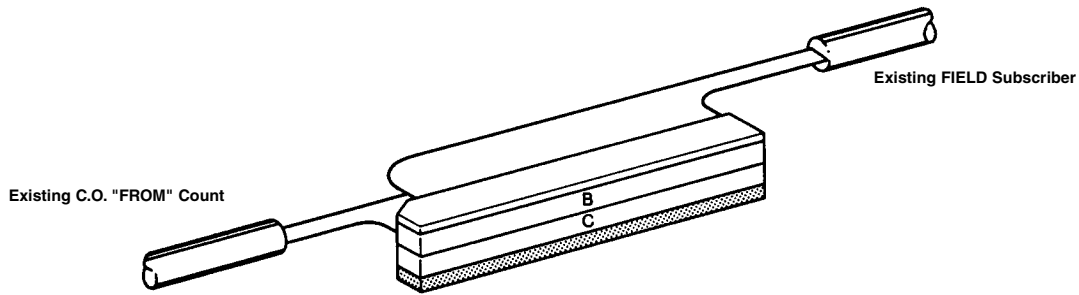

843061

After testing has been completed, identify the proper pair count and crimp the new C.O. count (transfer "TO") module to the subscriber module using a 3M™ MS<sup>2</sup>™ Hand Presser 4270-A.

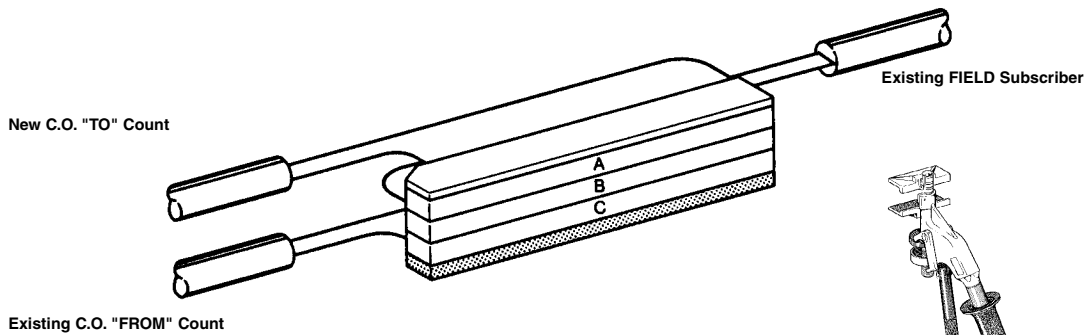

3M™ MS<sup>2</sup>™ Hand Presser 4270-A

Remove old count (transfer "FROM") module from the subscriber module using a 3M™ MS<sup>2</sup>™ Separator Tool 4053-PM. After transfer is complete, make sure that any exposed elements or conductors are protected with a red insulator or cover.

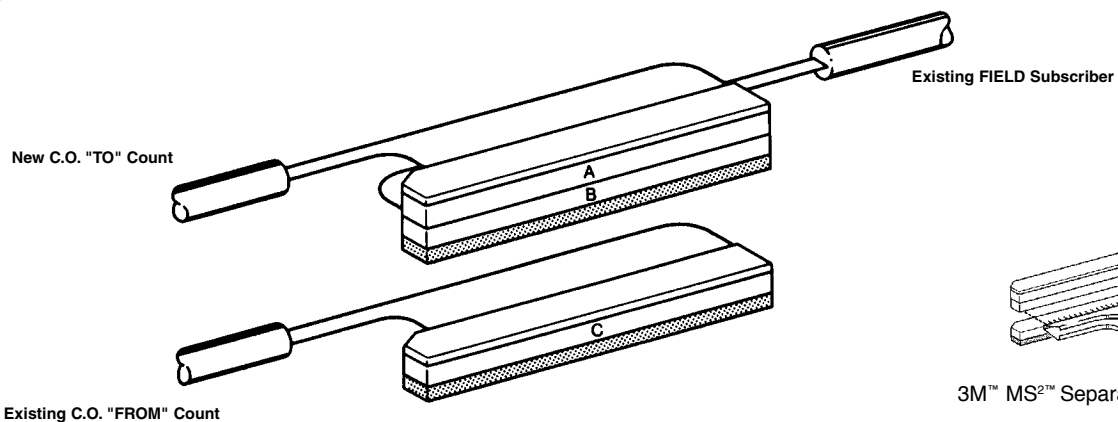

3M™ MS<sup>2</sup>™ Separator Tool 4053-PM

### 8.13 Taper Feeder Splice / Junction Splice "J"

This splice is used when circuits cannot be multiplied because of bridge tap (excessive conductor) and engineering restrictions.

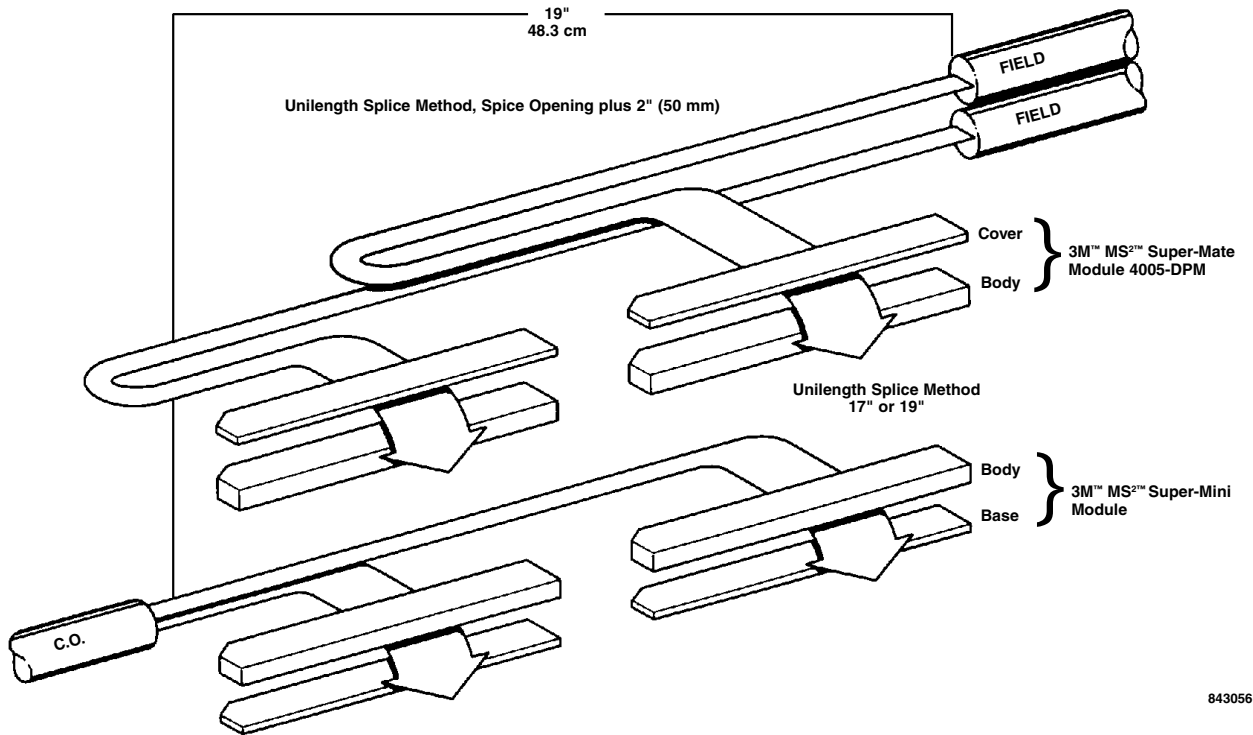

843056

8.14 Bridged Feeder Splice / Multiplied Straight Splice "S"

This splice connects cables that run continuously from the beginning to the end of the main feeder area with the cable count multiplied at specific locations where bridged tap is not a concern.

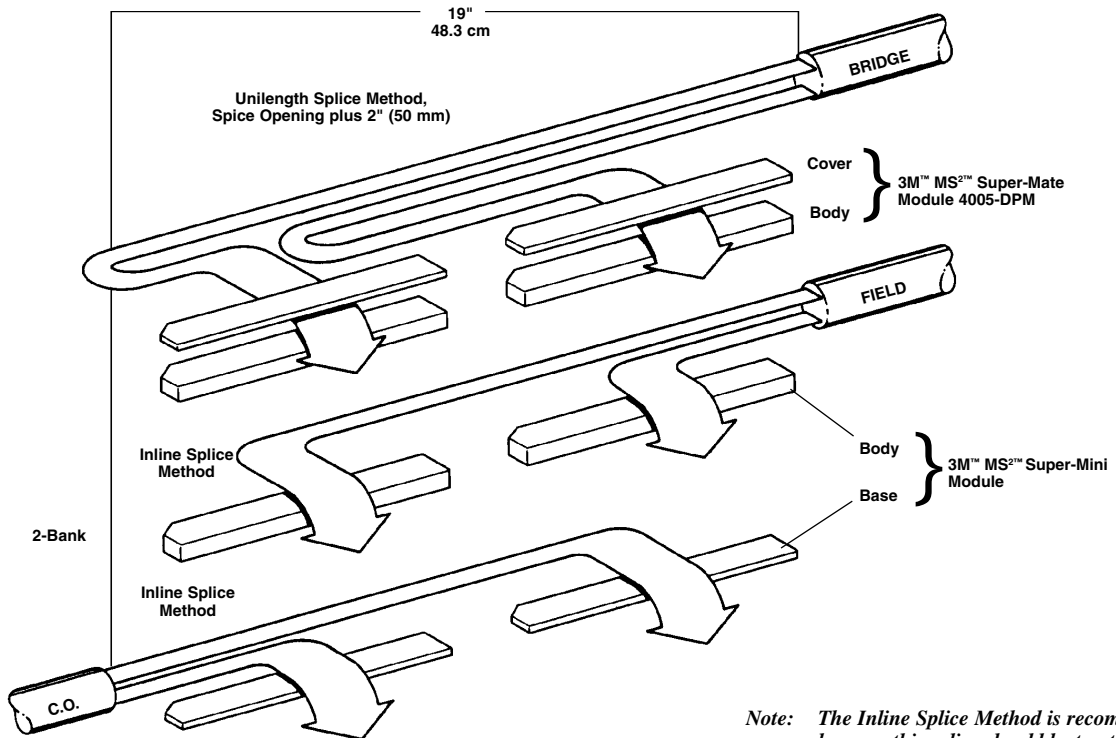

843057

*Note: The Inline Splice Method is recommended because this splice should be treated only as a through connection for the main cable and an access point for multiplied cable.*

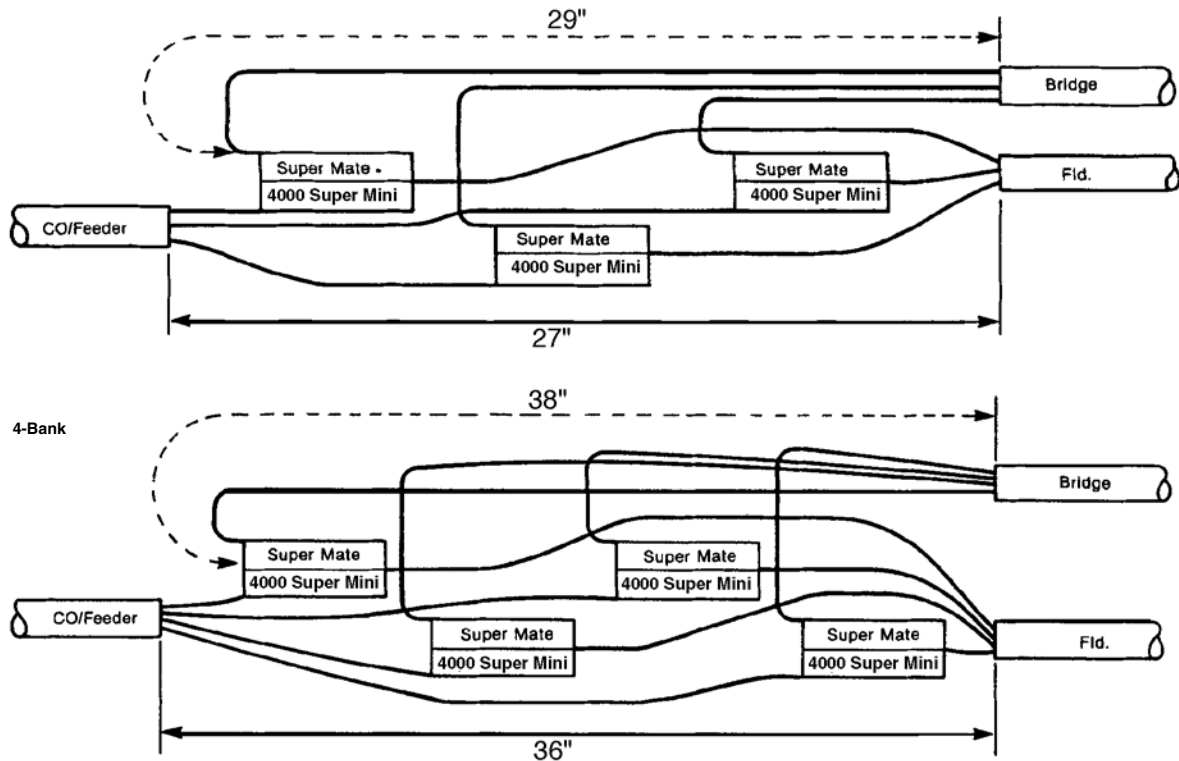

843070



## Appendix A: 3M-TMK Tool Mounting Kit

**PLEASE BECOME FAMILIAR WITH THESE SYMBOLS**



### PARTS IDENTIFICATION



### 1.0 Splicer's Box Mount with A2 Tool Clamp

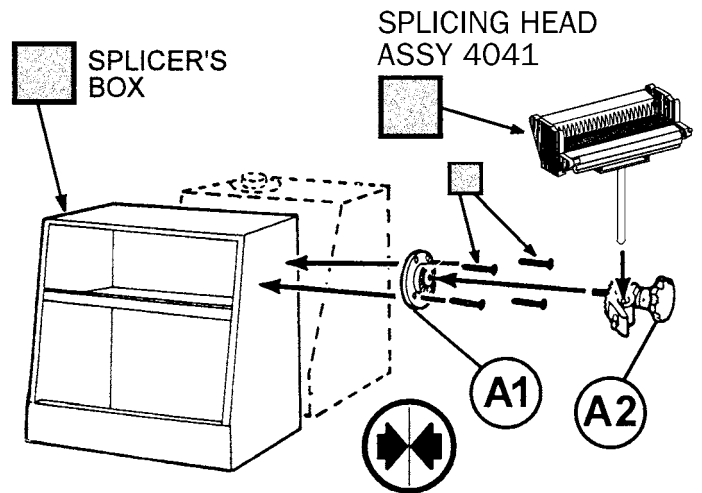

### 2.0 Splicer's Box Mount with A8 90° Mount

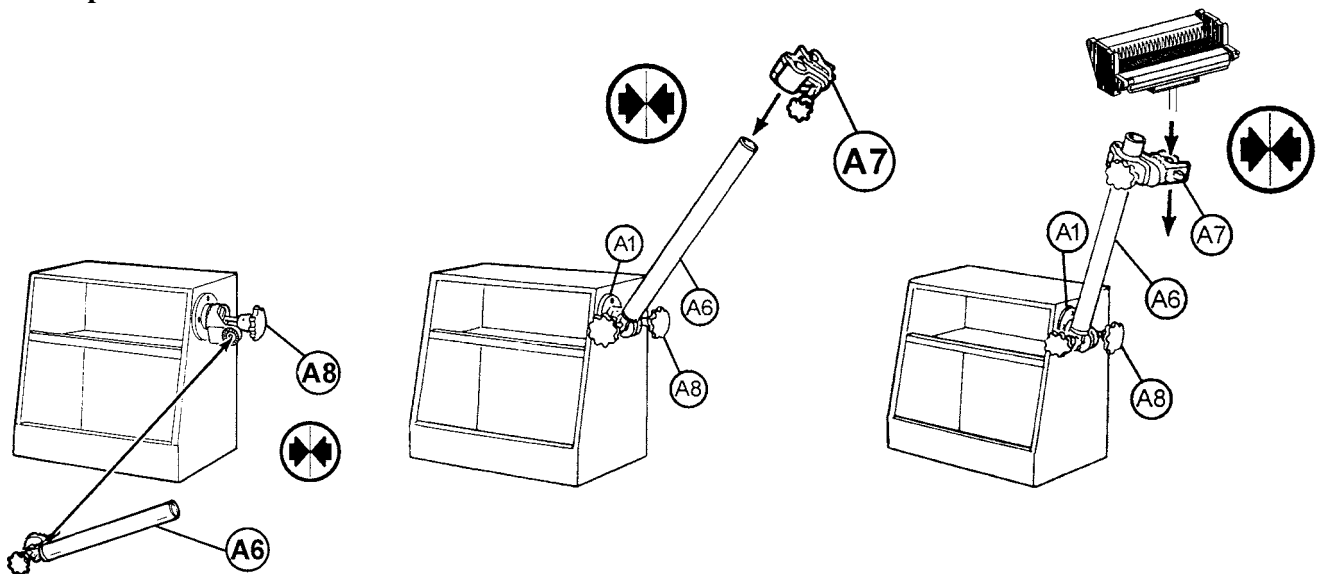

3.0 Rack Mount

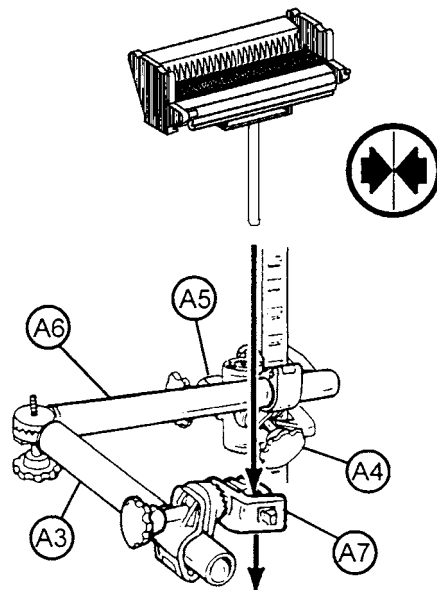
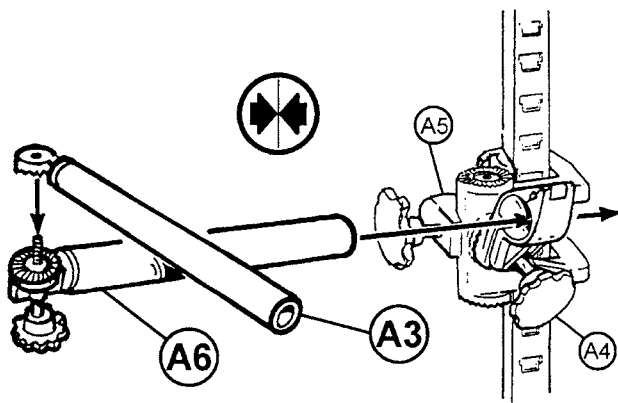
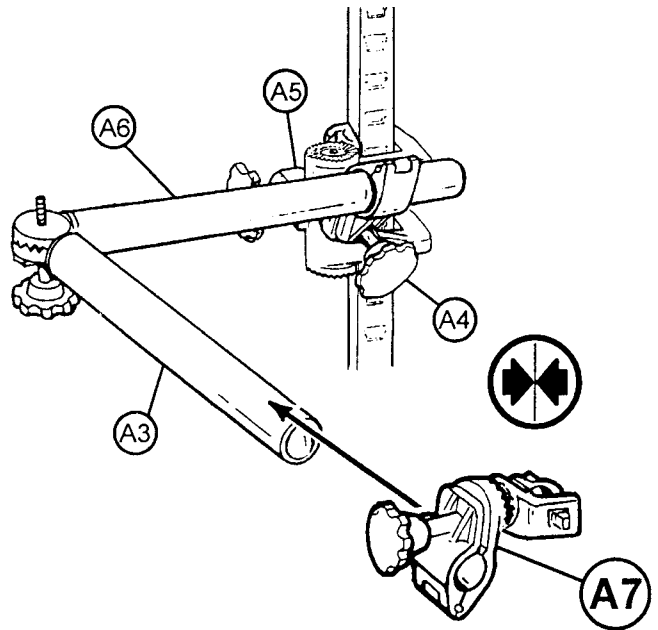
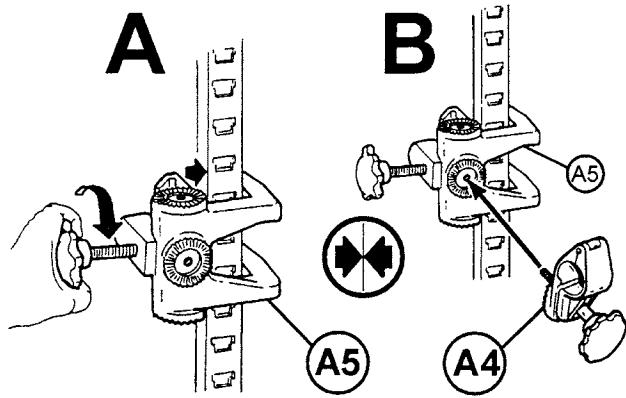

4.0 Pedestal Mount

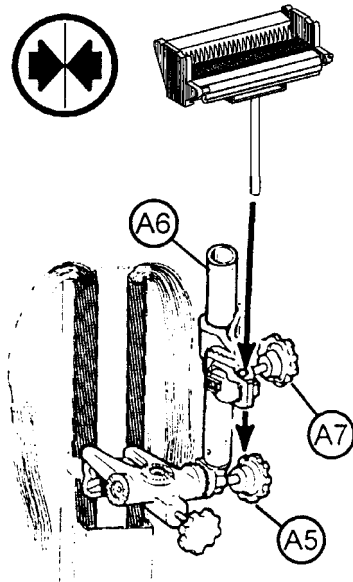
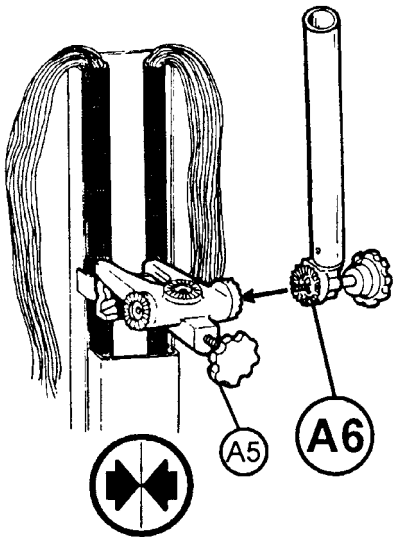
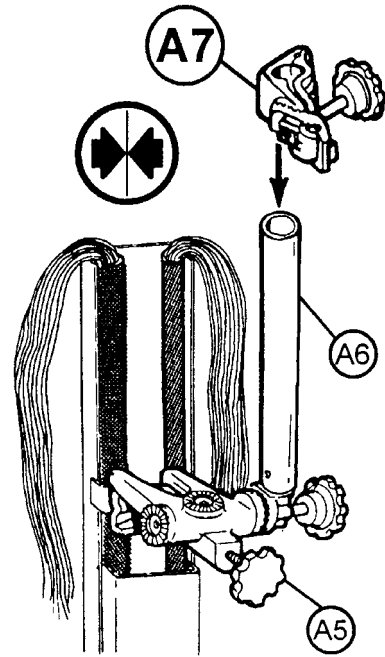
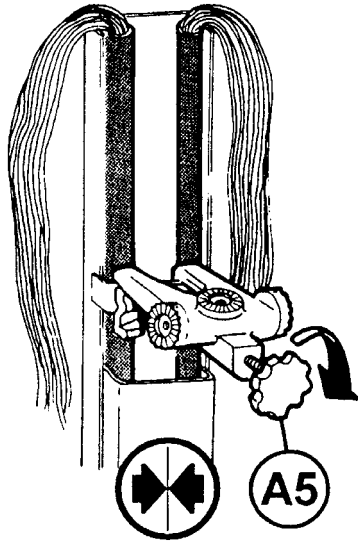

## Appendix B: 3M™ MS<sup>2</sup>™ Universal Splicing Head Support Assembly 4045

### 1.0 General

The 3M™ MS<sup>2</sup>™ Universal Splicing Head Support Assembly 4045 is designed to hold a 3M™ MS<sup>2</sup>™ Splicing Head so it can be used in a variety of locations and positions.

A.

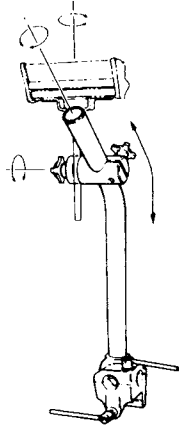

C.

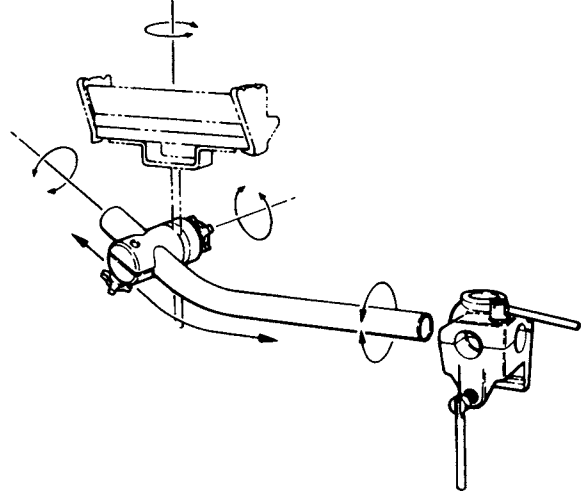

B.

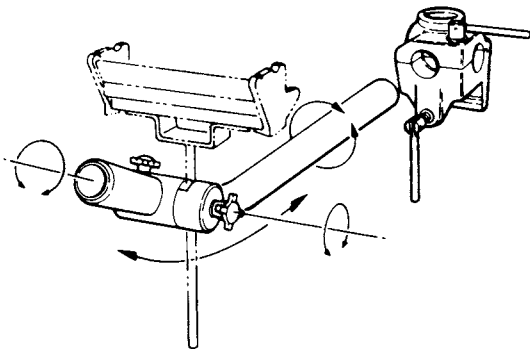

D.

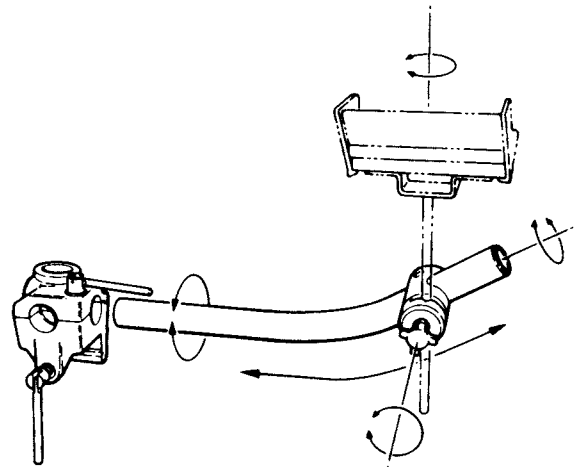

### 2.0 Contents

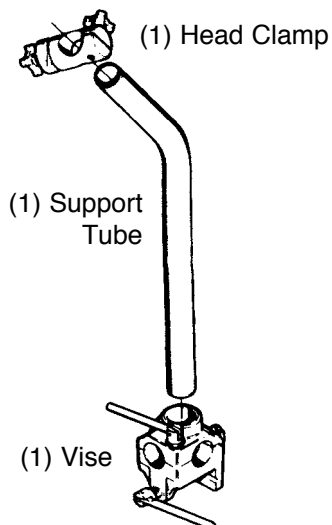

### 3.0 Applications

#### 3.01 Aerial

The vise may be attached directly to the support strand. It may also be attached to the side rail of a ladder which is tied to the strand.

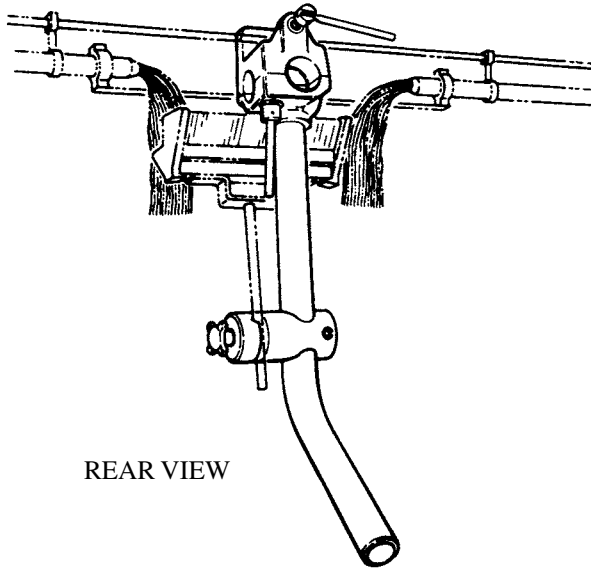

#### 3.03 Buried Plant

The vise may be clamped to the splicer's tool box, stake, or attached directly to a pedestal closure.

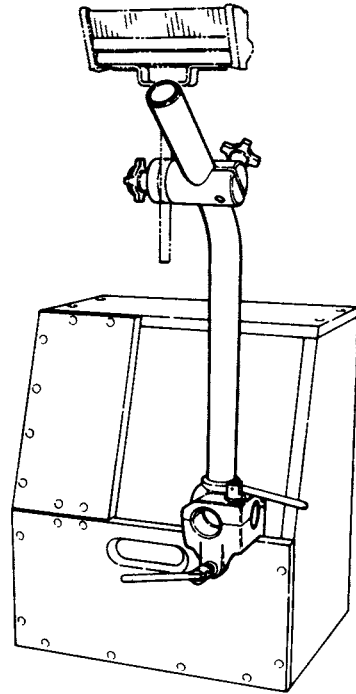

#### 3.02 Riser Splicing

The vise may be attached to a pole step, drive screw, or suspension bolt placed at the required location.

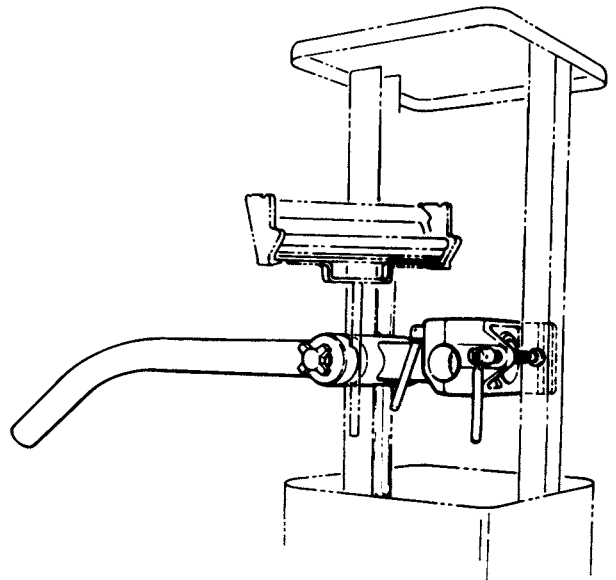
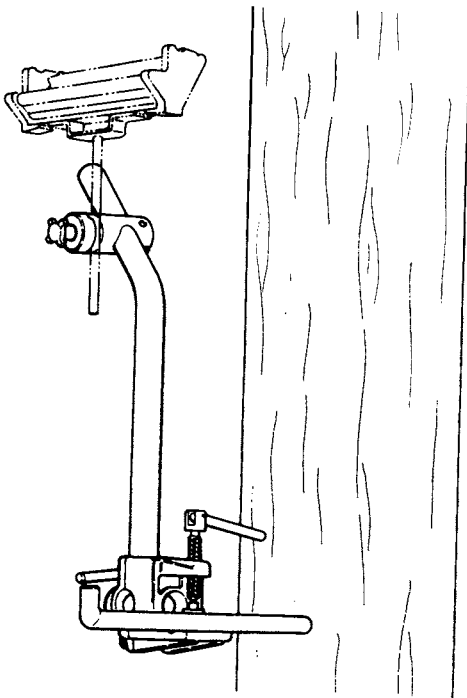

## 3M™ MS<sup>2</sup>™ Modular Splicing System Instructions

### 3.04 Underground

For manhole work, clamp the vise on the splicer's box or manhole racking.

### 3.05 Building and Central Office Splicing

Clamp the vise to a ladder, splicer's box, cable racks, frames, or any suitable support.

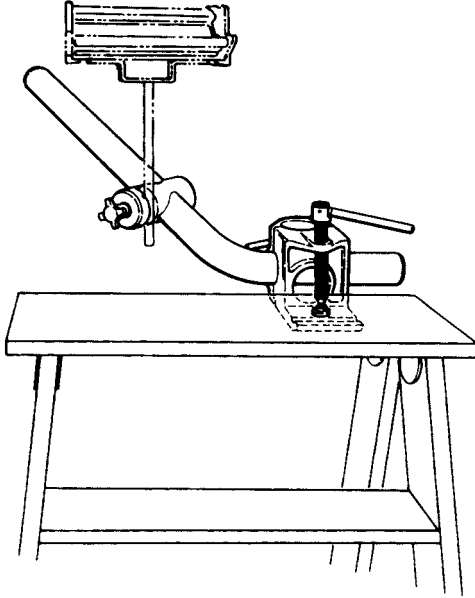







3M, Scotchlok and MS<sup>2</sup> are trademarks of 3M Company.

### **Important Notice**

3M™ MS<sup>2</sup> splicing rigs, tools and modules are engineered to work together to achieve consistently superior performance in the field. Modules from other manufacturers may not meet the tight quality tolerances of 3M modules and may damage the calibration and performance of a 3M rig or tool. Therefore, the published 3M warranty does not extend to any 3M modules spliced in rigs or tools not made by 3M. The warranty on 3M MS<sup>2</sup> splicing rigs and Scotchlok splicing tools can also be voided if used on non-3M modules.

All statements, technical information, and recommendations related to 3M's products are based on information believed to be reliable, but the accuracy or completeness is not guaranteed. Before using this product, you must evaluate it and determine if it is suitable for your intended application. You assume all risks and liability associated with such use. Any statements related to the product which are not contained in 3M's current publications, or any contrary statements contained on your purchase order shall have no force or effect unless expressly agreed upon, in writing, by an authorized officer of 3M.

### **Warranty; Limited Remedy; Limited Liability.**

This product will be free from defects in material and manufacture for a period of 12 months from the time of purchase. **3M MAKES NO OTHER WARRANTIES INCLUDING, BUT NOT LIMITED TO, ANY IMPLIED WARRANTY OF MERCHANTABILITY OR FITNESS FOR A PARTICULAR PURPOSE.** If this product is defective within the warranty period stated above, your exclusive remedy shall be, at 3M's option, to replace or repair the 3M product or refund the purchase price of the 3M product. **Except where prohibited by law, 3M will not be liable for any loss or damage arising from this 3M product, whether indirect, special, incidental or consequential regardless of the legal theory asserted.**



**Communication Markets Division  
3M Telecommunications**

6801 River Place Blvd.  
Austin, TX 78726-9000  
1-800-426-8688

[www.3MTelecommunications.com](http://www.3MTelecommunications.com)

Please Recycle. Printed in USA.  
© 3M 2008. All Rights Reserved.  
78-8130-4094-2-B