

NOTES

- 1. MATERIALS AND FINISHES:
SHELL, HOUSING, BODY,
BARREL, RETAINER RING,
WASHER, COVER, FERRULE
WASHER
CONTACT PINS
BULLET CONTACT
INSULATORS
GASKET

- BRASS, NICKEL PLATING
- BECU, NICKEL PLATING
- PHOSPHOR BRONZE AND BRASS, GOLD PLATING
- BRASS, GOLD PLATING
- PTFE, NATURAL
- RUBBER, RED

- 2. ELECTRICAL:
A. IMPEDANCE: 75 OHM
B. FREQUENCY RANGE: DC -4 GHz

- 3. MECHANICAL:
A. DURABILITY: 500 CYCLES MIN.
B. TEMPERATURE TANGE: -65°C TO +165°C

- 4. ASSEMBLY INSTRUCTIONS:
A. CRIMPED FERRULE HEX CRIMP SIZE .324"
B. CRIMPED CONTACT PIN HEX CRIMP SIZE .068"

5 CABLE ENTRY DIMENSIONS

THIRD ANGLE PROJ.

REVISIONS				
REV	DESCRIPTION	DATE	ECN	APPR
A	RELEASE TO MFG.	12-Jun-18	08641	NB

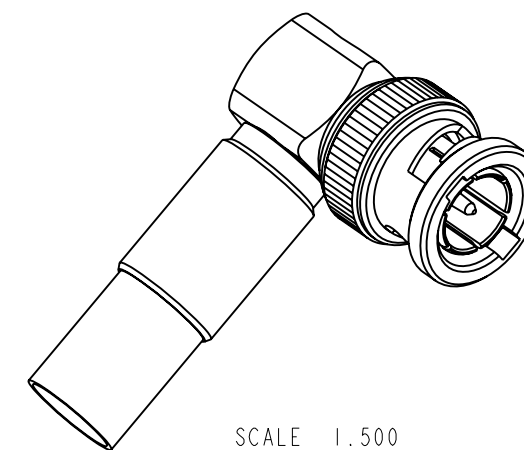
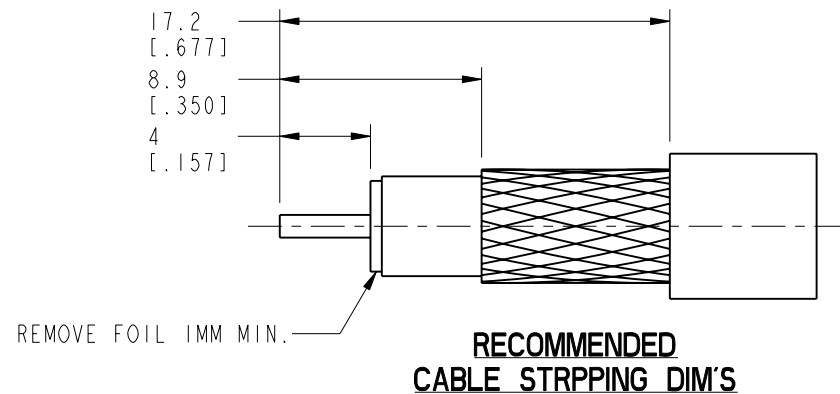

SCALE 1.500

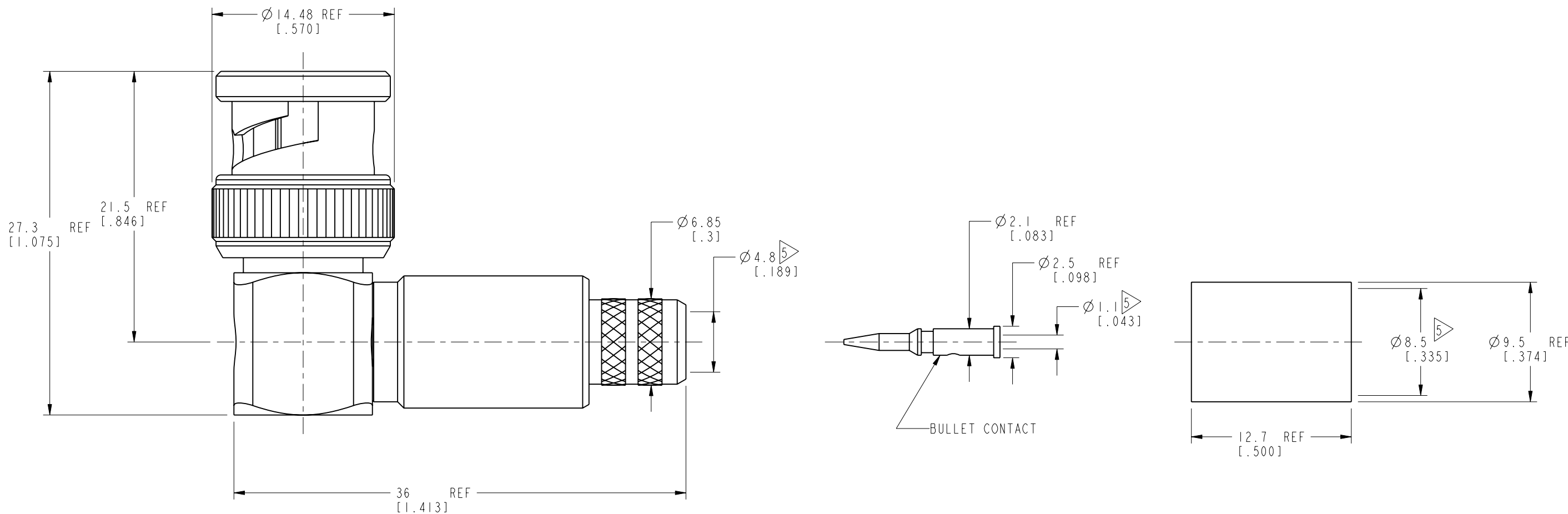

CUSTOMER OUTLINE DRAWING
ALL OTHER SHEETS ARE FOR INTERNAL USE ONLY

UNLESS OTHERWISE SPECIFIED, DIMENSIONS ARE IN METRIC AND TOLERANCES ARE: <0.5mm ±0.05mm 0.5 - 6mm ±0.1mm 6 - 30mm ±0.2mm 30 - 120mm ±0.3mm ANGLES ±1°	MATERIAL	DRAWN	DATE	TITLE		Amphenol RF www.amphenolrf.com
	SEE NOTES	W. ZENG	30-Jul-18	BNC R/A CRIMP PLUG (FOR RG-6/U CABLE)		
NOTICE - These drawings, specifications, or other data (1) are, and remain the property of Amphenol corp. (2) must be returned upon request; and (3) are confidential and not to be disclosed to any person other than those to whom they are given by Amphenol Corp. the furnishing of these drawings, specifications, or other data by Amphenol Corp., or to any other person to anyone for any purpose is not to be regarded by implication or otherwise in any manner licensing, granting rights to permitting such holder or any other person to manufacture, use or sell any product, process or design, patented or otherwise, that may in any way be related to or disclosed by said drawings, specifications, or other data.	REFERENCE	ENGINEER	DATE	SCALE: 1.0:1.0 SHEET 2 OF 2		DRAWING NO. 31-70556
	EAR# 8434	S. DUAN	31-Jul-18	DWG SIZE B		ITEM NO. 31-70556
	REF: B1122A1-NT3G-6U-75	APPROVED	S. HSIEH	DATE	REV A	PART NO. 31-70556
	CONFIGURATION LEVEL: In Work	FINISH	CAD FILE	31-Jul-18		