

REVISIONS					
P	LTR	DESCRIPTION	DATE	DWN	APVD
C5		REVISED PER ECO-16-018632	05APR2017	SK	PO

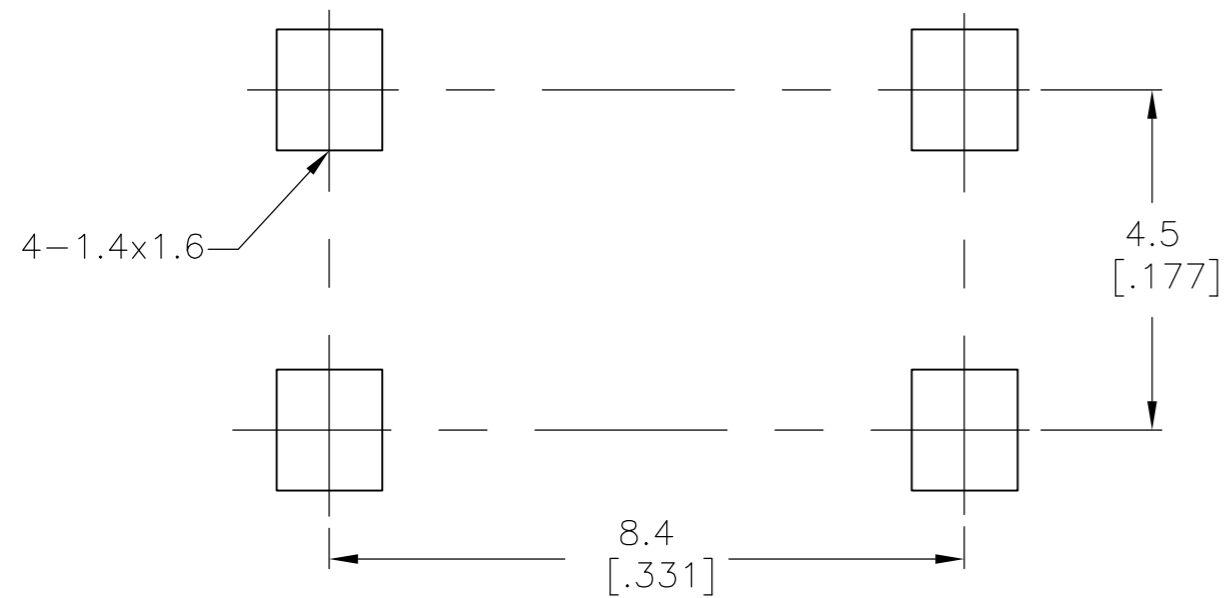
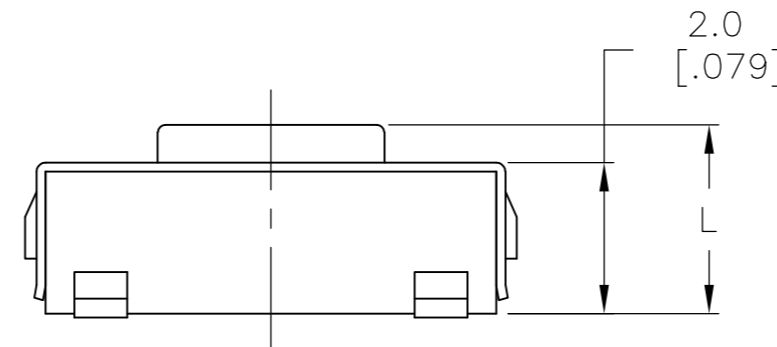
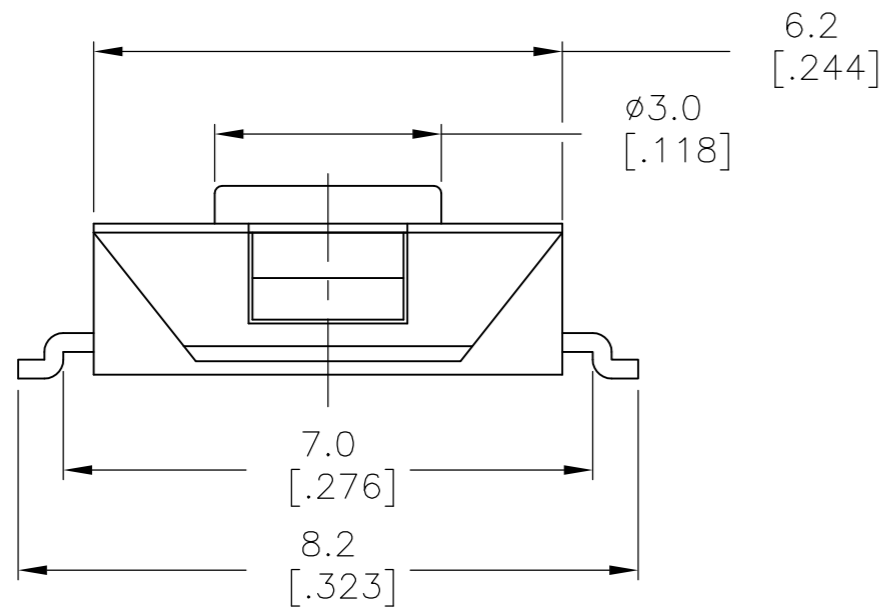
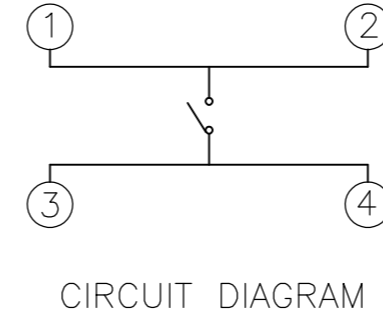
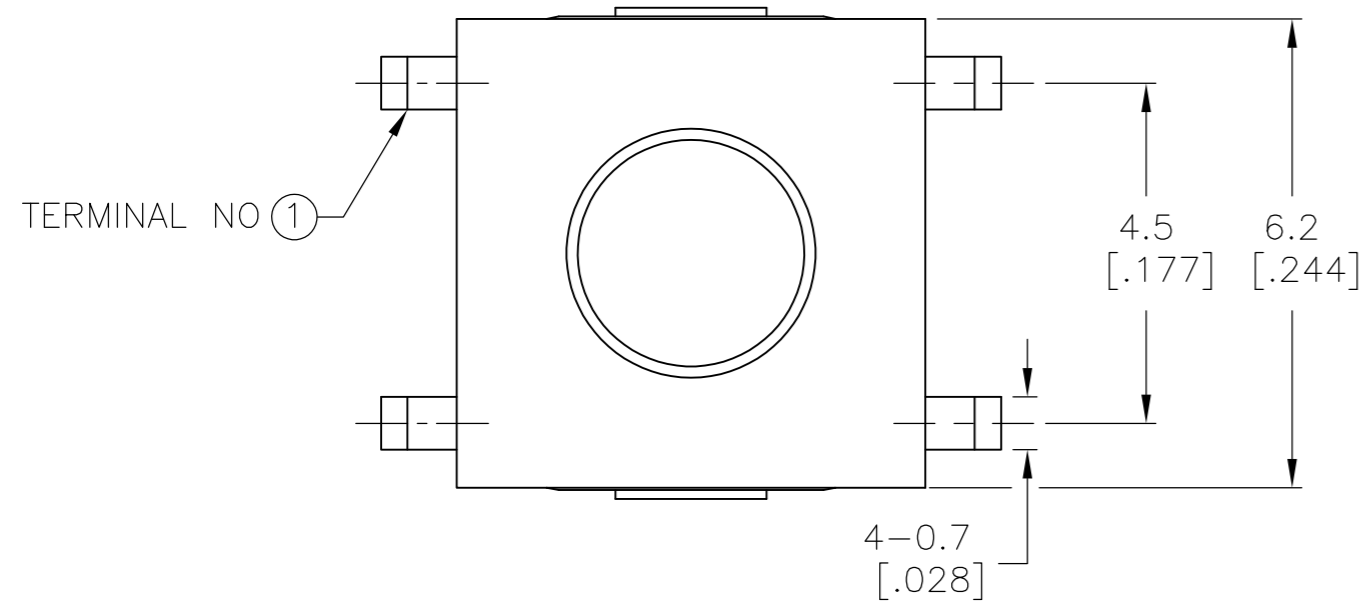

P.C.B MOUNTING SOLDER LAND DIMENSION

SPECIFICATIONS:
 MATERIAL:
 HOUSING, THERMOPLASTIC, UL94-V0, BLACK
 ACTUATOR, THERMOPLASTIC, UL94-V0, COLOR SEE TABLE
 TERMINAL, COPPER ALLOY, PLATE- SILVER OVER NICKEL
 COVER, COPPER ALLOY, TIN PLATE
 CONTACT, STAINLESS STEEL, SILVER PLATE

ELECTRICAL:
 MAX CONTACT RATING: 50MILLIAMPS@24V DC
 MIN CONTACT RATING: 10MICROAMPS@1V DC
 INITIAL CONTACT RESISTANCE, 100 MILLIOHMS MAX, PER EIA-364-23B, EACH POSITION
 INSULATION RESISTANCE, 100 MEGOHM MIN. PER EIA-364-21C EACH POSITION
 DIELECTRIC STRENGTH, 500 V AC FOR 1 MINUTE, PER EIA-364-20B, CONDITION 1, EACH POSITION.
 CONTACT BOUNCE, 10 MILLISECOND MAX, PER EIA 448-1B, METHOD 15

MECHANICAL:
 ACTUATION FORCE, SEE TABLE
 ACTUATION TRAVEL, .25+/- .1 mm
 LIFE EXPECTANCY, SEE TABLE, VALUES GIVEN ARE MINIMUM, (2 CYCLES PER SECOND AND 150% ACTUATION FORCE), PER EIA-448 METHODS 8 & 9
 VIBRATION, PER EIA 364-28D, CONDITION VII, LEVEL E, DURATION 1.5 HOURS
 MECHANICAL SHOCK, PER EIA-364-27C, CONDITION A

ENVIRONMENTAL
 OPERATING TEMPERATURE, -35 TO +85 DEGREES C, PER EIA-448, METHOD 10 (2 CYCLES PER SECOND)
 STORAGE TEMPERATURE, -35 TO +85 DEGREES C
 HUMIDITY AND TEMPERATURE CYCLING PER EIA-364-31B, METHOD III
 THERMAL SHOCK, PER EIA-364-32C, -35 TO +85 DEGREES C
 SOLDERABILITY, PER EIA-364-52, CLASS 2, CATEGORY 1, TEMP, 245 DEGREES C MAX, TIME, 2.5 SECONDS MAX, 95% MINIMUM COVERAGE
 RESISTANCE TO SOLDER HEAT, PER 109-201 COND B.
 1. NO CHANGE IN INITIAL ELECTRICAL AND MECHANICAL CHARACTERISTICS

- NOTES:
 1. TAPE AND REEL PACKAGING PER EIA 481, TAPE WIDTH 12mm, PITCH 8.0mm, 3000 PER REEL
 2. ALL MATERIALS AND FINISHES SHALL COMPLY WITH EU DIRECTIVE 2002/95/EC OF 27JAN2003 (ROHS)

	COLOR	PACKAGING	CYCLE LIFE	FORCE	DIM L	PART NO.
	VIOLET	T&R	1,00,000	260±50gf	2.5mm	1-1571626-0
OBSOLETE	VIOLET	BULK	1,00,000	260±50gf	2.5mm	1571626-9
	RED	T&R	1,000,000	160±50gf	2.0mm	1571626-8
OBSOLETE	RED	BULK	1,000,000	160±50gf	2.0mm	1571626-7
	RED	T&R	1,000,000	160±50gf	2.5mm	1571626-6
OBSOLETE	RED	BULK	1,000,000	160±50gf	2.5mm	1571626-5
	GREEN	T&R	1,000,000	100±50gf	2.5mm	1571626-4
	GREEN	BULK	1,000,000	100±50gf	2.5mm	1571626-3
	IVORY	T&R	1,000,000	50±30gf	2.5mm	1571626-2
OBSOLETE	IVORY	BULK	1,000,000	50±30gf	2.5mm	1571626-1

THIS DRAWING IS A CONTROLLED DOCUMENT.		DWN M.BINNER 22SEP03															
DIMENSIONS: mm [INCHES]		CHK M.SARVER 22SEP03															
TOLERANCES UNLESS OTHERWISE SPECIFIED:		APVD M.SARVER 22SEP03	NAME														
<table border="0"> <tr><td>0 PLC</td><td>± -</td></tr> <tr><td>1 PLC</td><td>± 0.3</td></tr> <tr><td>2 PLC</td><td>± -</td></tr> <tr><td>3 PLC</td><td>± -</td></tr> <tr><td>4 PLC</td><td>± -</td></tr> <tr><td>ANGLES</td><td>± -</td></tr> </table>		0 PLC	± -	1 PLC	± 0.3	2 PLC	± -	3 PLC	± -	4 PLC	± -	ANGLES	± -	PRODUCT SPEC	PUSHBUTTON SWITCH, 6X6 mm, SMT, GULL WING		
0 PLC	± -																
1 PLC	± 0.3																
2 PLC	± -																
3 PLC	± -																
4 PLC	± -																
ANGLES	± -																
MATERIAL		APPLICATION SPEC	SIZE	CAGE CODE	DRAWING NO	RESTRICTED TO											
SEE NOTES		FINISH	WEIGHT	A2	C=1571626	-											
		CUSTOMER DRAWING	SCALE	10:1	SHEET	1 OF 1											
					REV	C5											