

# OSD click™

## 1. Introduction



OSD Click™ is an add-on board in **mikroBUS™** form factor. It's a compact and easy solution for adding monochrome on-screen display (OSD) generator to your design. It features **MAX7456** single-channel monochrome OSD module with integrated EEPROM memory as well as two RCA sockets. OSD Click™ communicates with target board microcontroller via **mikroBUS™** SPI (SDI, SDO, SCK, CS#), RST, LOS, HSYNC and VSYNC lines. The board is designed to use 5V power supply only. LED diode (Green) indicates the presence of power supply.

## 2. Soldering the headers

Before using your click board™, make sure to solder 1x8 male headers to both left and right side of the board. Two 1x8 male headers are included with the board in the package.



1

2



Turn the board upside down so that bottom side is facing you upwards. Place shorter parts of the header pins in both soldering pad locations.

3



Turn the board upward again. Make sure to align the headers so that they are perpendicular to the board, then solder the pins carefully.

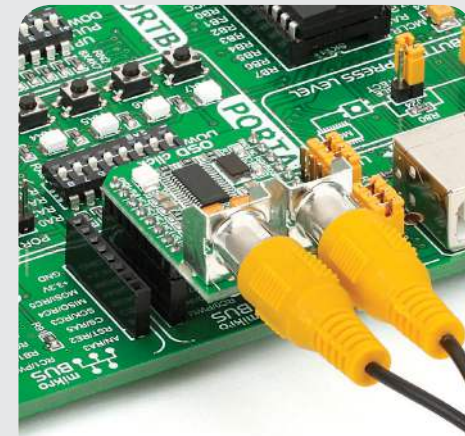

## 4. Essential features

OSD Click™ with its **MAX7456** IC easily displays information such as custom graphics, time and date using 256 user-programmable characters or pictographs. It is NTSC and PAL compatible and displays up to 16 rows x 30 characters. **MAX7456** has internal sync generator. All these features make this board ideal for security switching systems and cameras, industrial applications, consumer electronics and many more.

## 3. Plugging the board in

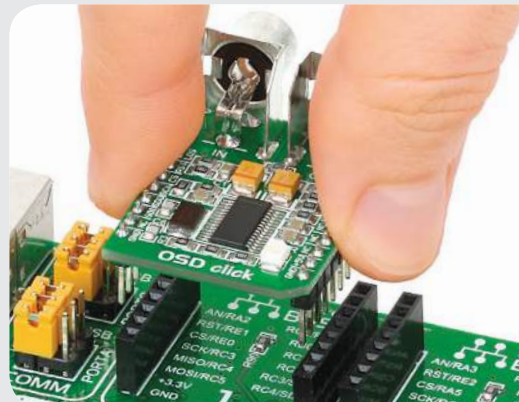

Once you have soldered the headers your board is ready to be placed into desired mikroBUS™ socket. Make sure to align the cut in the lower-right part of the board with the markings on the silkscreen at the mikroBUS™ socket. If all of the pins are aligned correctly, push the board all the way into the socket.

click™  
BOARD  
[www.mikroe.com](http://www.mikroe.com)



OSD click Manual  
ver. 1.00



0 100000 022856

## 5. OSD Click™ Board Schematic

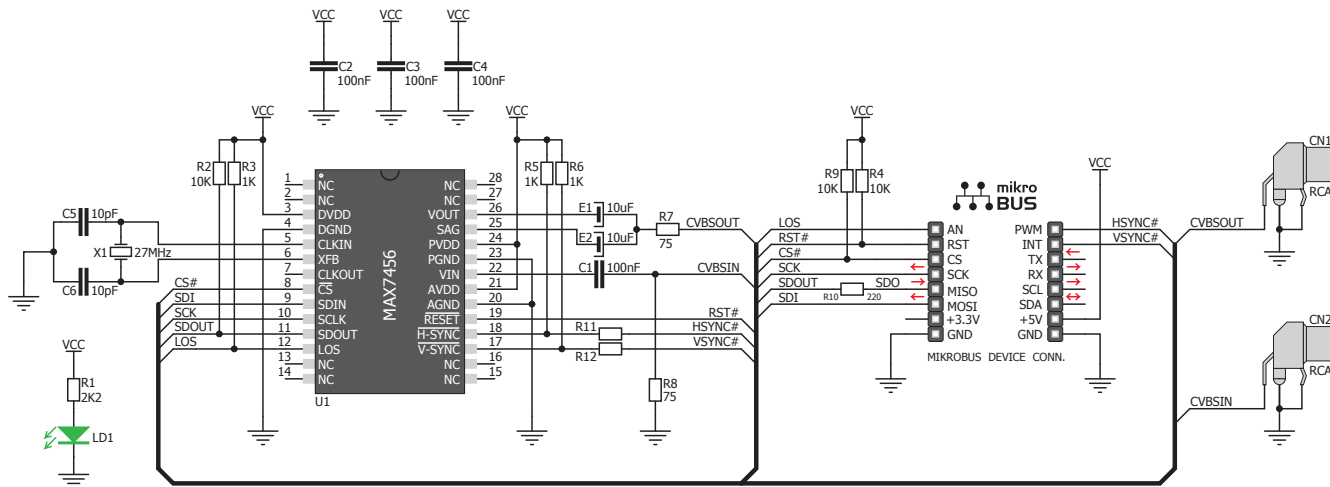

## 6. Composite video sockets

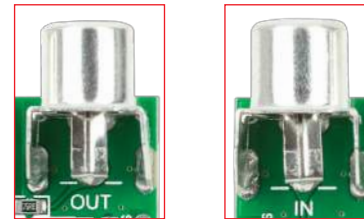

There are two RCA sockets:

**CN1** - composite video OUT.

**CN2** - PAL or NTSC composite video IN.

## 7. Code Examples

Once you have done all the necessary preparations, it's time to get your click board up and running. We have provided the examples for mikroC, mikroBasic and mikroPascal compilers on our **Libstock** website. Just download them and you are ready to start.



## 8. Support

MikroElektronika offers **Free Tech Support** ([www.mikroe.com/esupport](http://www.mikroe.com/esupport)) until the end of product lifetime, so if something goes wrong, we are ready and willing to help!