

### Features

- Ultra Broad Bandwidth : 50 MHz to 50 GHz
- Functional Bandwidth : 50 MHz to 70 GHz
- 0.5 dB Insertion Loss at 50 GHz
- 46 dB Isolation at 50 GHz
- Low Current consumption:
  - 5 V low loss state
  - +10 mA Isolation state
- Silicon Nitride Passivation
- Polymer Scratch protection
- RoHS Compliant\*

### Description

The MA4AGSW1A is an Aluminum-Gallium-Arsenide, single pole, single throw (SPST), absorptive PIN diode switch. The switch features enhanced AlGaAs anodes which are formed using MACOM's patented hetero-junction technology. This technology produces a switch with less loss than conventional GaAs processes. As much as a 0.3 dB reduction in insertion loss can be realized at 50 GHz. These devices are fabricated on an OMCVD epitaxial wafer using a process designed for high device uniformity and extremely low parasitics. The diodes themselves exhibit low series resistance, low capacitance, and fast switching speed. They are fully passivated with silicon nitride and have an additional polymer layer for scratch protection. The protective coating prevents damage to the diode junction and anode air-bridges during handling and assembly. Off chip bias circuitry is required.

### Applications

The output port of this device, J2, is terminated into 50  $\Omega$  during isolation mode, which allows this signal to be absorbed rather than reflected back. This functionality makes it ideal for instrumentation and radar applications. An absorptive switch can be added to other AlGaAs reflective switches to improve isolation VSWR and increase isolation magnitude. The ultra low capacitance of the PIN diodes makes it ideal for usage in low loss and high isolation microwave and millimeter wave switch designs through 70 GHz. The lower series resistance of the AlGaAs diodes reduces the total insertion loss and distortion of the device. AlGaAs PIN switches are used in applications such as switching arrays for radar systems, radiometers, and other multi-function components.

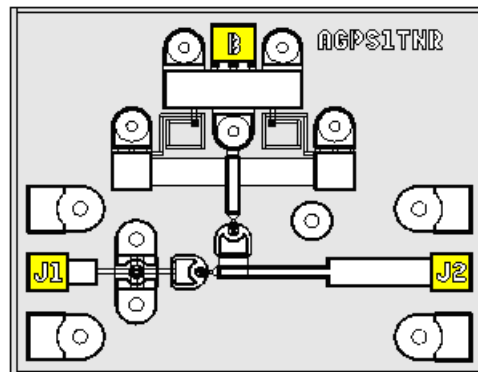

Yellow areas indicate bond pads

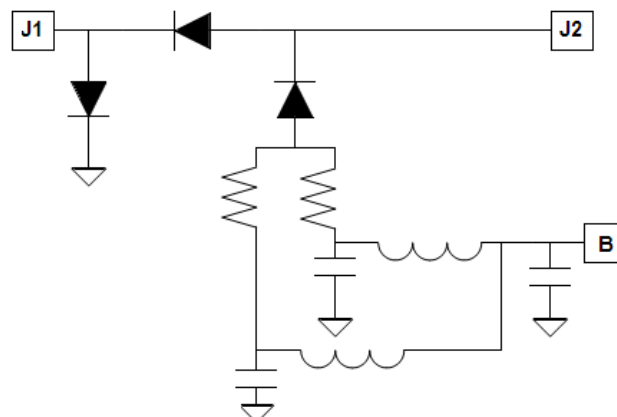

### Ordering Information

Part Number	Package
MA4AGSW1A	Waffle Pack

\* Restrictions on Hazardous Substances, European Union Directive 2011/65/EU.

### Electrical Specifications: $T_A = +25^\circ\text{C}$ (on wafer measurements)

Parameter	Test Conditions	Units	Min.	Typ.	Max.
Insertion Loss (J1 - J2)	-5 V @ J1 and B, 50 GHz	dB	—	1.2	—
Isolation (J1 - J2 (terminated by 50 $\Omega$ ))	10 ma @ J1 and B, 50 GHz	dB	—	30	—
Input Return Loss (J1 - J2)	-5 V @ J1 and B, 50 GHz	dB	—	15	—
Output Return Loss (J2 - J1)	-5 V @ J1 and B, 50 GHz	dB	—	18	—
Isolation (J2 (terminated by 50 $\Omega$ ))	10 ma @ J1 and B, 50 GHz	dB	—	18	—
Switching Speed (J1 - J2) (10% -90% RF Voltage)	$\pm 5$ V PIN TTL Driver 1 MHz Repetition Frequency, 10 GHz	ns	—	10	—

1. Typical switching speed is measured from 10% to 90% of the detected RF voltage driven by a TTL compatible driver. Driver output parallel RC network uses a capacitor between 390 - 560 pF and a resistor between 150 - 220 Ohms to achieve 10 ns rise and fall times.
2. Bias nodes, J1 and B may be connected together

### Absolute Maximum Ratings<sup>3,4</sup>

Parameter	Absolute Maximum
CW RF Incident Power	23 dBm
Breakdown Voltage	25 V
Bias Current	$\pm 25$ mA
Junction Temperature <sup>7,8</sup>	+150°C
Operating Temperature	-55°C to +125°C
Storage Temperature	-55°C to +150°C

3. Exceeding any one or combination of these limits may cause permanent damage to this device.
4. MACOM does not recommend sustained operation near these survivability limits.

### Handling Procedures

Please observe the following precautions to avoid damage:

### Static Sensitivity

These electronic devices are sensitive to electrostatic discharge (ESD) and can be damaged by static electricity. Proper ESD control techniques should be used when handling these devices.

### Typical RF Performance (Probed on Wafer)

**Insertion Loss @ -5 V**

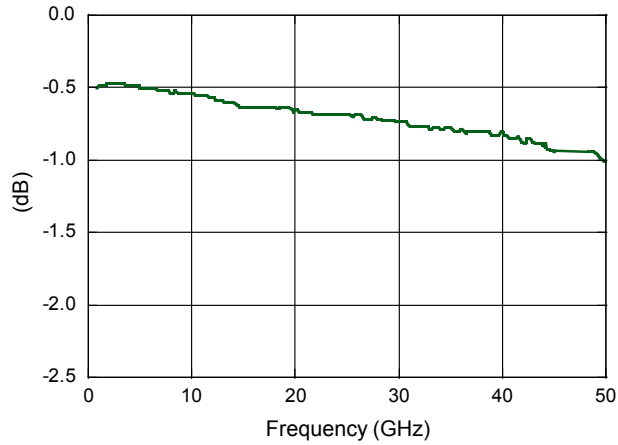

**Isolation @ +10 mA**

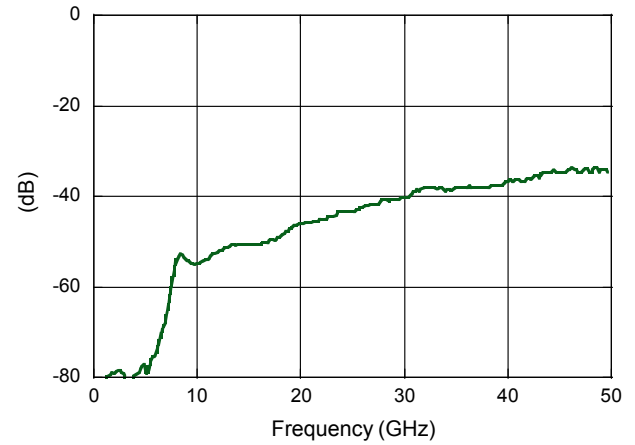

**Input Return Loss @ -5 V**

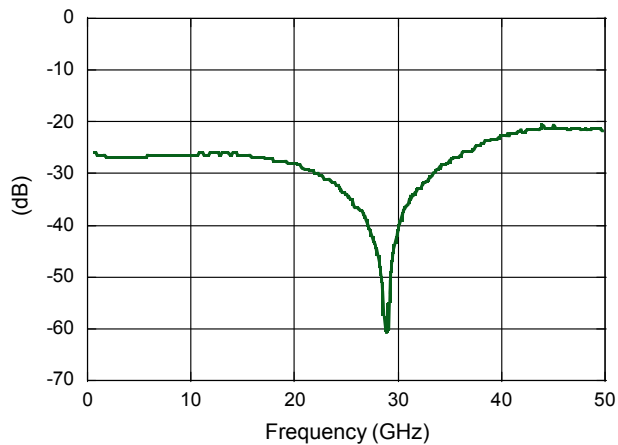

**Output Return Loss @ -5 V (Insertion Loss State)**

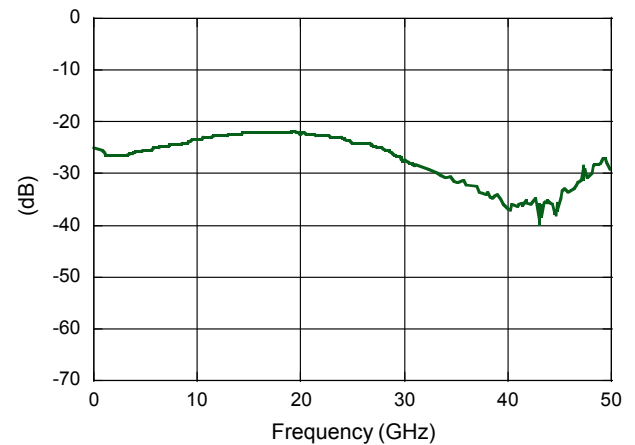

**Output Return Loss @ -5 V (Isolation Loss State)**

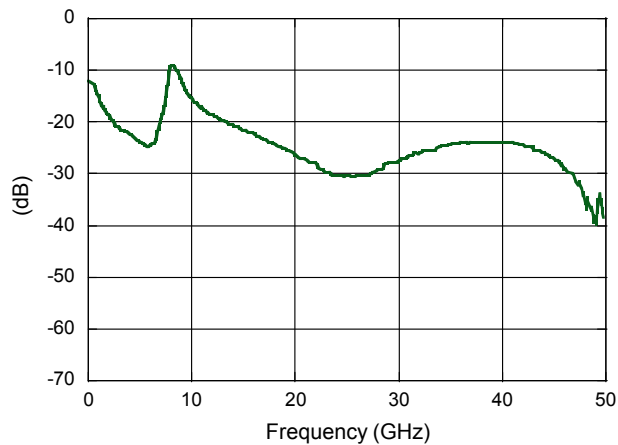

### Operation of the MA4AGSW1A Switch

An external bias network and DC return is required for successful operation of the MA4AGSW1A absorptive SPST AlGaAs PIN diode switch. The backside area of the die is the RF and DC ground return plane. In the low loss state, the series diode is forward biased with negative current at DC Bias B1 and the match diode is biased at 0 V at DC Bias B. In the isolated state, the shunt diode and the match diode are both forward biased at DC Bias B1 and DC Bias B (series diode becomes reverse biased). This isolation state bias results in a good 50 Ω match into Port J2. Typical driver connections are shown in the table below. The bias network design shown in the schematic should yield >30 dB RF to DC isolation.

Available for use in conjunction with MACOM's line of AlGaAs switches are two, fully integrated, broadband, monolithic, bias networks which may be used as an alternative to the suggested individual component bias network shown below. Refer to datasheets for the MA4BN1840-1 and MA4BN1840-2 for additional information.

The lowest insertion loss, P1dB, IP3, and switching speed is achieved by applying a minimum value of  $|-2\text{ V}|$  at DC Bias node, which is achievable with a standard,  $\pm 5\text{ V}$  TTL Controlled PIN Diode Driver.

### MA4AGSW1A Schematic with Bias Network for 10 - 30 GHz<sup>5,6,7</sup>

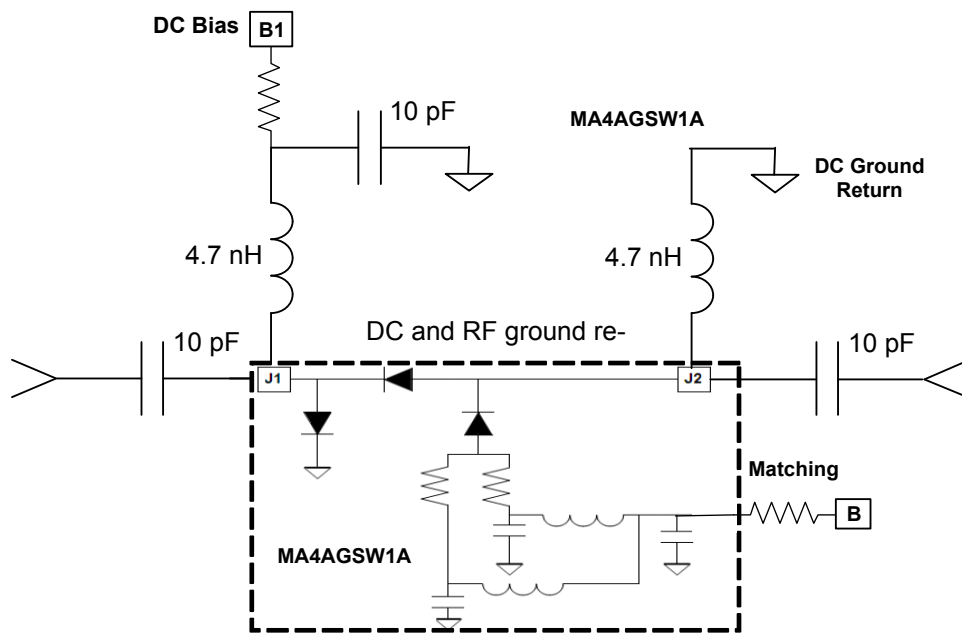

5. DC Bias 1 and DC Bias B nodes can be connected together.
6. Diode junction forward bias voltage,  $\Delta V_F @ 10\text{ mA} \sim 1.35\text{ V} @ +25^\circ\text{C}$ .
7. External resistor values at ports "B" and "B1" can be chosen by subtracting 1.35 V voltage drop from the DC supply voltage, and dividing by the desired forward current. For port "B", subtract 70 ohms from this value to account for the internal termination resistors.

### Typical Driver Connections

J1 - J2 Low Loss: Good VSWR @ J1 & J2	J1 - J2 Isolation: Good VSWR @ J2
DC Bias 1 = -10 mA	DC Bias 1 = +10 mA
DC Bias B = -5 V	DC Bias B = +10 mA

### Chip Dimensions and Bonding Pad Locations (In Yellow)

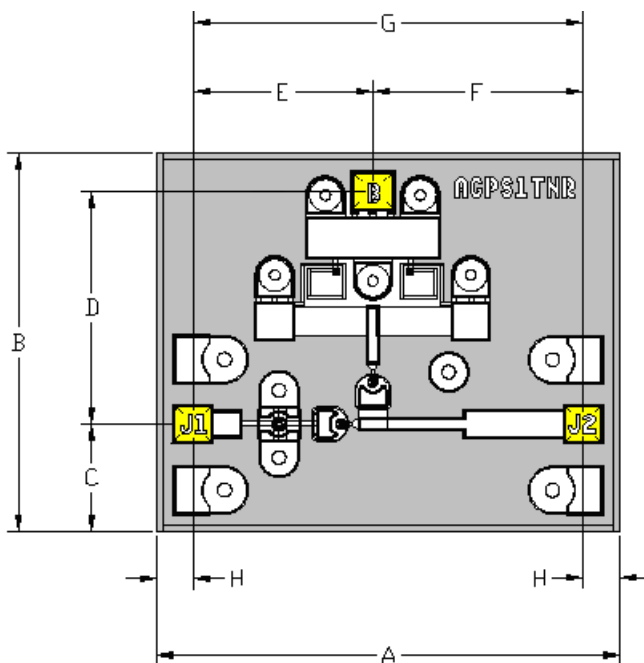

Dimension	mils		mm	
	Min	Max	Min	Max
A	44.9	46.9	1.14	1.19
B	36.9	38.9	0.94	0.99
C	10.4	11.4	0.26	0.29
D	22.8	23.4	0.58	0.59
E	17.3	17.9	0.44	0.45
F	20.3	20.9	0.52	0.53
G	37.9	38.5	0.96	0.98
H	3.4	4.4	0.09	0.11
Thickness	3.5	4.5	0.09	0.11

### Assembly Instructions

#### Cleanliness

These chips should be handled in a clean environment.

#### Static Sensitivity

These Devices are considered ESD Class 1A HBM. Proper ESD techniques should be used when handling these devices.

#### General Handling

The protective polymer coating on the active areas of the die provides scratch and impact protection, particularly for the metal air bridge, which contacts the diode's anode. Die should primarily be handled with vacuum pickups, or alternatively with plastic tweezers.

### Assembly Technique

The MA4AGSW1A, AlGaAs switch is designed to be mounted with electrically conductive silver epoxy or with a lower temperature solder perform, which does not have a rich tin content.

#### Solder Die Attach

All die attach and bonding methods should be compatible with gold metal. Solder which does not scavenge gold, such as 80/20, Au/Sn or Indalloy #2 is recommended. Do not expose die to temperatures greater than 300°C for more than 10 seconds.

#### Electrical Conductive Epoxy Die Attach

Use a controlled thickness of approximately 2 mils for best electrical conductivity and lowest thermal resistance. Cure epoxy per manufacturer's schedule. Typically 150°C for 1 hour.

#### Ribbon / Wire Bonding

Thermo-compression wedge or ball bonding may be used to attach ribbons or wire to the gold bonding pads. A 1/4 x 3 mil gold ribbon is recommended on all RF ports and should be kept as short as possible for the lowest inductance and best microwave performance. For more detailed handling and assembly instructions, see Application Note M541.

MACOM Technology Solutions Inc. All rights reserved.

Information in this document is provided in connection with MACOM Technology Solutions Inc ("MACOM") products. These materials are provided by MACOM as a service to its customers and may be used for informational purposes only. Except as provided in MACOM's Terms and Conditions of Sale for such products or in any separate agreement related to this document, MACOM assumes no liability whatsoever. MACOM assumes no responsibility for errors or omissions in these materials. MACOM may make changes to specifications and product descriptions at any time, without notice. MACOM makes no commitment to update the information and shall have no responsibility whatsoever for conflicts or incompatibilities arising from future changes to its specifications and product descriptions. No license, express or implied, by estoppel or otherwise, to any intellectual property rights is granted by this document.

THESE MATERIALS ARE PROVIDED "AS IS" WITHOUT WARRANTY OF ANY KIND, EITHER EXPRESS OR IMPLIED, RELATING TO SALE AND/OR USE OF MACOM PRODUCTS INCLUDING LIABILITY OR WARRANTIES RELATING TO FITNESS FOR A PARTICULAR PURPOSE, CONSEQUENTIAL OR INCIDENTAL DAMAGES, MERCHANTABILITY, OR INFRINGEMENT OF ANY PATENT, COPYRIGHT OR OTHER INTELLECTUAL PROPERTY RIGHT. MACOM FURTHER DOES NOT WARRANT THE ACCURACY OR COMPLETENESS OF THE INFORMATION, TEXT, GRAPHICS OR OTHER ITEMS CONTAINED WITHIN THESE MATERIALS. MACOM SHALL NOT BE LIABLE FOR ANY SPECIAL, INDIRECT, INCIDENTAL, OR CONSEQUENTIAL DAMAGES, INCLUDING WITHOUT LIMITATION, LOST REVENUES OR LOST PROFITS, WHICH MAY RESULT FROM THE USE OF THESE MATERIALS.

MACOM products are not intended for use in medical, lifesaving or life sustaining applications. MACOM customers using or selling MACOM products for use in such applications do so at their own risk and agree to fully indemnify MACOM for any damages resulting from such improper use or sale.