

DO NOT SCALE FROM THIS PRINT

DESIGNED & DIMENSIONED IN MILLIMETERS

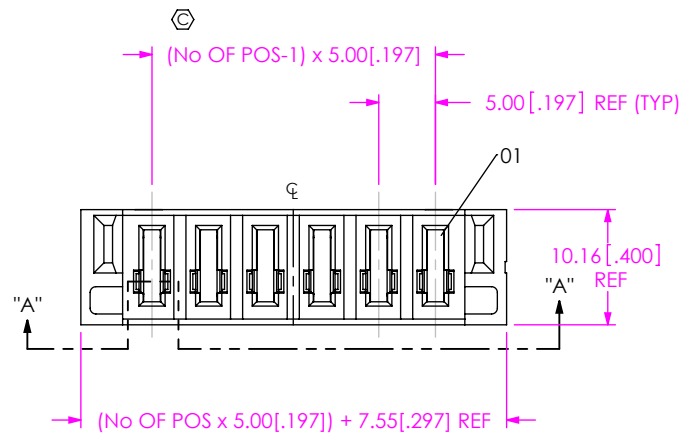

FIG 1
MPS-06-7.70-01-X-V SHOWN

MPS-XX-X.XX-XX-X-V-XX

No OF POSITIONS
-02, -03, -04, -05, -06, -08

LEAD STYLE
-7.70

TAIL LENGTH
-01: FOR 1.57[.062] THICK PCB (USE SUB-C-214-XX.XX-01-X)
-03: FOR 2.36[.093] THICK PCB (USE SUB -C-214-XX.XX-03-X)

OPTION
-LC: LOCKING CLIP (SEE FIG 2, SHT 2)

VERTICAL

PLATING SPECIFICATION
-L: SEE TABLE 2, SHT 2
-T: SEE TABLE 2, SHT 2

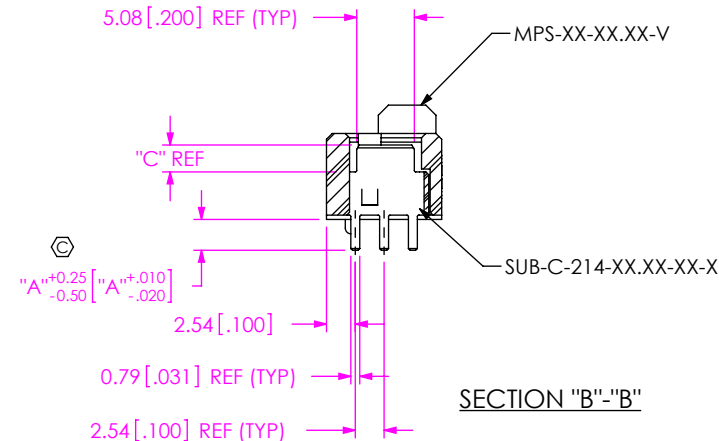
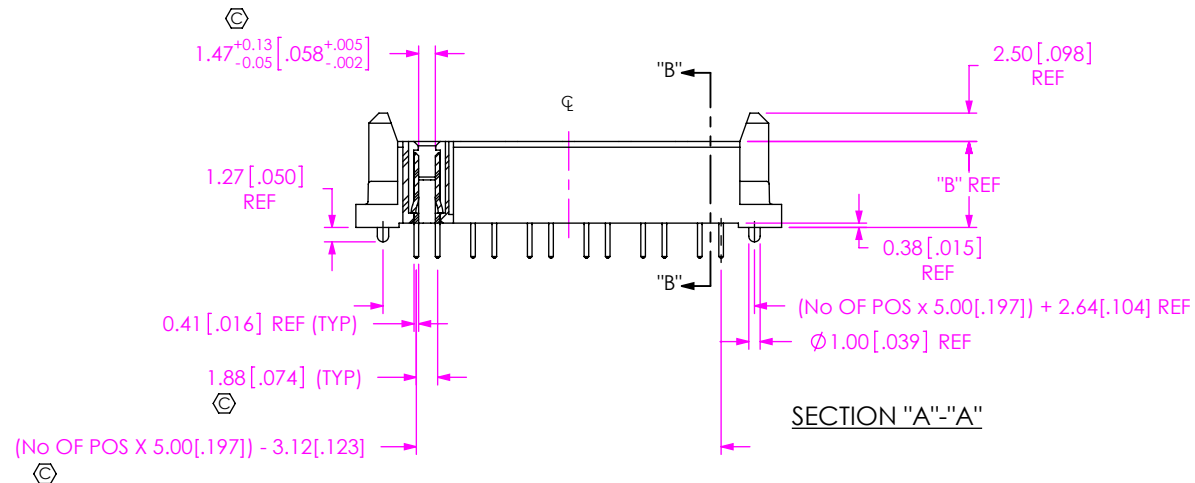
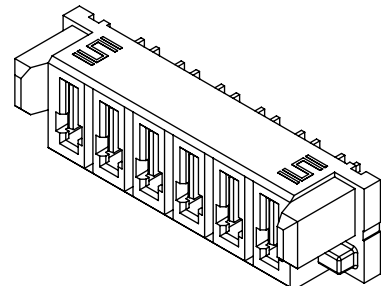

TABLE 1						
PART NUMBER	BODY	CONTACT SUB-ASSEMBLY	"A"	"B"	"C"	STACK HEIGHT
						MPT-6.30-X-V-XX
MPS-XX-7.70-01-X-V-XX	MPS-XX-07.70-V	SUB-C-214-07.70-01-X	2.72 [0.107]	7.58 [0.298]	2.37 [0.094]	14mm
MPS-XX-7.70-03-X-V-XX	MPS-XX-07.70-V	SUB-C-214-07.70-03-X	3.52 [0.139]			



- NOTES:
- ⊕ REPRESENTS A CRITICAL DIMENSION.
 - BURR ALLOWANCE: 0.038[.0015] MAX.
 - MINIMUM PUSHOUT FORCE: 4.45N[1.0 LB].
 - PARTS TO BE PACKAGED IN TRAYS.
 - NOTE DELETED.
 - MINIMUM -LC PULL OUT FORCE: 2.23 N [0.5 LB]
 - NOTE DELETED.

UNLESS OTHERWISE SPECIFIED, DIMENSIONS ARE IN MILLIMETERS.

TOLERANCES ARE:

DECIMALS ANGLES

.X: ±0.3 [0.1] 2°

.XX: ±0.13 [0.05]

.XXX: ±0.051 [0.020]

PROPRIETARY NOTE

THIS DOCUMENT CONTAINS CONFIDENTIAL AND PROPRIETARY INFORMATION AND ALL DESIGN, MANUFACTURING, REPRODUCTION, USE, PATENT RIGHTS AND SALES RIGHTS ARE EXPRESSLY RESERVED BY SAMTEC, INC. THIS DOCUMENT SHALL NOT BE DISCLOSED, IN WHOLE OR PART, TO ANY UNAUTHORIZED PERSON OR ENTITY NOR REPRODUCED, TRANSFERRED OR INCORPORATED IN ANY OTHER PROJECT IN ANY MANNER WITHOUT THE EXPRESS WRITTEN CONSENT OF SAMTEC, INC.

MATERIAL: DO NOT SCALE DRAWING SHEET SCALE: 1:5:1

INSULATOR: LCP, UL 94 V0, COLOR: BLACK

CONTACT: COPPER ALLOY

520 PARK EAST BLVD, NEW ALBANY, IN 47150
PHONE: 812-944-6733 FAX: 812-948-5047
e-Mail: info@SAMTEC.com code: 55322

DESCRIPTION:
VERTICAL MINI-POWER SOCKET

DWG. NO.
MPS-XX-X.XX-XX-X-V-XX

BY: BRATCHER 2/15/2007 SHEET 1 OF 2

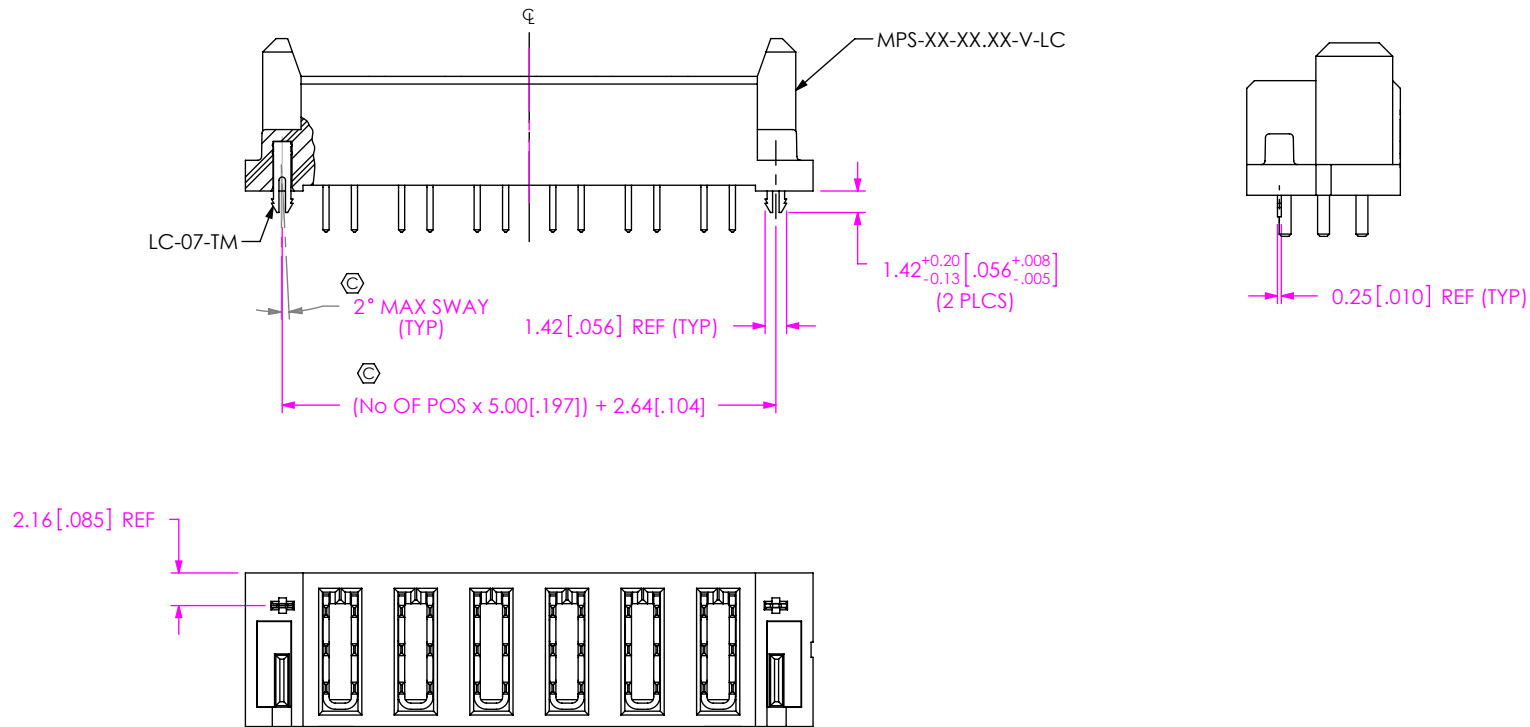

FIG 2
MPS-06-7.70-01-X-V-LC SHOWN
(SAME AS FIG 1, UNLESS OTHERWISE STATED)

TABLE 2		
PLATING	POWER PIN CONTACT AREA	POWER PIN TAIL
-L	10μ" GOLD	MATTE TIN
-T	MATTE TIN	MATTE TIN

PROPRIETARY NOTE
THIS DOCUMENT CONTAINS CONFIDENTIAL AND PROPRIETARY INFORMATION AND ALL DESIGN, MANUFACTURING, REPRODUCTION, USE, PATENT RIGHTS AND SALES RIGHTS ARE EXPRESSLY RESERVED BY SAMTEC, INC. THIS DOCUMENT SHALL NOT BE DISCLOSED, IN WHOLE OR PART, TO ANY UNAUTHORIZED PERSON OR ENTITY NOR REPRODUCED, TRANSFERRED OR INCORPORATED IN ANY OTHER PRODUCT IN ANY MANNER WITHOUT THE EXPRESS WRITTEN CONSENT OF SAMTEC, INC.



520 PARK EAST BLVD, NEW ALBANY, IN 47150
PHONE: 812-944-6733 FAX: 812-948-5047
e-Mail: info@SAMTEC.com code: 55322

DO NOT SCALE DRAWING

SHEET SCALE: 2:1

DESCRIPTION: VERTICAL MINI-POWER SOCKET

DWG. NO. MPS-XX-X.XX-XX-X-V-XX

BY: BRATCHER 2/15/2007 SHEET 2 OF 2