

SPECIFICATION CONTROL DRAWING

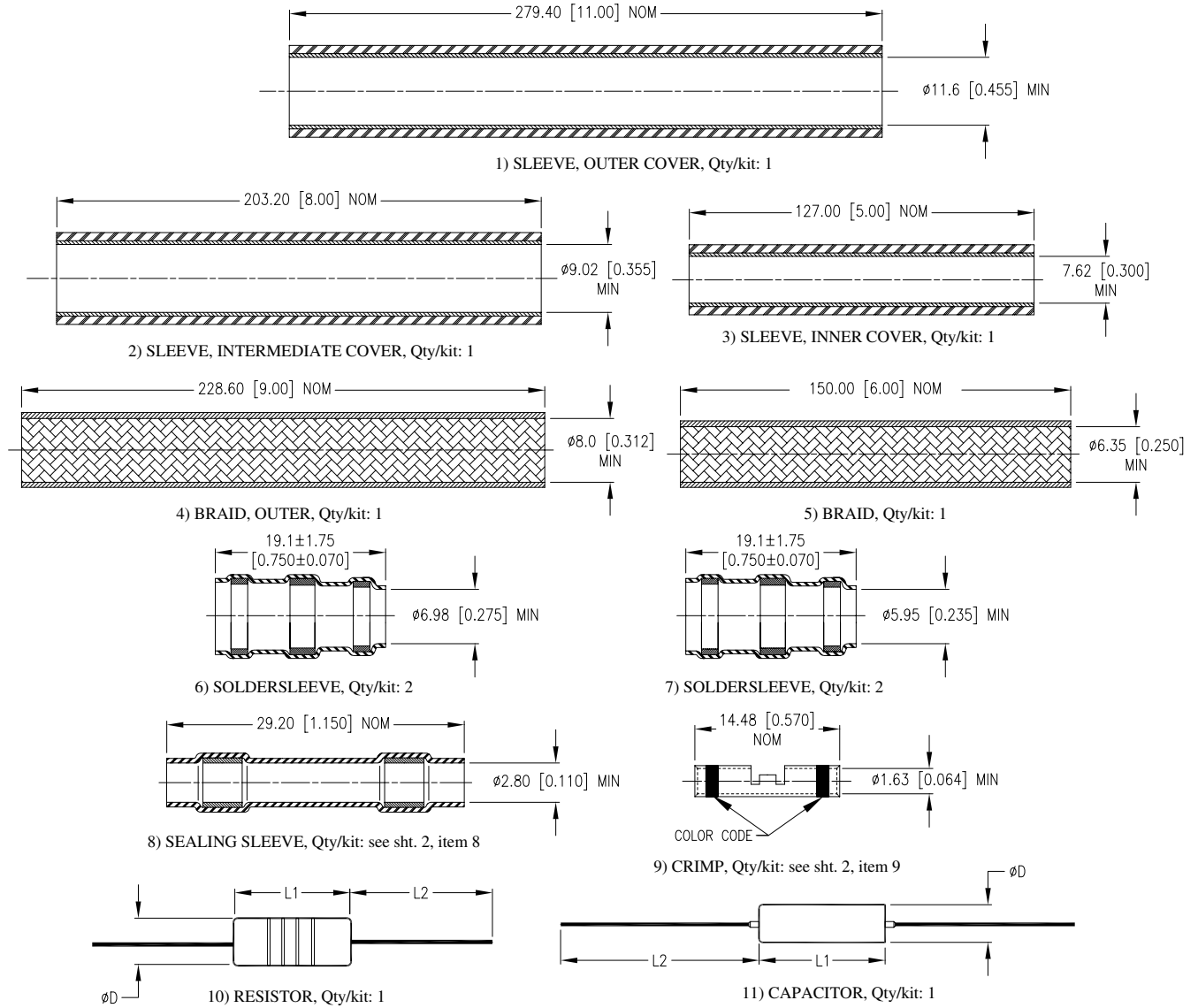

Product Name	Applicable Resistor / Capacitor	Resistor / Capacitor Dimensions		
		L1	L2	ØD
D-150-0328-01	AA5551704560G (resistor)	11.84 [0.466]	20.02 [0.788]	4.57 [0.180]
	RLR32C56R0GR (resistor)	14.27 [0.562]	38.10 [1.500]	4.83 [0.190]
D-150-0328-02	AA5551704152G (resistor)	11.84 [0.466]	20.02 [0.788]	4.57 [0.180]
	RLR32C1520GR (resistor)	14.27 [0.562]	38.10 [1.500]	4.83 [0.190]
D-150-0328-03	M39003/01-7107 (capacitor)	10.72 [0.422]	38.10 [1.50]	3.43 [0.135]
D-150-0328-04	AA5551704222G (resistor)	11.84 [0.466]	20.02 [0.788]	4.57 [0.180]
	RLR32C2201GR (resistor)	14.27 [0.562]	38.10 [1.500]	4.83 [0.190]

D-150-0328-01/-02/-04 kit will have either AA55517 or RLR32C resistor. RLR resistors are alternate equivalent to AA55517.

		Tyco Electronics Corporation 300 Constitution Drive, Menlo Park, CA. 94025, U.S.A.		TITLE: 1 TO 1 SHIELDED TWISTED PAIR, FLEXIBLE SOLDERSHIELD SPLICE KIT, Ni-PLATED CRIMP AND BRAID			
Unless otherwise specified dimensions are in millimeters. [Inches dimensions are shown in brackets]				DOCUMENT NO.: D-150-0328-0X			
TOLERANCES: 0.00 N/A 0.0 N/A 0 N/A	ANGLES: N/A ROUGHNESS IN MICRON	Tyco Electronics reserves the right to amend this drawing at any time. Users should evaluate the suitability of the product for their application.		REV.: B	DATE: 22-June-06		
PREPARED BY: mforonda	DCR NUMBER: D060141	REPLACES: D050435	CAGE CODE : 06090	SCALE: ---	SIZE: A	SHEET: 1 of 4	

SPECIFICATION CONTROL DRAWING

MATERIALS

1. 2. & 3. **OUTER/INNER INSULATION SLEEVE:** Heat-shrinkable, radiation cross-linked polyolefin with hot-melt adhesive inner liner. Color: black.
4. & 5. **BRAID:** Nickel-plated copper alloy per AA59569R36N0250 (Item #4) and AA59569R36N0171 (Item #5).
6. & 7. **SOLDERSLEEVE**
INSULATION SLEEVE: Heat-shrinkable, transparent blue, radiation cross-linked modified polyvinylidene fluoride.
SOLDER PREFORM WITH FLUX AND THERMAL INDICATOR:
SOLDER: TYPE Sn96 per ANSI / J-STD-006.
FLUX: TYPE ROM1 per ANSI / J-STD-004.
THERMAL INDICATOR: Fusible ring, melt point: 232°C, completely melted at 240°C.
MELTABLE RINGS: Environment resistant thermoplastic. Color: blue.
8. **SEALING SLEEVE:** Qty: 2 (D-150-0328-01/-02) or 3 (D-150-0328-03/-04)
INSULATION SLEEVE: Heat-shrinkable, transparent blue, radiation cross-linked modified polyvinylidene fluoride.
SEALING RINGS: Immersion resistant thermoplastic. Color: one clear, one blue.
9. **CRIMP SPLICE:** Nickel-plated copper alloy. Color code: blue, Qty: 2 (D-150-0328-01/02) or 3 (D-150-0328-03/04)
BASE METAL: Copper Alloy 101 or 102 per ASTM B-75.
PLATING: Ductile Nickel per SAE AMS-QQ-N-290.
10. **RESISTOR:** See table for applicable part no. Qty: 1.
11. **CAPACITOR:** See table for applicable part no. Qty: 1.

APPLICATION

1. This kit is used to provide an environmentally protected 1 to 1 splice in shielded twisted pair double shielded cables having nickel-plated primaries and shield, and having an insulation rated for at least 135°C.
2. Temperature range: -55°C to +175°C.

INSTALLATION PROCEDURE

WARNING: Use adequate ventilation and avoid charring or burning during installation. Charring or burning the product will produce fumes that may cause eye, skin, nose and throat irritation.

1. Cable preparation. See figure below.

Tolerances: All lengths ± 0.50 [0.020]. Dimensions typical for cable sides A and B.

- A) For Cable Splice Kits D-150-0328-01 and D-150-0328-02:

- 1) Remove outer cable jacket, outer shield, jacket between shields, and inner shield: 96.52 [3.800].

- 2) Cut 1 primary on each cable: 46.36 [1.825] from cable jacket.

Note: Short primaries on cable side A is to be connected to the long primaries on cable side B.

- 3) Strip primaries: long primaries = 7.62 [0.300]; short primaries = 15.88 [0.625].

Fold-back short primaries to 7.62 [0.300]

- 4) Remove cable jacket: 44.45 [1.750].

- 5) Trim outer shield 9.53 [0.375] from outer cable jacket.

- 6) Remove jacket between shields to expose 9.53 [0.375] of inner shield.

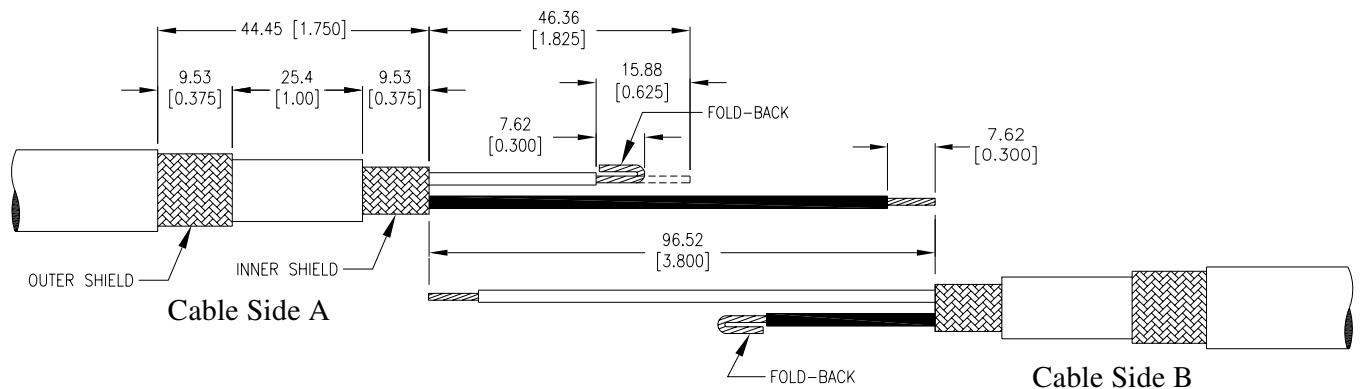

Unless otherwise specified dimensions are in millimeters. [Inches dimensions are shown in brackets]

DOCUMENT NO.:	DCR NUMBER:	CAGE CODE :	REV.:	DATE:	SHEET:
D-150-0328-0X	D060141	06090	B	22-Jun-06	2 of 4

© 2005 – 2006 Tyco Electronics Corporation. All rights reserved.

If this document is printed it becomes uncontrolled. Check for the latest revision.

SPECIFICATION CONTROL DRAWING

B) For Cable Splice Kits D-150-0328-03 and D-150-0328-04:

- 1) Remove outer cable jacket, outer shield, jacket between shields, and inner shield: 75.57 [2.98].
- 2) Cut 1 primary on each cable: 33.66 [1.325] from cable jacket.
- 3) Strip primaries: 15.88 [0.625]. Fold-back primaries to 7.62 [0.300].
- 4) Remove cable jacket: 44.45 [1.750].
- 5) Trim outer shield 9.53 [0.375] from outer cable jacket.
- 6) Remove jacket between shields to expose 9.53 [0.375] of inner shield.
- 7) For filler wire: cut 16.5 [0.650] of the same wire type and strip to 7.62 [0.300].

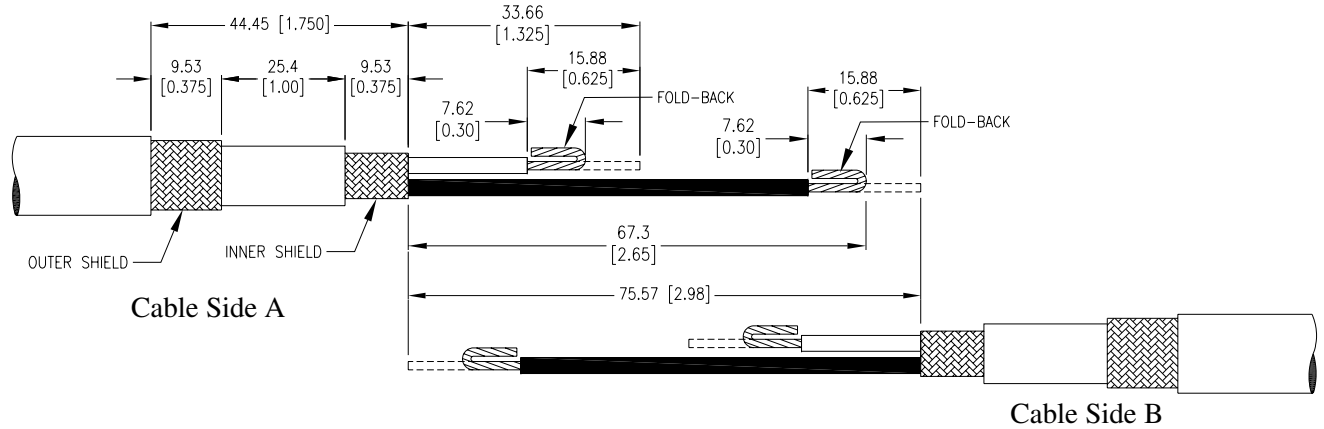

2. Application Equipment

- A) AD-1377 crimp tool or equivalent.
- B) Steinel HL1802E Heat Gun with a SolderSleeve reflector (Setting of 13 – 14).
- C) IR-550 with a SolderSleeve reflector.

3. Assembly Procedure

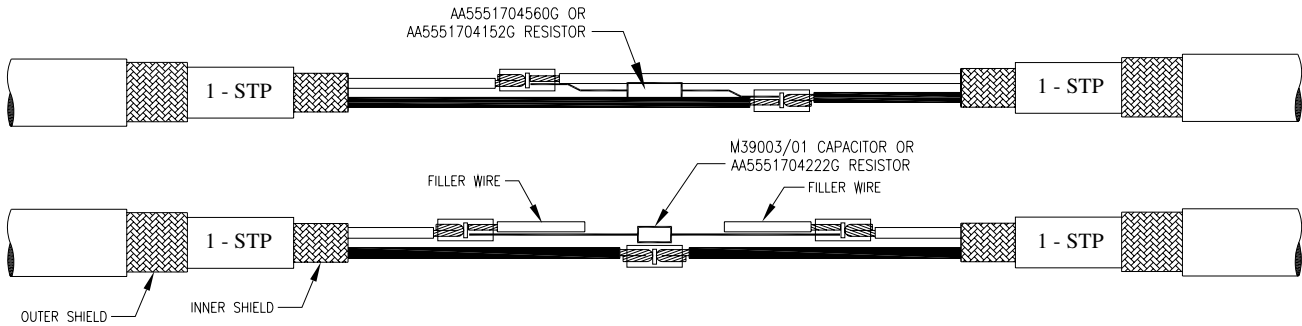

WARNING: The heating tool and the assembly become hot during the installation of the sleeves. To prevent burns, allow tool and the assembly to cool down before handling.

- A) Place the outer Insulation Sleeve on one end of the assembly.
- B) Place the SolderSleeve Item #6 on each cable side.
- C) Place the intermediate Insulation Sleeve on cable side with the outer sleeve.
- D) Place the outer Nickel-plated Braid shield splice onto the other cable assembly.
- E) Place the SolderSleeve Item #7 on each cable side.
- F) Place the inner Insulation Sleeve on cable side with the outer sleeve.
- G) Place the inner Nickel-plated Braid shield splice onto the other cable assembly.

Unless otherwise specified dimensions are in millimeters. [Inches dimensions are shown in brackets]

DOCUMENT NO.:	DCR NUMBER:	CAGE CODE :	REV.:	DATE:	SHEET:
D-150-0328-0X	D060141	06090	B	22-Jun-06	3 of 4

© 2005 – 2006 Tyco Electronics Corporation. All rights reserved.
If this document is printed it becomes uncontrolled. Check for the latest revision.

SPECIFICATION CONTROL DRAWING

H) Primary Conductor Splice:

1. For Cable Splice Kits D-150-0328-01 and D-150-0328-02:
 - a) Place a sealing sleeve onto the shorter lead.
 - b) Crimp primaries into opposite ends of the crimp splices, one primary on one end and the other primary together with one end of the resistor on the other end, using a calibrated Raychem AD-1377 crimp tool or equivalent.
 - c) Center the sealing sleeves over the crimped splices.
 - d) Apply heat to the center of the sleeve until it recovers, and then heat ends until sealing rings melt and flow along wires.
2. For Cable Splice Kits D-150-0328-03 and D-150-0328-04:
 - a) Place a sealing sleeve onto one of the longer lead.
 - b) Crimp primaries into opposite ends of the crimp splices using a calibrated Raychem AD-1377 crimp tool or equivalent.
 - c) Center the sealing sleeves over the crimped splice.
 - d) Apply heat to the center of the sleeve until it recovers, and then heat ends until sealing rings melt and flow along wires.
 - e) Place a sealing sleeve onto the capacitor lead.
 - f) Crimp primaries/capacitor into opposite ends of the crimp splices, one primary on one end and the filler wire with one end of the capacitor on the other end using a calibrated Raychem AD-1377 crimp tool or equivalent.
 - g) Cut filler wire flush to 0.03 in [0.76 mm] from the crimp barrel.
 - h) Center the sealing sleeves over the crimped splice.
 - j) Apply heat to the center of the sleeve until it recovers, and then heat ends until sealing rings melt and flow along wires.

Caution: Do not overheat adjacent wires when using heat gun.
3. Inspection:
 - a) Conductors must be visible at point where they enter the crimp barrel.
 - b) Both indentations of a crimp must be on the crimp barrel.
 - c) Sealing sleeve inserts must have flowed along wire insulation.
 - d) Sleeve must not have discolored to the degree that the crimp barrel cannot be inspected.
 - e) Sleeve must not be cut or split.
4. Position the inner insulation sleeve over the crimped splices, between the exposed cable shield of each side and apply heat to shrink the tubing.

I) Shield Splice:

1. Center the inner Nickel Braid shield splice over the splice and the exposed cable shields. Trim off excess length (as required) so that it will not cover the cable jacket. The jumper braid should overlap the cable inner braid.
2. Position the SolderSleeves (Item #7) over the end of the Nickel Braid and onto the cable jacket.
3. Heat SolderSleeves.
 - a) Apply heat to the center of the sleeve until the solder melts, flows and wets the solder to the cable shield and Nickel Braid. Visual indicator should have completely melted.
 - b) Apply heat to end of sleeve until rings melt and flow along cable jacket.
 - c) Repeat for other end of sleeve.
4. Position the intermediate insulation sleeve and center to overlap the splice equally on each end and apply heat to shrink the tubing.
5. Center the outer Nickel Braid shield splice over the splice and the exposed cable shields. Trim off excess length (as required) so that it will not cover the cable jacket. The jumper braid should overlap the cable outer braid.
6. Position the SolderSleeves (Item #6) over the end of the Nickel Braid and onto the cable jacket.
7. Heat SolderSleeves.
8. Position the outer insulation sleeve and center to overlap the splice equally on each end and apply heat to shrink the tubing.

Unless otherwise specified dimensions are in millimeters. [Inches dimensions are shown in brackets]

DOCUMENT NO.:	DCR NUMBER:	CAGE CODE :	REV.:	DATE:	SHEET:
D-150-0328-0X	D060141	06090	B	22-Jun-06	4 of 4

© 2005 – 2006 Tyco Electronics Corporation. All rights reserved.

If this document is printed it becomes uncontrolled. Check for the latest revision.