

RobotBit - Robot Expansion Board for Micro:bit

SKU 105990110

Robotbit is an excellent robotic expansion board specially designed (for Microbit, by KittenBot team) for primary school students/training institutions/parents/ enthusiasts as a robotic accessory.

Product Feature

It has a powerful ability to drive DC motors, stepper motors, servos, and onboard buzzer and RGB pixels and release all valid IO from microbit, with support the most common electronics module in the market.

It comes with 18650 battery holder, integrated lithium battery boost, charging and protection chip. Support for external power input. Mechanically support for KittenBot robotic chassis and LEGO technical slots.

The powerful drive capability and built-in battery make DIY more convenient and free. We have received unanimous praise from the school teacher training institutions and individual enthusiasts. It is an excellent choice for your robotic projects based on Micro:bit!

Hardware interface

1. 5V external power input (with anti-reverse protection)
2. Power switch
3. Power Indicator
4. Battery Indicator
5. Micro USB charging port
6. 4-channel DC motor / 2-channel stepper motor
7. Jumper for buzzer selection
8. 8 channel IO (corresponding to Micro:bit P0-P2、 P8、 P12-P15)
9. 5V and GND port
10. Buzzer
11. 8 channel servo port
12. I2C interface (expandable I2C module)
13. 18650 battery case
14. Battery protection recovery push button
15. Micro:bit edge connector
16. 4x RGB pixel

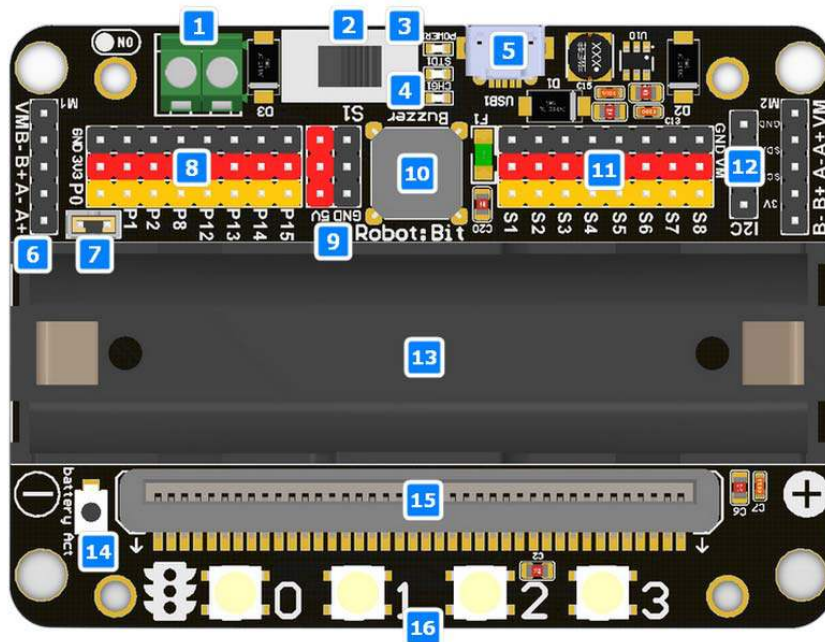

17. Servo driver (PCA9685)
18. 2xDc/Stepper driver (DRV8833)
19. KittenBot robot chassis mounting hole
20. Standard LEGO hole

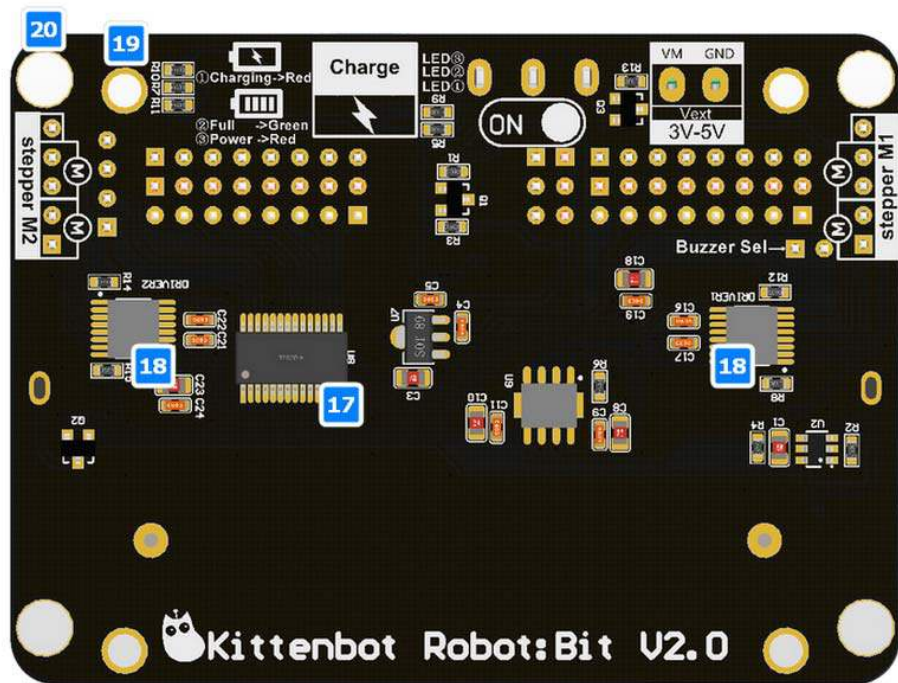

Supported software

Available Coding platform: Kittenblock(based on Scratch3.0) or Makecode and python(Mu editor in microbit mode)

MakeCode from Microsoft

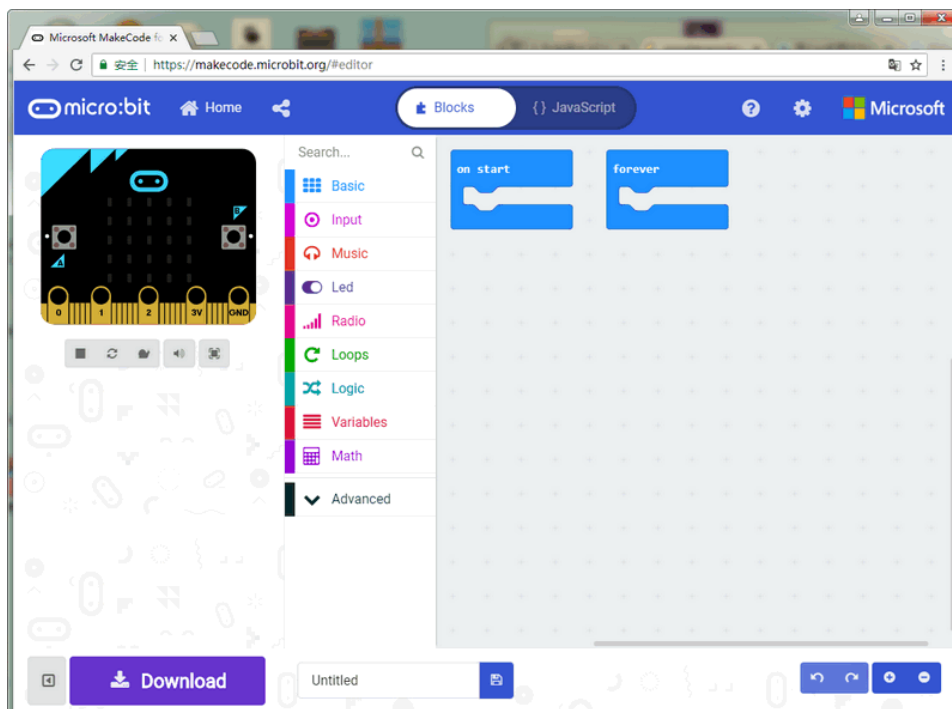

KittenBlock (Developed by Kittenbot Team based on Scratch 3.0)

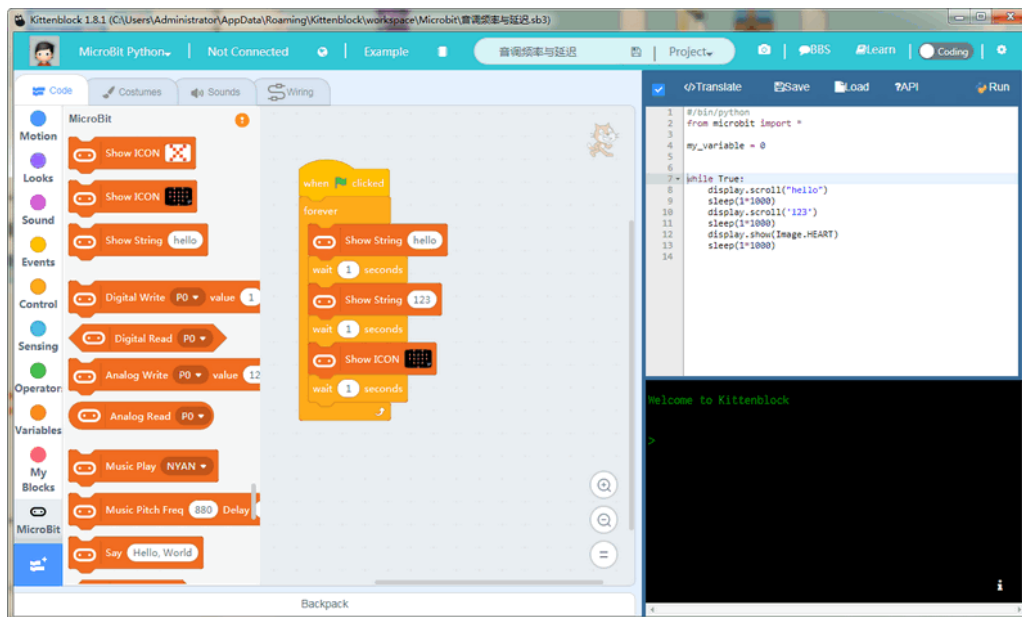

Python

If you're used to code programming and want to get started by microbit python you have two options, directly Mu Editor or kittenblock in micropython editor mode.

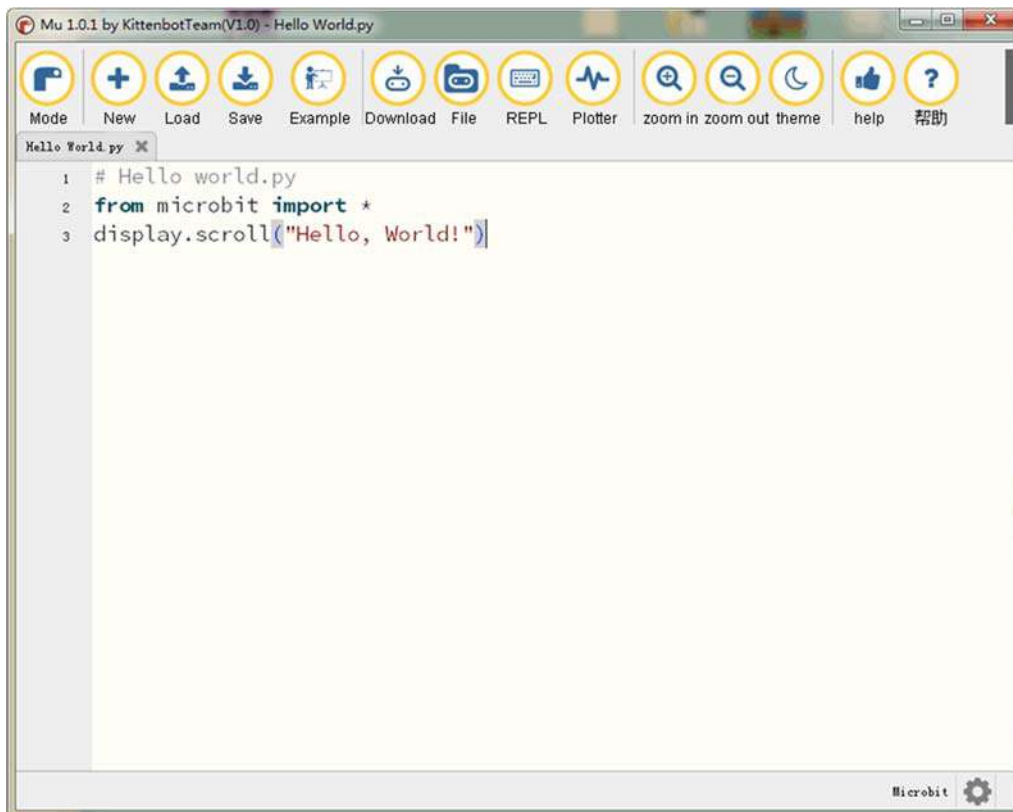

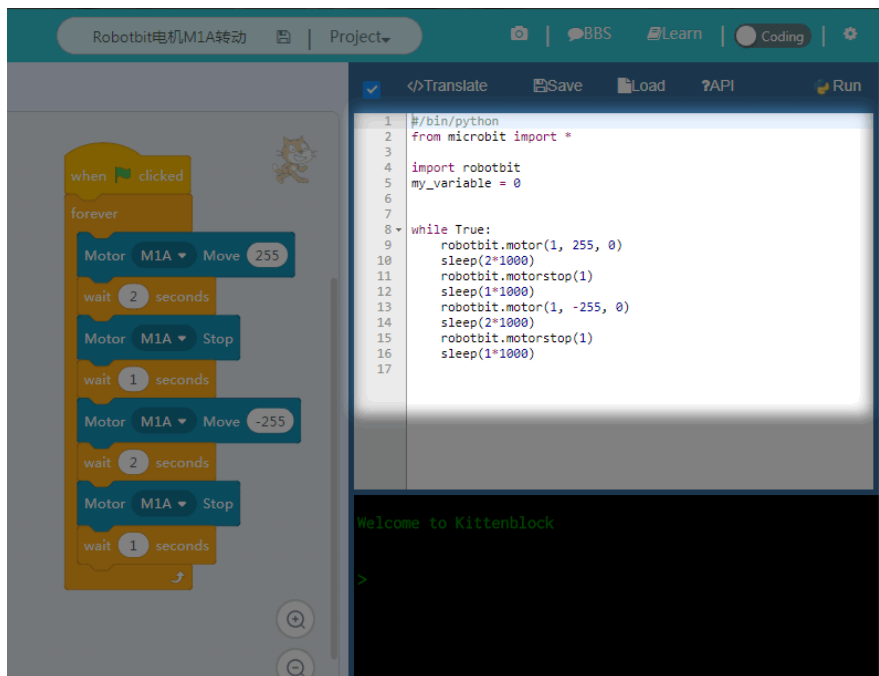

The above detailed tutorial can be found from our learn website for self-learning. If you encounter problems during the learning process, you are welcome to get us at our bbs or slack channel.

Makecode Extension

In makecode add extension panel directly search Robotbit. In our offline version of makecode, you may find Robotbit in the default list and other useful extensions.

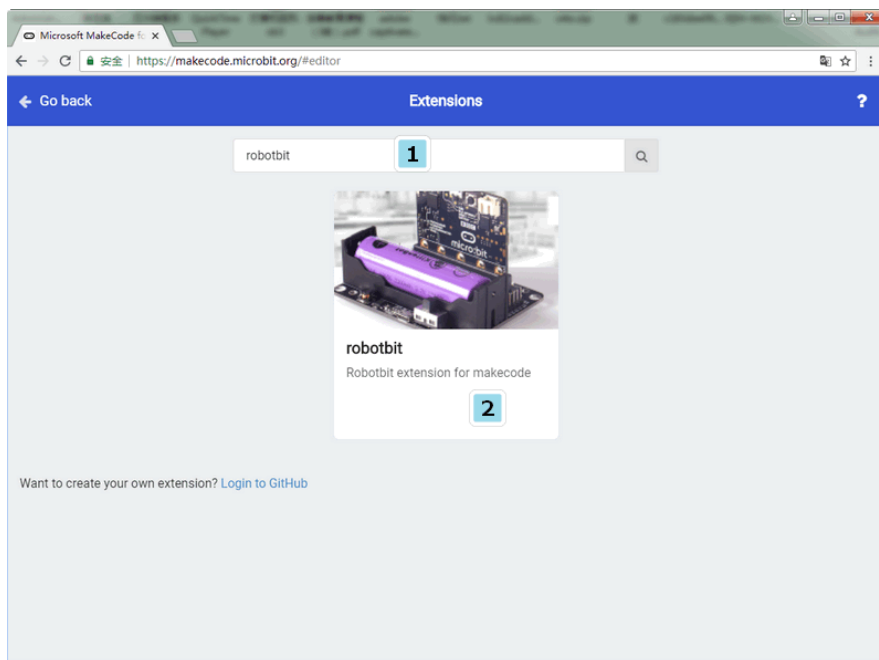

Robotbit Detailed description

18650 battery case

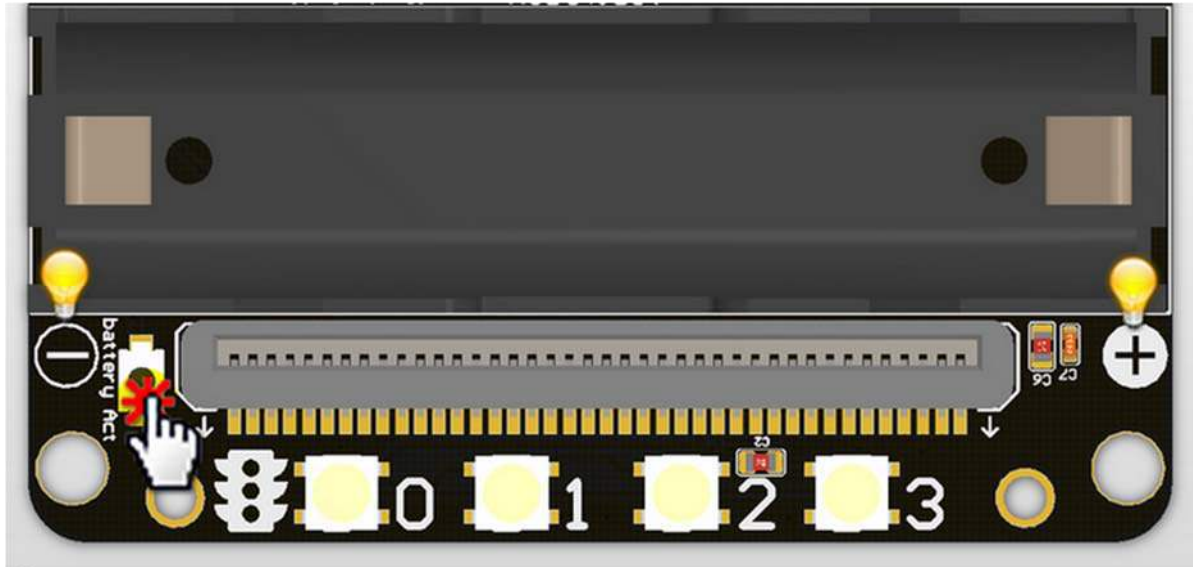

Once you got your RobotBit extension board please first install a 18650 battery, pay attention to the positive and negative pole (even we have anti-reverse protection). You have to activate the power management system by pressing the Battery Act push button. Each time you switch a battery cell or let the power management go into protection mode (over current or over discharge), you have to redo this step.

18650 Power switch

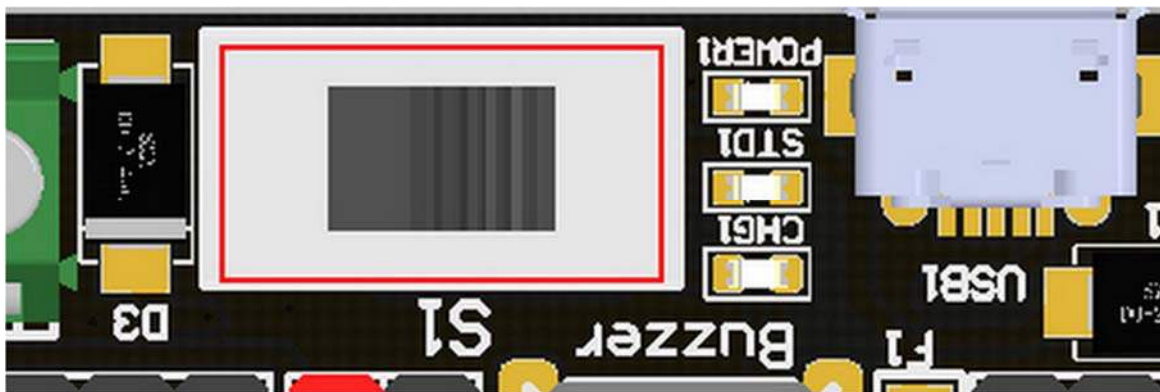

Turn on the switch (in the direction of green terminal input), will provide onboard 3.3V 5V and VM(motors and servos directly driver by battery cell)

Micro USB charger port

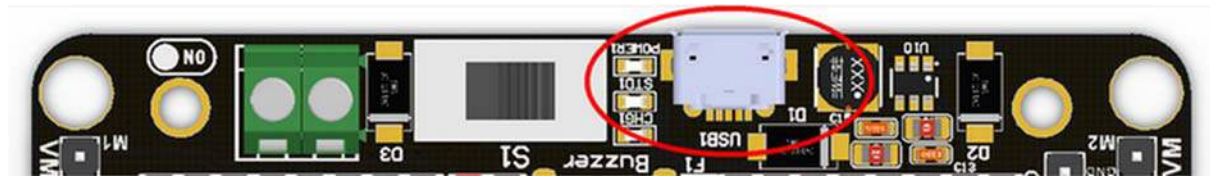

Only for charging and not for download! Computer USB host port or any other mobile phone charger which may output 1A or larger should be fine and may take about 2.5 hours to fully charge a 18650 cell. it will automatically cut off once full, no need to worry about overshoot.

Power and battery indicator

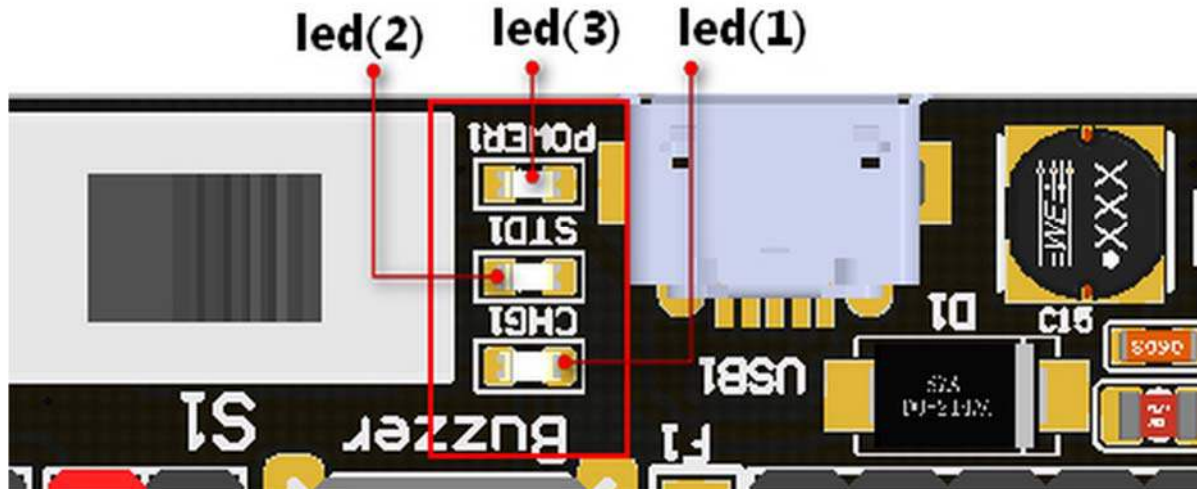

Led(3) is the power indicator, will be always on after switch is turned on. Led(1) is charging indicator, will be on while charging and Led(2) be on once fully charged.

Micro:bit stand edge connector

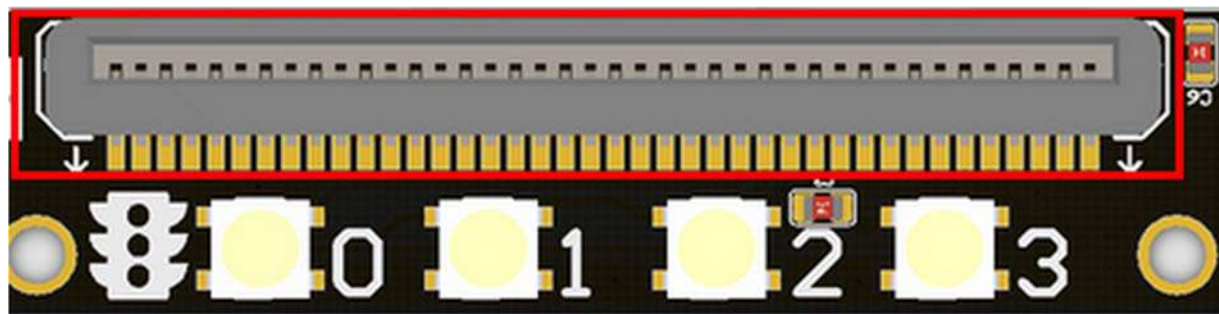

For installing Microbit mainboard. Please install Microbit with led matrix and RGB led in the same direction.

4x RGB neopixel

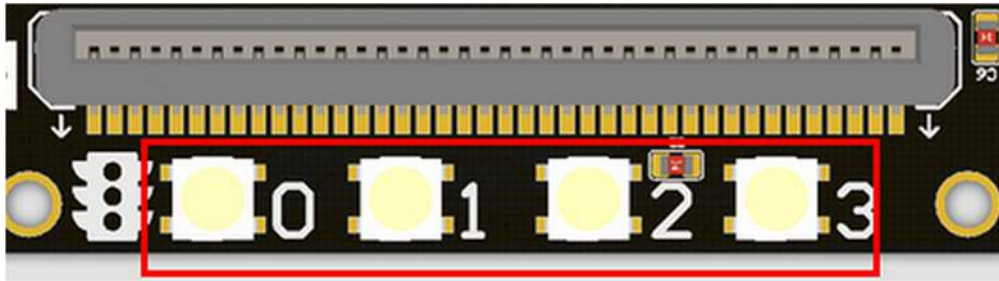

The robotbit extension for makecode has integrated neopixel support. Neopixel array connect to P16 of microbit.

8 channel servo connector

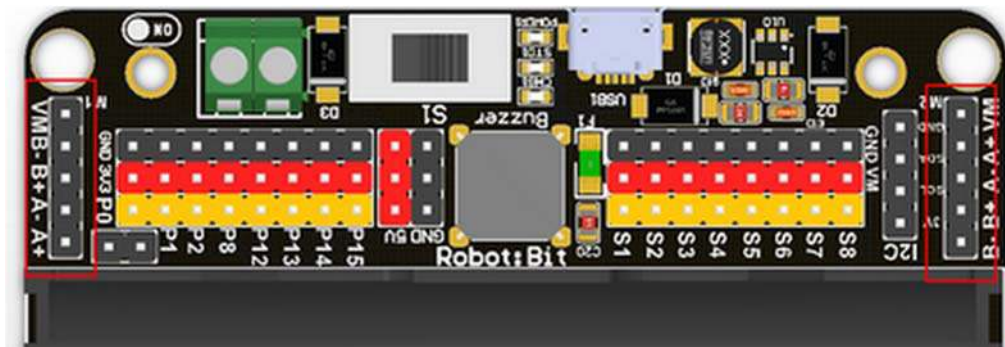

Servos are driven by an extension chip (PCA9685) with the power source from battery or external input. The extension chip communicates with Microbit via the i2c interface, so these S1~S8 interfaces can only be used for pulse output not as common IO. With onboard 18650 battery cell, it may drive eight 9g hobby servo (with maximum current less than 2A). If you plan to use larger servos like MG995 please use an external power resource connect to the green slot (the input still 5V). Robotbit extension has built-in blocks for controlling servos.

4 channel DC motors / 2 channel 28BYJ micro steppers

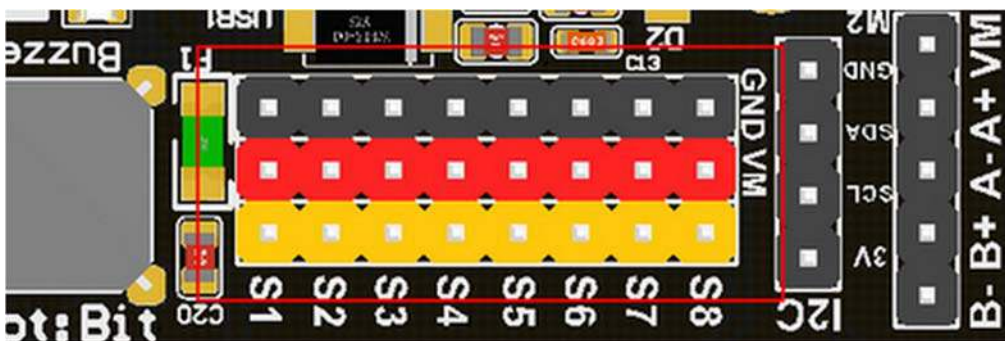

Robotbit extension has also built-in blocks for DC motors and steppers. With onboard cell you may drive 4x TT motors or 2x 28BYJ steppers, or a mixture of these. Keep in mind that VM may output 2A to motors and servos. If you use external source please keep the input around 5V or less, a high voltage external input may damage the 5V boost circuit.

Buzzer and the selection jumper

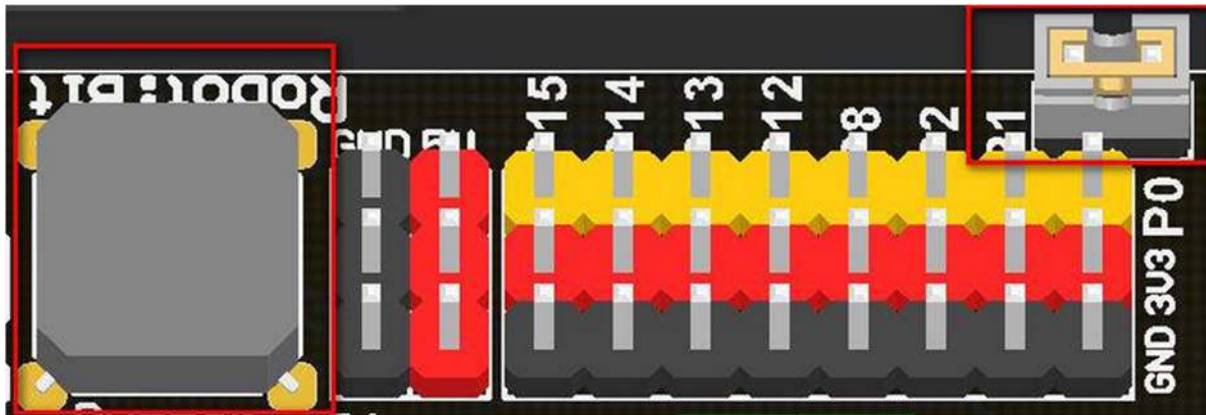

The buzzer jumper cap is plugged in by default, and the corresponding buzzer is connected to the Micro:bit P0 port. If you need P0 for other purposes please unplug the jumper. The buzzer associate to music blocks in makecode.

Micro:bit IO

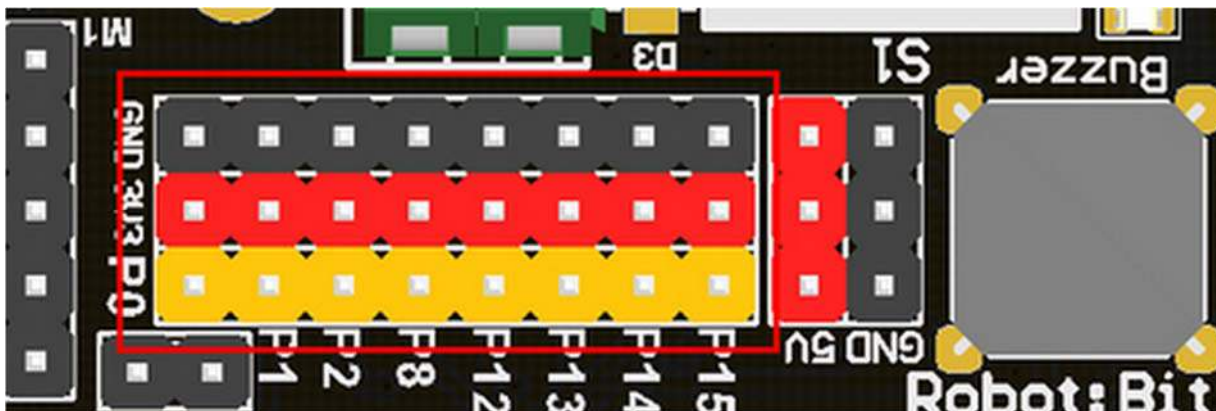

We have released P0-P2, P8, P12-P15 from Microbit to Robotbit for common IO usage. P0~P2 has analog read/write support, others may act as digital IOs. You may connect commonly modules for Arduino to Robotbit, there is also 5V output in case your module only support 5V power input. Please note that Microbit IO signal level is 3.3V.

I2C Interface

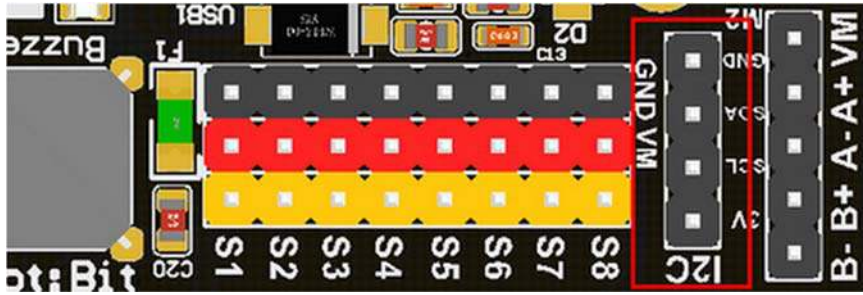

Expandable I2C module, can only be used to plug in I2C module.

2PIN External Power Input

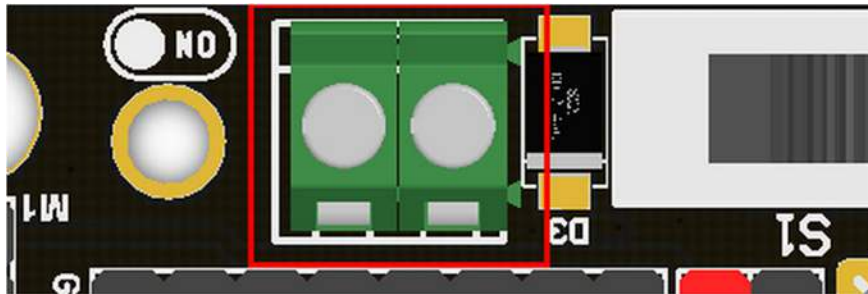

Although there is anti-reverse protection, but still pay attention while wiring. The positive and negative silkink of this interface is on the back of Robotbit. You can only input 5V or less into this port. If you have a higher voltage source you may need a LDO or DC-DC module to buck the voltage down.

Product Parameters

Dimensions: 78mm x 57mm x 23mm

PCB Thickness: 1.5mm

Small mechanical hole: 3.0mm

Big mechanical hole: 4.8mm

Net weight (without packaging): 37.5g

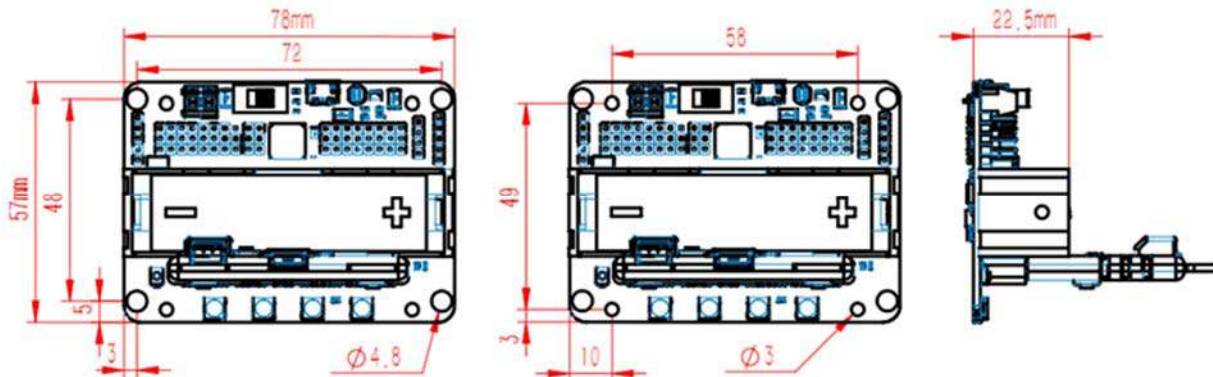

Functional parameters

18650 battery voltage: 3.7V

USB input voltage: 5V

VM pin max output: 1A (with onboard battery)

External Voltage Input (the green terminal): 5V (only supports 5V input, do not connect over 5V, maximum current supports 3A)

Part List

RobotbitV2.0 x1

ECCN/HTS

ECCN	EAR99
HSCODE	8517709000

Robotbit Quick start

Put the 18650 battery on the Robotbit, pay attention to the positive and negative pole.

Plug the Microbit into the Robotbit and pay attention to the plugging direction.

Click the battery activation button

Turn on the 18650 battery switch

Open the makecode editor (<http://makecode.microbit.org>) and press add package.

1

Jump to the makecode programming website

<https://makecode.microbit.org>

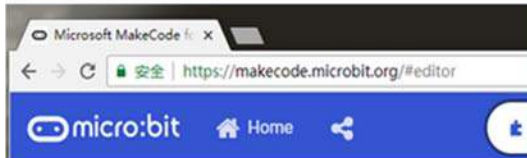

2



Search robotbit

3

Follow the steps,
Enter robotbit and click Search
then select the plugin package that appears.

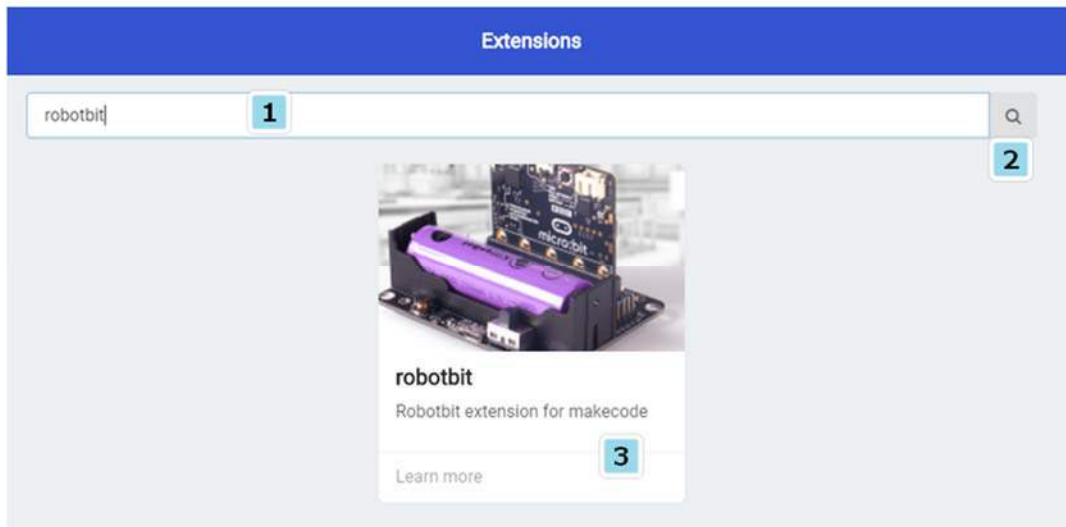

4

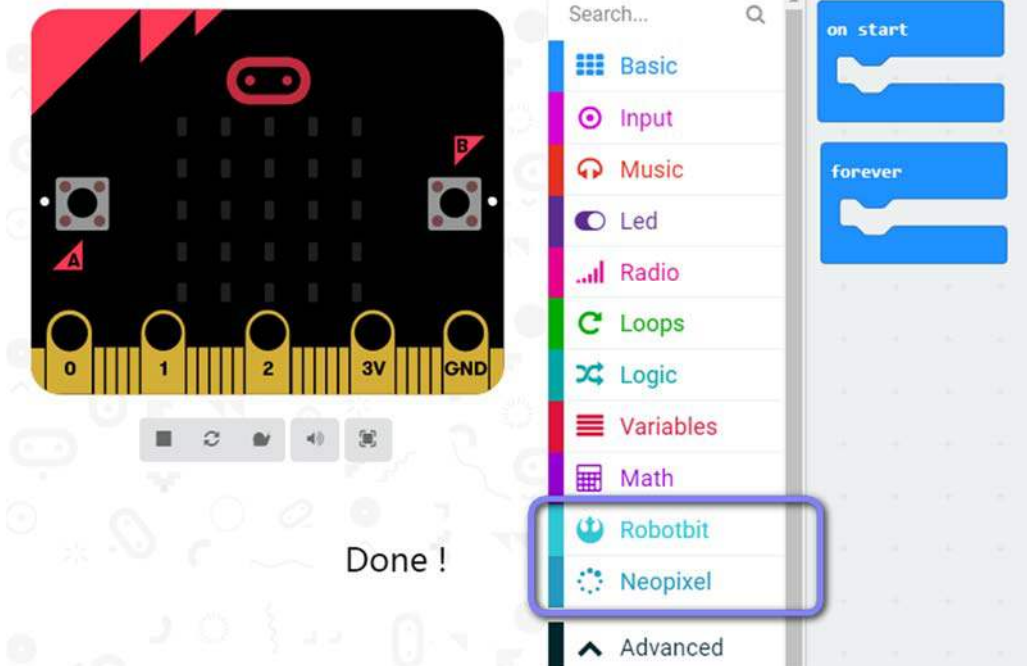

Drag some of the robotbit blocks out to workspace, remember to connect the corresponding motor servos, etc.

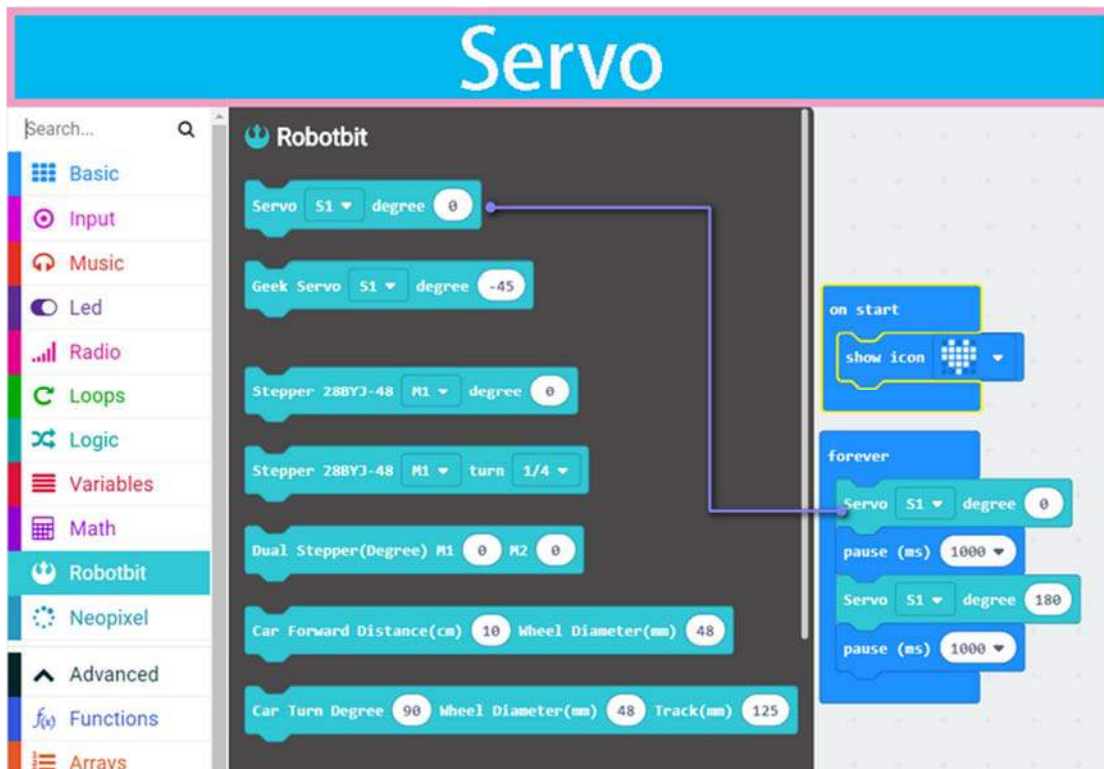

Stepper motor

Search...

- Basic
- Input
- Music
- Led
- Radio
- Loops
- Logic
- Variables
- Math
- Robotbit
- Neopixel
- Advanced
- Functions
- Arrays

Robotbit

Servo S1 degree 0

Geek Servo S1 degree -45

Stepper 28BYJ-48 M1 degree 0

Stepper 28BYJ-48 M1 turn 1/4

Dual Stepper(Degree) M1 0 M2 0

Car Forward Distance(cm) 10 Wheel Diameter(mm) 48

Car Turn Degree 90 Wheel Diameter(mm) 48 Track(mm) 125

on start

show icon

forever

Stepper 28BYJ-48 M1 degree 0

pause (ms) 500

Stepper 28BYJ-48 M1 turn 1

pause (ms) 500

DC Motor

Search...

- Basic
- Input
- Music
- Led
- Radio
- Loops
- Logic
- Variables
- Math
- Robotbit
- Neopixel
- Advanced
- Functions
- Arrays

Car Turn Degree 90 Wheel Diameter(mm) 48 Track(mm) 125

Motor M1A speed 0

Motor M1A speed 150

Motor M1A speed 150

Motor M1A speed 150 delay 1 s

Motor Stop M1A

Motor Stop All

on start

show icon

forever

Motor M1A speed -255

pause (ms) 1000

Motor Stop All

pause (ms) 1000

Motor M1A speed 255

pause (ms) 1000

RGB

The image shows a Scratch code editor with a blue header titled "RGB". On the left, a sidebar lists various categories: Loops, Logic, Variables, Math, Robotbit, Neopixel, Advanced, Functions, Arrays, Text, Game, Images, Pins, Serial, and Control. The main workspace contains a script starting with a "speed" block set to 150, followed by a "Motor" block (M1A) with speed 150 and a 1-second delay, then a "Motor Stop" block (M1A), and a "Motor Stop All" block. Below these are "Matrix Draw X" (0, Y 0), "Matrix Clear", and "Ultrasonic pin" (P0). A "forever" loop is highlighted in yellow and contains three "RGB show color" blocks (red, blue, yellow) each followed by a "pause (ms)" block set to 1000. A blue line connects the "Neopixel" category in the sidebar to the "RGB show color" blocks in the script.

Buzzer

The image shows a Scratch code editor with a blue header titled "Buzzer". On the left, a sidebar lists various categories: Basic, Input, Music, Led, Radio, Loops, Logic, Variables, Math, Robotbit, Neopixel, Advanced, and Functions. The "Music" category is highlighted in red. The main workspace contains a script with several music-related blocks: "play tone" (Middle C for 1 beat), "ring tone (Hz)" (Middle C), "rest(ms)" (1 beat), "start melody" (dadadum, repeating once), and "music on" (melody note played). Below these are "Middle C", "1 beat", and "tempo (bpm)" blocks. A "forever" loop is highlighted in yellow and contains two "play tone" blocks (Middle C for 1 beat and High G for 1/2 beat) each followed by a "pause (ms)" block set to 500.

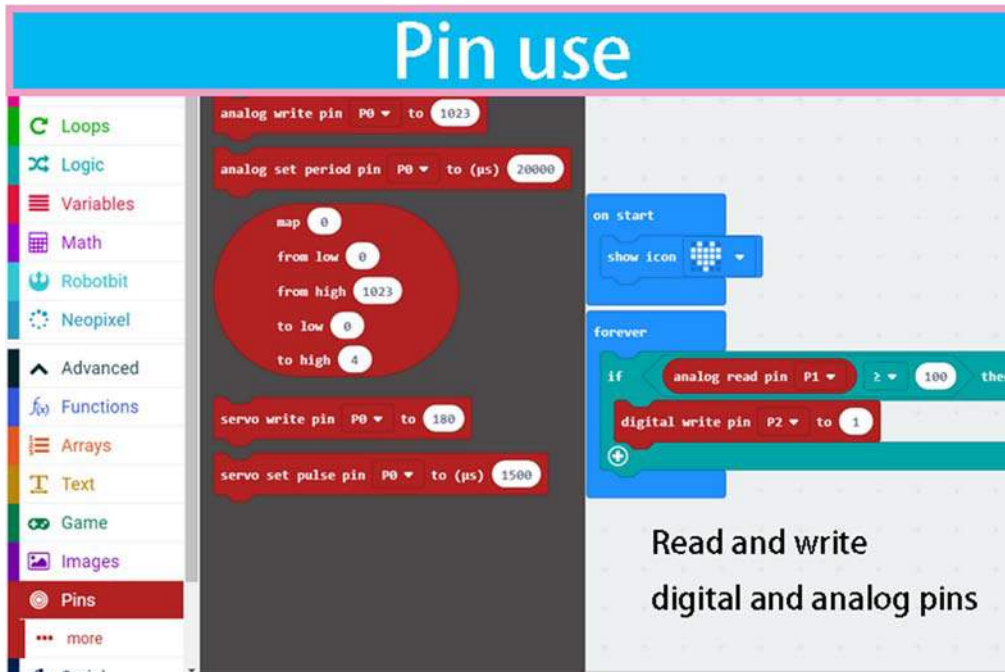

Before downloading, remember to connect to Microbit's with a micro usb cable and click the download button.

After click download button, a file save box will prompt, please choose to save it to the Microbit removable disk.

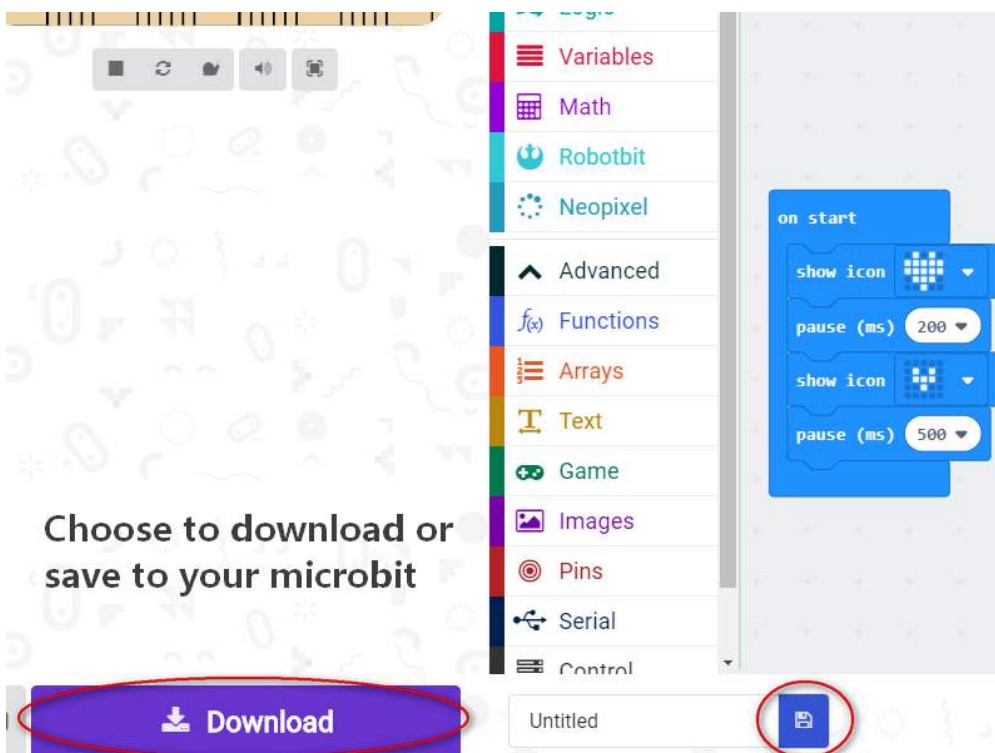

the final effect of the code block in the diagram above

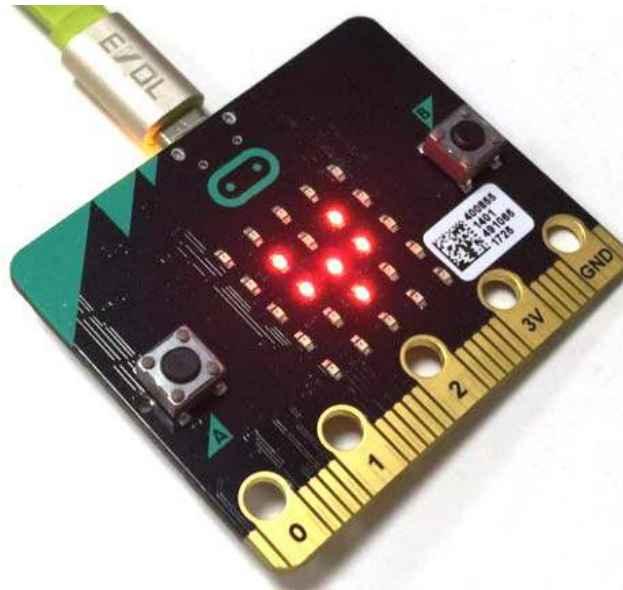

F&Q

The battery is plugged in, there is no response after turn on switch?

Check if the battery activation button has been pressed? Check if the battery is positive or negative? Check if the battery has power?

What is the battery activation button used for?

In the case of overcurrent, or short circuit, or switch battery cell, the battery protection chip will protect the the circuit. Click the battery activation button to resume normal working mode.

Plugged in usb cable and I can't find Microbit

The usb on the robotbit can only be used for charging. It can't be used to download the program. It is plugged into the usb port of the robotbit. The computer will not respond.

Will it smoke if I insert battery inverse ?

No, the robotbit design is anti-reverse protect in consideration of general miss operations. Inversely plug in will just not output power.

Will Microbit damage if plug in face back?

No, it will just refuse to work.

P0 pin control does not respond? Is it broken?

You need to unplug the buzzer selection jumper to use P0 as common IO.

Where is the rest of Microbit's IOs ?

Nearly 20 programmable IO ports on the Microbit, but many have been multiplexed with the dot matrix buttons on the board. Considering the inconvenience caused by multiplexing, beginners are likely to confuse on these. We have bridge 8 IO with no conflict to matrix or buttons to Robotbit, it should be enough for most diy projects. If you need all IO from microbit please choose IOBit from kittenbot team.

Can the servo interface act as common IO?

No, the servo s1-s8 is extended with a special servo drive chip and can only be used for servo drive.

What is the use of the VM on the motor interface?

The power source for 4-phase 5-wire stepper motor like 28BYJ. Usually, the VM is not used for the DC motor, and the DC motor only needs to connect A+A- or B+B-.

Can the board be placed on a metal surface or in a humid environment?

No, it will be short-circuited, pay attention to insulation

What is the voltage input for the green external power supply? What will happens with a higher voltage input?

Can only be connected to 5V, above 5V will damage the board, the current is recommended 2~3A, which means that the maximum current supported by the board is 3A

I did follow the tutorial, not results

If the test results are not corresponding, first check your wiring and procedures, some small place in general is missing, please double check.

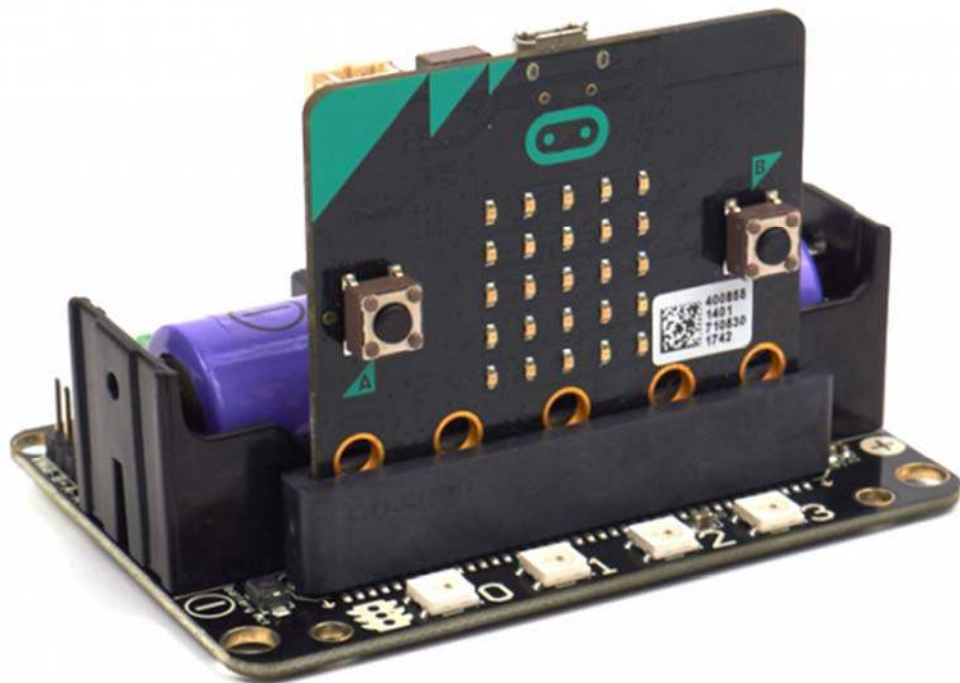

<https://www.seeedstudio.com/RobotBit-Robot-Expansion-Board-for-Micro-bit.html> //3-25-19