

REVISIONS			
REV.	DESCRIPTION	DATE	APPROVED
A	INITIAL RELEASE	03/13/18	D.N.

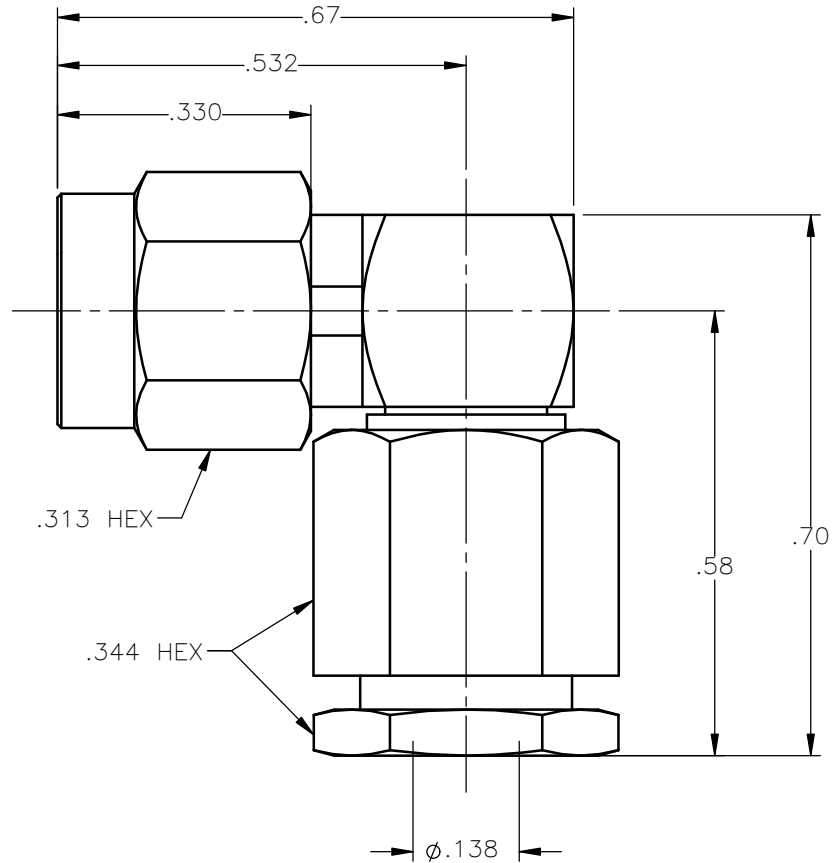

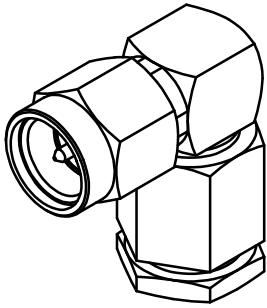

NOTES:

MATERIALS:

1. BODIES & COUPLING NUT = STAINLESS STEEL PER ASTM A582, ALLOY 303, CONDITION "A".
2. INSULATORS = VIRGIN WHITE TEFLON PER ASTM D1710, GRADE 1, TYPE I, CLASS "B".
3. CONTACT & RETAINING RING = BERYLLIUM COPPER PER ASTM B196, ALLOY C17300, TEMPER TD04.
4. GASKET = SILICONE RUBBER PER ZZ-R-765, CLASS 2B, GRADE 65-75.
5. ALL OTHER METAL PARTS = BRASS PER ASTM B16, ALLOY C36000, TEMPER H02.

FINISHES:

1. BODIES = GOLD PLATE PER ASTM B488-11, TYPE II, 30 μ in MIN, GRADE C, OVER 50 TO 100 μ in STRESS FREE NICKEL PER AMS-QQ-N-290.
2. COUPLING NUT = PASSIVATE PER SAE-AMS-2700
3. CONTACT = GOLD PLATE PER ASTM B488-11, TYPE II, 50 μ in MIN, GRADE C, OVER 100 TO 200 μ in STRESS FREE SULFAMATE NICKEL PER AMS-QQ-N-290.
4. ALL OTHER METAL PARTS = GOLD PLATE PER ASTM B488-11, TYPE II, 30 μ in MIN, GRADE C OVER 100 TO 200 μ in COPPER STRIKE PER AMS 2418.

UNLESS OTHERWISE SPECIFIED DIMENSIONS ARE IN INCHES TOLERANCES ON	DWN:	DATE		Property of Radiall			
	D.N.	03/14/18		This document cannot be reproduced or communicated to a third party without prior written permission of RADIALL.			
DECIMAL	ANGLE	CHKD:	DATE	SMA RIGHT ANGLE PLUG CLAMP TYPE FOR RG-316DS & SIMILAR CABLES			
		C.E.	03/14/18				
		APVD:	DATE	SIZE	FSCM NO.	DWG NO.	REV
		J.M.	03/14/18	A	19505	9243-1553-019	A
REFERENCE:	MATERIALS & FINISHES:		SCALE	THIRD ANGLE PROJECTION		SHEET 1 OF 1	
ORIGINATED: D.N. DATE: 03/14/18	SEE NOTES		4:1				

9243-1553-019