

Smallest 60mA 3-Channel Charge Pump White LED Driver with Low Dropout Current Source

General Description

The RT9363 is a high efficiency and cost effective charge pump white LED driver. It supports up to 3 white LEDs with regulated constant current for uniform intensity. The RT9363 maintains the highest efficiency by utilizing a x1/x2 charge pump and low dropout current regulators.

User can easily configure each LED current up to 20mA by a pulse dimming control. The dimming of white LEDs current can be achieved by applying a pulse signal to the EN pin. There are totally 16 steps of current could be set by users.

The operating voltage range is 2.8V to 5.0V. Internal soft start circuitry effectively reduces the inrush current while both start-up and mode transition. RT9363 also provides comprehensive protections such as short circuit protection. The load is disconnected from VIN while shutdown and the shutdown current is less than 10 μ A.

RT9363 is available in a TSOT-23-8 package (1.0mm max height).

Ordering Information

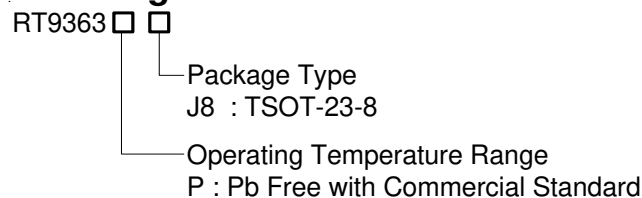

Note :

RichTek Pb-free products are :

- ▶RoHS compliant and compatible with the current requirements of IPC/JEDEC J-STD-020.
- ▶Suitable for use in SnPb or Pb-free soldering processes.
- ▶100% matte tin (Sn) plating.

Marking Information

For marking information, contact our sales representative directly or through a RichTek distributor located in your area, otherwise visit our website for detail.

Features

- Very High Efficiency Over 80% of Battery Life
- Support up to 3 White LEDs
- Support up to 60mA Output Current
- 5% Typical LED Current Matching
- Soft Start Function
- Short Circuit Protection Function
- Auto Charge Pump Mode Selection
- 1MHz Fixed Frequency Oscillator
- Output Over Voltage Protection
- 16-Step Brightness Control
- Low Input Noise and EMI
- RoHS Compliant and 100% Lead (Pb)-Free

Applications

- Mobile Phone, DSC, MP3
- White LED Backlighting
- LCD Display Supply

Pin Configurations

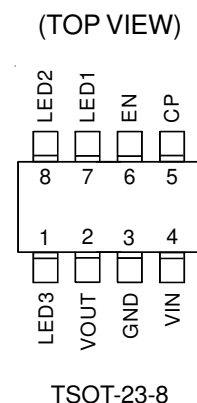

Note : There is no pin1 indicator on top mark for TSOT-23-8 type, and pin 1 will be lower left pin when reading top mark from left to right.

Typical Application Circuit

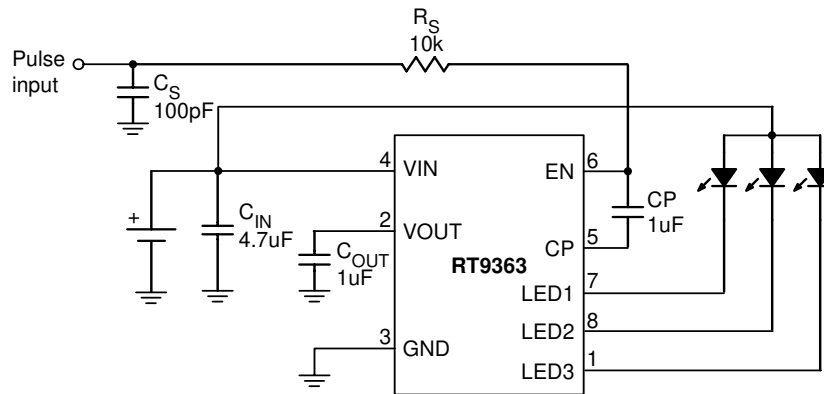

Figure 1. For 3-WLEDs Application Circuit

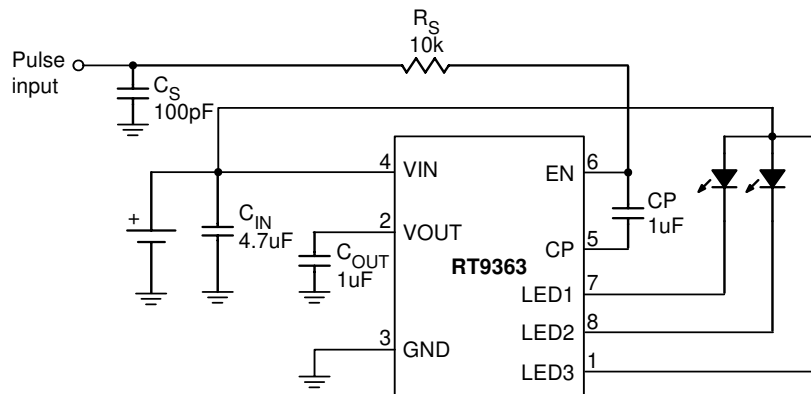
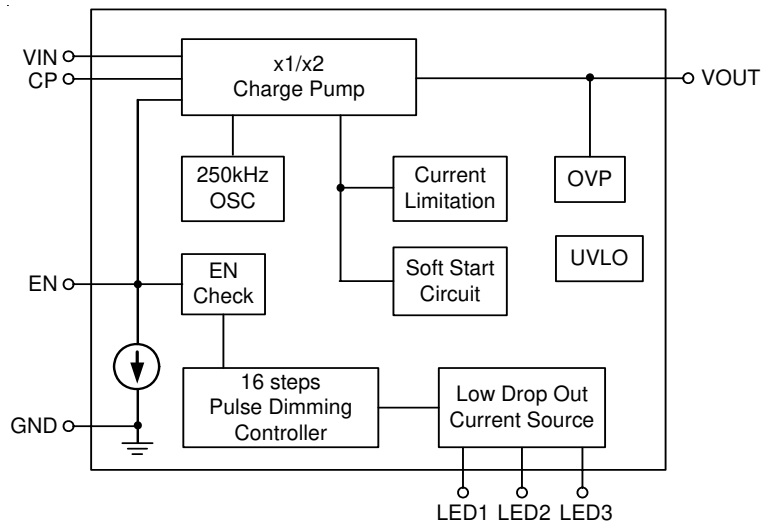

Figure 2. For 2-WLEDs Application Circuit

Functional Pin Description

Pin Number	Pin Name	Pin Function
1	LED3	Current Sink for LED3. (If not in use, this pin must be connected to V_{IN})
2	VOUT	Output Voltage Source for LED1~3.
3	GND	Power Ground.
4	VIN	Input Voltage.
5	CP	Positive Terminal of Bucket Capacitor.
6	EN	Active High Enable. And connects 10k resistor to GPIO pin of MCU.
7	LED1	Current Sink for LED1. (If not in use, this pin must be connected to V_{IN})
8	LED2	Current Sink for LED2. (If not in use, this pin must be connected to V_{IN})

Function Block Diagram



Absolute Maximum Ratings (Note 1)

- Supply Input Voltage ----- -0.3V to 6V
- Other I/O Pin Voltages ----- -0.3V to 6V
- Power Dissipation, P_D @ $T_A = 25^\circ\text{C}$
 TSOT-23-8 ----- 0.455W
- Package Thermal Resistance (Note 4)
 TSOT-23-8, θ_{JA} ----- 220°C/W
- Lead Temperature (Soldering, 10 sec.) ----- 260°C
- Junction Temperature ----- 125°C
- Storage Temperature Range ----- -65°C to 150°C
- ESD Susceptibility (Note 2)
 HBM (Human Body Mode) ----- 2kV
 MM (Machine Mode) ----- 200V

Recommended Operating Conditions (Note 3)

- Junction Temperature Range ----- -40°C to 125°C
- Ambient Temperature Range ----- -40°C to 85°C

Electrical Characteristics

($V_{IN} = 3.7\text{V}$, $T_A = 25^\circ\text{C}$, unless otherwise specified)

Parameter	Symbol	Test Condition	Min	Typ	Max	Units
Input Supply Voltage	V_{IN}		2.8	--	5.0	V
Under Voltage Lockout Threshold		V_{IN} Rising or Falling	--	2.2	--	V
Under Voltage Lockout Hysteresis			--	100	--	mV
LEDs Current	I_{LED}	100% Setting	--	20	--	mA
Shutdown Current	I_{SHDN}	$EN = 0\text{V}$, $V_{IN} = 3.6\text{V}$	--	3	10	μA
Quiescent Current	I_Q	$EN = \text{High}$, $V_{IN} = 3.6\text{V}$, No Load (V_{IN} connect to LED1~3)	--	1	--	mA
I_{LED} Accuracy	$I_{LED-ERR}$	100% Setting, $I_{LED1\sim3}$	-8	--	+8	%
Current Matching	$I_{LED-LED-ERR}$	100% Setting, $I_{LED1\sim3}$	-5	--	+5	%
x1 mode to x2 mode Transition Voltage (V_{IN} Falling)	$V_{TRANS1X}$	$V_{LED} = 3.4\text{V}$, $I_{OUT} = 45\text{mA}$ $I_{LED1} = I_{LED2} = I_{LED3} = 15\text{mA}$	--	3.6	--	V
Oscillator Frequency	F_{OSC}	$V_{IN} = 3.0\text{V}$ (x2 mode)	--	1.0	--	MHz
Inrush Current	I_{INRUSH}		--	--	250	mA
EN Threshold Voltage	Logic-High	V_{IH}	1.5	--	--	V
	Logic-Low	V_{IL}	--	--	0.25	V
EN Current	Logic-High	I_{IH}	--	200	--	μA
	Logic-Low	I_{IL}	--	0.1	10	μA
EN Low to Shutdown Delay	T_{SHDN}		--	--	2	ms
EN Low Time for Dimming	T_{LO}		0.1	--	0.3	ms

(To be continued)

Parameter	Symbol	Test Condition	Min	Typ	Max	Units
EN High Time for Dimming	T _{HI}		0.1	--	0.3	ms
EN High Time for Holding	T _{HO}	(Note 5)	0.1	--	--	ms
Over Voltage Protection	V _{OVP}	Open circuit at any LED that is programmed to be in the on state	--	5.5	--	V

Note 1. Stresses listed as the above "Absolute Maximum Ratings" may cause permanent damage to the device. These are for stress ratings. Functional operation of the device at these or any other conditions beyond those indicated in the operational sections of the specifications is not implied. Exposure to absolute maximum rating conditions for extended periods may remain possibility to affect device reliability.

Note 2. Devices are ESD sensitive. Handling precaution recommended.

Note 3. The device is not guaranteed to function outside its operating conditions.

Note 4. θ_{JA} is measured in the natural convection at $T_A = 25^\circ\text{C}$ on a low effective thermal conductivity test board of JEDEC 51-3 thermal measurement standard.

Note 5. EN High time after the dimming sequence has being completed.

Typical Operating Characteristics

Efficiency vs. Input Voltage

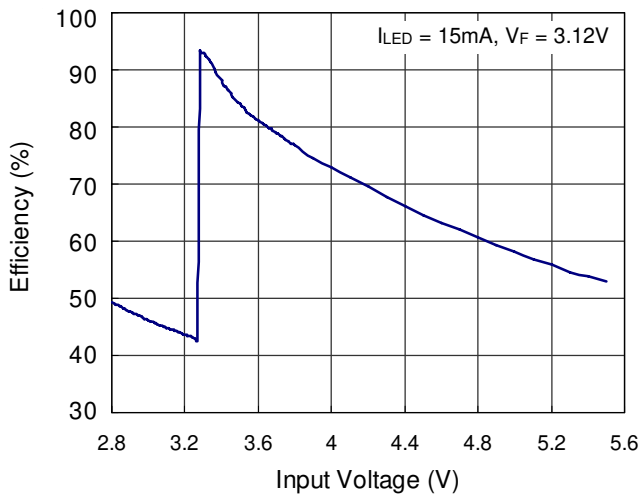

Efficiency vs. Input Voltage

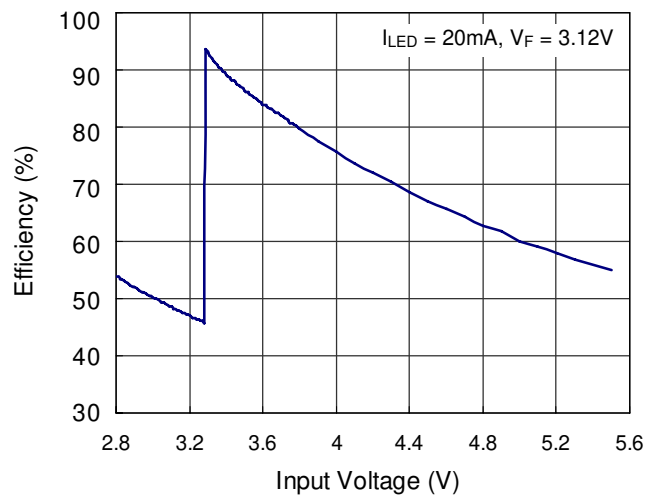

LED Current vs. Input Voltage

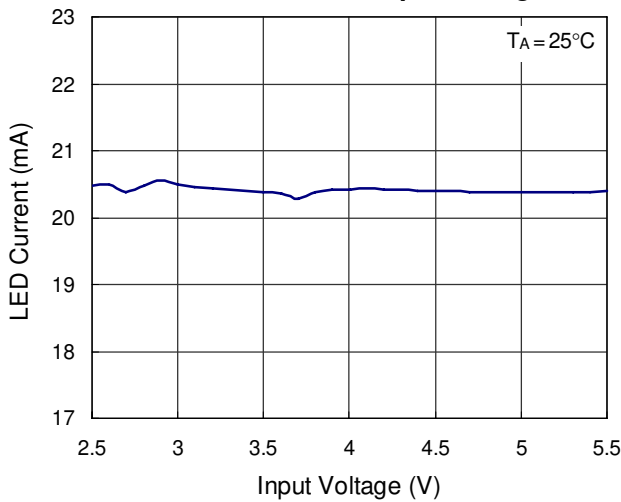

Input Current vs. Input Voltage

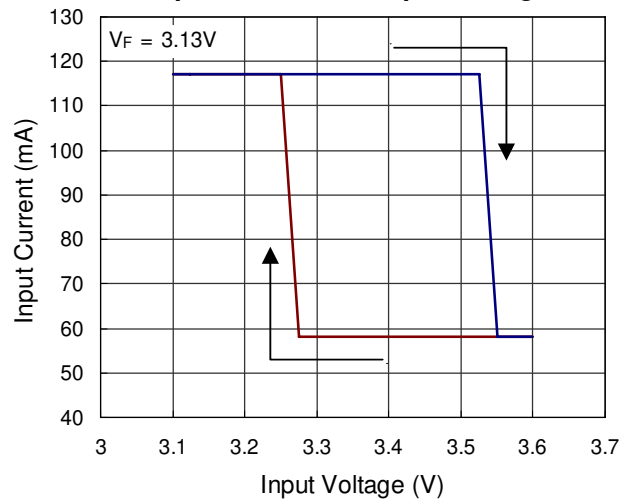

x1 Mode LED Current vs. Temperature

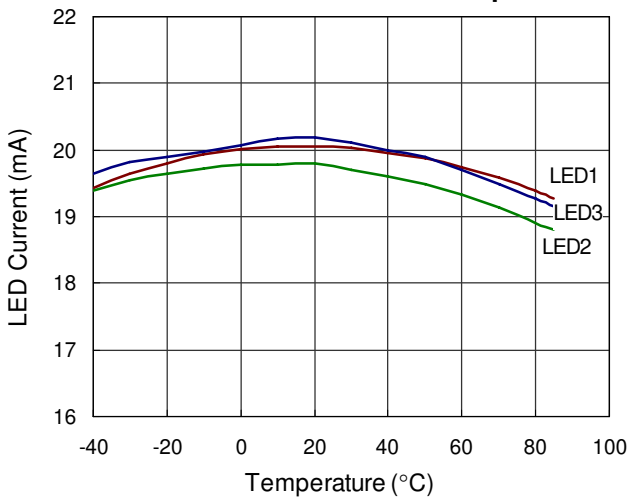

x2 Mode LED Current vs. Temperature

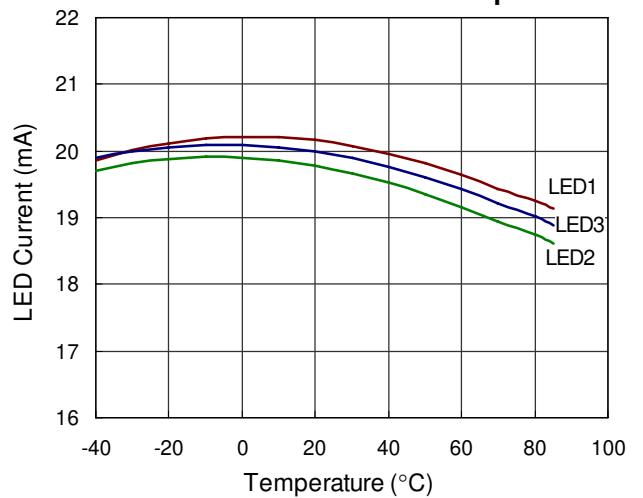

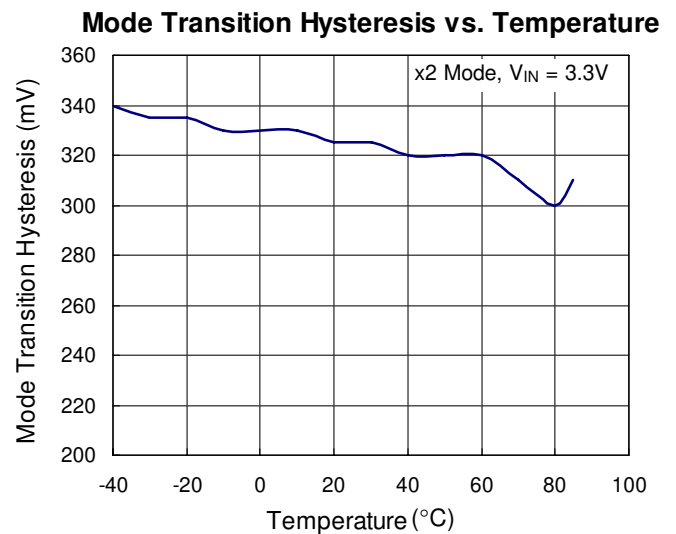
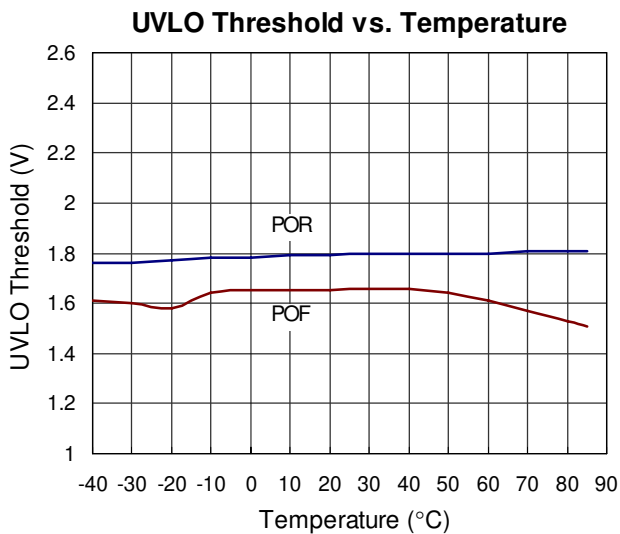
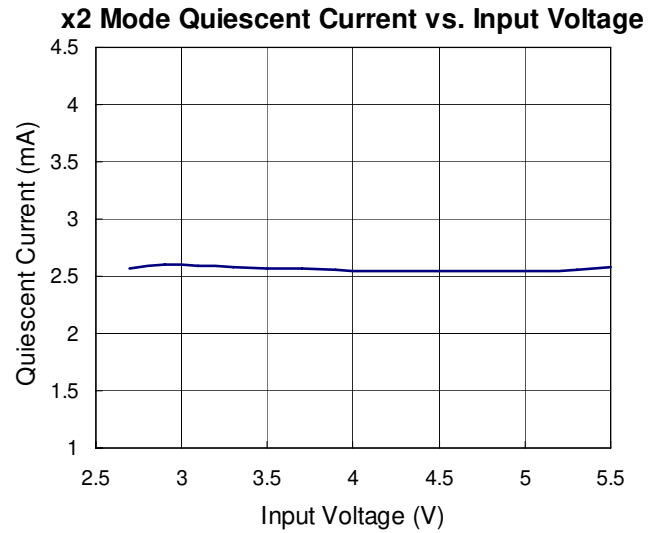
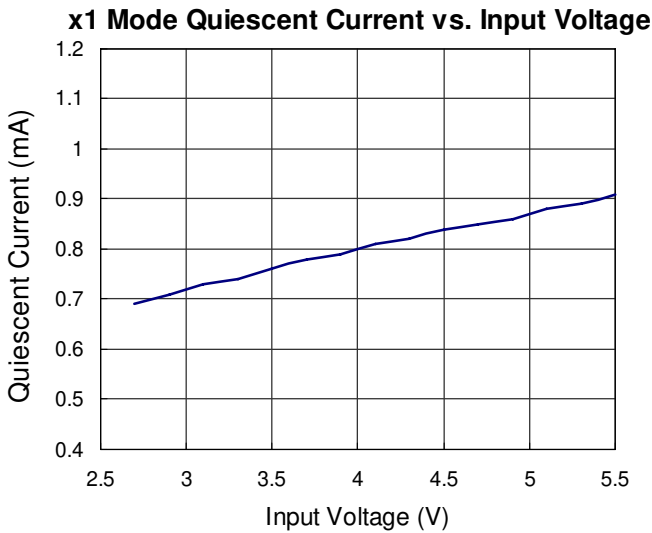
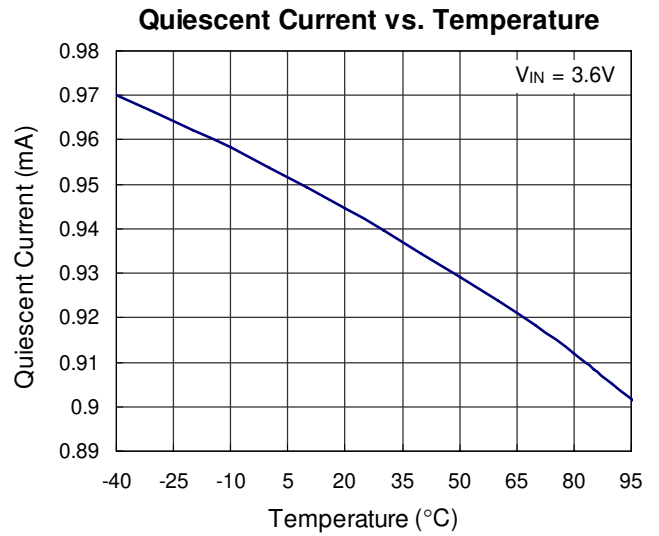
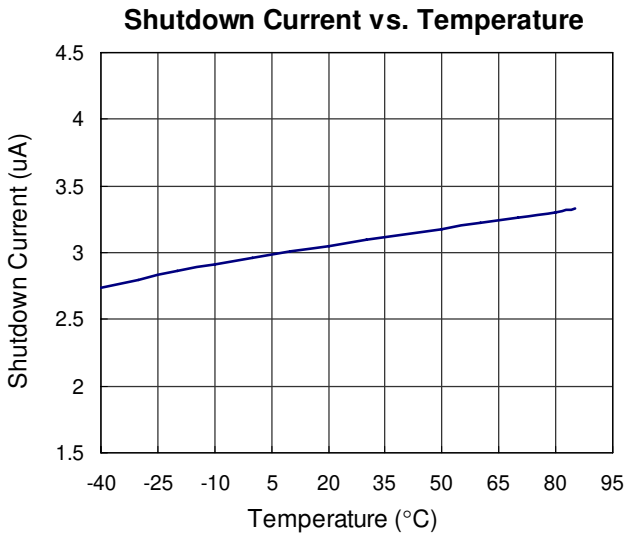

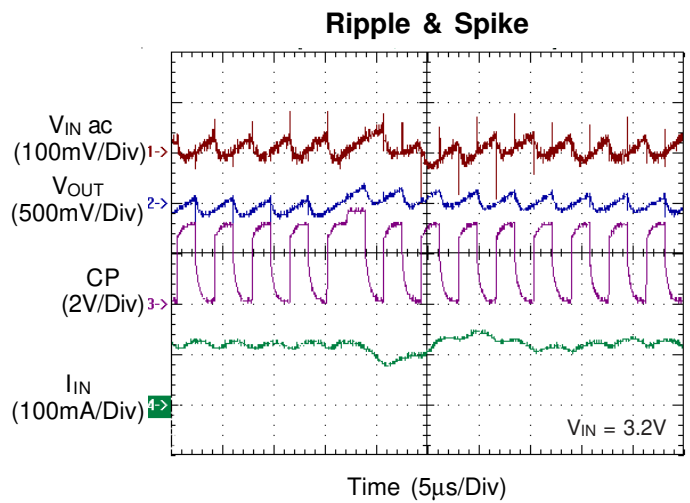
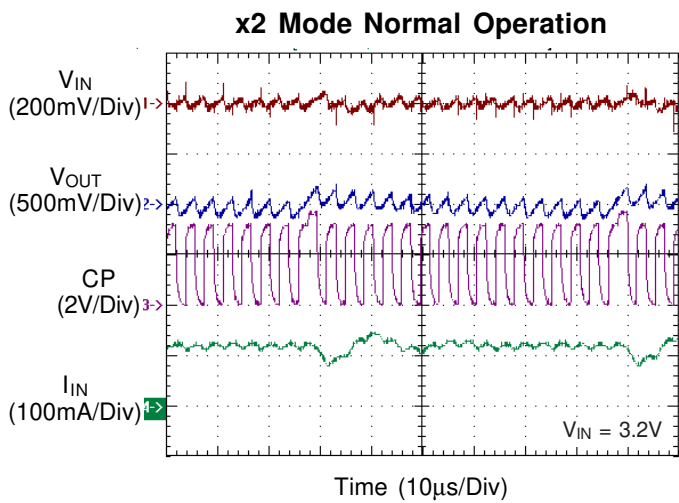
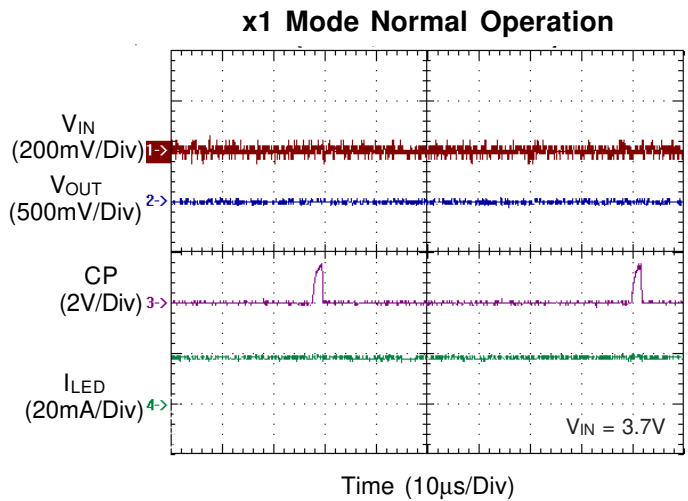
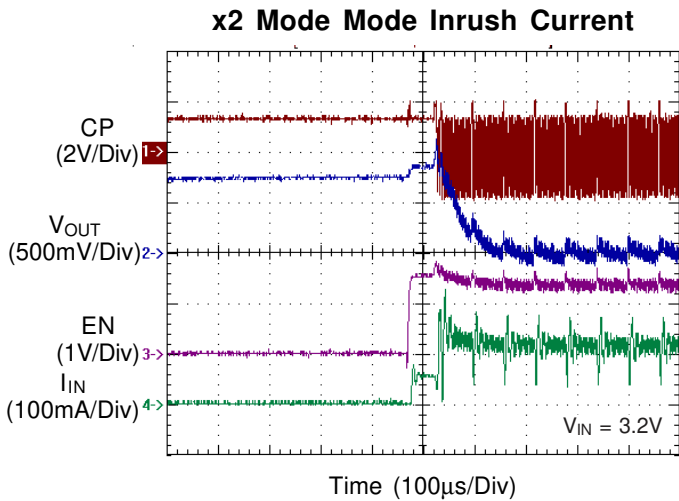
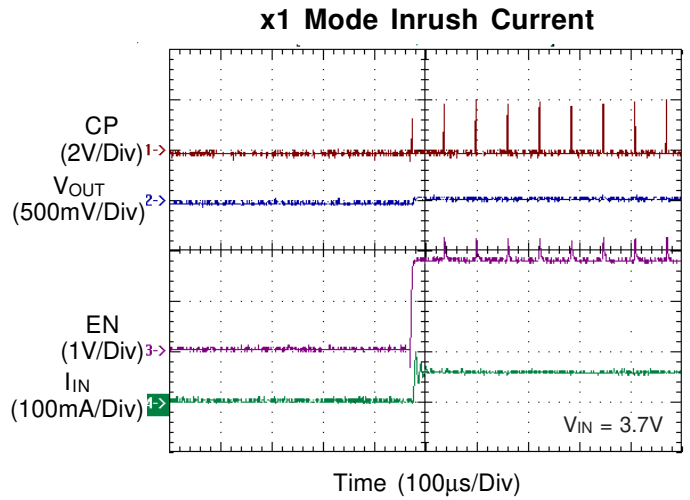
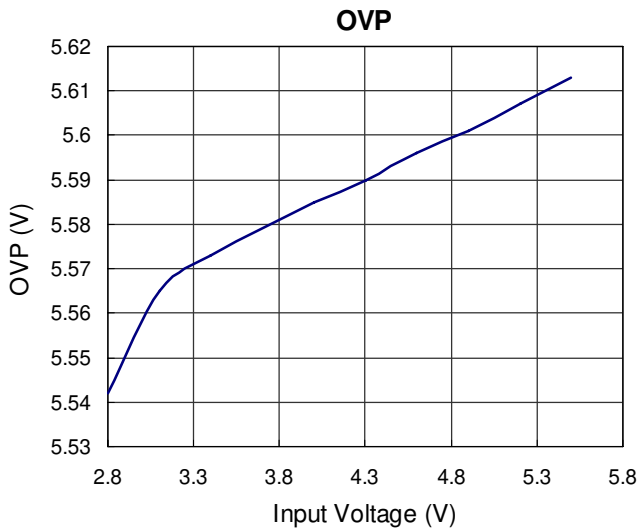

Application Information

The RT9363 is a high efficiency charge pump white LED driver. It provides low drop-out voltage current source to regulate 3 white LEDs current. For high efficiency, the RT9363 implements x1/x2 mode charge pump with auto mode selection. In the application with Li-ion battery, it provides a very cost-effective and high efficiency solution for driving white LEDs.

High Efficiency x1/x2 Charge Pump

Before the discussion of efficiency in RT9363, two things need to be illustrated. One is the Li-ion battery life time, the other is the forward voltage of white LED.

The Li-ion battery energy is not linearly proportion to battery voltage. In the Figure 2, It shows the 80% battery life of Li-ion is arranged in 3.65V to 4.0V. The other voltage range occupies less than 20% battery energy and is insignificant. In the backlight application, the forward voltage of white LEDs most likely falls in 3.2 to 3.5V @ $I_{LED} = 20mA$.

The development concept of RT9363 is based on the backlight application with Li-ion battery. RT9363 is very cost-effective product for driving white LEDs in backlight. It extends the 80% battery life by the reduction of open loop resistance at x1 mode and current source drop out voltage. Figure 3 is the efficiency diagram of RT9363, 80% battery life is marked by red rectangle. The RT9363 maximize the x1 mode operating range in the 80% battery life. Therefore, the efficiency is not significant different to that without x1.5 mode charge pump. The peak efficiency of RT9363 is 93% and average is 84%. Comparing to the LED drivers with x1.5 mode, only 1 to 2% efficiency loss by x2 mode. (Assume 5% battery life in charge pump mode and the efficiency difference of x1.5 and x2 modes is 25%, the efficiency loss thus is $5\% \times 25\% = 1.25\%$)

Soft Start

The RT9363 includes a soft start circuit to limit the inrush current at power on and mode switching. Soft start circuit holds the input current level long enough for output capacitor C_{OUT} reaching a desired voltage level. When the soft start is turning off, the RT9363 will not sink spike current from V_{IN} .

Mode Decision

The RT9363 uses a smart mode decision method to select the working mode for maximum efficiency. Mode decision circuit senses the output and LED voltage for up/down selection.

Dimming Control

RT9363 implements the pulse dimming method being used to control the brightness of white LEDs. There are 16 steps to set the current of white LEDs. The maximum LED current is up to 20mA that is sufficient for most application in backlight. The detail operation of brightness dimming is showed in the Figure 1.

Short Circuit Protection

A current limiting circuit is also included in the RT9363 for short circuit protection. Whenever output is shorted to GND and source a dangerously high current, the current limiting circuit takes over the output regulation circuit and reduces the output current at an acceptable level.

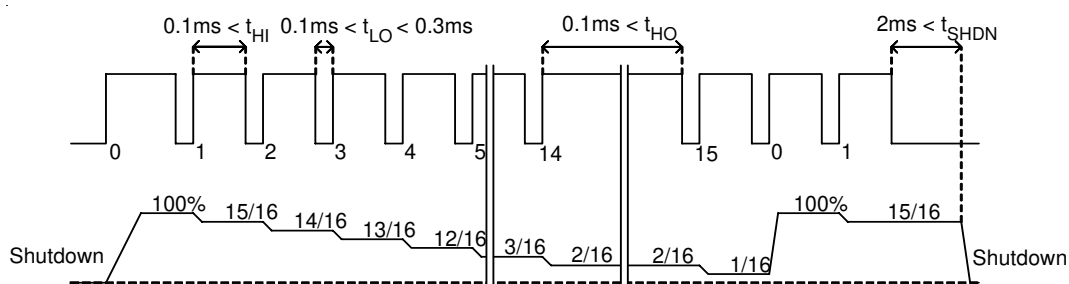

Figure 1. Brightness control by pulse dimming. RT9363 implements 16 steps brightness control

Selecting Capacitors

To get the better performance of RT9363, the selecting of peripherally appropriate capacitor and value is very important. These capacitors determine some parameters such as input and output ripple, power efficiency, maximum supply current by charge pump, and start-up time. To reduce the input and output ripple effectively, the low ESR ceramic capacitors are recommended. Generally, to reduce the output ripple, increasing the output capacitance C_{OUT} is necessary. However, this will increase the start-up time of output voltage. For LED driver applications, the input voltage ripple is more important than output ripple. Input ripple is controlled by input capacitor C_{IN} , increasing the value of input capacitance can further reduce the ripple. Practically, the input voltage ripple depends on the power supply impedance. Tantalum capacitors are not recommended for use with the RT9363. So tantalum capacitor values and ceramic capacitor values can use the same. But C_{OUT} can set tantalum capacitor; because during the charge pump is x2 mode the V_{OUT} is negative voltage.

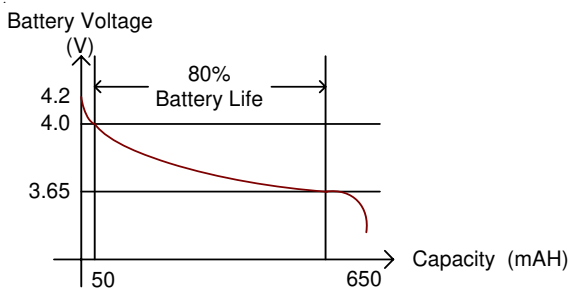

Figure 2. Li-ion Battery Energy Capacity Versus Battery Voltage.

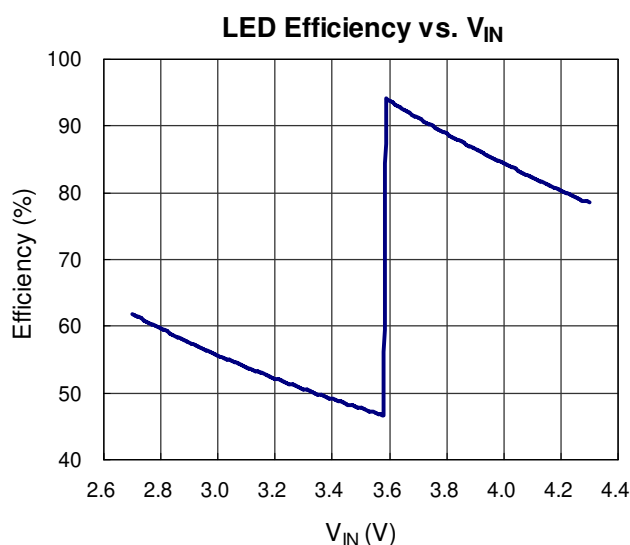

Figure 3. Efficiency of RT9363. ($I_{LED} = 60mA$, $V_F = 3.45V$)

PCB Board Layout

The RT9363 is a high-frequency switched-capacitor converter. Careful PCB layout is necessary. For best performance, place all peripheral components as close to the IC as possible. Place C_{IN} , C_{OUT} , and CP near to V_{IN} , V_{OUT} , CP, EN, and GND pin respectively. A short connection is highly recommended. The following guidelines should be strictly followed when designing a PCB layout for the RT9363.

- The GND must be soldered to a large ground plane for heat sinking and noise prevention. The through-hole vias located under IC is connected to ground plane of internal layer.
- V_{IN} traces should be wide to minimize inductance and handle the high currents. The trace running from battery to chip should be placed carefully and shielded strictly. The anodes of LEDs must connect to C_{IN} , not battery directly.
- Input and output capacitors must be placed close to the part. The connection between pins and capacitor pads should be copper traces without any through-hole via connection.
- The flying capacitors must be placed close to the part. The traces running from the pins to the capacitor pads should be as wide as possible. Long traces will also produce large noise radiation caused by the large dv/dt on these pins. Short trace is recommended.
- All the traces of LED and V_{IN} running from pins to LCM module should be shielded and isolated by ground plane. The shielding prevents the interference of high frequency noise coupled from the charge pump.

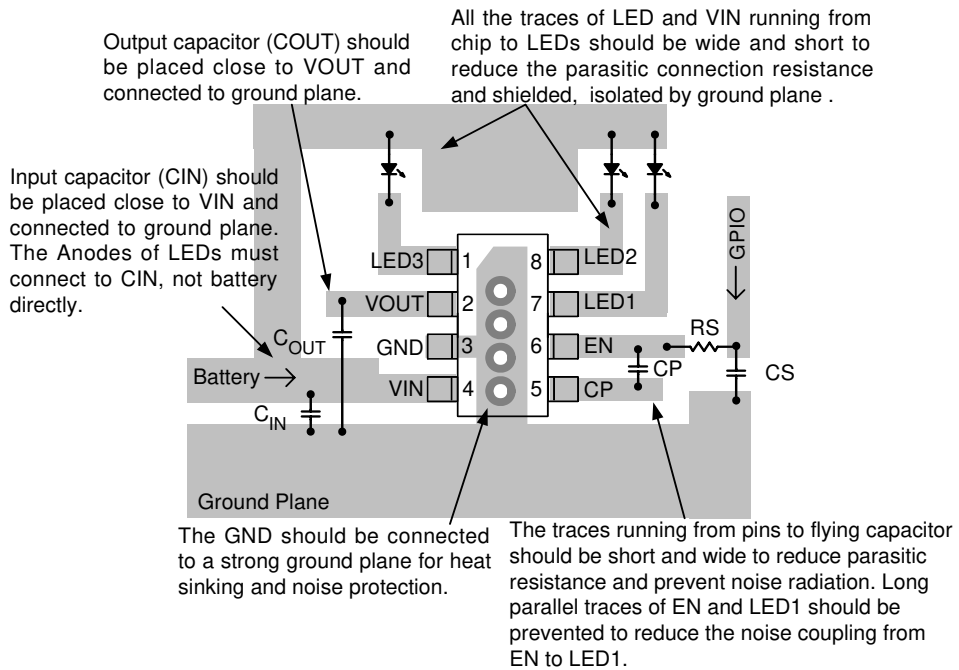

Figure 4. PCB Layout Guide.

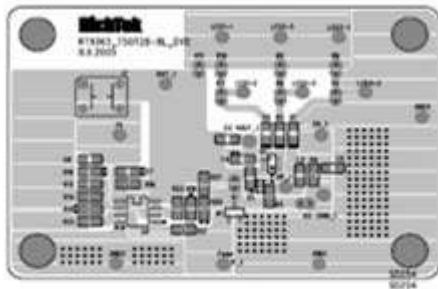

Figure 5. PCB Layout Top Layer.

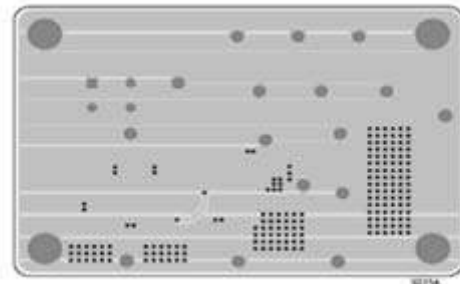
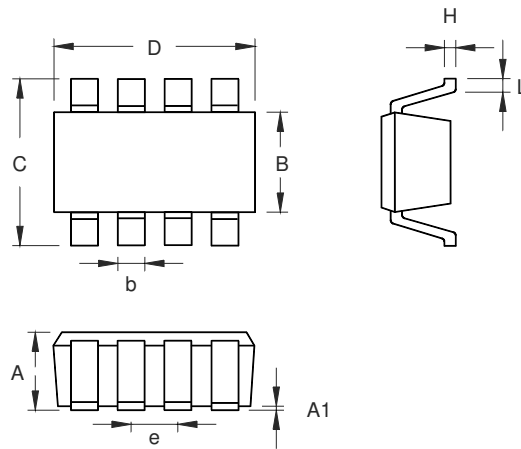

Figure 6. PCB Layout Bottom Layer.

Outline Dimension



Symbol	Dimensions In Millimeters		Dimensions In Inches	
	Min	Max	Min	Max
A	0.700	1.000	0.028	0.039
A1	0.000	0.100	0.000	0.004
B	1.397	1.803	0.055	0.071
b	0.220	0.380	0.009	0.015
C	2.591	3.000	0.102	0.118
D	2.692	3.099	0.106	0.122
e	0.585	0.715	0.023	0.028
H	0.080	0.254	0.003	0.010
L	0.300	0.610	0.012	0.024

TSOT-23-8 Surface Mount Package

RICHTEK TECHNOLOGY CORP.

Headquarter
 5F, No. 20, Taiyuen Street, Chupei City
 Hsinchu, Taiwan, R.O.C.
 Tel: (8863)5526789 Fax: (8863)5526611

RICHTEK TECHNOLOGY CORP.

Taipei Office (Marketing)
 8F-1, No. 137, Lane 235, Paochiao Road, Hsintien City
 Taipei County, Taiwan, R.O.C.
 Tel: (8862)89191466 Fax: (8862)89191465
 Email: marketing@richtek.com