



Datasheet 3/2019

High frequency differential choke with excellent attenuation to reduce dV/dt

APPROVALS:
SCCR by UL508A

FIN5955.(003 - 020).M
FEATURES

- Rated current from 3 to 20A
- Increases motor life
- Protects against voltage spikes on the motor
- Low power loss up to 250 Hz frequency output

BENEFITS

- 2 Year warranty
- Safety terminal block connectors
- Very compact design

MARKETS

- High speed motors up to 250 Hz
- AC motors controlled by VFDs
- Woodworking machinery
- Spindle motors closed loop

ORDERING CODE

FIN5955	.020	.M
Model	Current (A)	Connection
		M = Terminal block

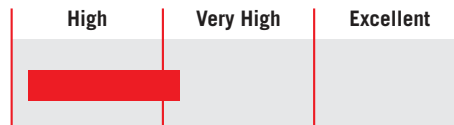
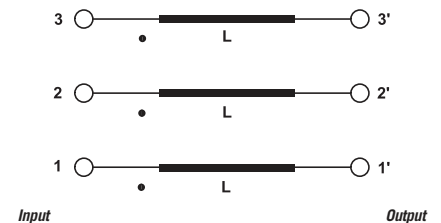
ATTENUATION INDICATOR

ELECTRIC DIAGRAM

TECHNICAL SPECIFICATIONS

Nominal voltage	0 / 600 Vac
Output frequency	0 - 250 Hz*
Rated current	3 to 20A
Carrier frequency (PWM)	0 - 16 kHz
Potential test voltage phase to phase	2400 Vdc (2 sec.)
Potential test voltage phase to ground	3200 Vdc (2 sec.)
IP Protection	IP20
Saturation current	4 x Rated current (Switch ON) 2 x In 10 seconds 1.5 In for 10 minutes 1.5 x Nominal current
Climatic class	-40 / +85° C
MTBF at 40°C	250.000 Hrs.

* Optional output frequency 850 Hz

ELECTRICAL CHARACTERISTICS

FIN5955	Rated Current 40°C	Rated Current 50°C	Power Loss (W)
.003.M	3	2	2.2
.006.M	6	5	2.4
.010.M	10	8	2.7
.020.M	20	17	3

CONNECTIONS

LINE			PE	
Solid Cable (mm ²)	Stranded Cable (mm ²)	Terminal Torque (Nm)	V (mm)	Torque (Nm)
0.2 - 10	0.2 - 6	1.2	M4	1.2
0.2 - 10	0.2 - 6	1.2	M4	1.2
0.2 - 10	0.2 - 6	1.2	M4	1.2
0.2 - 10	0.2 - 6	1.2	M4	1.2

TYPICAL MEASUREMENT

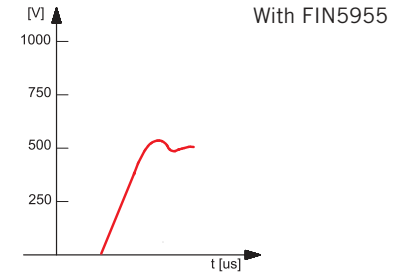
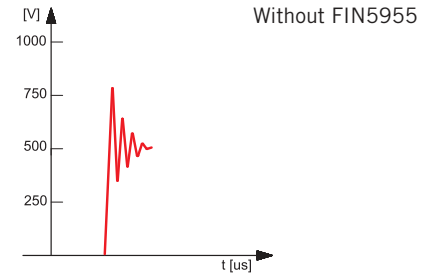

Example of measurement in a typical application using a servo drive

MECHANICAL DIMENSIONS mm

FIN5955	A	B	C	D	H	N	I	V	Weight kg.	Case
.003.M	60	101	125	113	51	11	4x17	M4	0.40	1
.006.M	60	101	125	113	51	11	4x17	M4	0.40	1
.010.M	60	101	125	113	51	11	4x17	M4	0.45	1
.020.M	60	101	125	113	51	11	4x17	M4	0.45	1

CASE 1

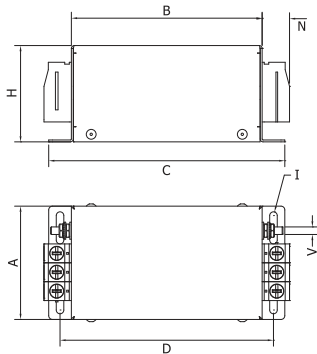

ASSEMBLY CONNECTION "M"

