

## AFBR-1715TZ

### DC to 50-Mbaud, 850-nm VCSEL Miniature Link Fiber-Optic Transmitter



#### Description

The Broadcom<sup>®</sup> AFBR-1715TZ is a high-performance optical transmitter designed for fiber-optic communication link with data rate from DC to 50Mbaud. The optical transmitter uses a 850-nm VCSEL source with integrated optics and driver IC to realize a low-powered device suitable for industrial applications with link distances up to several kilometers.

The AFBR-1715TZ is compliant with popular “industry-standard” ST<sup>1</sup> connectors, and it is designed for use with 62.5/125- $\mu\text{m}$  and 105- $\mu\text{m}$  multimode fiber (MMF).

#### Features

- RoHS compliant
- Data rate support from DC to 50 Mbaud
- Single 3.3V power supply
- Manufactured in an ISO 9001 certified facility
- 62.5/125- $\mu\text{m}$  or 105- $\mu\text{m}$  MMF
- Low current consumption and low power dissipation
- Class 1 FDA IEC 60825-1 laser safety compliant
- Operating temperature  $-40^{\circ}\text{C}$  to  $+85^{\circ}\text{C}$
- Excellent EMI and EMC behavior
- Incorporates 850-nm VCSEL and driver IC with LVTTTL input logic transmitter
- Hermetically sealed package

#### Applications

- Power substation automation
- HVDC
- Industrial networking over MMF

1. ST is a registered trademark of AT&T Lightguide Cable Connectors.

# Regulatory Compliance Table/Mechanical Dimensions and Module Drawing

Regulatory Compliance Feature	Test Method	Performance
Electrostatic Discharge (ESD) to the Electrical Pins	JEDEC JESD22-A114	HBM Class 2
Product Safety Laser Safety	EN62368-1 EN60825-1 EN60825-2 FDA/CDRH	Laser Class 1 Complies with 21 CFR 1040.10 and 1040.11 except for conformance with IEC 60825-1 Ed. 3., as described in Laser Notice No. 56, dated May 8, 2019
RoHS Compliance	—	Reference to RoHS Directive 2011/65EU Annex II and RoHS RL (EU) 2015-863
Moisture Sensitivity Level (MSL)	J-STD-020D	MSL 1 (Unlimited floor life time)

## Mechanical Dimensions

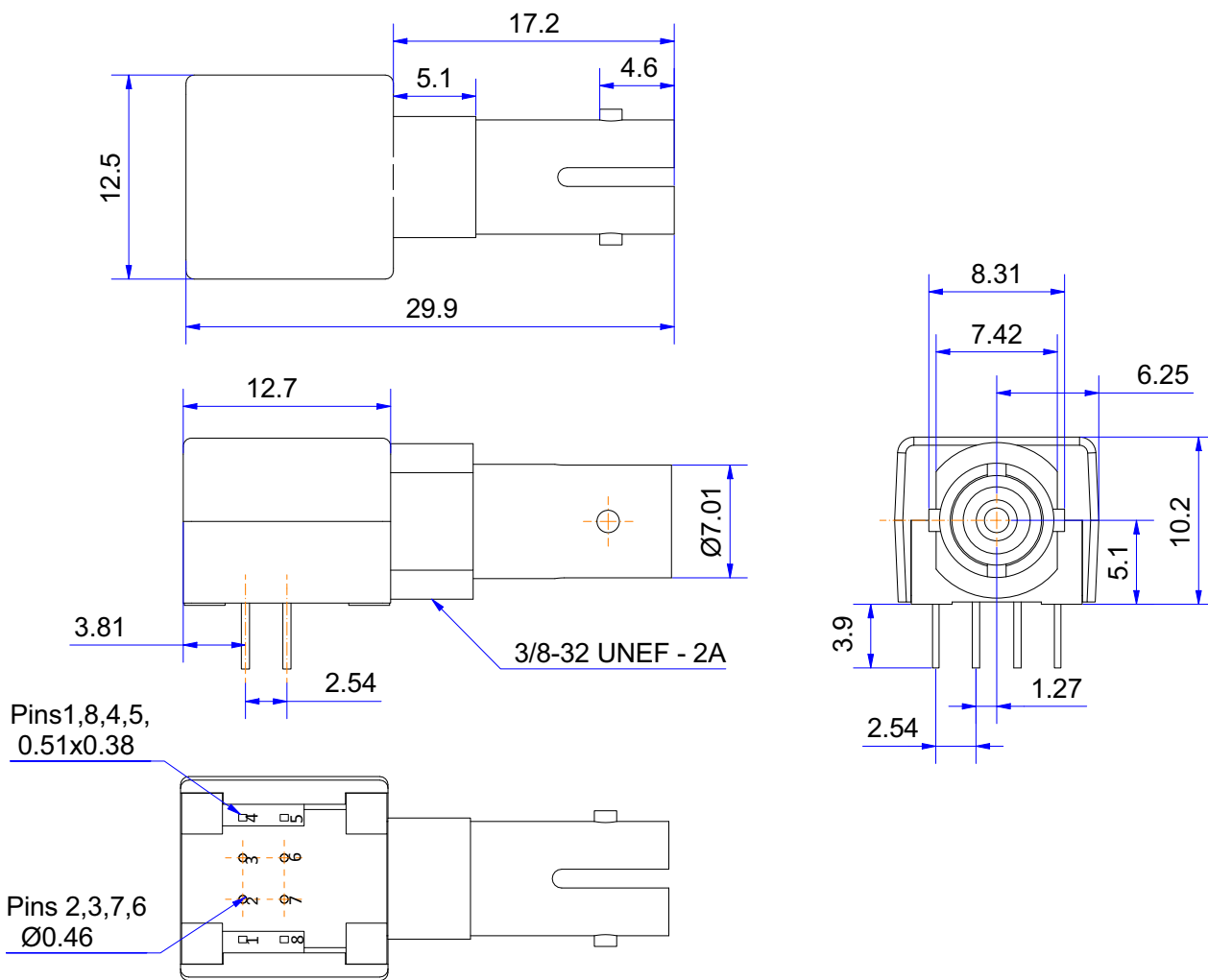

**NOTE:** Dimensions are in millimeters (mm).

# Pin Description

## Bottom View

Pins 1, 8, 4, 5,  
0.51x0.38

Pins 2, 3, 7, 6  
Ø0.46

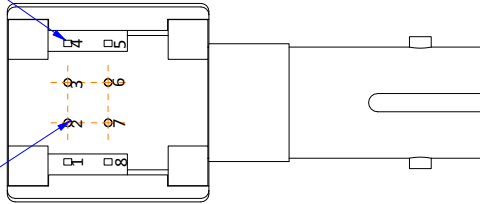

Pin	Name (Function)	Notes
1	N.C.	a
2	D <sub>IN</sub> (TX Data In [LVTTTL])	
3	V <sub>CC</sub> (3.3V Supply Voltage)	
4	N.C.	a
5	N.C.	a
6	V <sub>CC</sub> (3.3V Supply Voltage)	
7	GND (Ground)	
8	N.C.	a

a. Pins 1, 4, 5, and 8 are connected together internally.

# Recommended Application Circuit

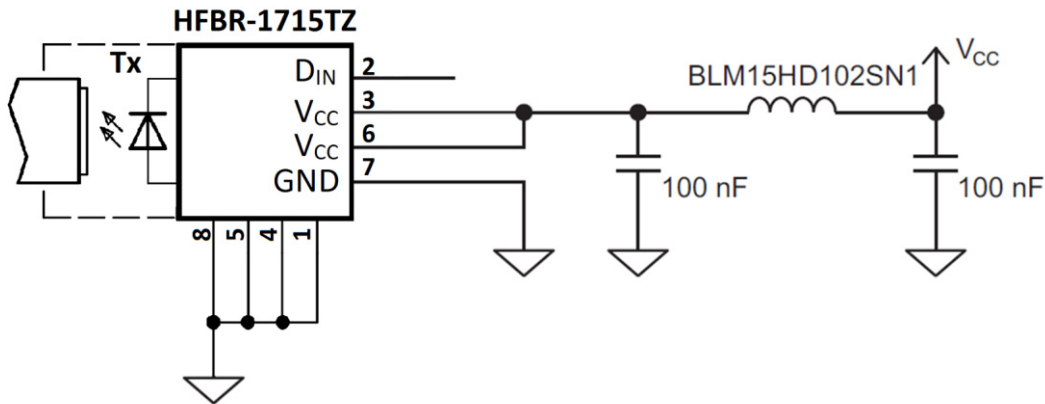

## Absolute Maximum Ratings

Stresses in excess of the absolute maximum ratings can cause catastrophic damage to the device. Limits apply to each parameter in isolation, all other parameters having values within the recommended operation conditions. It should not be assumed that limiting values of more than one parameter can be applied to the products at the same time. Exposure to the absolute maximum ratings for extended periods can adversely affect device reliability.

Parameter	Symbol	Min.	Max.	Units	Notes
Storage Temperature	$T_S$	-40	+85	°C	
Supply Voltage	$V_{CC}$	-0.3	3.6	V	
Data Input Voltage	$V_{IN}$	-0.5	$V_{CC}$	V	
Lead Soldering Temperature	$T_{sold}$	—	260	°C	MSL1
Lead Soldering Time	$t_{sold}$	—	10	s	

## Recommended Operating Conditions

Parameter	Symbol	Min.	Typ.	Max.	Units	Notes
Ambient Operating Temperature	$T_A$	-40	—	+85	°C	a
Supply Voltage	$V_{CC}$	3	3.3	3.6	V	
Signaling rate	B	DC	—	50	Mbaud	b

a. Electrical and optical specifications of the product are guaranteed across recommended ambient operating temperature range only.

b. Characterized with 50-Mbaud PRBS  $2^7-1$  pattern.

## Transmitter Electrical Characteristics

Parameter	Symbol	Min.	Typ.	Max.	Units	Notes
Supply Current	$I_{CC}$	—	6.5	10	mA	a
Power Dissipation	$P_{DISS}$	—	—	36	mW	
Data Input Voltage - Low	$V_{INL}$	0	—	0.8	V	
Data Input Voltage - High	$V_{INH}$	2	—	$V_{CC}$	V	
Data Input Capacitance	$C_{IN}$	—	5	—	pF	
Data Input Resistance	$R_{IN}$	—	80	—	kΩ	
Propagation Delay	$t_{TD}$	—	6	15	ns	

a. Typical value at 3.3V and 25°C.

## Transmitter Optical Characteristics

Parameter	Symbol	Min.	Typ.	Max.	Units	Notes
Optical Output Power Peak (62.5/125 $\mu\text{m}$ or 105 $\mu\text{m}$ )	$P_o$	-8.2	-3	+2	dBm	a
Extinction Ratio	EXT	10	—	—	dB	b
Logic-Low Optical Output Power Peak	$P_{o\_Logic\_Low}$	—	—	-37	dBm	c
Central Wavelength	$\lambda_C$	805	845	865	nm	a
Spectral Width – FWHM	$\Delta\lambda$	—	0.5	5	nm	a
Optical Rise Time (20% to 80%)	$t_r$	—	2	4	ns	a, d
Optical Fall Time (80% to 20%)	$t_f$	—	1.7	3	ns	a, d
Pulse Width Distortion	$t_{TPWD1}$	-7	—	+2	ns	d, e
Pulse Width Distortion	$t_{TPWD2}$	-5	—	+2	ns	d, f

- a. Typical values are for 3.3V and 25°C.
- b. Characterized with 01 pattern at 50Mbaud.
- c. DC to 2.5 MHz.
- d. Measured with a 200-MHz optical/electrical converter.
- e. Electrical input of 50 Mbaud, measured with a long input of low pulse followed by a high pulse.
- f. Electrical input of 50 Mbaud, 0101 pattern and 50% duty cycle. Pulse width is measured at 50% threshold.

Copyright © 2021 Broadcom. All Rights Reserved. The term “Broadcom” refers to Broadcom Inc. and/or its subsidiaries. For more information, go to [www.broadcom.com](http://www.broadcom.com). All trademarks, trade names, service marks, and logos referenced herein belong to their respective companies.

Broadcom reserves the right to make changes without further notice to any products or data herein to improve reliability, function, or design. Information furnished by Broadcom is believed to be accurate and reliable. However, Broadcom does not assume any liability arising out of the application or use of this information, nor the application or use of any product or circuit described herein, neither does it convey any license under its patent rights nor the rights of others.

