

1 2 3 4 5 6 7 8
 LEGEND = KEY PRODUCT CHARACTERISTICS

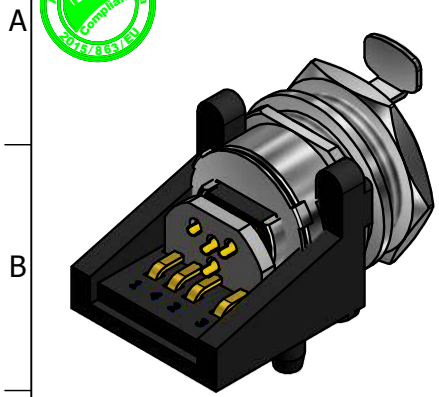

REVISION HISTORY				
REV	DESCRIPTION	DATE	BY	ECN
0	FIRST ISSUE	04/10/12	MH	---
1	CHANGE SUPPORT MATERIAL PA6 TO LCP-GREY	23/06/16	MH	9356
2	UPDATE DRAWING TO CURRENT PRODUCT	05/06/20	MH	9535



ISO VIEW

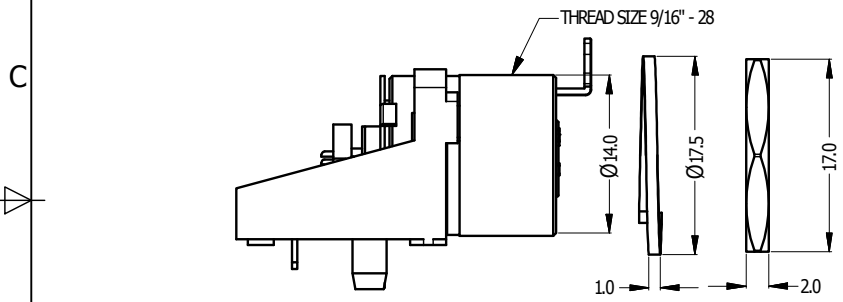
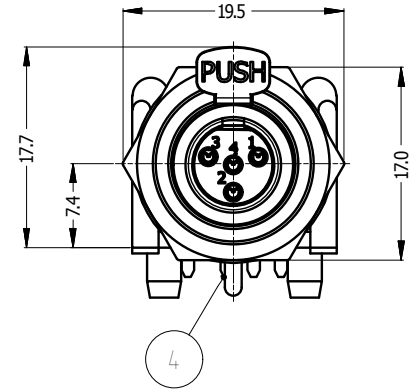
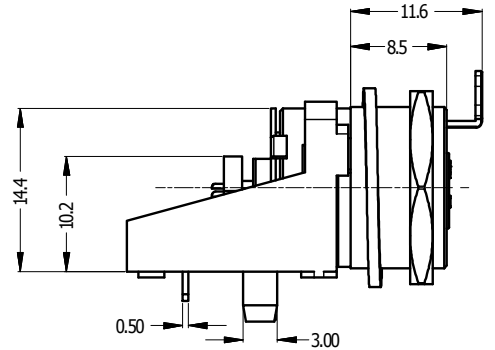
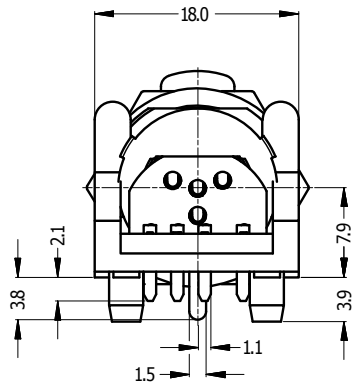

METAL WASHER

METAL NUT

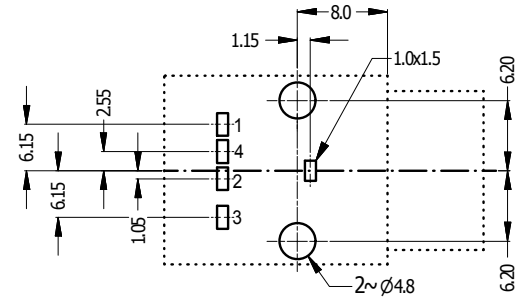
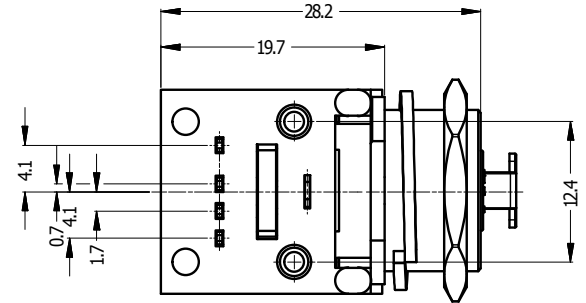

PCB LAYOUT (TOP VIEW)

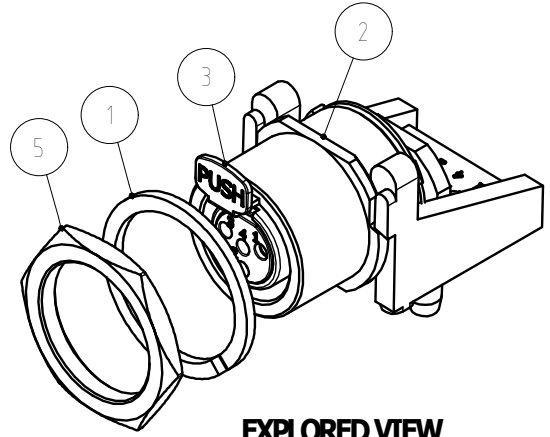

EXPLORED VIEW

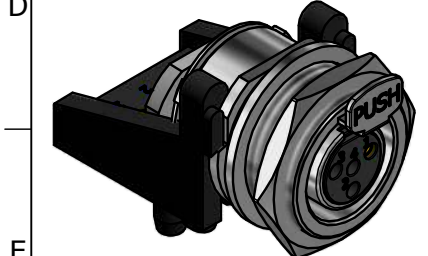

Specification:
 Mechanical
 Lifetime: Insert & withdraw >5000 cycle
 Insertion 6.1 lb/withdrawal 5.6 lb Max.

Electrical
 Contact resistance: <0.03 ohm
 Insulation resistance: >500Megohm
 Dielectric strength: 1000VDC
 Rated current: 5A

Notes:
 1. Connector is RoHS Compliant
 2. Materials are UL 94 V-0 Compliant.

ITEM	PART NUMBER	DESCRIPTION	QTY
5	50300395-321	METAL NUT - BRASS - NI PLATED	1
4	50300336-121	SOCKET CONTACTS - BRASS - Au PLATED	4
3	52080006-331	PUSH LEVEL - SUS 304- NI PLATED	1
2	55010859-100	AG4FCCH CONNECTOR WITHOUT HARDWARE	1
1	50300332-321	SPRING K5 METAL WASHER - NI PLATED	1

UNLESS OTHERWISE SPECIFIED TOLERANCE TO BE		THIS DOCUMENT IS THE PROPERTY OF AMPHENOL AUSTRALIA PTY. LTD. . NO PART THEREOF MAY BE REPRODUCED AND USED WITHOUT THE PRIOR WRITTEN CONSENT OF THE OWNER			
LINEAR	ANGULAR	MATERIAL:	DRN:	MH	DATE: 04/10/12
X ± 0.5	X' ± 1	SEE PART LIST	CKD:	MH	DATE: 05/06/20
XX ± 0.2	XX' ± 30'	BREAK ALL SHARP EDGES AND REMOVE ALL BURRS	APP'D:	PM	DATE: 05/06/20
XXX ± 0.1	XXX' ± 15'	DO NOT SCALE	FINISH:	SEE TABLE	
DIMENSIONS IN MILLIMETRES		SCALE:	3:2	SIZE:	A4

Amphenol		Amphenol Australia Pty.Ltd, 22 Industry Blvd, Carrum Downs, VIC 3201	
TITLE: MINI XLR 4 SKT FEMALE PANEL MOUNT RA PCB CUSTOMER DRAWING		PART No: AG4FCCH	
DRAWING NO. 55010859-100-1		SHEET 1/1	
CAD FILE 55010859100112			