

REV.	DESCRIPTION	DATE	APPROVED
A	Engineering Update w/o Changes	02/23/04	M. C.

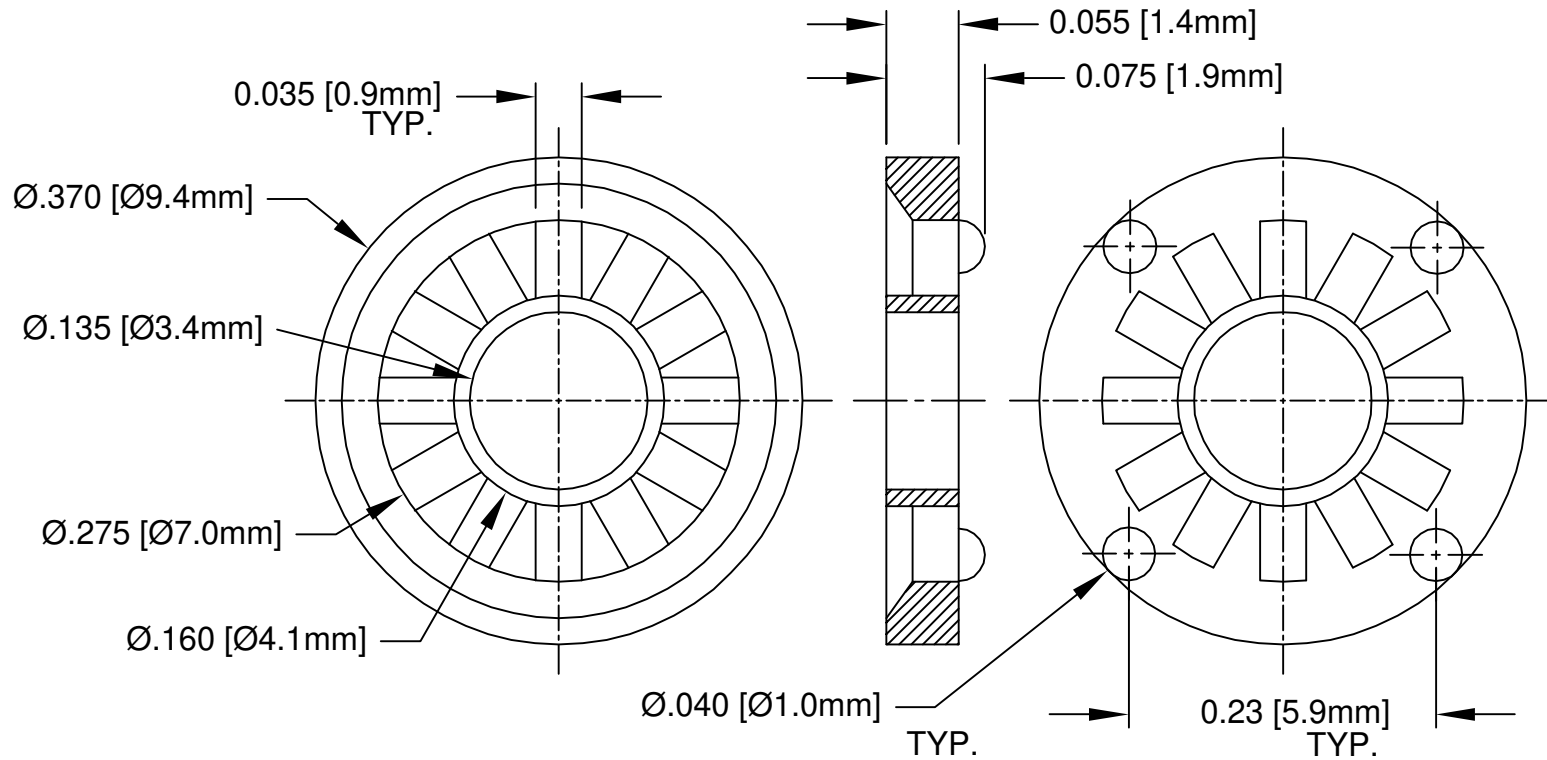

- MATERIAL: NYLON 6/6, 94V-2, NATURAL. BIVAR MATERIAL CODE 03-NL. BASF ULTRAMID NYLON 6/6 A3K NATURAL.
- GENERAL SPECIFICATIONS: BIVAR MOLDED COMPONENT SPECIFICATION BV00-E101.

STANDARD TOLERANCE (UNLESS OTHERWISE SPECIFIED)		<b>BIVAR</b> <sup>®</sup>	
DECIMALS	ANGULAR	4 THOMAS, IRVINE, CA. 92618	
.X ± .1	X° ± 1°	TEL: (949) 951-8808 FAX: (949) 951-3974	
.XX ± .01		<b>TITLE:</b> PERM-O-PAD IC MOUNT	
.XXX ± .005		<b>PART NO:</b> 607-075	
DESIGNED: <b>Sam Dagher</b>	DATE: <b>06/09/92</b>	REVISION: <b>A</b>	
CHECKED: <b>E. Muldoon</b>	DATE: <b>06/09/92</b>	<b>CAGE CODE :</b> 32559 <b>SHEET #</b> 1 <b>OF</b> 1	
CAD GENERATED DOCUMENT, DO NOT MEASURE DRAWING.			