

ITEM	Q'TY	PART NUMBER	PART DESCRIPTION
1	1	MPC3	Chrome Panel Mount Holder, 3mm
2	1	3XX-F	T-1 (3mm) Flanged LED
3	1	BWS24AWG-RD	24AWG Wire Lead, U.L. 1007, Red
4	1	BWS24AWG-BK	24AWG Wire Lead, U.L. 1007, Black
5	2	BST200-BK	Shrink Tubing, 0.500" Black

REV.	DESCRIPTION	DATE	APPROVED
A	Engineering Release.	07/27/07	M. C.
B	Updated 3UWC-0.6K-F with 3UWC1.035C-F	04/26/12	T. Y.
C	Updated LED offering	05/03/12	T. Y.
D	Updated Bi-Color Polarity Table	12/18/12	T. Y.
E	Edit Part Number on Page 2	11/11/13	G. W.
F	Updated LED Optical Characteristics	09/14/15	J. C.
G	Updated per EOL Notice	03/04/20	A. V.

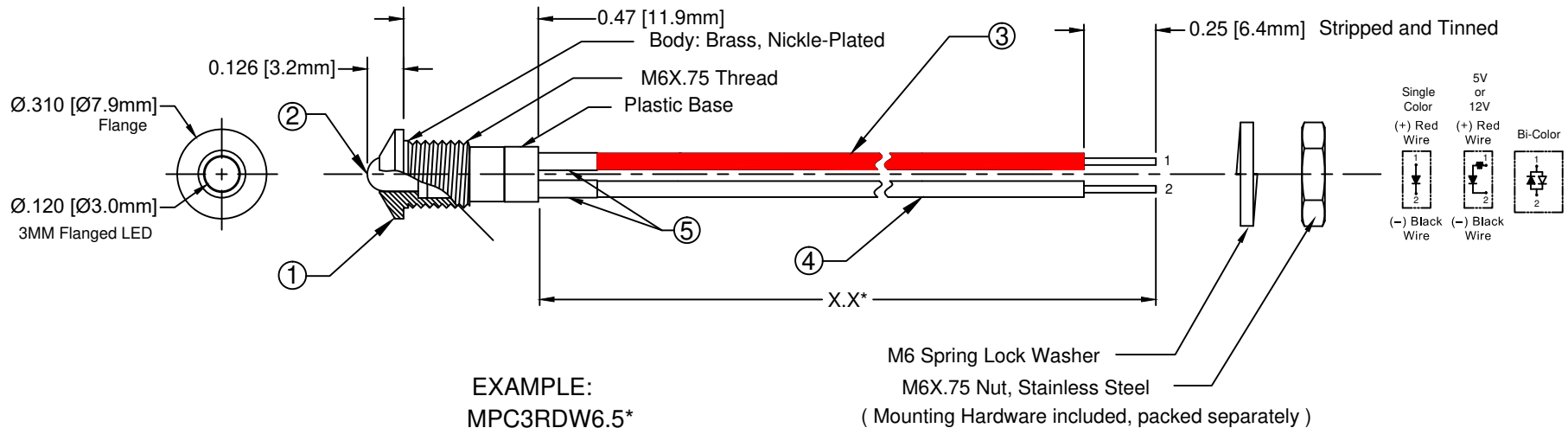

EXAMPLE:  
**MPC3RDW6.5\***

Series | LED Color, Lens Appearance | Wire Length in inches

BI-COLOR POLARITY		
LED P/N	(1) Cathode	(2) Cathode
3BC-F	Green	Red
3BC-Y/G-F	Green	Yellow

## ABSOLUTE MAXIMUM RATINGS (Ta = 25°C)

REVERSE VOLTAGE \_\_\_\_\_ 5V

REVERSE CURRENT ( VR=5V) \_\_\_\_\_ 100µA

OPERATING TEMPERATURE RANGE \_\_\_\_\_ -40°C ~ 85°C

STORAGE TEMPERATURE \_\_\_\_\_ -40°C ~ 100°C

LEAD SOLDERING TEMPERATURE (1/16" FROM BODY) \_\_\_\_\_ 260°C for 5 Seconds

STANDARD TOLERANCE (UNLESS OTHERWISE SPECIFIED)		ANGULAR		 <b>BIVAR</b> <sup>®</sup> 4 THOMAS, IRVINE, CA. 92618 TEL: (949) 951-8808 FAX: (949) 951-3974
DECIMALS				
.X	±.1	X°	± 1°	
.XX	±.02			
.XXX	±.010			
DESIGNED:	DATE:	TITLE: STD METAL PANEL MOUNT INDICATORS W/ WIRES		
<b>Dan Beckman</b>	<b>07/27/07</b>	DRAWING NO:	REVISION:	
		<b>MPC3XXWX.X</b>	<b>G</b>	
REVISED:	DATE:	SHEET SIZE:	CAGE CODE:	
<b>V. Chavez</b>	<b>03/04/20</b>	<b>A</b>	<b>32559</b>	
CHECKED:	DATE:	SCALE:	SHEET # 1 OF 3	
<b>A. Valdez</b>	<b>03/04/20</b>	<b>NONE</b>		
CAD GENERATED DOCUMENT, DO NOT MEASURE DRAWING				

REV.	DESCRIPTION	DATE	APPROVED
	SEE SHEET #1.		

LED Assy. No.	Chip			Lens Appearance	Electro-Optical Data @ 20mA				Viewing Angle 2 θ ½ (Deg)	LED P/N	
	Material	Peak Wave Length	Emitted Color		If (mA)	Vf (V)		Iv (mcd)			
						MAX	TYP	MAX			TYP
MPC3BWDWX.X	GaN/SiC	430	BLUE	DIFFUSED	25	4	4.5	10	35	3BWD-F	
MPC3GDWX.X	GaP/GaP	568	GREEN	DIFFUSED	30	2.1	2.8	25	35	3GD-F	
MPC3YDWX.X	GaAsP/GaP	590	YELLOW	DIFFUSED	30	2	2.8	20	35	3YD-F	
MPC3YTWX.X	GaAsP/GaP	590	YELLOW	TINTED	30	2	2.8	40	20	3YT-F	
MPC3ADWX.X	GaAsP/GaP	605	AMBER	DIFFUSED	30	2	2.8	25	35	3AD-F	
MPC3HDWX.X	GaAsP/GaP	625	HE RED	DIFFUSED	30	2	2.8	30	35	3HD-F	
MPC3RDWX.X	GaP/GaP	700	RED	DIFFUSED	20	2.1	2.8	2	20	3RD-F	
MPC3BCWX.X	GaAsP/GaP	625	RED	DIFFUSED	30	2.0	2.8	6	45	3BC-F	
	GaP/GaP	568	GREEN		30	2.1	2.8	6			
MPC3BCWX.X-Y/G	GaAsP/GaP	590	YELLOW	DIFFUSED	30	2.0	2.8	4	45	3BC-Y/G-F	
	GaP/GaP	568	GREEN		30	2.1	2.8	6			

		<b>BIVAR</b> <sup>®</sup>	
CAGE CODE	32559	DRAWING NO:	MPC3XXWX.X
SHEET SIZE	A	SCALE:	NONE
		REVISION:	G
		SHEET #	2 OF 3
<small>CAD GENERATED DOCUMENT, DO NOT MEASURE DRAWING</small>			

REV.	DESCRIPTION	DATE	APPROVED
	SEE SHEET #1.		

LED Assy. No.	Chip			Lens Appearance	Electro-Optical Data @ 20mA				Viewing Angle 2θ ½ (Deg)	LED P/N	
	Material	Peak Wave Length	Emitted Color		If (mA)	Vf (V)		Iv (mcd)			
						MAX	TYP	MAX			TYP
MPC3SGCW.X	GaP/GaP	568	GREEN	WATER CLEAR	30	2.1	2.8	50	20	3SGC-F	
MPC3SYCW.X	GaAsP/GaP	590	YELLOW	WATER CLEAR	30	2.0	2.8	50	20	3SYC-F	
MPC3SRCW.X	GaAlAs/GaAs	645	SUPER RED	WATER CLEAR	30	1.7	2.4	60	20	3SRC-F	
MPC3SRDW.X	GaAlAs/GaAs	645	SUPER RED	DIFFUSED	30	1.7	2.4	40	35	3SRD-F	
MPC3UGCW.X	AlGaInP	570	GREEN	WATER CLEAR	30	2.1	2.4	200	20	3UGC-F	
MPC3SUGCW.X	AlGaInP	570	GREEN	WATER CLEAR	30	2.1	2.4	300	35	3SUGC-F	
MPC3UYCW.X	AlGaInP	590	YELLOW	WATER CLEAR	30	2.0	2.4	300	20	3UYC-F	
MPC3URCW.X	GaAlAs/GaAs	645	RED	WATER CLEAR	30	1.7	2.4	200	35	3URC-F	
MPC3SURCW.X	AlGaInP	640	RED	WATER CLEAR	30	1.8	2.4	200	20	3SURC-F	
MPC3UWCW.X	InGaN/Sapphire	6500K	WHITE	WATER CLEAR	30	3.2	3.6	6000	35	3UWC1.035C-F	

LED Assy. No.	Chip			Lens Appearance	Absolute Max. Ratings			Electro-Optical Data @ 2mA			Viewing Angle 2 Y ½ (Deg)	LED P/N
	Material	Peak Wave Length λp(nm)	Emitted Color		Pd (mW)	If (mA)	Peak If(mA)	Vf (V)		Iv (mcd)		
								TYP	MAX	TYP		
MPC3GDLW.X	GaP/GaP	568	GREEN	DIFFUSED	10	7	-	2.1	2.6	4.0	35	3GDL-F
MPC3YDLW.X	GaAsP/GaP	590	YELLOW	DIFFUSED	10	7	-	2.0	2.6	2.0	35	3YDL-F
MPC3HDLW.X	GaAsP/GaP	625	RED	DIFFUSED	10	7	-	2.0	2.6	2.5	35	3HDL-F

**BIVAR**<sup>®</sup>

CAGE CODE	32559	DRAWING NO:	MPC3XXWX.X	REVISION:	G
SHEET SIZE	A	SCALE:	NONE	SHEET #	3 OF 3
CAD GENERATED DOCUMENT, DO NOT MEASURE DRAWING					