

THIS DRAWING IS UNPUBLISHED. RELEASED FOR PUBLICATION
 © COPYRIGHT BY TYCO ELECTRONICS CORPORATION. ALL RIGHTS RESERVED.

LOC		REV		REVISIONS			
AA	22	P	LN	DESCRIPTION	DATE	BY	APP'D
		E		ECO-11-014921	02DEC2011	JC	KZ

MECHANICAL:

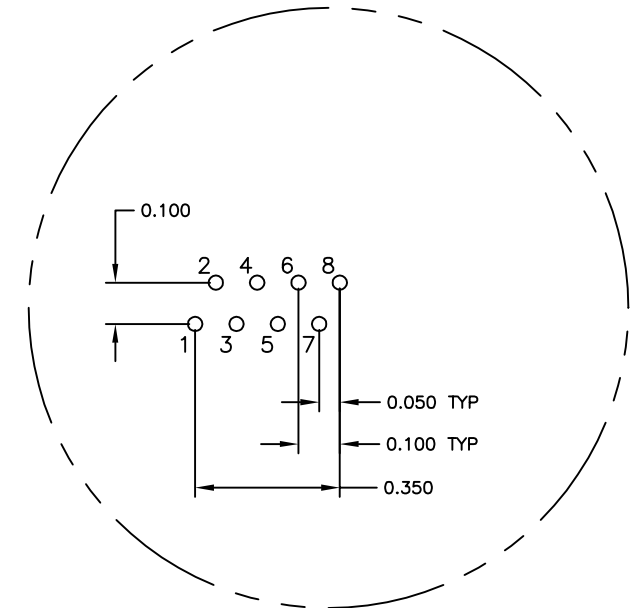
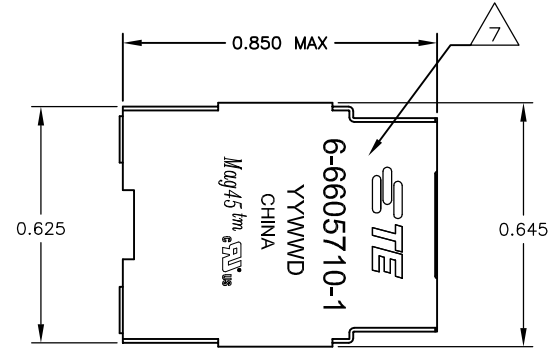

Pin Designations

- △ MATERIALS:
 HOUSING - THERMOPLASTIC PET POLYESTER FLAMMABILITY RATING UL 94V-0.
 SHIELD - .010" THICK, C26800 BRASS PREPLATED WITH 30μINCH MIN SEMI-BRIGHT NICKEL. SOLDER TABS POST DIPPED WITH 100μINCH MIN SAC SOLDER.
 MOD JACK CONTACTS - 0.0157 X 0.018" PHOSPHOR BRONZE, 50μINCH MIN OVERALL NICKEL UNDERPLATE WITH SELECT 50μINCH MIN HARD GOLD FINISH PLATE.
 SOLDERTAILS WITH 100μINCH MIN MATTE TIN AND/OR SAC SOLDER DIP.
 LIGHT EMITTING DIODE(LED) - DIFFUSED EPOXY LENS, .020" X .020" CARBON STEEL WIREFRAME LEADS PRE-PLATED WITH 80μINCH SILVER OVER 40μINCH NICKEL UNDERPLATE OVER 40μINCH COPPER UNDERPLATE. POST-PLATED WITH 100μINCH MIN MATTE TIN AND/OR SAC SOLDER DIP OR PURE TIN SOLDER DIP.
- △ RJ45 JACK CAVITY CONFORMS TO FCC RULES AND REGULATIONS PART 68, SUB PART F.
- △ MAGNETICS
 -IMPEDANCE: 100 OHMS
 -TURNS RATIO (CHIP,CABLE): TX = 1:1, RX = 1:1
 -OPEN CIRCUIT INDUCTANCE (OCL): 350μH MIN @100kHz, 0.1VRMS, 8mADC BIAS FROM 0°C TO 70°C, TX AND RX
 -PERFORMANCE @ 25°C:
 INSERTION LOSS (IL): 1.1dB MAX FROM 0.5MHz TO 100MHz
 RETURN LOSS (RL): 18dB MIN FROM 0.5MHz TO 30MHz
 18-20LOG(f/30)dB MIN FROM 30.1MHz TO 60MHz
 12dB MIN FROM 60.1MHz TO 80MHz
 CROSSTALK ATTENUATION: 35dB MIN FROM 0.5MHz TO 40MHz
 33-20*LOG(f/50)dB MIN FROM 40.1MHz TO 100MHz
 COMMON MODE REJECTION RATIO (CMRR): 30dB MIN FROM 0.5MHz TO 100MHz
 -ISOLATION VOLTAGE: 2250 VDC FOR 60 SECONDS DURATION.

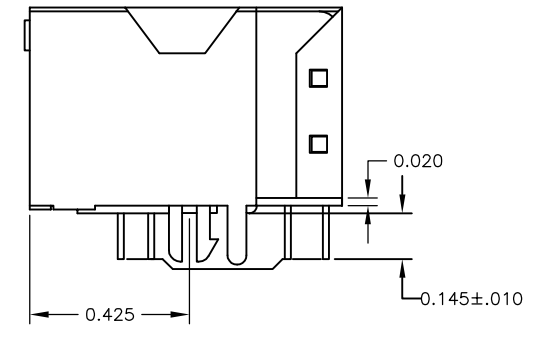
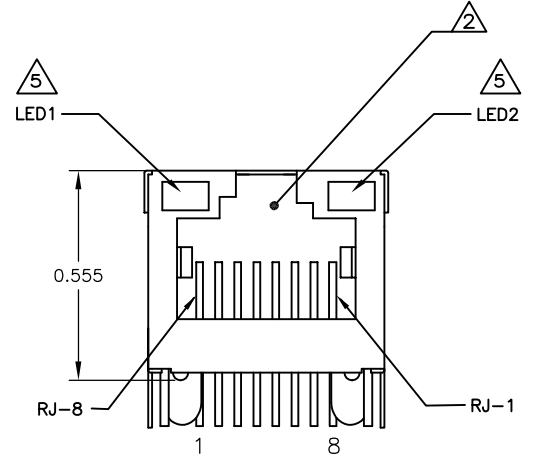

- 4. OPERATING TEMPERATURE: FROM 0°C - +70°C.
- △ THE 250 OHM LED RESISTORS ARE OPTIONAL, PLEASE SEE CHART FOR PRESENCE OR ABSENCE OF LED RESISTORS. IF THE LED WITHOUT 250 OHM RESISTORS, LED IS DRIVEN WITH CONSTANT CURRENT AT APPROX 20mA.
 LED COLOR: DOMINANT WAVELENGTH (λD): GREEN 568 nm TYP. @ IF=20mA
 FORWARD VOLTAGE (VF): GREEN 2.2V TYP. @ IF=20mA
 DOMINANT WAVELENGTH (λD): YELLOW 588 nm TYP. @ IF=20mA
 FORWARD VOLTAGE (VF): YELLOW 2.1V TYP. @ IF=20mA
 IF THE LED WITH 250 OHM RESISTORS,LED IS DRIVEN WITH 5V VOLTAGE AND THE MAX OPERATING CURRENT IS 20mA.
 LED COLOR : DOMINANT WAVELENGTH (λD): GREEN 568 nm TYP. @ VF=5V
 FORWARD CURRENT (IF): GREEN 12 mA TYP. @ VF=5V
- △ INDICATED CONNECTIONS ARE FOR NIC CONFIGURATION. THE MAGNETICS ARE ASYMMETRICAL, AND THEREFORE DO NOT SUPPORT AUTO-MDI/MDIX.
- △ TE CONNECTIVITY LOGO, PART NUMBER, DATE CODE, COUNTRY OF ORIGIN AND AGENCY APPROVAL MARKING IN APPROXIMATE LOCATION SHOWN.
- 8. THESE PARTS ARE RECOMMENDED FOR WAVE SOLDERING PROCESS, PREHEAT TEMPERATURE IS 120°C TO 160°C, 120 SECONDS TO 180 SECONDS, PEAK WAVE SOLDERING TEMPERATURE IS 260°C MAX, 10 SECONDS MAX.

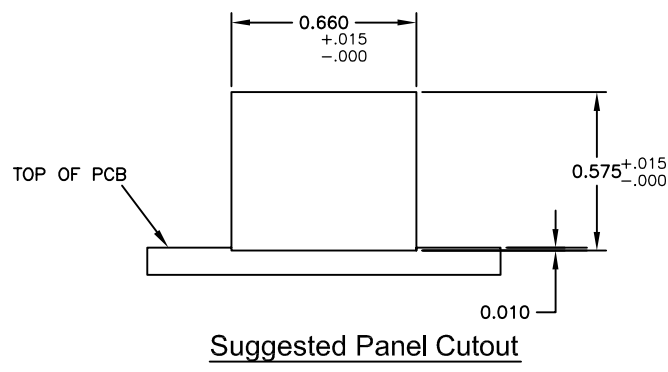

Suggested Panel Cutout

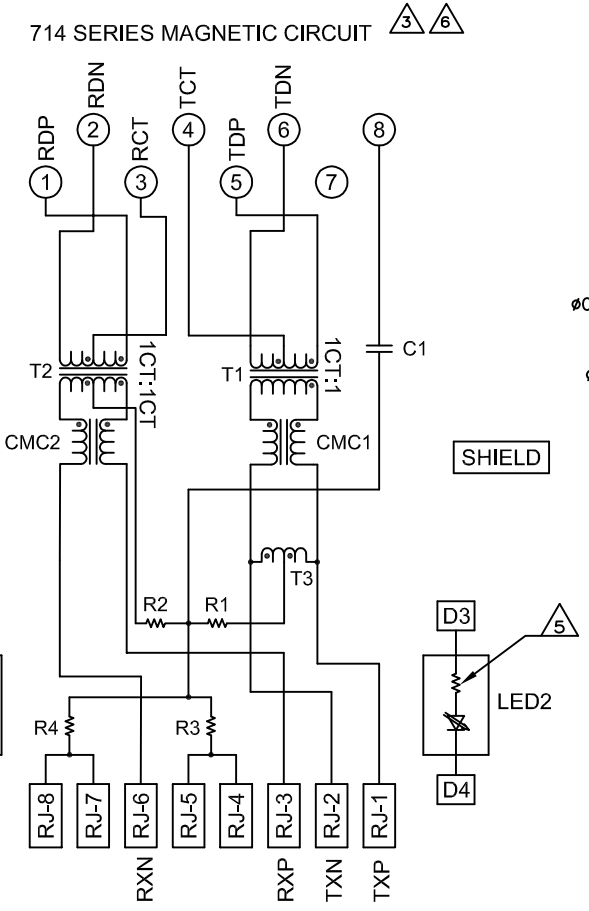

C1 = 1000 pF, 2kV CAPACITOR
 R1-R4 = 75 OHMS, 1/16 W RESISTORS

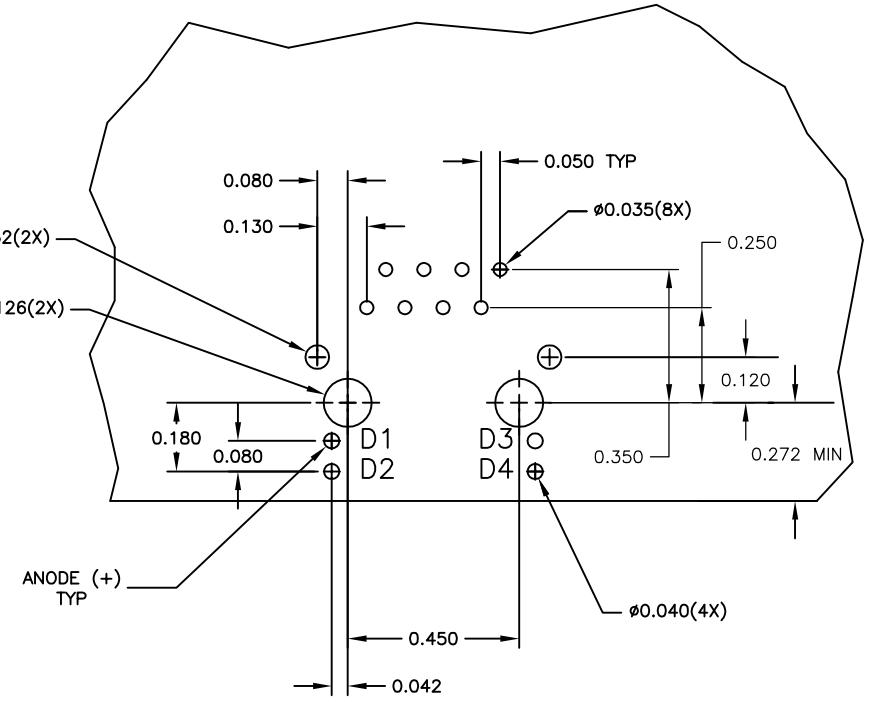

Suggested PCB Layout

OBSOLETE	YES	GREEN	YES	GREEN	YES	6-6605710-1
OBSOLETE	YES	GREEN	NO	YELLOW	NO	5-6605710-8
OBSOLETE	YES	GREEN	NO	GREEN	NO	5-6605710-7
OBSOLETE	NO	GREEN	YES	GREEN	YES	1-6605710-1
DECOUPLING CAPACITOR	LED1	250 OHMS RESISTOR	LED2	250 OHMS RESISTOR		PART NUMBER

THIS DRAWING IS A CONTROLLED DOCUMENT.		D. ATTADIA - TOMAROS		TE Connectivity	
D. FAROLE		D. FAROLE		NAME	
DIMENSIONS:		TOLERANCES UNLESS OTHERWISE SPECIFIED:		PRODUCT SPEC	
INCHES		APPROX		1X1	
0 PLC ± .010		1 PLC ± .010		108-2100	
2 PLC ± .005		2 PLC ± .005		APPLICATION SPEC	
3 PLC ± .005		3 PLC ± .005		SIZE	
4 PLC ± .005		4 PLC ± .005		A1	
MATERIAL		FINISH		WEIGHT	
CUSTOMER DRAWING		SCALE		SHEET 1 OF 1	