

Figure 1

1. INTRODUCTION

ROTA-CRIMP Crimping Tool 68321-1 (shown in Figure 1) is used to crimp Series 75 Power Lock Contact 53880-4 onto solid or stranded wire sizes 10, 8, or 6 AWG. Read these instructions thoroughly before using the tool.

NOTE

Dimensions in this instruction sheet are in millimeters [with inches in brackets]. Figures and illustrations are for reference only and are not drawn to scale.

Reasons for reissue of this instruction sheet are provided in Section 7, REVISION SUMMARY.

2. DESCRIPTION

The FRONT of the tool, into which the contact is inserted, can be identified by the tool part number on the link. The tool features a stationary die (6.35 mm [.250 in.] wide F crimp nest), rotatable anvil die with three settings, hold-down device, and contact locator. The anvil must be set to the wire size being used. The applicable wire size is stamped on the base of the anvil die. When closed, the dies form one crimping chamber.

The hold-down device and contact locator are mounted on a metal strip. The metal strip must be adjusted to accommodate the contact position during the crimping process.

3. CRIMPING PROCEDURE

Refer to Figure 2, and strip the wire to within the dimensions shown.



DO NOT use wires with missing or nicked conductor strands.

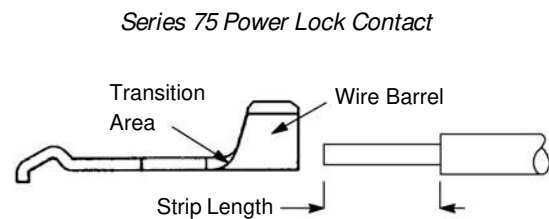

CONTACT	WIRE SIZE (AWG)	WIRE STRIP LENGTH
53880-4	10, 8, 6	7.95-9.53 [.313-.375]

Figure 2

Proceed as follows:

1. Open the tool head. Make sure that the anvil die is locked in position and that the locator pin is visible as shown in Figure 1. It is not necessary at this time to set the anvil die to a specific wire size.
2. Place a sample contact in the nest of the stationary die as shown in Figure 3. The open end of the wire barrel must be aligned in the nest.
3. Loosen the two screws securing the hold-down device and contact locator, and position the contact locator over the contact tongue as shown in Figure 3. Do not re-tighten the screws at this time.

NOTE

The hold-down device and contact locator must be properly adjusted so that the contact will remain aligned during the crimping process.

4. Slowly close the tool head, making sure the contact remains properly positioned in the nest. If the contact is cocked or otherwise out of line, realign it before proceeding. The contact should remain in the nest as shown in Figure 3. **DO NOT** deform the wire barrel.

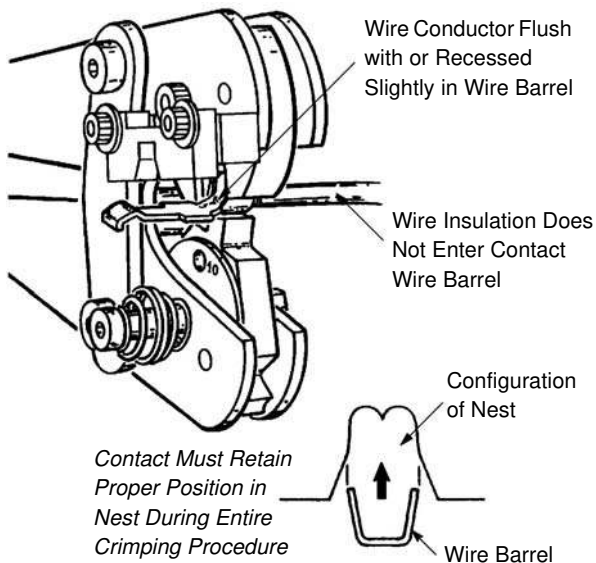

Figure 3

5. Crimp the contact by squeezing the tool handles. Then tighten screws of the hold-down device and contact locator. If the contact crimp is straight and the wire barrel has not been damaged, the tool is ready to use.

NOTE



If the tool has been preset for wire size 10 AWG - the smallest wire size-no further adjustment is necessary, even though wire size 8 or 6 AWG is to be terminated; the setting for wire size 10 will also accommodate wire size 8 or 6. However, if the anvil die is not set for wire size 10 and wire size 8 or 6 is desired, then the anvil die should be set to the appropriate wire size of either 8 or 6.

6. If the wire size marking is positioned for a wire size other than desired, depress the anvil die spring-loaded indexing pin and rotate the anvil die until the desired size appears. Then release the indexing pin and allow locator pin to snap into the hole which locks the anvil die in place for the desired size.

7. Open the tool head, and position the contact in the nest, locating the outer end of the wire barrel (wire-entry end) so that it extends from the nest area between 0.76 to 1.02 mm [.030 to .040 in.] as shown in Figure 4.

Hold-Down Device and Contact Locator Screws

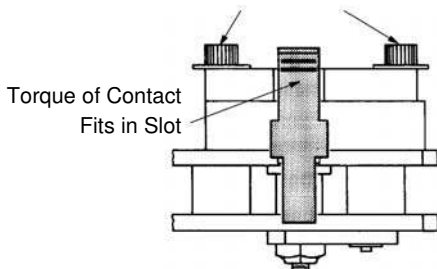

Figure 4

8. Close tool head just enough to retain the contact; then insert the wire into the wire barrel, making sure the wire does not extend beyond the wire barrel. See Figure 5.

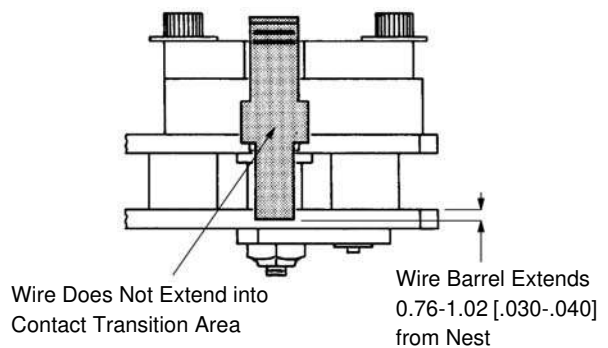

Figure 5

9. Slowly squeeze the handles, making sure contact remains aligned properly in the nest. It may be necessary to open the handles slightly, allowing the contact to be re-adjusted in the nest. Continue to squeeze the handles to complete the crimp.

4. CRIMP INSPECTION

Inspected the crimped contact according to Figure 6. Poorly crimped contacts can be avoided through careful use of these instructions.

NOTE



For a detailed inspection requirements, refer to Application Specification 114-6032.

Crimp Inspection

Wire Strands Visible Here - Insulation Must Not Enter Wire Barrel

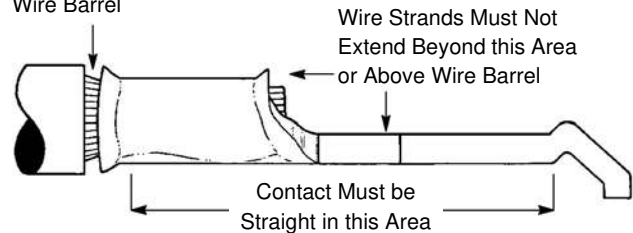

Figure 6

5. MAINTENANCE AND INSPECTION

5.1. Daily Maintenance

It is recommended that each operator of the tool be made aware of-and responsible for-the following steps of daily maintenance:

1. Remove dust, moisture, and other contaminants with a clean brush, or a soft, lint-free cloth. DO NOT use objects that could damage the tool.

2. Make sure the proper retaining pins are in place and secured with the proper retaining rings.
3. Make certain all pins, pivot points, and bearing surfaces are protected with a THIN coat of any good SAE 20 motor oil. DO NOT oil excessively.
4. When the tool is not in use, keep the handles closed to prevent objects from becoming lodged in the crimping dies and store the tool in a clean, dry area.

5.2. Periodic Inspection

Regular inspections should be performed by quality control personnel. A record of scheduled inspections should remain with the tool or be supplied to personnel responsible for the tool. Though recommendations call for at least one inspection a month, the inspection frequency should be based on the amount of use, ambient working conditions, operator training and skill, and established company standards. These inspections should be performed in the following sequence:

A. Visual

1. Remove all lubrication and accumulated film by immersing the tool (handles partially closed) in a suitable commercial degreaser that will not affect paint or plastic material.
2. Make certain all retaining pins are in place and secured with retaining rings. If replacements are necessary, refer to Section 6.
3. Inspect the head assembly, with special emphasis on checking for worn, cracked, or broken dies. If damage to any part of the head assembly is evident, refer to Section 6, for information on obtaining further evaluation and repair. Examples of possible damaged die closure surfaces are shown in Figure 7.

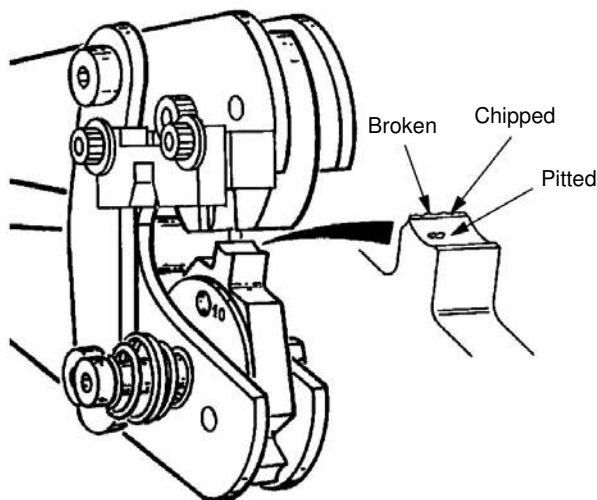

Figure 7

B. Handle Adjustment

The handle adjustment should be checked to ensure that the dies are bottoming properly. The handle adjustment feature is provided to compensate for normal tool wear. To check handle adjustment, first close handles until dies are bottomed, but not under pressure. Then measure the distance between handles as shown in Figure 8.

Adjustment is too tight if measurement exceeds 35.05 mm [1.38 in.] Proceed as follows:

1. Turn both adjustment (ADJ) screws counterclockwise approximately one-half to three-quarter turn.
2. Turn, but do not remove, both lock (LOCK) screws counterclockwise.
3. Flex tool by opening and closing the handles.
4. Tighten both lock screws.
5. Close the handles until the dies are bottomed but not under pressure. Check the measurement between the handles and, if necessary, repeat the adjustment procedure.

Adjustment is too loose if measurement is less than 28.7 mm [1.13 in.]. Proceed as follows:

1. Turn both lock (LOCK) screws counterclockwise approximately one-half to three-quarter turn.
2. Turn both adjustment (ADJ) screws clockwise approximately one-half to three-quarter turn.

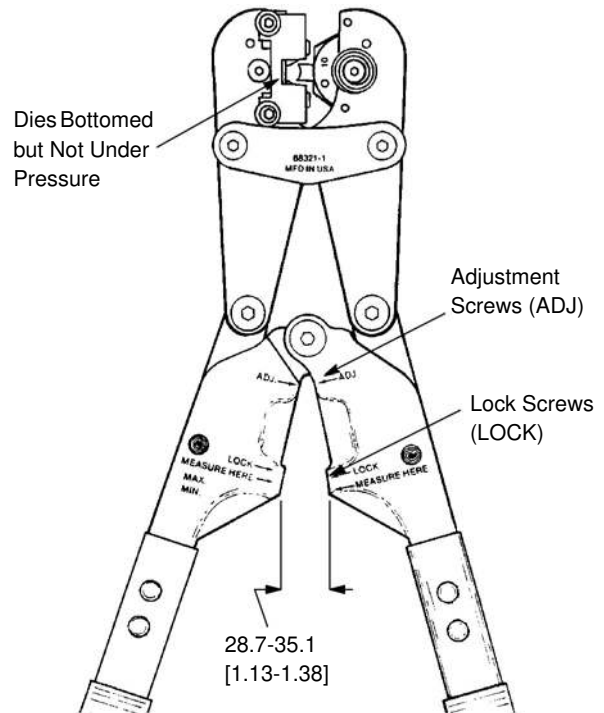
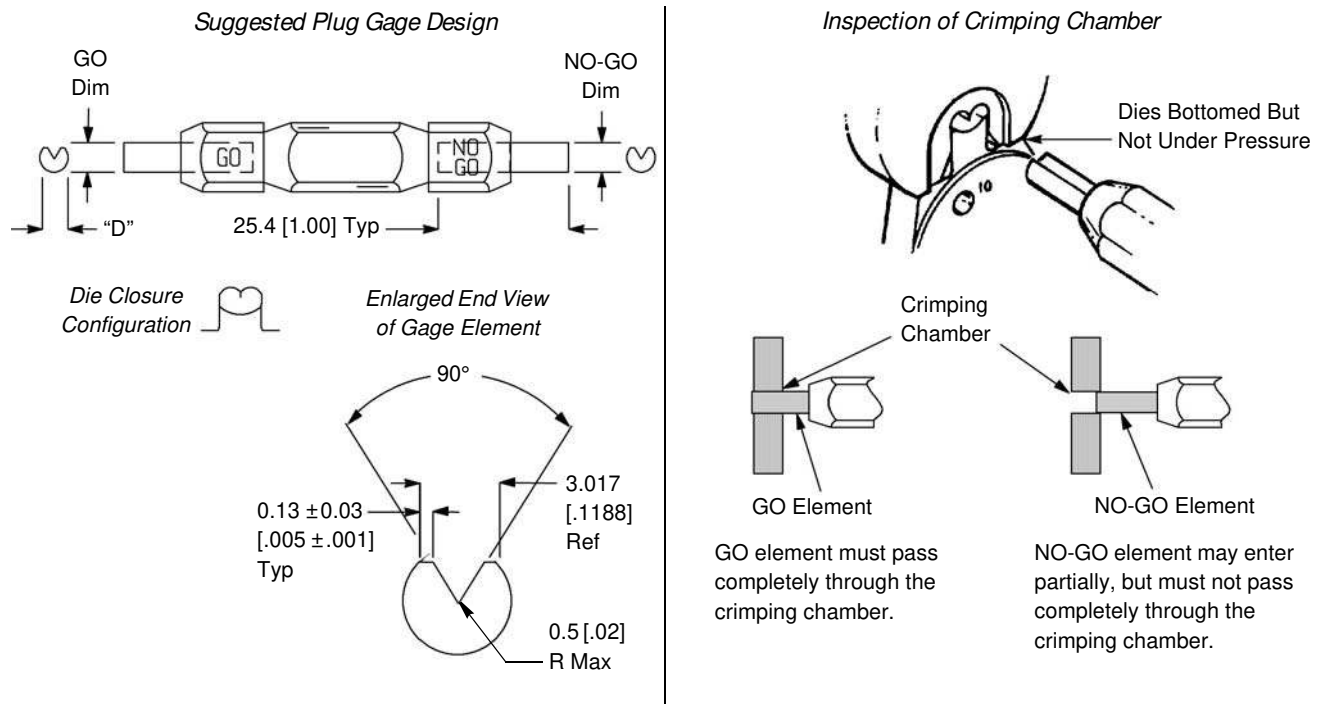

Figure 8



68321-1 F-CRIMP GAGE

WIRE SIZE(AWG)	GAGE ELEMENT DIMENSION		D (Diameter)	
	GO	NO-GO	GO	NO-GO
10	2.588-2.596 [.1019-.1022]	2.789-2.791 [.1098-.1099]	3.467-3.475 [.1365-.1368]	3.604-3.607 [.1419-.1420]
8	2.969-2.977 [.1169-.1172]	3.170-3.172 [.1248-.1249]	3.736-3.744 [.1471-.1474]	3.886-3.889 [.1530-.1531]
6	3.604-3.612 [.1419-.1422]	3.805-3.807 [.1498-.1499]	4.234-4.242 [.1667-.1670]	4.402-4.404 [.1733-.1734]

Figure 9

3. Flex tool by opening and closing handles.
4. Tighten both lock screws.
5. Close the handles until the dies are bottomed but not under pressure. Check the measurement between the handles and, if necessary, repeat the adjustment procedure.

C. Gaging the Crimping Chamber

This inspection requires the use of plug gages conforming to the dimensions provided in Figure 9.

To gage the crimping chamber, proceed as follows:

1. Remove traces of oil or dirt from the crimping chamber and plug gage.
2. Perform handle adjustment procedure according to Paragraph 5.2,B.
3. Close handles until dies are bottomed but not under pressure.
4. Insert GO element into the crimping chamber; but do not force it. The GO element must pass through the length of the crimping chamber. See Figure 9.

5. In the same manner, try to insert the NO-GO element into the crimping chamber. The NO-GO element may enter partially, but must not pass completely through the length of the crimping chamber. See Figure 9.

If the crimping chamber conforms to the gage inspection, the dies are considered dimensionally correct and should be lubricated with a THIN coat of any good SAE 20 motor oil. If the crimping chamber does NOT conform to the gage inspection, the dies must be returned for further evaluation and repair.

For additional information regarding the use of a plug gage, refer to Instruction Sheet 408-7424.

6. REPLACEMENT AND REPAIR

Customer-replaceable parts are listed in Figure 10.

A complete inventory should be stocked and controlled to prevent lost time when replacement of parts is necessary. Parts other than those listed should be replaced by TE Connectivity to ensure quality and reliability. Order replacement parts through your representative, or call 1-800-526-5142, or send a facsimile of your purchase order to 717-986-7605, or write to:

CUSTOMER SERVICE (038-035)
 TYCO ELECTRONICS CORPORATION
 PO BOX 3608
 HARRISBURG PA 17105-3608

For repair service, contact a TE Representative at
 1-800-526-5136.

7. REVISION SUMMARY

- Updated document to corporate requirements
- Changed dimension information in Figure 9
- Changed table in Figure 9

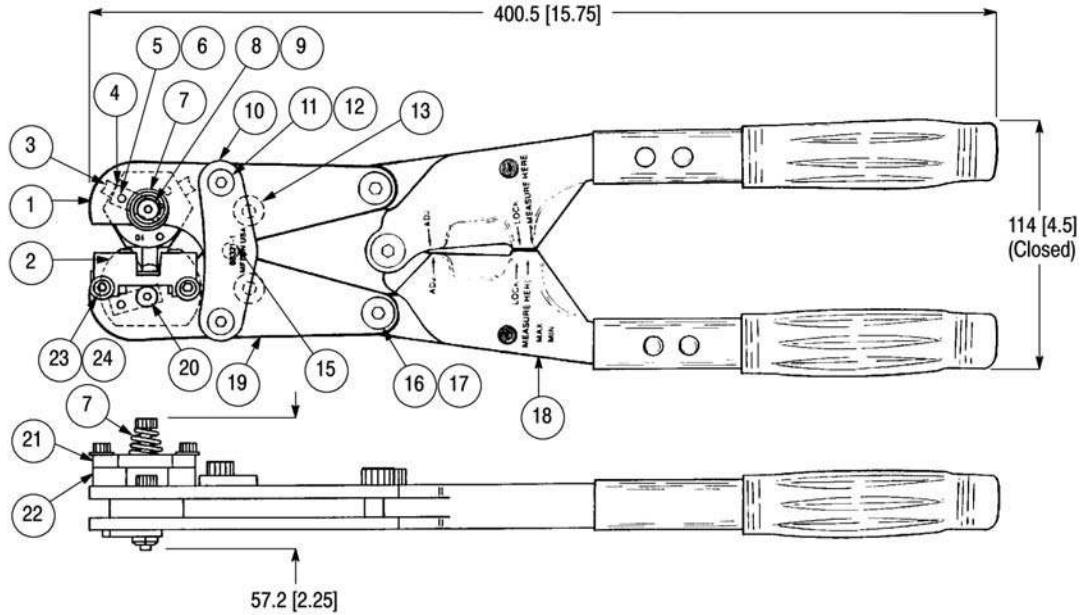

REPLACEMENT PARTS

ITEM	PART NUMBER	DESCRIPTION	QTY PER TOOL
1	308990-1	PLATE, Side	3
2	308991-1	INDENTER	1
3	308992-1	ANVIL	1
4	601088	PLATE, Index	2
5	601089	PIN, Index	2
6	600091	RING, Retaining	2
7	601093	SPRING	1
8	21004-6	SCREW, Shoulder, .25 in. Dia x 1.25 in. L	1
9	1-21002-0	LOCKNUT, 10 x 24	2
10	601082	PLATE, Tie	2
11	1-21004-2	SCREW, Shoulder, .31 in. Dia x 1.00 in. L	2
12	21021-5	LOCKNUT, .25 in. x 20	2
13	600866-1	SPACER	2
14	601086	PIN, Aligning	1
15	1-21004-9	SCREW, Shoulder, .28 in. Dia. x .62 in. L	2
16	21021-6	LOCKNUT, .79 in. x 18	2
17	601078	ASSEMBLY, Handle	1
18	308990-2	PLATE, Side	1
19	21004-3	SCREW, Shoulder, .25 in. Dia x .62 in. L	1
20	314224-1	LOCATOR, Terminal	1
21	314225-1	TERMINAL, Hold Down	1
22	2-21000-9	SCREW, Socket Head, 8-32 x .75 in. L	2
23	21055-6	WASHER, Flat	2

Figure 10