

Automotive Qualified 140Mb/s Bi-directional Level Translator for Push-Pull Applications

Features

- Qualified for Automotive Applications
- AEC-Q100 Qualified with the Following Results
 - Device Temperature Grade 1: -40°C to +125°C Ambient Operating Temperature Range
- 0.9V to 2.0V on A Port and 1.65V to 3.6V on B Port
- VCCA may be greater than, equal to, or less than VCCB
- High-Speed with 140 Mb/s Guaranteed Data Rate
- 100 pF Capacitive Drive Capability
- Low Bit-to-Bit Skew
- Overvoltage Tolerant Enable and I/O Pins
- Non-preferential Power-Up Sequencing
- Power-Off Protection
- Totally Lead-Free & Fully RoHS Compliant (Notes 1 & 2)
- Halogen and Antimony Free. “Green” Device (Note 3)
- The PI4ULS3V304AQ is suitable for automotive applications requiring specific change control; this part is AEC-Q 100 qualified, PPAP capable, and manufactured in IATF 16949 certified facilities.
<https://www.diodes.com/quality/product-definitions/>
- Package: UQFN-12(ZMA)

Applications

- Mobile Phones, PDAs
- Other Portable Devices
- Automotive

Description

The PI4ULS3V304AQ is an automotive qualified 4-bit configurable dual-supply autosensing bidirectional level translator that does not require a direction control pin. The B and A ports are designed to track two different power supply rails, VCCB and VCCA respectively.

The PI4ULS3V304AQ offers the feature that the values of the VCCB and VCCA supplies are independent. Design flexibility is maximized because VCCA can be set to a value either greater than or less than the VCCB supply.

The PI4ULS3V304AQ has high output current capability, which allows the translator to drive high capacitive loads such as most high frequency EMI filters. Another feature of the PI4ULS3V304AQ is that each An and Bn channel can function as either an input or an output.

An Output Enable (EN) input is available to reduce the power consumption. The EN pin can be used to disable both I/O ports by putting them in 3-state which significantly reduces the supply current.

The PI4ULS3V304AQ is capable of 2 kV System-Level ESD.

Block Diagram

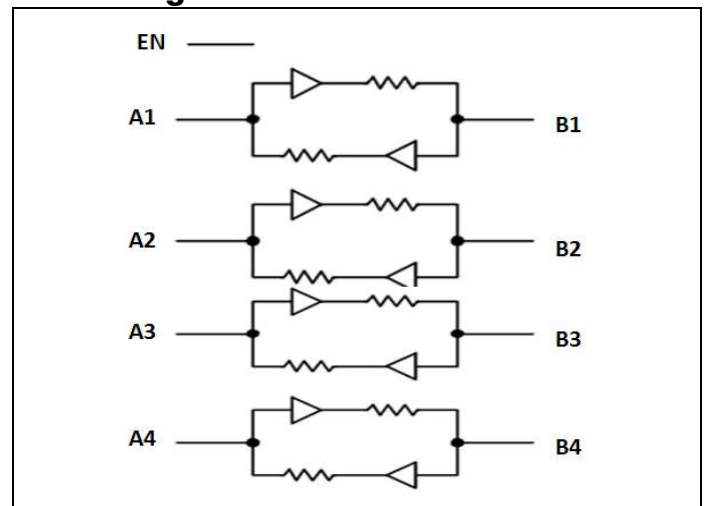
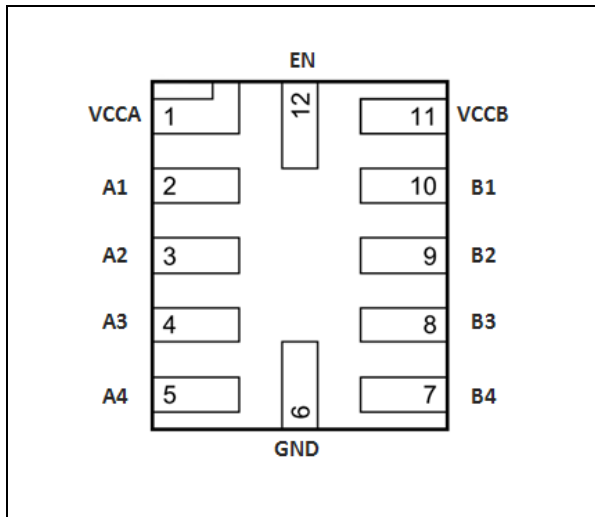

Figure 1: Block Diagram

Notes:
 1. No purposely added lead. Fully EU Directive 2002/95/EC (RoHS), 2011/65/EU (RoHS 2) & 2015/863/EU (RoHS 3) compliant.
 2. See <https://www.diodes.com/quality/lead-free/> for more information about Diodes Incorporated’s definitions of Halogen- and Antimony-free, “Green” and Lead-free.
 3. Halogen- and Antimony-free “Green” products are defined as those which contain <900ppm bromine, <900ppm chlorine (<1500ppm total Br + Cl) and <1000ppm antimony compounds.

Pin Configuration



UQFN (Top View)

Pin Description

Pin#	Pin Name	Type	Description
1	VCCA	Power	A-port supply voltage. $0.9V \leq VCCA \leq 2.0V$
2	A1	I/O	Input/output A. Referenced to VCCA.
3	A2	I/O	Input/output A. Referenced to VCCA
4	A3	I/O	Input/output A. Referenced to VCCA.
5	A4	I/O	Input/output A. Referenced to VCCA
6	GND	GND	Ground.
7	B4	I/O	Input/output B. Referenced to VCCB
8	B3	I/O	Input/output B. Referenced to VCCB
9	B2	I/O	Input/output B. Referenced to VCCB
10	B1	I/O	Input/output B. Referenced to VCCB
11	VCCB	Power	B-port supply voltage. $1.65V \leq VCCB \leq 3.6V$
12	EN	Input	Output enable (active High). Pull EN low to place all outputs in 3-state mode.

Maximum Ratings

Storage Temperature	-65°C to +150°C
Junction Temperature, T _j	125°C
DC Supply Voltage port B	-0.5V to +4.0V
DC Supply Voltage port A	-0.5V to +2.6V
V _i (A) referenced DC Input / Output Voltage	-0.5V to +2.6V
V _i (B) referenced DC Input / Output Voltage	-0.5V to +4.0V
Enable Control Pin DC Input Voltage	-0.5V to +2.6V
DC Input Diode Current (V _I < GND)	-50mA
DC Output Diode Current (V _O < GND)	-50mA
DC Supply Current through V _{CCB}	±100mA
DC Supply Current through V _{CCA}	±100mA
DC Ground Current through Ground Pin	±100mA

Note:

Stresses greater than those listed under MAXIMUM RATINGS may cause permanent damage to the device. This is a stress rating only and functional operation of the device at these or any other conditions above those indicated in the operational sections of this specification is not implied. Exposure to absolute maximum rating conditions for extended periods may affect reliability.

Recommended Operation Conditions

Symbol	Parameter	Min.	Typ.	Max.	Unit
V _{CCA}	A-side Positive DC Supply Voltage	0.9	—	2.0	V
V _{CCB}	B-side Positive DC Supply Voltage	1.65	—	3.6	V
V _I	Enable Control Pin Voltage	GND	—	2.0	V
V _{IO}	Bus Input/Output Pin Voltage	I/O A	—	2.0	V
		I/O B	—	3.6	V
T _A	Operating Temperature Range	-40	—	+125	°C
At/Av	Input Transition Rise or Rate, V _I , V _{IO} from 30% to 70% of V _{CC} ; V _{CC} =3.3 V ± 0.3 V	0	—	10	ns

DC Electrical Characteristics

Symbol	Parameter	Test Conditions *1	V _{CCB} *2 (V)	V _{CCA} *3 (V)	-40°C to +125°C			Unit
					Min.	Typ. *4	Max.	
V _{IHB}	B port Input HIGH Voltage	—	1.65-3.6	0.9-2.0	2/3*V _{CCB}	—	—	V
V _{ILB}	B port Input LOW Voltage	—	1.65-3.6	0.9-2.0	—	—	1/3*V _{CCB}	V
V _{IHA}	A port Input HIGH Voltage	—	1.65-3.6	0.9-1.1	3/4*V _{CCA}	—	—	V
			1.65-3.6	1.1-2.0	2/3*V _{CCA}	—	—	
V _{ILA}	A port Input LOW Voltage	—	1.65-3.6	0.9-1.1	—	—	1/4*V _{CCA}	V
			1.65-3.6	1.1-2.0	—	—	1/3*V _{CCA}	
V _{IH}	Control Pin Input HIGH Voltage	—	1.65-3.6	0.9-1.1	3/4*V _{CCA}	—	—	V
			1.65-3.6	1.1-2.0	2/3*V _{CCA}	—	—	V
V _{IL}	Control Pin Input LOW Voltage	—	1.65-3.6	0.9-1.1	—	—	1/4*V _{CCA}	V
			1.65-3.6	1.1-2.0	—	—	1/3*V _{CCA}	V
V _{OHB}	B port Output HIGH Voltage	B port source current = 20μA	1.65-3.6	0.9-2.0	0.9*V _{CCB}	—	—	V
V _{OLB}	B port Output LOW Voltage	B port sink current = 20μA	1.65-3.6	0.9-2.0	—	—	0.2	V
V _{OHA}	A port Output HIGH Voltage	A port source current = 20μA	1.65-3.6	0.9-2.0	0.9*V _{CCA}	—	—	V
V _{OLA}	A port Output LOW Voltage	A port sink current = 20μA	1.65-3.6	0.9-2.0	—	—	0.2	V
I _{QVB}	V _{CCB} Supply Current	EN = V _{CCA} , I _O = 0A, (I/O _B = 0V or V _{CCB} , I/O _A = float) or (I/O _B = float, I/O _A = 0V or V _{CCA})	1.65-3.6	0.9-2.0	—	0.1	6	μA
I _{QVA}	V _{CCA} Supply Current		1.65-3.6	0.9-2.0	—	0.2	30	μA
I _{TS-B}	B port Tristate Output Mode Supply Current	EN=0V (I/O _B = 0V or V _{CCB} , I/O _A = float) or (I/O _B = float, I/O _A = 0V or V _{CCA})	1.65-3.6	0.9-2.0	—	0.1	6	μA
I _{TS-A}	A port Tristate Output Mode Supply Current		1.65-3.6	0.9-2.0	—	0.2	30	μA
I _{OZ}	I/O Tristate Output Mode Leakage Current	EN= 0V	1.65-3.6	0.9-2.0	—	—	±6	μA
I _I	Control Pin Input Current	—	1.65-3.6	0.9-2.0	—	—	±1	μA
I _{OFF}	Power Off Leakage Current	I/O _B = 0 to 3.6V, I/O _A = 0 to 2.0V	0	0	—	—	15	μA
			1.65-3.6	0	—	—	30	
			0	0.9-2.0	—	—	15	

Note:

- Normal test conditions are V_I = 0V, C_{IOB} ≤ 15pF and C_{IOA} ≤ 15pF, unless otherwise specified.
- V_{CCB} is the supply voltage associated with the I/O B port, and B range from +1.65 V to 3.6 V under normal operating conditions.
- V_{CCA} is the supply voltage associated with the I/O A port, and A range from +0.9 V to 2.0V under normal operating conditions.
- Typical values are tested at T_A = +25°C. Limits over the operating temperature range are guaranteed by design.
- When V_{CCA} < 1.0V, V_{IH} is 0.75*V_{CCA} (Min), V_{IL} is 0.25*V_{CCA} (Max)

Timing Characteristics

Symbol	Parameter	Test Conditions *1	V _{CCB} *2 (V)	V _{CCA} *3(V)	-40°C to +125°C			Unit
					Min.	Typ. *4	Max.	
t _{R-B}	B port Rise Time	C _{IOB} = 15 pF	1.65-3.6	0.9-2.0	—	3	8	ns
			2.25-3.6	1.65-2.0	—	0.8	4	
t _{F-B}	B port Fall Time	C _{IOB} = 15 pF	1.65-3.6	0.9-2.0	—	0.6	3	ns
			2.25-3.6	1.65-2.0	—	0.5	3	
t _{R-A}	A port Rise Time	C _{IOA} = 15 pF	1.65-3.6	0.9-2.0	—	4	12	ns
			2.25-3.6	1.65-2.0	—	0.7	4	
t _{F-A}	A port Fall Time	C _{IOA} = 15 pF	1.65-3.6	0.9-2.0	—	0.8	4	ns
			2.25-3.6	1.65-2.0	—	0.5	3	
Z _{OB}	B port One-Shot Output Impedance	*5	1.8	0.9-2.0	—	37	—	Ω
			2.5			20	—	
			3.6			15	—	
Z _{OA}	A port One-Shot Out-put Impedance	*5	1.8-3.3	0.9	—	52	—	Ω
				1.8		17	—	
				2.0		15	—	
t _{PD,A-B}	Propagation Delay (Driving B port)	C _{IOB} = 15 pF	1.65-3.6	0.9-2.0	—	9.8	35	ns
			2.25-3.6	1.65-2.0	—	2.3	10	
		C _{IOB} = 30 pF	1.65-3.6	0.9-2.0	—	10	35	
			2.25-3.6	1.65-2.0	—	2.5	10	
		C _{IOB} = 50 pF	1.65-3.6	0.9-2.0	—	10.4	37	
			2.25-3.6	1.65-2.0	—	2.7	11	
t _{PD,B-A}	Propagation Delay (Driving A port)	C _{IOA} = 15 pF	1.65-3.6	0.9-2.0	—	9.4	35	ns
			2.25-3.6	1.65-2.0	—	1.6	10	
		C _{IOA} = 30 pF	1.65-3.6	0.9-2.0	—	9.6	35	
			2.25-3.6	1.65-2.0	—	1.8	10	
		C _{IOA} = 50 pF	1.65-3.6	0.9-2.0	—	10	37	
			2.25-3.6	1.65-2.0	—	2	11	
C _{IOA} = 100 pF	1.65-3.6	0.9-2.0	—	11.2	40			
	2.25-3.6	1.65-2.0	—	2.6	13			
t _{SK}	Channel-to-Channel Skew	C _{IOB} = 15pF, C _{IOA} = 15pF*5	1.65-3.6	0.9-2.0	—	-	0.15	ns
t _{EN-B} (t _{PZH})	B port Output Enable Time	C _{IOB} = 15pF, I/O_A = V _{CCA}	1.65-3.6	0.9-2.0	—	120	250	ns
			2.25-3.6	1.65-2.0	—	40	160	
t _{EN-B} (t _{PZL})		C _{IOB} = 15pF, I/O_A = 0V	1.65-3.6	0.9-2.0	—	80	200	
			2.25-3.6	1.65-2.0	—	40	160	
t _{EN-A} (t _{PZH})	A port Output Enable Time	C _{IOA} = 15pF, I/O_B = V _{CCB}	1.65-3.6	0.9-2.0	—	120	250	ns
			2.25-3.6	1.65-2.0	—	40	160	
t _{EN-A} (t _{PZL})		C _{IOA} = 15 pF, I/O_B = 0 V	1.65-3.6	0.9-2.0	—	50	200	
			2.25-3.6	1.65-2.0	—	30	160	
t _{DIS-B} (t _{PHZ})	B port Output Disable Time	C _{IOB} = 15pF, I/O_A = V _{CCA}	1.65-3.6	0.9-2.0	—	200	400	ns
			2.25-3.6	1.65-2.0	—	200	400	
t _{DIS-B} (t _{PLZ})		C _{IOB} = 15pF, I/O_A = 0V	1.65-3.6	0.9-2.0	—	60	175	
			2.25-3.6	1.65-2.0	—	60	175	
t _{DIS-A} (t _{PHZ})	A port Output Disable Time	C _{IOB} = 15pF, I/O_A = V _{CCA}	1.65-3.6	0.9-2.0	—	180	400	ns
			2.25-3.6	1.65-2.0	—	100	400	
t _{DIS-A} (t _{PLZ})		C _{IOB} = 15pF, I/O_A = 0V	1.65-3.6	0.9-2.0	—	50	175	
			2.25-3.6	1.65-2.0	—	50	175	
M _{IDR}	Maximum Data Rate	C _{IO} = 15pF	1.65-3.6	0.9-2.0	50	—	—	mbps
			2.25-3.6	1.65-2.0	140	—	—	
		C _{IO} = 30pF	1.65-3.6	0.9-2.0	40	—	—	
2.25-3.6			1.65-2.0	120	—	—		
C _{IO} = 50pF		1.65-3.6	0.9-2.0	30	—	—		

			2.25-3.6	1.65-2.0	100	—	—	
		$C_{IO} = 100\text{pF}$	1.65-3.6	0.9-2.0	20	—	—	
			2.25-3.6	1.65-2.0	60	—	—	

Notes:

1. Normal test conditions are $V_I = 0\text{ V}$, $C_{IOB} \leq 15\text{pF}$ and $C_{IOA} \leq 15\text{pF}$, unless otherwise specified.
2. V_{CCB} is the supply voltage associated with the I/O B port, and B ranges from +1.65 V to 3.6 V under normal operating conditions.
3. V_{CCA} is the supply voltage associated with the I/O A port, and A ranges from +0.9 V to 2.0V under normal operating conditions.
4. Typical values are tested at $T_A = +25^\circ\text{C}$. Limits over the operating temperature range are guaranteed by design.
5. Guaranteed by design

Power Consumption ($T_A = +25^\circ\text{C}$)

Symbol ⁽¹⁾	Parameter	Test Conditions	V _{CCB} ^{*2} (V)	V _{CCA} ^{*3} (V)	Typ.	Unit
C _{PD_VCCA}	A = Input port, B = Output Port	C _{Load} = 0, f = 1MHz, EN = V _{CCA} (outputs enabled)	1.65-3.6	0.9-2.0	40	pF
	B = Input port, A = Output Port					
C _{PD_VCCB}	A = Input port, B = Output Port	C _{Load} = 0, f = 1MHz, EN = V _{CCA} (outputs enabled)	1.65-3.6	0.9-2.0	40	pF
	B = Input port, A = Output Port					
C _{PD_VCCA}	A = Input port, B = Output Port	C _{Load} = 0, f = 1MHz, EN = GND(outputs disabled)	1.65-3.6	0.9-2.0	1	pF
	B = Input port, A = Output Port					
C _{PD_VCCB}	A = Input port, B = Output Port	C _{Load} = 0, f = 1MHz, EN = GND(outputs disabled)	1.65-3.6	0.9-2.0	1	pF
	B = Input port, A = Output Port					

Notes:

1. C_{PD_VCCA} and C_{PD_VCCB} are defined as the value of the IC's equivalent capacitance from which the operating current can be calculated for the A and B power supplies, respectively. $I_{CC} = I_{CC}(\text{dynamic}) + I_{CC}(\text{static}) \approx I_{CC}(\text{operating}) \approx CPD \times V_{CC} \times f_{IN} \times NSW$ where $I_{CC} = I_{CC_VCCB} + I_{CC_VCCA}$ and NSW = total number of outputs switching.
2. V_{CCB} is the supply voltage associated with the I/O B port, and V_{CCB} ranges from +1.65V to 3.6V under normal operating conditions.
3. V_{CCA} is the supply voltage associated with the I/O A port, and V_{CCA} range from +0.9 V to 2.0V under normal operating conditions.
4. Typical values are tested at T_A = +25°C. Limits over the operating temperature range are guaranteed by design.

Test Circuits

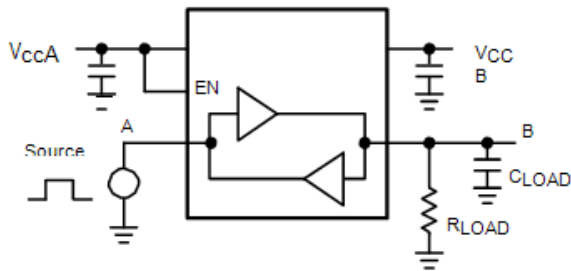

Figure 2. Driving A Test Circuit

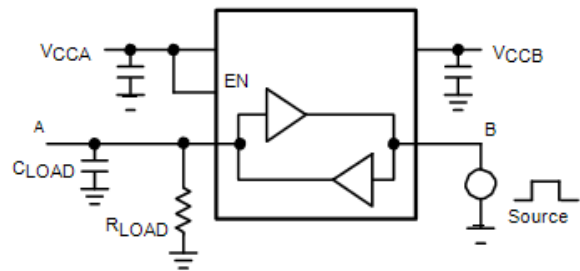

Figure 3. Driving B Test Circuit

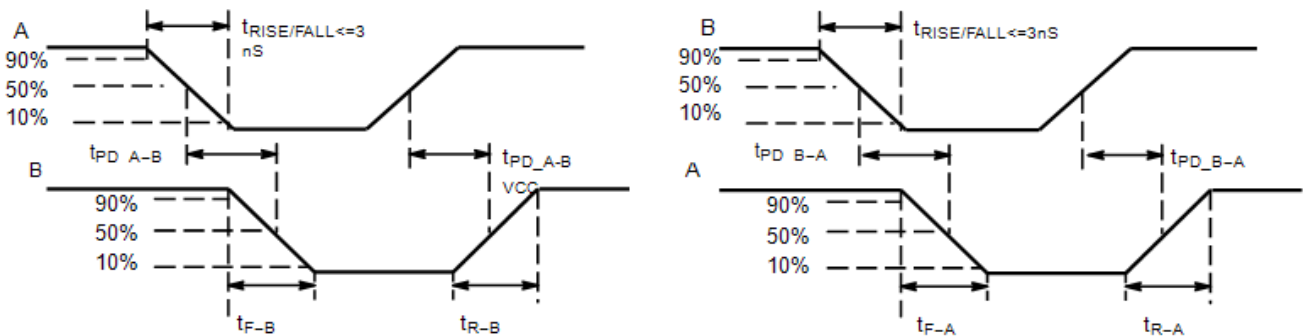
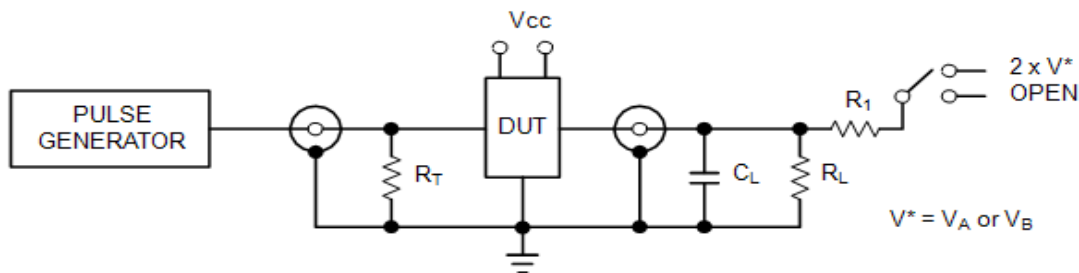

Figure 4. Definition of Timing Specification Parameters



Test	Switch
t_{PZH}, t_{PHZ}	Open
t_{PZL}, t_{PLZ}	$2 \times V^*$

$C_L = 15 \text{ pF}$ or equivalent (Includes jig and probe capacitance)
 $R_L = R_1 = 50 \text{ k}\Omega$ or equivalent
 $R_T = Z_{OUT}$ of pulse generator (typically 50Ω)
 $V^* = V_A$ or V_B for A or B measurements, respectively.

Figure 5. Test Circuit for Enable/Disable Time Measurement

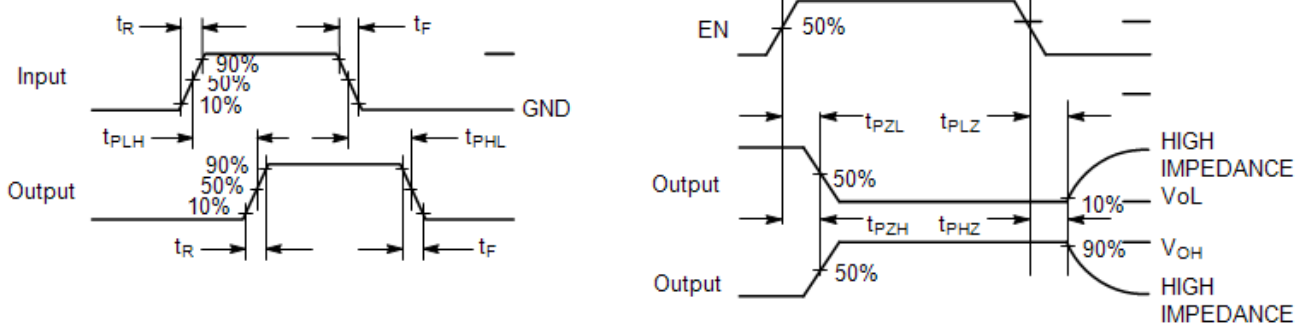

Figure 6. Timing Definitions for Propagation Delays and Enable/Disable Measurement

Functional Description

The PI4ULS3V304AQ is a 4-bit configurable dual-supply autosensing bidirectional level translator that does not require a direction control pin. The B and A ports are designed to track two different power supply rails, VCCB and VCCA respectively.

The PI4ULS3V304AQ offers the feature that the values of the VCCB and VCCA supplies are independent. Design flexibility is maximized because VCCA can be set to a value either greater than or less than the VCCB supply.

The PI4ULS3V304AQ has high output current capability, which allows the translator to drive high capacitive loads such as most high frequency EMI filters. Another feature of the PI4ULS3V304AQ is that each An and Bn channel can function as either an input or an output.

An Output Enable (EN) input is available to reduce the power consumption. The EN pin can be used to disable both I/O ports by putting them in 3-state which significantly reduces the supply current.

Application Information

Level Translator Architecture

The PI4ULS3V304AQ auto-sense translator provides bi-directional logic voltage level shifting to transfer data in multiple supply voltage systems. These level translators have two supply voltages, VCCA and VCCB, which set the logic levels on the input and output sides of the translator. When used to transfer data from the I/O VCCA to the I/O VCCB ports, input signals referenced to the VCCA supply are translated to output signals with a logic level matched to VCCB. In a similar manner, the I/O VCCB to I/O VCCA translation shifts input signals with a logic level compatible to VCCB to an output signal matched to VCCA. The PI4ULS3V304AQ translator consists of bi-directional channels that independently determine the direction of the data flow without requiring a directional pin. One-shot circuits are used to detect the rising or falling input signals. In addition, the one-shots decrease the rise and fall times of the output signal for high-to-low and low-to-high transitions.

Input Driver Requirements

Auto-sense translators such as the PI4ULS3V304AQ have a wide bandwidth, but a relatively small DC output current rating. The high bandwidth of the bi-directional I/O circuit is used to quickly transform from an input to an output driver and vice versa. The I/O ports have a modest DC current output specification so that the output driver can be over driven when data is sent in the opposite direction. For proper operation, the input driver to the auto-sense translator should be capable of driving 3mA of peak output current. The bi-directional configuration of the translator results in both input stages being active for a very short time period. Although the peak current from the input signal circuit is relatively large, the average current is small and consistent with a standard CMOS input stage. Enable Input (EN) The PI4ULS3V304AQ translator has an Enable pin (EN) that provides tri-state operation at the I/O pins. Driving the Enable pin to a low logic level minimizes the power consumption of the device and drives the I/O VCCB and I/O VCCA pins to a high impedance state. Normal translation operation occurs when the EN pin is equal to a logic high signal. The EN pin is referenced to the VCCA supply and has Over-Voltage Tolerant (OVT) protection.

Uni-Directional versus Bi-Directional Translation

The PI4ULS3V304AQ translator can function as a non-inverting uni-directional translator. One advantage of using the translator as a uni-directional device is that each I/O pin can be configured as either an input or output. The configurable input or output

feature is especially useful in applications such as SPI that use multiple uni-directional I/O lines to send data to and from a device. The flexible I/O port of the auto sense translator simplifies the trace connections on the PCB.

Power Supply Guidelines

The values of the V_{CCA} and V_{CCB} supplies can be set to anywhere in range 0.9-2.0V and 1.65-3.6V. Design flexibility is maximized because V_{CCA} may be either greater than or less than the V_{CCB} supply. In contrast, the majority of the competitive auto sense translators has a restriction that the value of the V_{CCA} supply must be equal to less than $(V_{CCB} - 0.4) V$. The sequencing of the power supplies will not damage the device during power-up operation. In addition, the I/O V_{CCB} and I/O V_{CCA} pins are in the high impedance state if either supply voltage is equal to 0V. For optimal performance, 0.01 to 0.1 μ F decoupling capacitors should be used on the V_{CCA} and V_{CCB} power supply pins. Ceramic capacitors are a good design choice to filter and bypass any noise signals on the voltage lines to the ground plane of the PCB. The noise immunity will be maximized by placing the capacitors as close as possible to the supply and ground pins, along with minimizing the PCB connection traces. The PI4ULS3V304AQ translators have a power down feature that provides design flexibility. The output ports are disabled when either power supply is off (V_{CCA} or V_{CCB} = 0V). This feature causes all of the I/O pins to be in the power saving high impedance state.

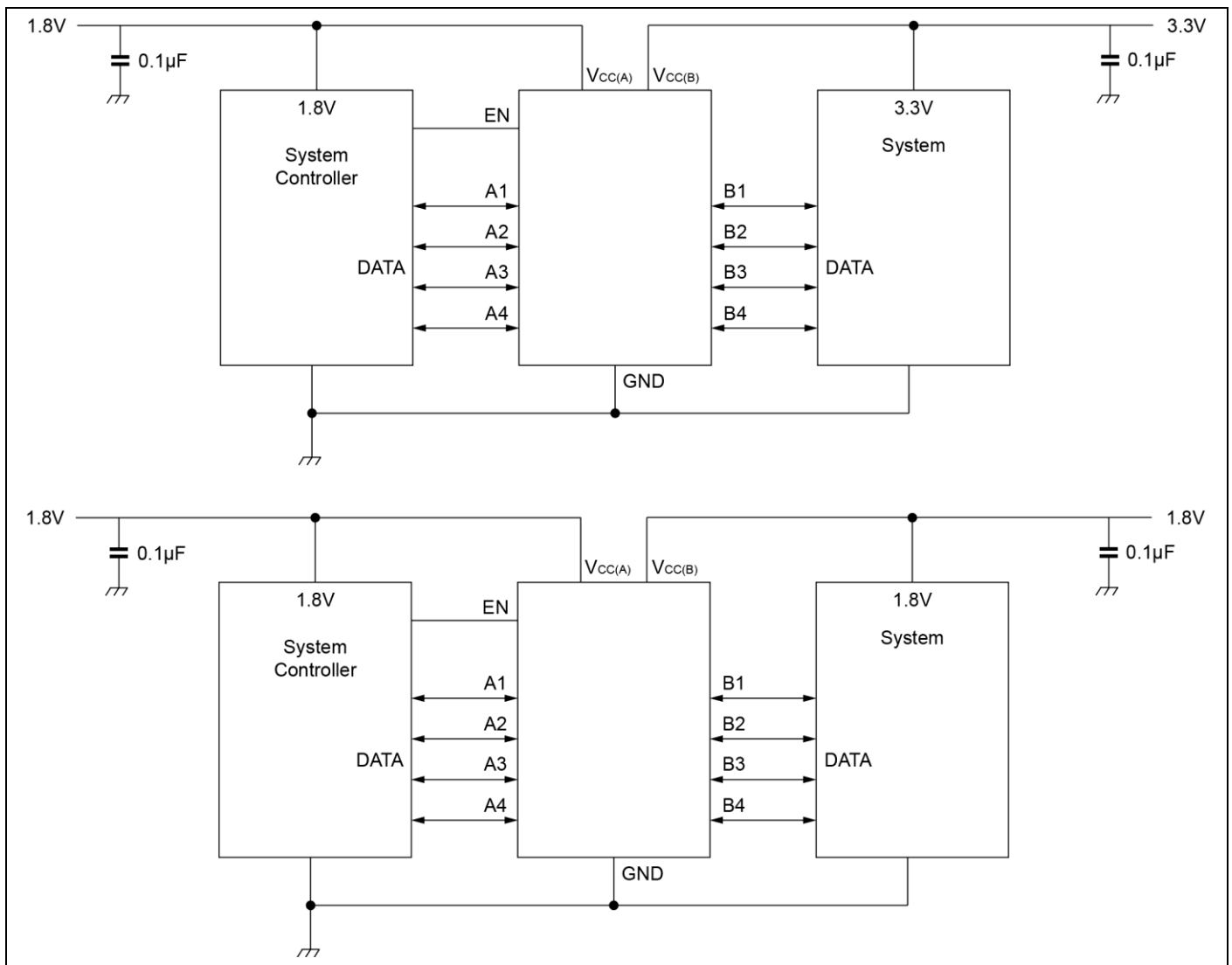
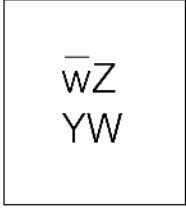

Figure 7. Typical Application

PI4ULS3V304AQ

Part Marking



wZ: PI4ULS3V304AQ1ZMAE
Y: Date Code (Year)
W: Date Code (Workweek)

Packaging Mechanical
UQFN-12 (ZMA)

Package Outline Dimensions

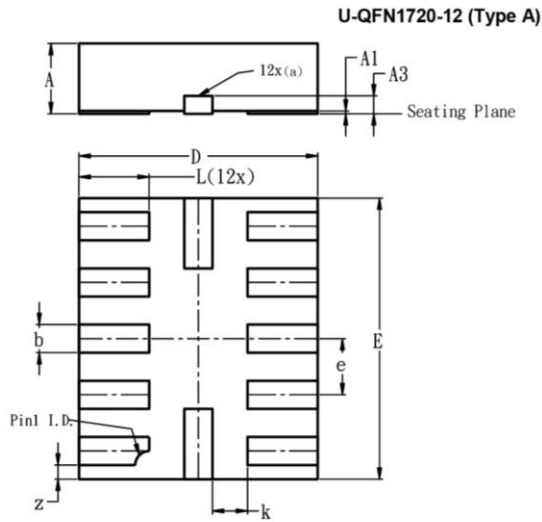

Dim	Min	Max	Typ
A	0.45	0.55	0.50
A1	0.00	0.05	0.02
A3	--	--	0.127
b	0.15	0.25	0.20
D	1.65	1.75	1.70
E	1.95	2.05	2.00
e	0.40 BSC		
L	0.45	0.55	0.50
k	--	--	0.25
z	--	--	0.10
All Dimensions in mm			

Note: (a) Actual shape dependent upon manufacturing technology used.

Suggested Pad Layout

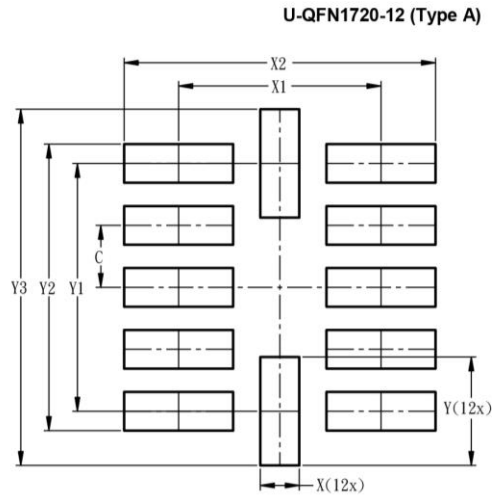

Dimensions	Value (in mm)
C	0.400
X	0.250
X1	1.300
X2	2.000
Y	0.700
Y1	1.600
Y2	1.850
Y3	2.300

For latest package info.

please check: <http://www.diodes.com/design/support/packaging/pericom-packaging/packaging-mechanicals-and-thermal-characteristics/>

Ordering Information

Part Numbers	Package Code	Description
PI4ULS3V304AQ1ZMAEX	ZMA	12-Pin (UQFN)

Notes:

- No purposely added lead. Fully EU Directive 2002/95/EC (RoHS), 2011/65/EU (RoHS 2) & 2015/863/EU (RoHS 3) compliant.
- See <https://www.diodes.com/quality/lead-free/> for more information about Diodes Incorporated's definitions of Halogen- and Antimony-free, "Green" and Lead-free.
- Halogen- and Antimony-free "Green" products are defined as those which contain <900ppm bromine, <900ppm chlorine (<1500ppm total Br + Cl) and <1000ppm antimony compounds.
- Q = Automotive Compliant
- 1 = AEC-Q100 Grade Level
- E = Pb-free and Green
- X suffix = Tape/Reel

IMPORTANT NOTICE

DIODES INCORPORATED MAKES NO WARRANTY OF ANY KIND, EXPRESS OR IMPLIED, WITH REGARDS TO THIS DOCUMENT, INCLUDING, BUT NOT LIMITED TO, THE IMPLIED WARRANTIES OF MERCHANTABILITY AND FITNESS FOR A PARTICULAR PURPOSE (AND THEIR EQUIVALENTS UNDER THE LAWS OF ANY JURISDICTION).

Diodes Incorporated and its subsidiaries reserve the right to make modifications, enhancements, improvements, corrections or other changes without further notice to this document and any product described herein. Diodes Incorporated does not assume any liability arising out of the application or use of this document or any product described herein; neither does Diodes Incorporated convey any license under its patent or trademark rights, nor the rights of others. Any Customer or user of this document or products described herein in such applications shall assume all risks of such use and will agree to hold Diodes Incorporated and all the companies whose products are represented on Diodes Incorporated website, harmless against all damages.

Diodes Incorporated does not warrant or accept any liability whatsoever in respect of any products purchased through unauthorized sales channel.

Should Customers purchase or use Diodes Incorporated products for any unintended or unauthorized application, Customers shall indemnify and hold Diodes Incorporated and its representatives harmless against all claims, damages, expenses, and attorney fees arising out of, directly or indirectly, any claim of personal injury or death associated with such unintended or unauthorized application.

Products described herein may be covered by one or more United States, international or foreign patents pending. Product names and markings noted herein may also be covered by one or more United States, international or foreign trademarks.

This document is written in English but may be translated into multiple languages for reference. Only the English version of this document is the final and determinative format released by Diodes Incorporated.

LIFE SUPPORT

Diodes Incorporated products are specifically not authorized for use as critical components in life support devices or systems without the express written approval of the Chief Executive Officer of Diodes Incorporated. As used herein:

A. Life support devices or systems are devices or systems which:

1. are intended to implant into the body, or
2. support or sustain life and whose failure to perform when properly used in accordance with instructions for use provided in the labeling can be reasonably expected to result in significant injury to the user.

B. A critical component is any component in a life support device or system whose failure to perform can be reasonably expected to cause the failure of the life support device or to affect its safety or effectiveness.

Customers represent that they have all necessary expertise in the safety and regulatory ramifications of their life support devices or systems, and acknowledge and agree that they are solely responsible for all legal, regulatory and safety-related requirements concerning their products and any use of Diodes Incorporated products in such safety-critical, life support devices or systems, notwithstanding any devices- or systems-related information or support that may be provided by Diodes Incorporated. Further, Customers must fully indemnify Diodes Incorporated and its representatives against any damages arising out of the use of Diodes Incorporated products in such safety-critical, life support devices or systems.

Copyright © 2020, Diodes Incorporated
www.diodes.com