

| PART NUMBER | REVISION | DESCRIPTION | FEED TYPE |
|-------------|----------|----------------------------------|------------|
| 2151125-1 | E | FINE CRIMP HEIGHT ADJUST | MECHANICAL |
| 2151125-2 | E | FINE CRIMP HEIGHT ADJUST | PNEUMATIC |
| 7-2151125-1 | E | MECHANICAL AND CRIMP TOOLING KIT | MECHANICAL |
| 7-2151125-2 | E | PNEUMATIC AND CRIMP TOOLING KIT | PNEUMATIC |
| 7-2151125-7 | A | CRIMP TOOLING KIT | - |

ATLANTIC VERSION TERMINATOR INTERFACE ADAPTER



| APPLICATOR DATA | | |
|-----------------|----------------|------|
| CRIMP | SIZE | TYPE |
| WIRE | 1.78 mm [.070] | F |
| INSUL | 2.00 mm [.079] | BX |

APPLICATOR INSTRUCTIONS 408-35042

| TERMINAL DATA: TE TERMINAL | | TE CRIMP SPECIFICATION | |
|---------------------------------------|---------------|------------------------------|--------------|
| TERMINAL NAME: 070 SERIES TAB CONTACT | | | |
| WIRE STRIP LENGTH | | INSULATION DIAMETER RANGE | |
| 3.50-4.50 mm [.138-.177 IN] | | Ø1.40-1.90 mm [.055-.075 IN] | |
| TERMINAL APPLICATION SPECIFICATION | (A)114-5092 | | |
| | (B)114-5092-3 | | |
| TERMINALS APPLIED | | | |
| TE TERMINAL | TE TERMINAL | TE TERMINAL | TE TERMINAL |
| (A) 173633-1 | (A) 173633-2 | (A) 173633-3 | (A) 173633-4 |
| (B) 175188-1 | | | |

| WIRE SIZE | CRIMP HEIGHT mm [INCH] | CRIMP HEIGHT REFERENCE SETTING |
|-----------|----------------------------|--------------------------------|
| 0.30mm2 | 1.03+/-0.05 [.041+/- .002] | 7.9 |
| 0.20mm2 | 0.96+/-0.05 [.038+/- .002] | 8.8 |

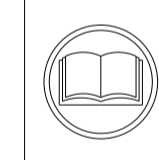

- RECOMMENDED SPARE PARTS
- REFER TO SUPPLIED INSTRUCTION SHEET FOR CLEANING, LUBRICATION AND STORAGE OF APPLICATOR.
- APPLY PART NUMBER 2-23419-6 LOCTITE TO THREADS OF ITEM 242.
- CRIMP HEIGHT REFERENCE SETTING WAS THE SETTING USED WHEN THE APPLICATOR WAS QUALIFIED AT THE FACTORY. ADJUSTMENT MAY BE NECESSARY WHEN RUNNING APPLICATOR IN THE FIELD.
- UNLESS SPECIFIED OTHERWISE TORQUE VALUES SHALL BE USED PER DOCUMENT, 101-35000.

***WARNING**
ON INSTALLATION, SET WIRE DISC TO CRIMP HEIGHT REFERENCE SETTING FOR LARGEST WIRE SIZE. CRIMP HEIGHT REFERENCE SETTINGS GREATER THAN THE VALUE SHOWN MAY CAUSE DAMAGE TO THE CRIMP TOOLING. REFER TO THE INSTRUCTION SHEET FOR PROPER SETUP AND ADJUSTMENTS.

| LOC | DIST | REVISIONS | | | | | |
|-----|------|-----------|-----|---------------|-----------|-----|------|
| | | P | LTN | DESCRIPTION | DATE | OWN | APVD |
| A | 66 | B | | ECR-16-004345 | 24MAR2016 | XZ | LZ |
| | | C | | ECR-18-007382 | 15MAY2018 | TB | JDG |
| | | D | | ECR-20-013375 | 21SEP2020 | FJ | TE |
| | | E | | ECR-22-161361 | 15DEC2022 | FZ | JAH |

| | | | | | | | |
|---|-----|-----|-----|-----|-------------|-------------------------------------|-----|
| - | 1 | - | 1 | - | 2119641-1 | FEED CAM, AIR FEED | 248 |
| - | 1 | 1 | 1 | 1 | 2119082-7 | CAM, SNAIL, INSULATION ADJUSTMENT | 244 |
| - | 1 | 1 | 1 | 1 | 2079764-1 | WASHER, WAVE SPRING, CREST-TO-CREST | 243 |
| - | 1 | 1 | 1 | 1 | 2119083-1 | RETAINER, INSULATION DIAL | 242 |
| - | 1 | 1 | 1 | 1 | 7-18023-7 | SCR, SKT HD CAP M3 X 4.0 | 241 |
| - | - | 1 | - | 1 | 2119580-1 | MECHANICAL FEED ASSEMBLY | 239 |
| - | 1 | - | 1 | - | 2844940-1 | AIR FEED MODULE | 238 |
| - | REF | REF | REF | REF | 994970-2 | COUNTER, MAGNETIC | 164 |
| - | 1 | 1 | 1 | 1 | 1-18028-2 | WASHER, FLAT, REG M4 | 119 |
| - | 1 | 1 | 1 | 1 | 2844908-1 | SCREW, LOCKING | 99 |
| - | 1 | 1 | 1 | 1 | 2844907-1 | POST, LOCKING | 98 |
| - | 1 | 1 | 1 | 1 | 455888-3 | SPACER, CRIMPER | 82 |
| - | 1 | 1 | 1 | 1 | 1803607-3 | DOCUMENTATION PACKAGE | 71 |
| - | 1 | 1 | 1 | 1 | 2119791-9 | DEPRESSOR, WIRE | 70 |
| - | 1 | 1 | 1 | 1 | 2119740-1 | TAG, IDENTIFICATION | 67 |
| - | 2 | 2 | 2 | 2 | 2168078-1 | SCREW, DRIVE, RH, RoHS, 2 x .188 | 66 |
| - | 1 | 1 | 1 | 1 | 2168083-2 | SCR, SKT HD CAP, RoHS, M4 X 8.0 | 60 |
| - | 1 | 1 | 1 | 1 | 5-18022-5 | SCR, HEX HD CAP, M4 X 6.0 | 59 |
| - | 1 | 1 | 1 | 1 | 1338685-1 | PAWL, FEED | 56 |
| - | 4 | 4 | 4 | 4 | 2168083-3 | SCR, SKT HD CAP, RoHS, M4 X 12.0 | 54 |
| - | 2 | 2 | 2 | 2 | 2-2168083-5 | SCR, SKT HD CAP, RoHS, M4 X 14 | 53 |
| - | 1 | 1 | 1 | 1 | 1803382-6 | HOLD DOWN, SPRING LOADED | 50 |
| - | 1 | 2 | 1 | 2 | 18023-9 | SCR, SKT HD CAP M4 X 6.0 | 49 |
| - | - | 1 | - | 1 | 2119652-1 | FEED CAM, PRE FEED | 48 |
| - | - | 1 | - | 1 | 2119653-1 | FEED CAM, POST FEED | 47 |
| - | 1 | 1 | 1 | 1 | 1803583-9 | APPLICATOR BASIC ASSEMBLY, SF | 46 |
| - | 1 | 1 | 1 | 1 | 1803515-1 | RAM ASSEMBLY, SF ATLANTIC | 44 |
| - | 1 | 1 | 1 | 1 | 1803602-1 | SCR, BHSC, RoHS (M8 X 25) | 41 |
| - | 1 | 1 | 1 | 1 | 1752356-1 | SUPPORT, TERMINAL | 34 |
| - | 2 | 2 | 2 | 2 | 2079383-5 | SCR, BHSC, RoHS (M4 X 20) | 33 |
| - | 2 | 2 | 2 | 2 | 2-2844962-8 | SPACER, CYLINDRICAL, STRIP GUIDE | 30 |
| - | 1 | 1 | 1 | 1 | 2844992-1 | ASSEMBLY, STRIP GUIDE | 29 |
| - | 1 | 1 | 1 | 1 | 1320928-2 | STRIP GUIDE | 24 |
| - | 1 | 1 | 1 | 1 | 2168083-2 | SCR, SKT HD CAP, RoHS, M4 X 8.0 | 21 |
| - | 1 | 1 | 1 | 1 | 1-18028-2 | WASHER, FLAT, REG M4 | 20 |
| - | 1 | 1 | 1 | 1 | 2119533-1 | STRIPPER, SIDE FEED | 19 |
| - | 1 | 1 | 1 | 1 | 2119806-1 | INSERT, SHEAR | 13 |
| - | 1 | 1 | 1 | 1 | 3-22280-3 | SPRING, COMPRESSION | 12 |
| - | 1 | 1 | 1 | 1 | 1-356885-4 | STOP, SHEAR | 11 |
| - | 1 | 1 | 1 | 1 | 2119805-1 | SHEAR HOLDER, FRONT | 10 |
| - | 1 | 1 | 1 | 1 | 1803095-3 | FLOATING SHEAR, FRONT | 9 |
| - | 1 | 2 | 2 | 1 | 1333203-9 | ANVIL, COMBINATION | 8 |
| - | 1 | 1 | 1 | 1 | 240641-4 | SPACER | 7 |
| - | 1 | 1 | 1 | 1 | 2119757-8 | DEPRESSOR, SHEAR | 5 |
| - | 1 | 1 | 1 | 1 | 238011-4 | BLOCK, CRIMPER SPACER | 4 |
| - | 1 | 2 | 2 | 1 | 1633988-2 | CRIMPER, INSULATION BOX PREMIUM | 3 |
| - | 1 | 1 | 1 | 1 | 455888-3 | SPACER, CRIMPER | 2 |
| - | 1 | 2 | 2 | 1 | 3-456404-5 | CRIMPER, WIRE PREMIUM | 1 |

ATLANTIC VERSION
Shown on sheets 1 of 4 & 2 of 4
(Pacific version shown on sheets 3 of 4 & 4 of 4)

| DIMENSIONS: | | TOLERANCES UNLESS OTHERWISE SPECIFIED: | | MATERIAL: | | FINISH: | |
|-------------|---------|--|---------|-----------|---------|----------|----------|
| mm | 0 PLC ± | 1 PLC ± | 2 PLC ± | 3 PLC ± | 4 PLC ± | ANGLES ± | FINISH ± |

| ITEM NO | PART NO | DESCRIPTION | | | |
|---------|---------|-------------|----|----|--|
| -77 | -72 | -71 | -2 | -1 | |

| CHK | DATE | NAME |
|----------|-----------|------|
| H. HUANG | 08OCT2011 | |
| S. XI | 08OCT2011 | |
| J. CRUZ | 08OCT2011 | |

| SIZE | CAGE CODE | DRAWING NO | RESTRICTED TO |
|------|-----------|------------|---------------|
| A1 | 00779 | 2151125 | |

Customer Accessible Production Drawing SCALE 1:2 SHEET 1 OF 4 REV E

| LOC | DIST | REVISIONS | | | |
|-----|-------------|-----------|------|----|------|
| A | 66 | REV | DATE | BY | APPV |
| - | SEE SHEET 1 | - | - | - | - |

FEED TYPE MECHANICAL

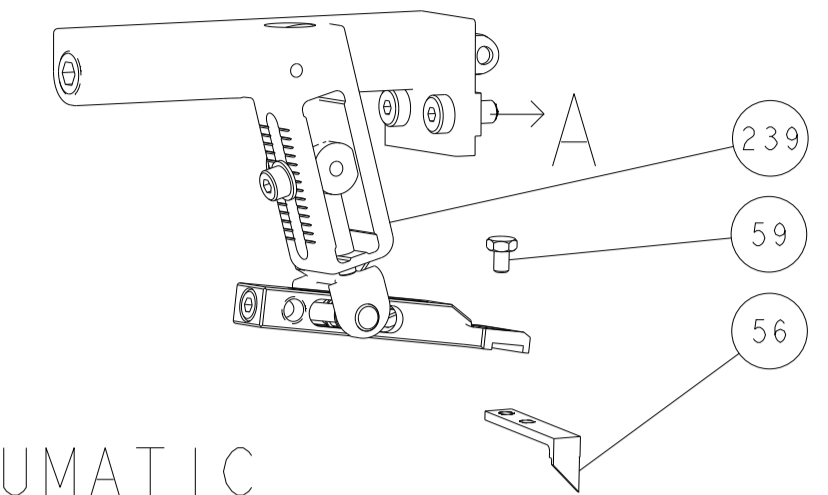

PNEUMATIC

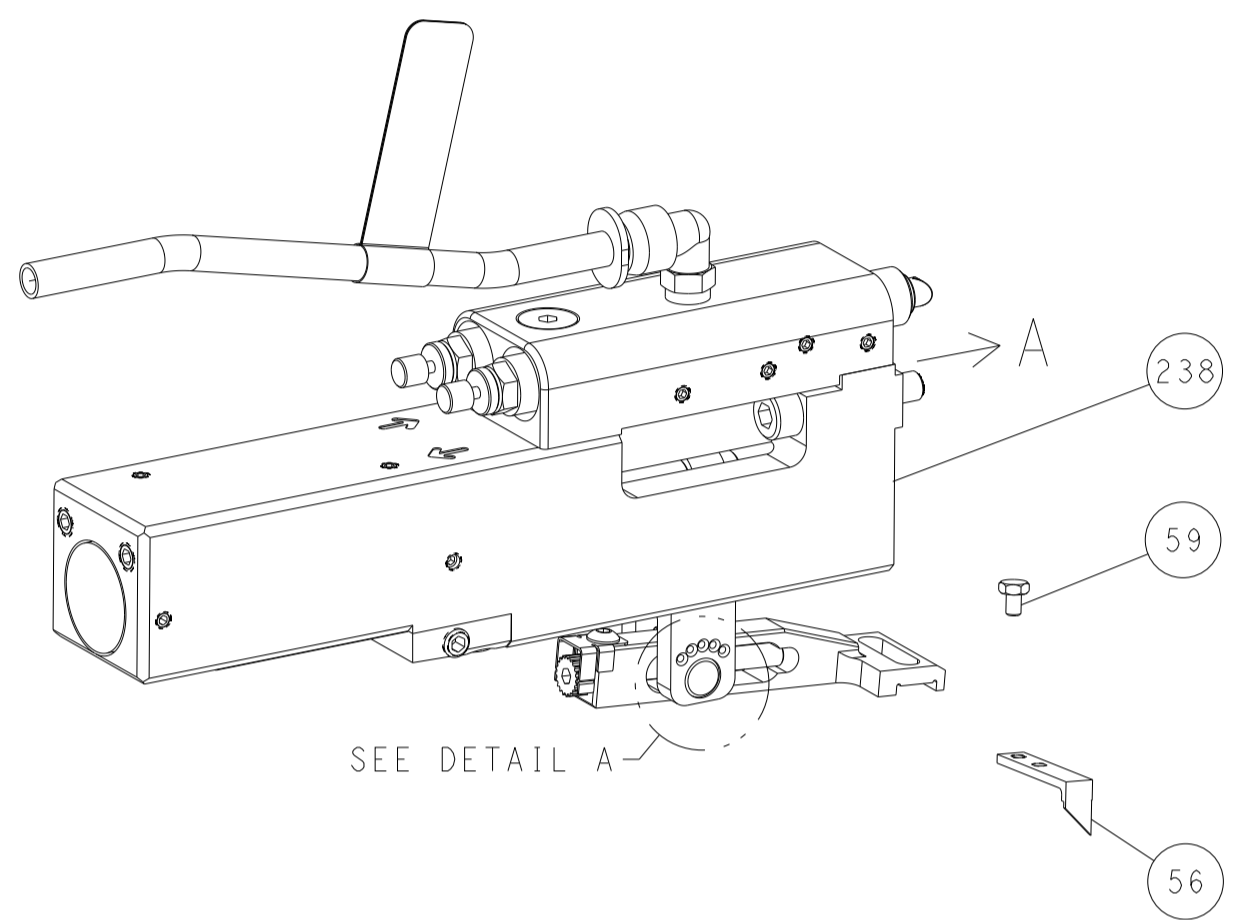

FEED SPRING SETTING POSITION (SHOWN FROM REAR SIDE)



DETAIL A

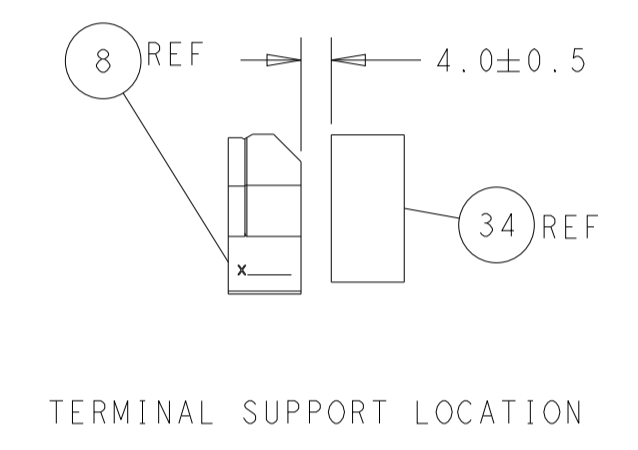
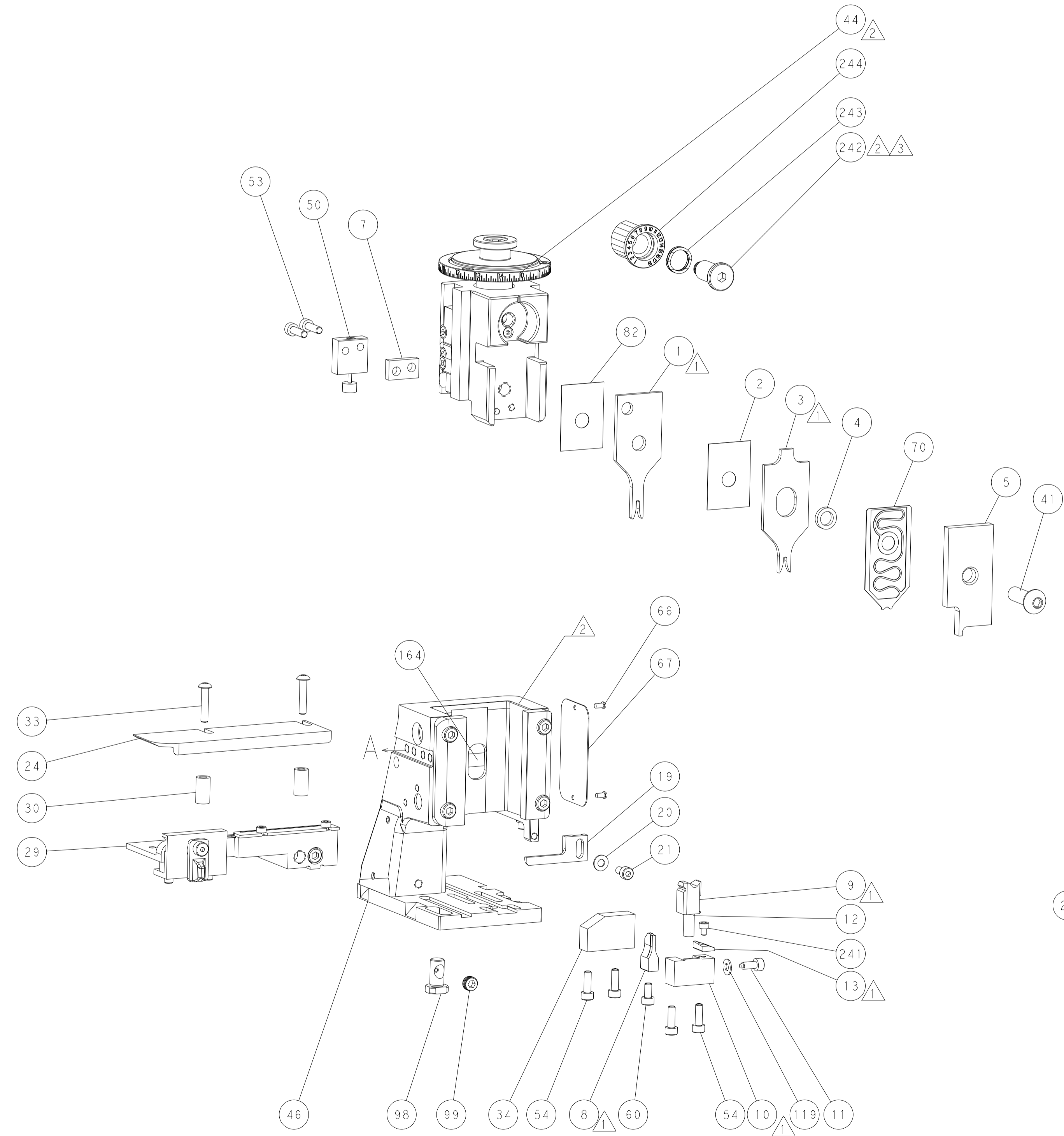

TERMINAL SUPPORT LOCATION

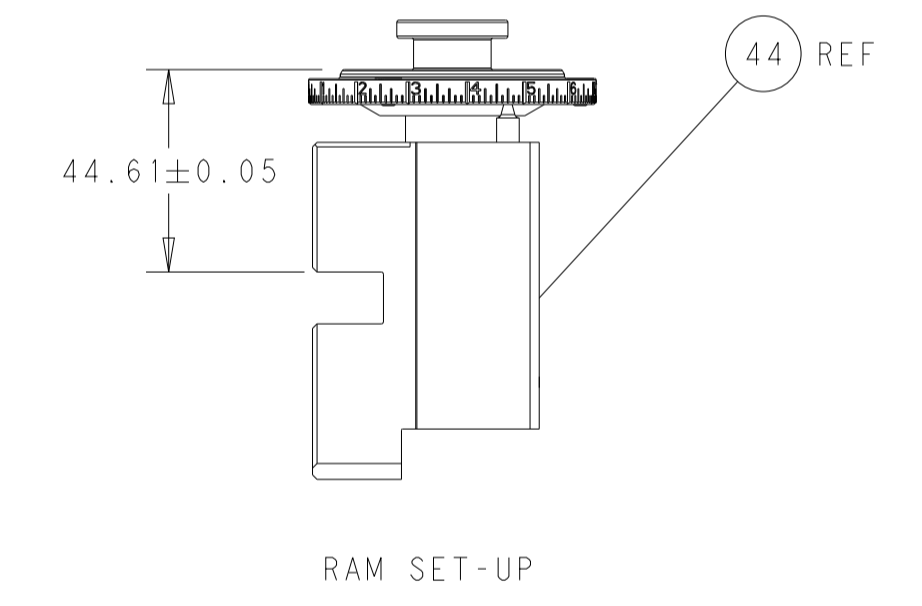

RAM SET-UP

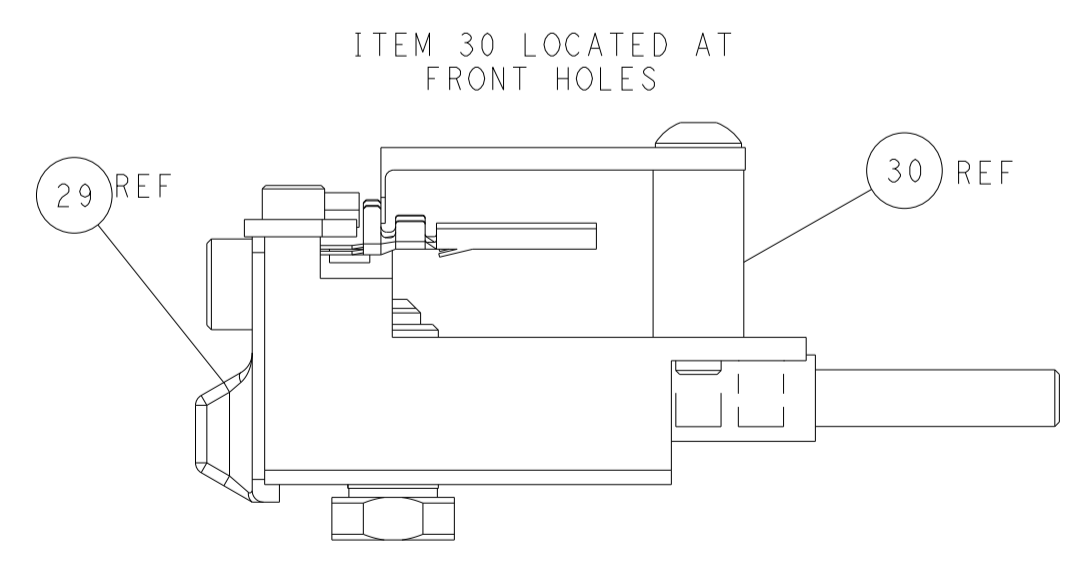

FEED TRACK POSITION GUIDE BY INSULATION BARREL

CAM POSITIONS

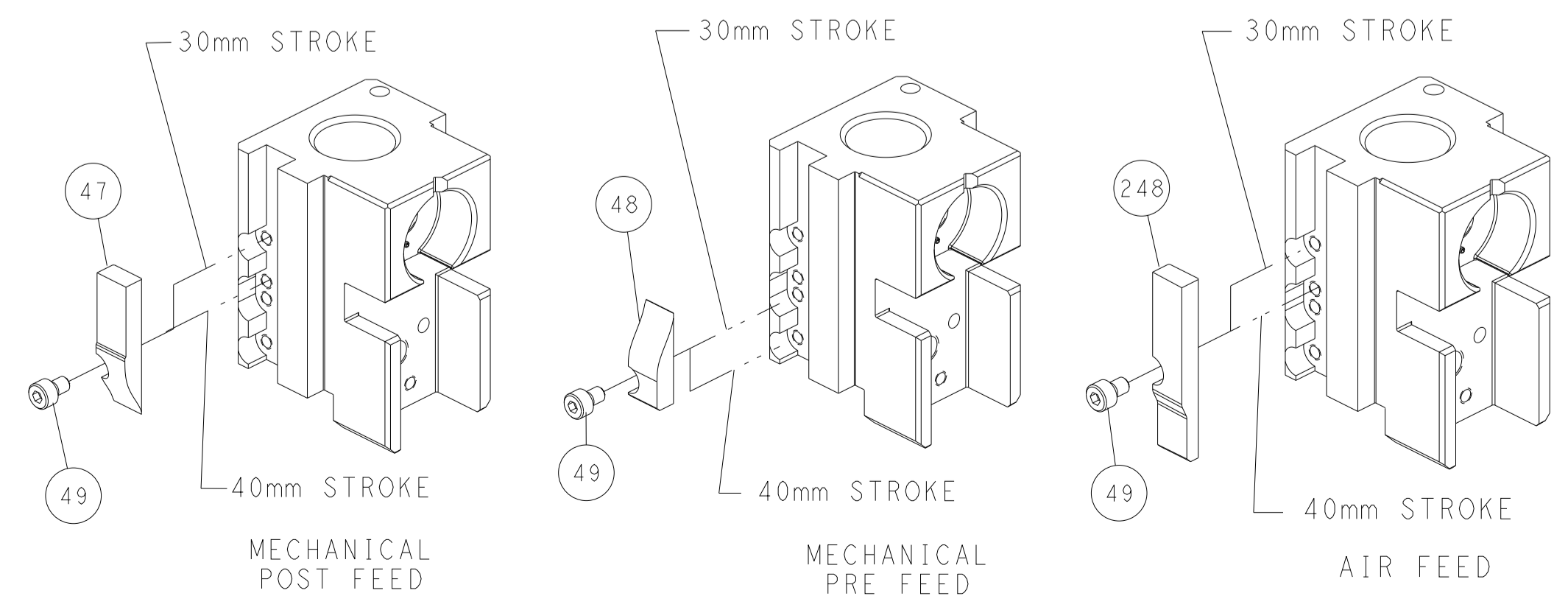

ATLANTIC VERSION
 Shown on sheets 1 of 4 & 2 of 4
 (Pacific version shown on sheets 3 of 4 & 4 of 4)

| | | | |
|--|--|--|--|
| <small>THIS DRAWING IS UNPUBLISHED. RELEASED FOR PUBLICATION. ALL RIGHTS RESERVED. © 2000 BY TYCO ELECTRONICS CORPORATION. THIS DRAWING IS UNPUBLISHED. RELEASED FOR PUBLICATION. ALL RIGHTS RESERVED. © 2000 BY TYCO ELECTRONICS CORPORATION. THIS DRAWING IS UNPUBLISHED. RELEASED FOR PUBLICATION. ALL RIGHTS RESERVED. © 2000 BY TYCO ELECTRONICS CORPORATION.</small> | | DWN: H. HUANG 08OCT2011 CHK: S. XI 08OCT2011 APVD: J. CRUZ 08OCT2011 | NAME: TE Connectivity Harrisburg, PA 17105-3608 |
| DIMENSIONS: mm TOLERANCES UNLESS OTHERWISE SPECIFIED: 0 PLC ± 1 PLC ± 2 PLC ± 3 PLC ± 4 PLC ± ANGLES FINISH ± | PRODUCT SPEC APPLICATION SPEC WEIGHT SCALE: 1:2 | SIZE: A1 CAGE CODE: 00779 DRAWING NO: C=2151125 SHEET 2 OF 4 | RESTRICTED TO: E |

| THIS DRAWING IS UNPUBLISHED. | RELEASED FOR PUBLICATION | | |
|--|--------------------------|--------------------------|------------|
| COPYRIGHT 20 BY TYCO ELECTRONICS CORPORATION. ALL RIGHTS RESERVED. | | | |
| PART NUMBER | REVISION | DESCRIPTION | FEED TYPE |
| 2-2151125-1 | E | FINE CRIMP HEIGHT ADJUST | MECHANICAL |
| 2-2151125-2 | E | FINE CRIMP HEIGHT ADJUST | PNEUMATIC |
| 7-2151125-7 | A | CRIMP TOOLING KIT | - |

PACIFIC VERSION TERMINATOR
INTERFACE ADAPTER



| APPLICATOR DATA | | |
|--------------------------------------|----------------|------|
| CRIMP | SIZE | TYPE |
| WIRE | 1.78 mm [.070] | F |
| INSUL | 2.00 mm [.079] | BX |
| APPLICATOR INSTRUCTIONS 408-35042 | | |

| | | | |
|--|-----------------------------|---|-----------------------------|
| TERMINAL DATA: TE TERMINAL | | TE CRIMP SPECIFICATION | |
| TERMINAL NAME: 070 SERIES TAB CONTACT | | | |
| WIRE STRIP LENGTH 3.50-4.50 mm [1.38-.177 IN] | | INSULATION DIAMETER RANGE Ø1.40-1.90 mm [.055-.075 IN] | |
| TERMINAL APPLICATION SPECIFICATION | (A)114-5092 | - | - |
| | (B)114-5092-3 | - | - |
| TERMINALS APPLIED | | | |
| TE TERMINAL (A) 173633-1 | TE TERMINAL (A) 173633-2 | TE TERMINAL (A) 173633-3 | TE TERMINAL (A) 173633-4 |
| (B) 175188-1 | | | |

| WIRE SIZE | CRIMP HEIGHT mm [INCH] | CRIMP HEIGHT REFERENCE SETTING |
|-----------|-----------------------------|--------------------------------|
| 0.30mm2 | 1.03+/-0.05 [1.041+/-0.002] | 7.9 |
| 0.20mm2 | 0.96+/-0.05 [1.038+/-0.002] | 8.8 |

- RECOMMENDED SPARE PARTS
- REFER TO SUPPLIED INSTRUCTION SHEET FOR CLEANING, LUBRICATION AND STORAGE OF APPLICATOR.
- APPLY PART NUMBER 2-23419-6 LOCTITE TO THREADS OF ITEM 242.
- CRIMP HEIGHT REFERENCE SETTING WAS THE SETTING USED WHEN THE APPLICATOR WAS QUALIFIED AT THE FACTORY. ADJUSTMENT MAY BE NECESSARY WHEN RUNNING APPLICATOR IN THE FIELD.
- UNLESS SPECIFIED OTHERWISE TORQUE VALUES SHALL BE USED PER DOCUMENT, 101-35000.

***WARNING**
ON INSTALLATION, SET WIRE DISC TO CRIMP HEIGHT REFERENCE SETTING FOR LARGEST WIRE SIZE. CRIMP HEIGHT REFERENCE SETTINGS GREATER THAN THE VALUE SHOWN MAY CAUSE DAMAGE TO THE CRIMP TOOLING. REFER TO THE INSTRUCTION SHEET FOR PROPER SETUP AND ADJUSTMENTS.

| LOC | DIST | REVISIONS | | | | | |
|-----|------|-----------|-----|-------------|------|-----|------|
| A | 66 | P | LTN | DESCRIPTION | DATE | DWN | APVD |
| | | - | | SEE SHEET 1 | - | - | - |

| | | | | | |
|---|-----|-----|-------------|-------------------------------------|-----|
| - | 1 | 1 | 2119082-7 | CAM, SNAIL, INSULATION ADJUSTMENT | 244 |
| - | 1 | 1 | 2079764-1 | WASHER, WAVE SPRING, CREST-TO-CREST | 243 |
| - | 1 | 1 | 2119083-1 | RETAINER, INSULATION DIAL | 242 |
| - | 1 | 1 | 7-18023-7 | SCR, SKT HD CAP M3 X 4.0 | 241 |
| - | - | 1 | 2119580-1 | MECHANICAL FEED ASSEMBLY | 239 |
| - | 1 | - | 2844940-1 | AIR FEED MODULE | 238 |
| - | REF | REF | 994970-2 | COUNTER, MAGNETIC | 164 |
| - | 1 | - | 2119641-2 | FEED CAM, AIR FEED | 151 |
| - | 1 | 1 | 2168083-8 | SCR, SKT HD CAP, RoHS, M4 X 16 | 144 |
| - | 4 | 4 | 2168083-9 | SCR, SKT HD CAP, RoHS, M4 X 20 | 143 |
| - | - | 1 | 2119653-2 | FEED CAM, POST FEED | 142 |
| - | 1 | 1 | 1-1803583-0 | APPLICATOR BASIC ASSEMBLY, SF | 141 |
| - | 1 | 1 | 1803516-1 | RAM ASSEMBLY, SF PACIFIC | 140 |
| - | 1 | 1 | 1-18028-2 | WASHER, FLAT, REG M4 | 119 |
| - | 1 | 1 | 2844908-1 | SCREW, LOCKING | 99 |
| - | 1 | 1 | 2844907-1 | POST, LOCKING | 98 |
| - | 1 | 1 | 455888-3 | SPACER, CRIMPER | 82 |
| - | 1 | 1 | 1803607-3 | DOCUMENTATION PACKAGE | 71 |
| - | 1 | 1 | 2119791-9 | DEPRESSOR, WIRE | 70 |
| - | 1 | 1 | 2119740-1 | TAG, IDENTIFICATION | 67 |
| - | 2 | 2 | 2168078-1 | SCREW, DRIVE, RH, RoHS, 2 x .188 | 66 |
| - | 1 | 1 | 5-18022-5 | SCR, HEX HD CAP, M4 X 6.0 | 59 |
| - | 1 | 1 | 1338685-1 | PAWL, FEED | 56 |
| - | 2 | 2 | 2-2168083-5 | SCR, SKT HD CAP, RoHS, M4 X 14 | 53 |
| - | 1 | 1 | 1803382-6 | HOLD DOWN, SPRING LOADED | 50 |
| - | 1 | 2 | 18023-9 | SCR, SKT HD CAP M4 X 6.0 | 49 |
| - | - | 1 | 2119652-1 | FEED CAM, PRE FEED | 48 |
| - | 1 | 1 | 1803602-1 | SCR, BHSC, RoHS (M8 X 25) | 41 |
| - | 1 | 1 | 1752356-1 | SUPPORT, TERMINAL | 34 |
| - | 2 | 2 | 2079383-5 | SCR, BHSC, RoHS (M4 X 20) | 33 |
| - | 2 | 2 | 2-2844962-8 | SPACER, CYLINDRICAL, STRIP GUIDE | 30 |
| - | 1 | 1 | 2844992-1 | ASSEMBLY, STRIP GUIDE | 29 |
| - | 1 | 1 | 1320928-2 | STRIP GUIDE | 24 |
| - | 1 | 1 | 2168083-2 | SCR, SKT HD CAP, RoHS, M4 X 8.0 | 21 |
| - | 1 | 1 | 1-18028-2 | WASHER, FLAT, REG M4 | 20 |
| - | 1 | 1 | 2119533-1 | STRIPPER, SIDE FEED | 19 |
| - | 1 | 1 | 2119806-1 | INSERT, SHEAR | 13 |
| - | 1 | 1 | 3-22280-3 | SPRING, COMPRESSION | 12 |
| - | 1 | 1 | 1-356885-4 | STOP, SHEAR | 11 |
| - | 1 | 1 | 2119805-1 | SHEAR HOLDER, FRONT | 10 |
| - | 1 | 1 | 1803095-3 | FLOATING SHEAR, FRONT | 9 |
| - | 1 | 1 | 1333203-9 | ANVIL, COMBINATION | 8 |
| - | 1 | 1 | 240641-4 | SPACER | 7 |
| - | 1 | 1 | 2119757-8 | DEPRESSOR, SHEAR | 5 |
| - | 1 | 1 | 238011-4 | BLOCK, CRIMPER SPACER | 4 |
| - | 1 | 1 | 1633988-2 | CRIMPER, INSULATION BOX PREMIUM | 3 |
| - | 1 | 1 | 455888-3 | SPACER, CRIMPER | 2 |
| - | 1 | 1 | 3-456404-5 | CRIMPER, WIRE PREMIUM | 1 |

| | | | | | | | | | | | |
|-------------|---------|--|---------|-------------------------|---------|----------------------|--------|-------------------------|--|----------------------------------|------------------|
| DIMENSIONS: | | TOLERANCES UNLESS OTHERWISE SPECIFIED: | | DWG: H. HUANG 08OCT2011 | | CHK: S. XI 08OCT2011 | | APVD: J. CRUZ 08OCT2011 | | NAME: Ocean Side Feed Applicator | |
| mm | 0 PLC ± | 1 PLC ± | 2 PLC ± | 3 PLC ± | 4 PLC ± | ANGLES ± | FINISH | SIZE: A1 | CAGE CODE: 00779 | DRAWING NO: ©=2151125 | RESTRICTED TO: - |
| MATERIAL: - | | | | | | | | WEIGHT: - | Customer Accessible Production Drawing | | SCALE: 1:2 |
| | | | | | | | | SHEET: 3 | OF: 4 | REV: E | |

PACIFIC VERSION
Shown on sheets 3 of 4 & 4 of 4
(Atlantic version shown on sheets 1 of 4 & 2 of 4)

| LOC | DIST | REVISIONS | | | | | |
|-----|------|-----------|-----|-------------|------|-----|------|
| A | 66 | P | LTN | DESCRIPTION | DATE | DWN | APVD |
| | | - | | SEE SHEET 1 | - | - | - |

FEED TYPE MECHANICAL

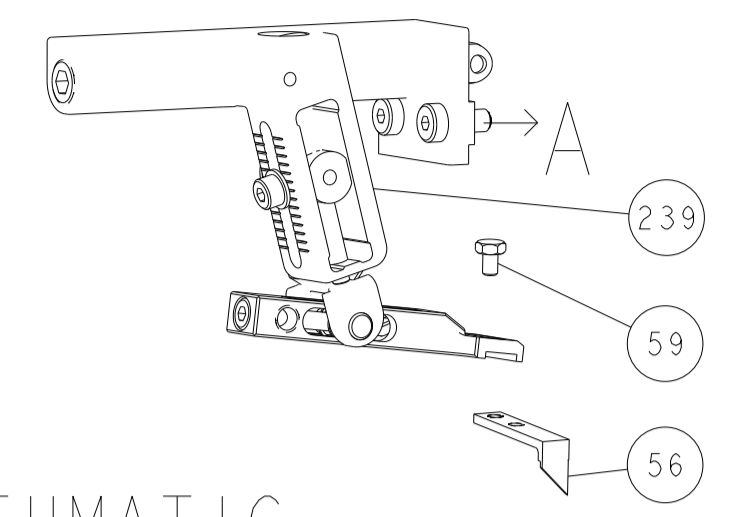

PNEUMATIC

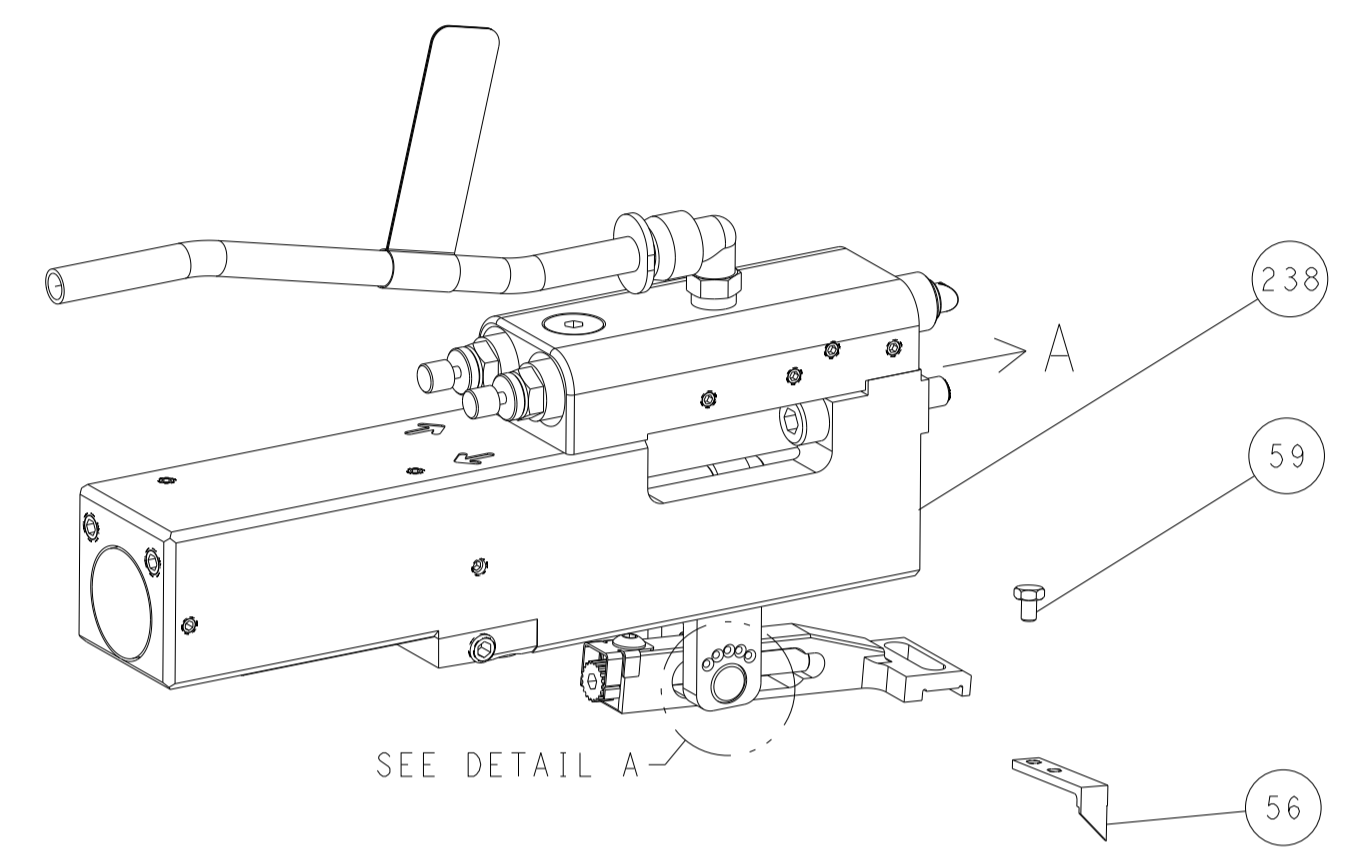

FEED SPRING SETTING POSITION (SHOWN FROM REAR SIDE)

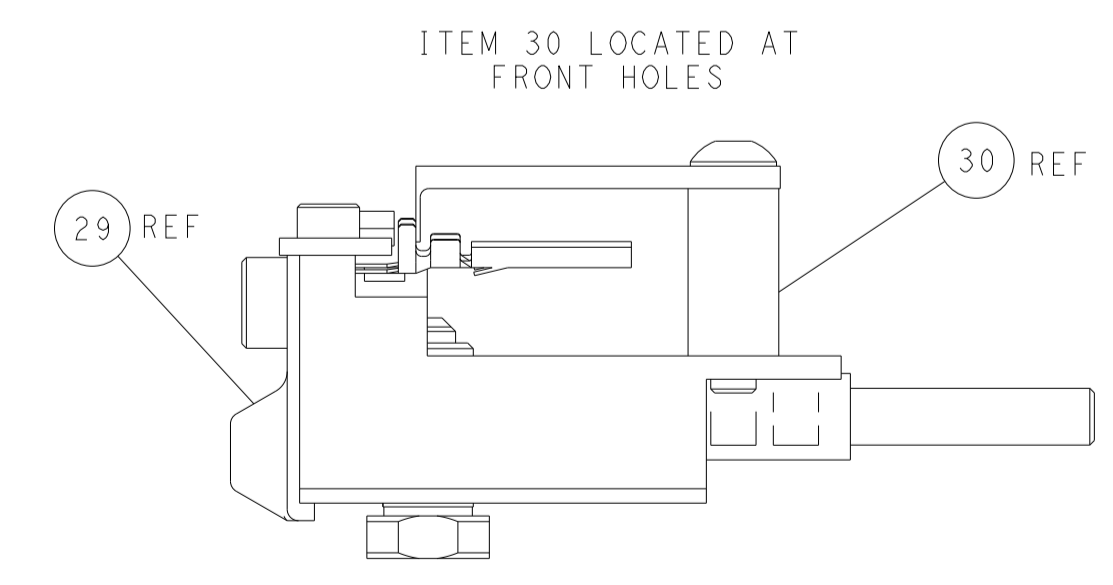
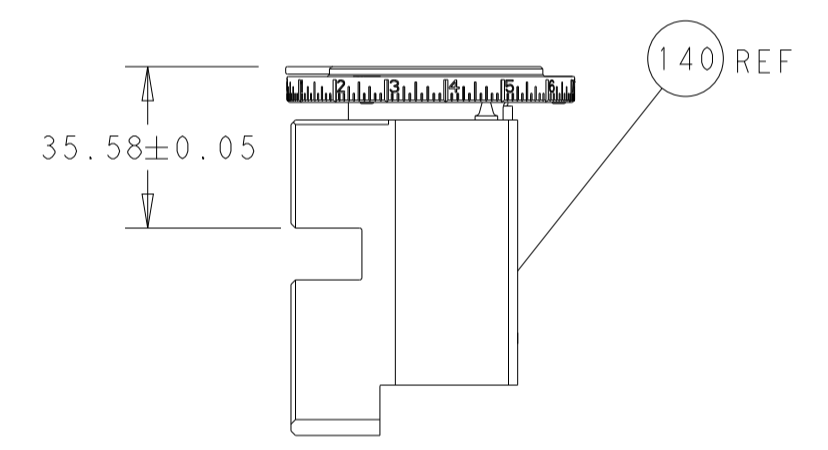
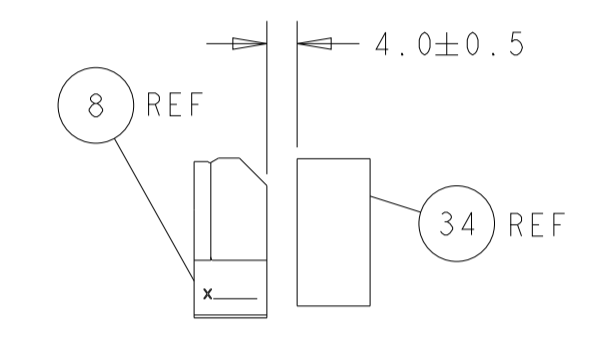
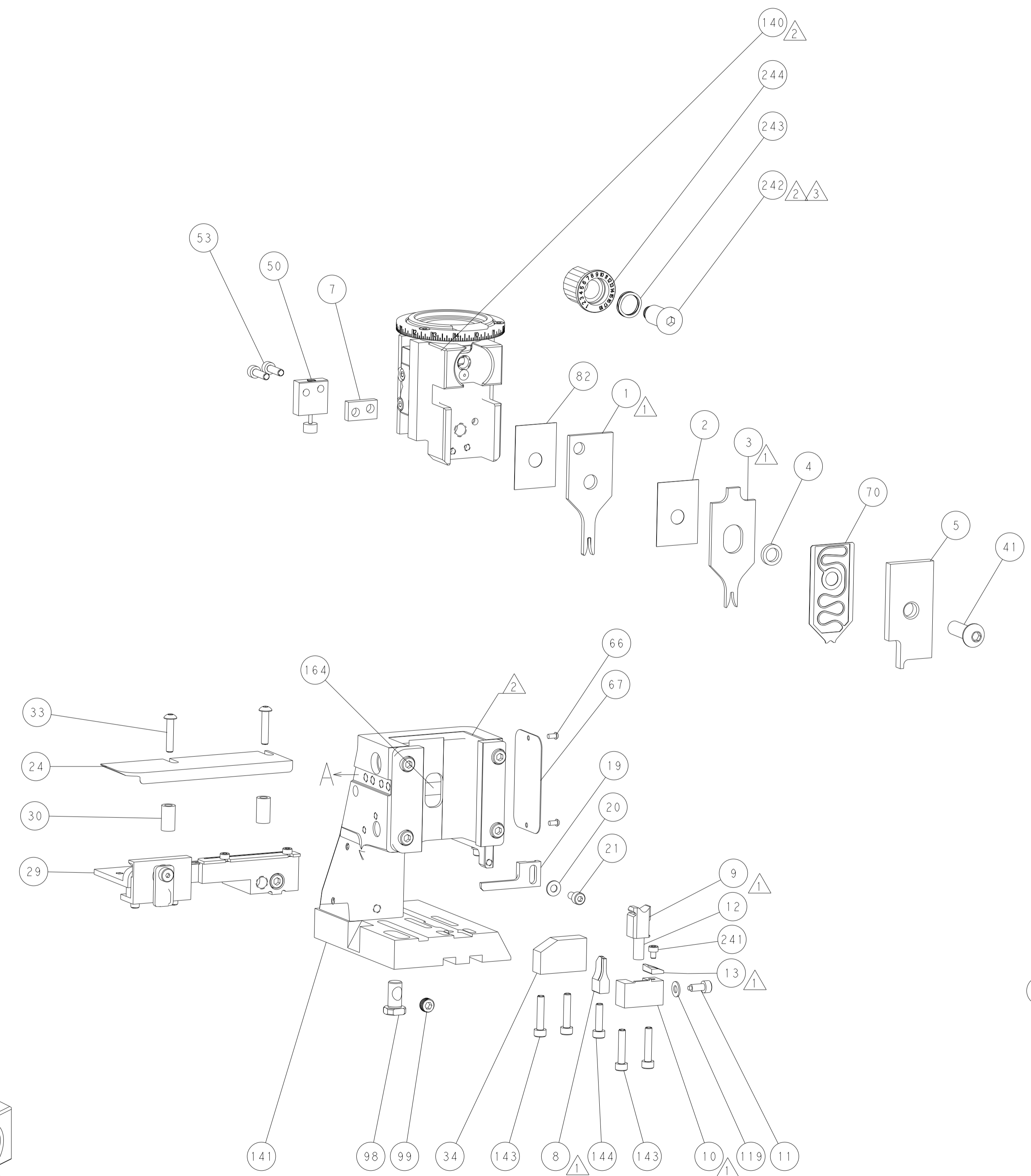
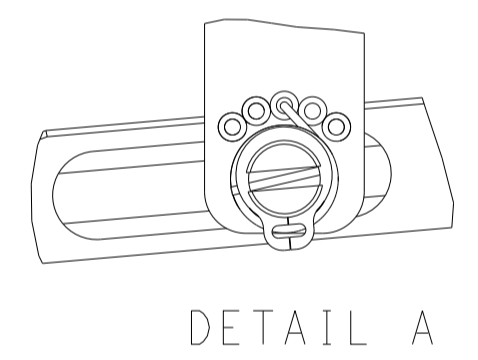

CAM POSITIONS

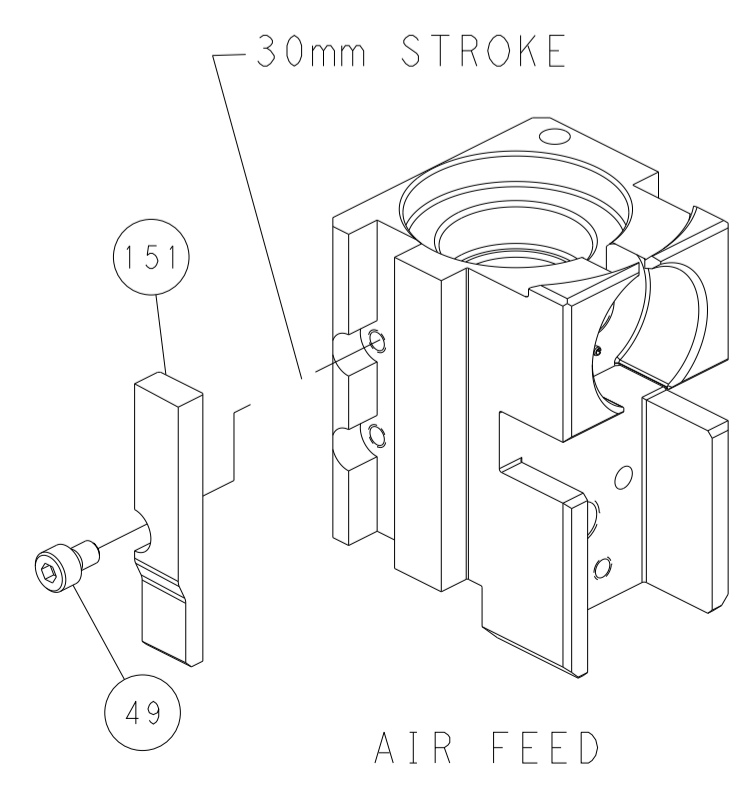
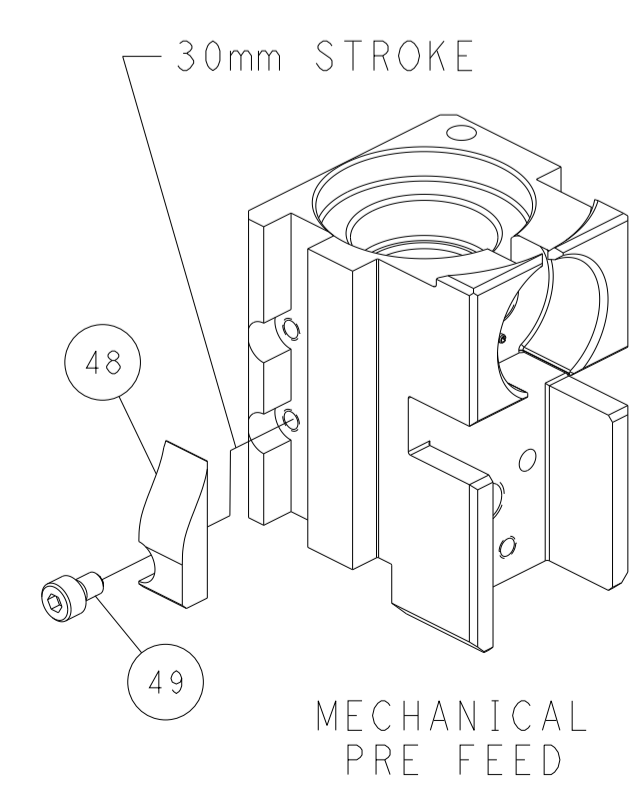
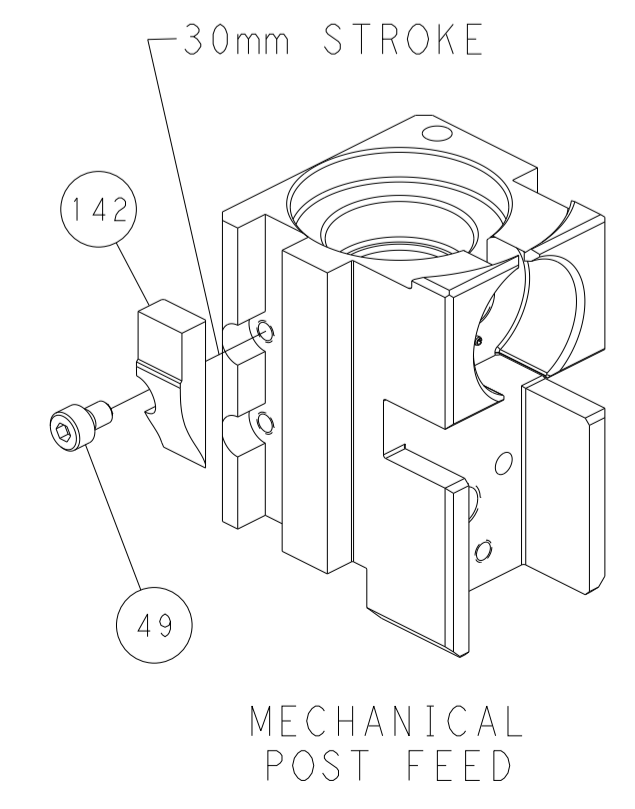

PACIFIC VERSION
 Shown on sheets 3 of 4 & 4 of 4
 (Atlantic version shown on sheets 1 of 4 & 2 of 4)

| | | | |
|--|--|--|---|
| <small>THIS DRAWING IS A CONTROLLED DOCUMENT FOR TYCO ELECTRONICS CORPORATION. IT IS THE PROPERTY OF TYCO ELECTRONICS CORPORATION AND IS NOT TO BE REPRODUCED OR TRANSMITTED IN ANY FORM OR BY ANY MEANS, ELECTRONIC OR MECHANICAL, INCLUDING PHOTOCOPYING, RECORDING, OR BY ANY INFORMATION STORAGE AND RETRIEVAL SYSTEM, WITHOUT THE WRITTEN PERMISSION OF TYCO ELECTRONICS CORPORATION.</small> | | DWN: H. HUANG 08OCT2011 CHK: S. XI 08OCT2011 APVD: J. CRUZ 08OCT2011 | TE Connectivity Harrisburg, PA 17105-3608 |
| DIMENSIONS: mm TOLERANCES UNLESS OTHERWISE SPECIFIED: 0 PLC ± 1 PLC ± 2 PLC ± 3 PLC ± 4 PLC ± ANGLES FINISH ± | | NAME: Ocean Side Feed Applier APPLICATION SPEC: | SIZE: A1 CAGE CODE: 00779 DRAWING NO: C=2151125 RESTRICTED TO: |
| MATERIAL: | | WEIGHT: | SCALE: 1:2 SHEET: 4 OF 4 REV: E |