

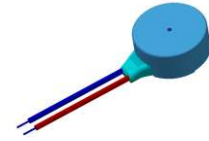

PUIaudio



Data Sheet

HD-LA0803-LW10-R

PUI Audio's 8mm diameter by 3mm high **HD-LA0803-LW10-R** is a coin-style linear resonant actuator haptic device that employs a spring and mass system for fast response times and strong vibration in a small package.

Features:

- Designed to be driven with a 235 Hz sinewave
- Convenient lead wires and double-sided tape for easy implementation
- Generates 1.5Gs with no more than 45 dBA acoustic noise

Specifications

Parameters	Values	Units
Input Voltage (AC Sinewave)	2	Vrms
Operational Frequency	235	Hz
Coil Resistance	25 ±15%	Ohms
Vibration	1.5 ±0.3	Gs RMS
Max Current Draw (at 2 VRMS)	90	mA
Rise Time (50% of steady state)	50	mS
Fall Time (50% of steady state)	80	mS
Magnet Material	NdFeB	-
Acoustic Noise (Max)	45	dBA
Housing Material	SPC	-
Acceptable Soldering Methods	Hand Solder	-
Environmental Compliances	RoHS/REACH	-
Weight	1	Grams
Storage Temperature	-40 ~ +80	°C
Operating Temperature	-20 ~ +70	°C

Measurement Methods

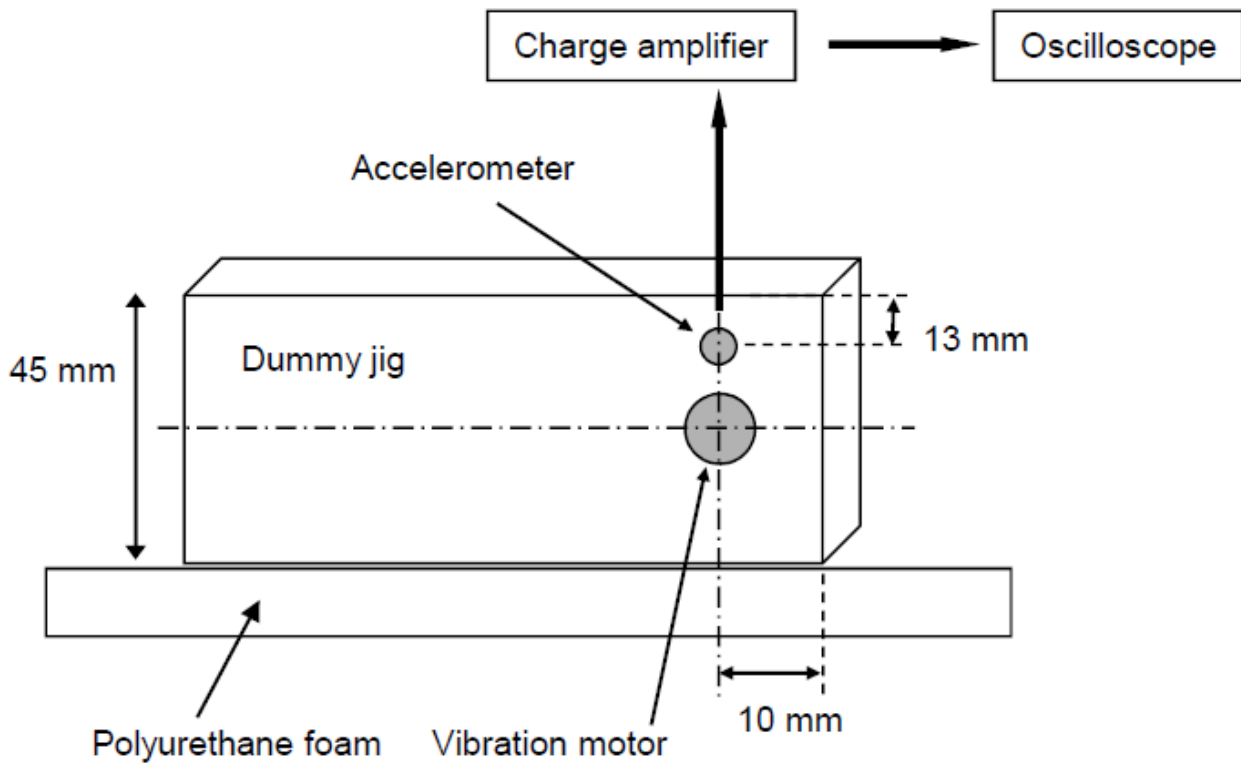

■ Specification of the dummy Jig

- Size : 45mm x 105mm x 15mm
- Weight : 100gr
- Material : Bakelite
- Vibration motor should be attached by using a double-sided tape.

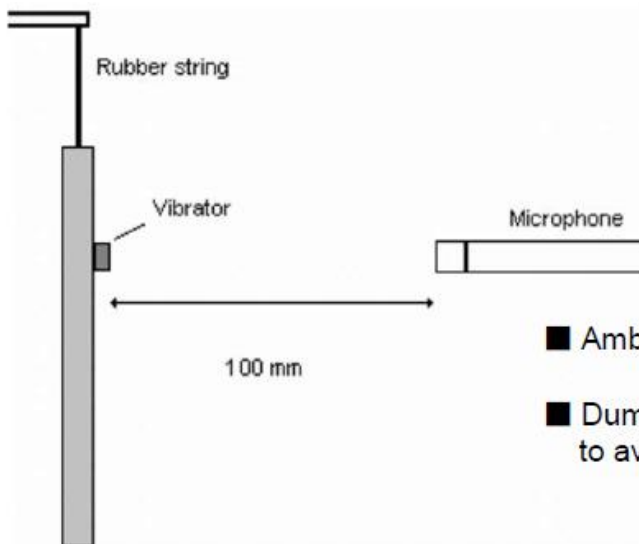

■ Ambient noise level : 23dB(A)

■ Dummy jig must be suspended by a rubber string to avoid disturbance.

Typical Frequency Response Characteristics

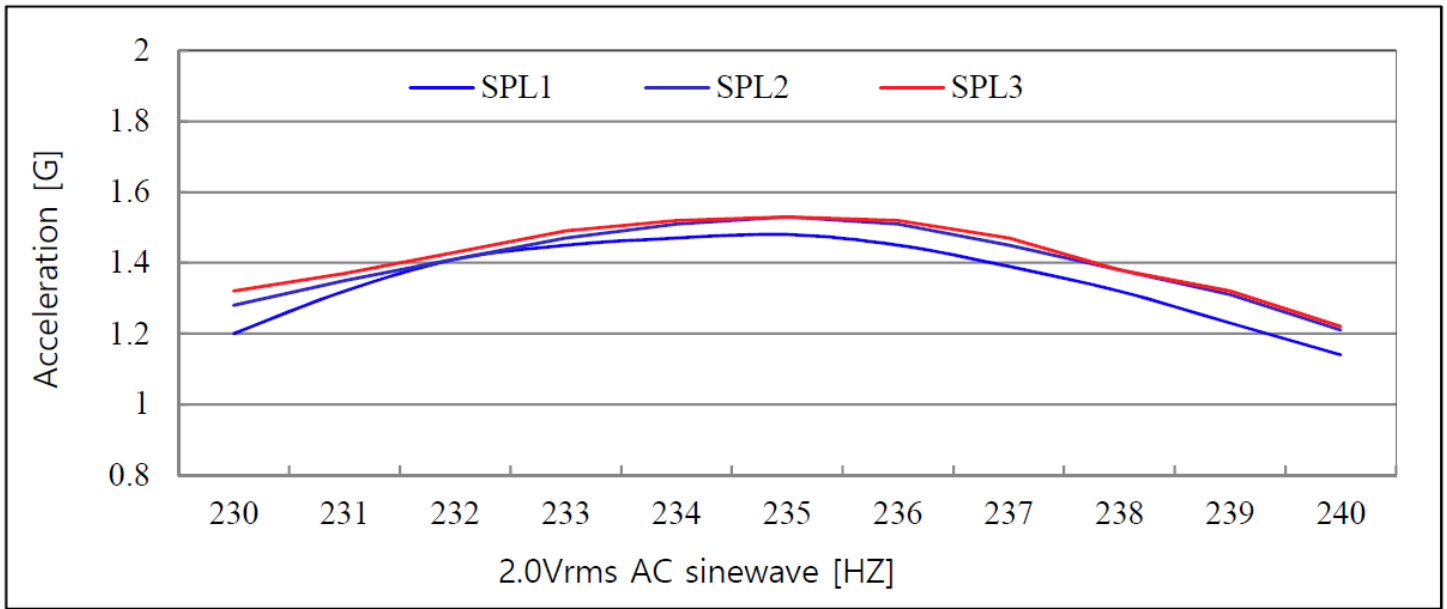

Reliability Testing

Type of Test	Test Specifications
High Temperature Test	96 hours at 80°C
Low Temperature Test	96 hours at -40°C
H2S Corrosion Resistance Test	Concentration: 3 ±1 PPM Test Environment: 40°C, humidity 80% RH Test Duration Time: 240 hours
Temperature Cycle Testing	Temperature: -40°C to +80°C Test Duration: 30 minutes Test Cycles: 15 cycles
Vibration Test	3mm deflection at 1000 cycles per minute, for 10 minutes in each axis (X, Y, Z).
Drop Test	Weight: Set the linear vibration motor to the around 100g (include the linear vibration motor) weight of block. Drop Height: 150cm Floor Material: Steel Direction: ±X, ±Y, ±Z; total 6 faces Number of Times: Each face 3 Times
Load Test	100,000 operating cycles in room temperature Cycle test condition: 2 seconds on, 1 second off

Acceleration, resistance, rated current and noise must meet specifications after allowing the device to rest for 4 hours after test.

Dimensions (Red wire is positive)

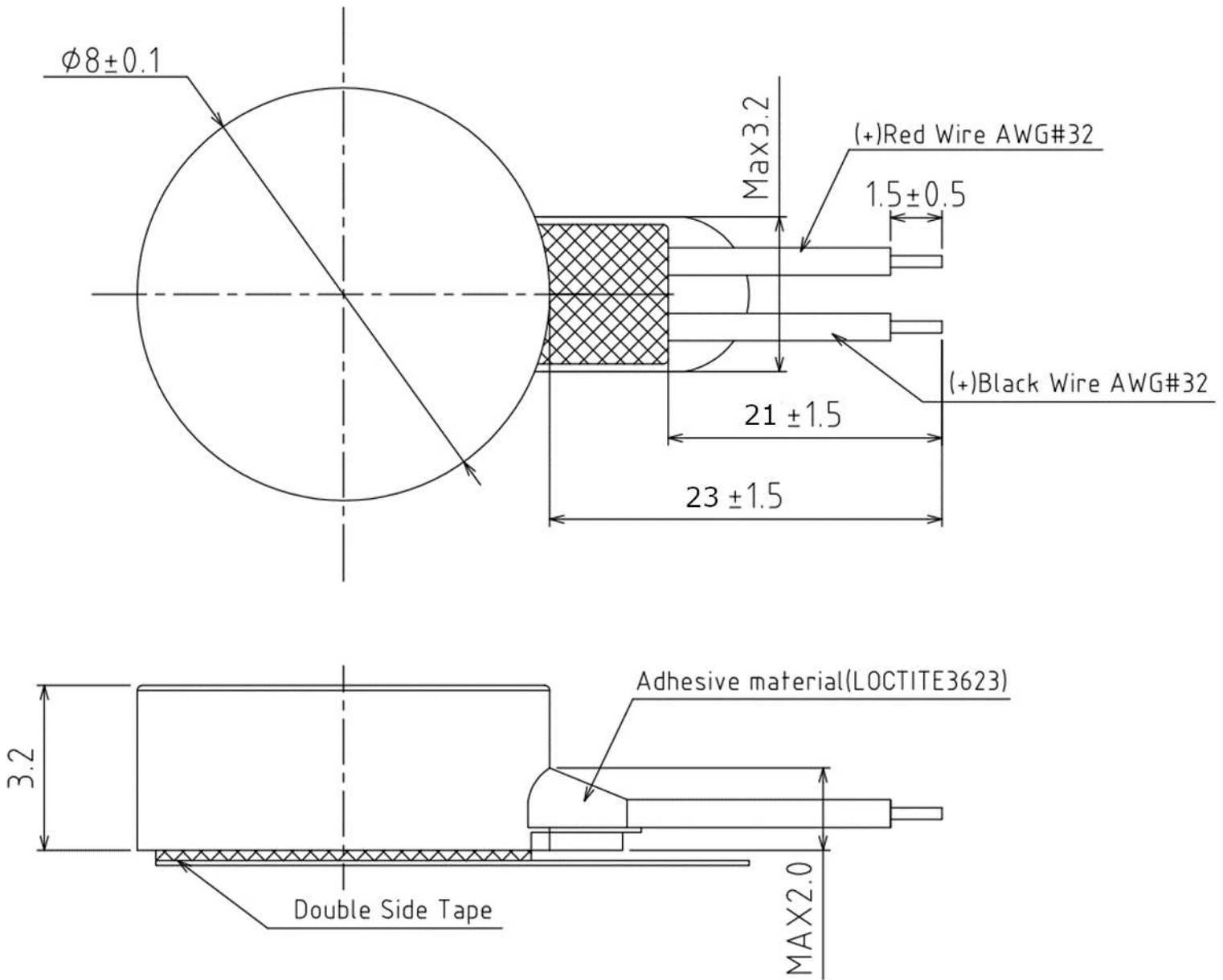

Specifications Revisions

Revision	Description	Date
A	Released from Engineering	4/6/2021
B	Updated Lead Wire Length	7/12/2022

Note:

1. Unless otherwise specified:
 - A. All dimensions are in millimeters.
 - B. Default tolerances are $\pm 0.5\text{mm}$ and angles are $\pm 3^\circ$.
2. Specifications subject to change or withdrawal without notice.