



SANYO Semiconductors

DATA SHEET



LV25700PM

Bi-CMOS IC

For Car Radio

Single chip Tuner IC

Overview

The LV25700PM is a tuner IC for car radio, which incorporates an AM/FM Tuner, PLL, AM/FM Noise Canceller (NC), FM Stereo-decoder (MPX), Multipath-noise Rejection Circuit (MRC), and RDS Demodulator Logic-controller. The basic performance is based on the LV25210, and both adjustment-free operation and software control of the IF band variable filter are possible.

This IC enables easy configuration of a low-cost, high performance analog tuner for OEM.

Functions

- AM/FM + FE + PLL + IF + NC + MPX + MRC + RDS Demodulator + Logic-controller

Features

- World-wide compatible tuners

World-wide compatible tuners can be configured and supplied with a single tuner IC.

FM is compatible with U.S., European, Japanese and Weather bands, while AM is compatible with LW, MW and SW.

High performance image cancel mixer incorporated in FM MIX.

PLL fast locking, RDS demodulator and AM/FM noise canceller incorporated

- Self-contained type IF band variable filter incorporated

Detects any neighboring interfering FM stations and the modulation index, and enables various bandwidth settings of the IF bandpass filter by using the software incorporated in the IC.

Continued on next page.

- CCB is a registered trademark of SANYO Electric Co., Ltd.
- CCB is SANYO Semiconductor's original bus format. All bus addresses are managed by SANYO Semiconductor for this format.

■ Any and all SANYO Semiconductor Co.,Ltd. products described or contained herein are, with regard to "standard application", intended for the use as general electronics equipment (home appliances, AV equipment, communication device, office equipment, industrial equipment etc.). The products mentioned herein shall not be intended for use for any "special application" (medical equipment whose purpose is to sustain life, aerospace instrument, nuclear control device, burning appliances, transportation machine, traffic signal system, safety equipment etc.) that shall require extremely high level of reliability and can directly threaten human lives in case of failure or malfunction of the product or may cause harm to human bodies, nor shall they grant any guarantee thereof. If you should intend to use our products for applications outside the standard applications of our customer who is considering such use and/or outside the scope of our intended standard applications, please consult with us prior to the intended use. If there is no consultation or inquiry before the intended use, our customer shall be solely responsible for the use.

■ Specifications of any and all SANYO Semiconductor Co.,Ltd. products described or contained herein stipulate the performance, characteristics, and functions of the described products in the independent state, and are not guarantees of the performance, characteristics, and functions of the described products as mounted in the customer's products or equipment. To verify symptoms and states that cannot be evaluated in an independent device, the customer should always evaluate and test devices mounted in the customer's products or equipment.

SANYO Semiconductor Co., Ltd.

<http://semicon.sanyo.com/en/network>

LV25700PM

Continued from preceding page.

- Auto alignment EEPROM not necessary. It is incorporated inside the IC
FM RF, VCO, Null-voltage, Mute-on, Mute-ATT, SNC, HCC, Separation, S-meter, AM/FM AGC sensitivity, AM/FM IF gain, SD sensitivity, I²C bus compatible
* This IC can be supplied in the adjusted state. Some adjustments are necessary depending on the specifications and external components.
- Other functions
Neighboring interference (Quality Out) RDS AF-search support
I²C communication bus

Specifications

Absolute Maximum Ratings at Ta = 25°C, GND = 0V

Parameter	Symbol	Conditions	Ratings	Unit
Maximum supply voltage	V _{CC_H} max		8.7	V
	V _{CC_L} max		5.7	V
	V _{DD} max		6.5	V
	V _{DDBUS} max		6.5	V
Maximum input current	V _{IN} max		6.5	V
Maximum output current	V _O max		6.5	V
Allowable power dissipation	Pd max	(Ta ≤ 85°C)	1040	mW
Operating temperature	Topr		-40 to +85	°C
Storage temperature	Tstg		-40 to +150	°C

Recommended Operating Conditions at Ta = 25°C, GND = 0V

Parameter	Symbol	Conditions	Ratings	Unit
Recommended supply voltage	V _{CC_H}	PIN 1, 2, 15, 68, 80	8.0	V
	V _{CC_L}	PIN 53, 74	5.0	V
	V _{DD}	PIN 35	5.0	V
	V _{DDBUS}	PIN 34	5.0	V

Recommended Operating Conditions at Ta = 25°C, GND = 0V

Parameter	Symbol	Conditions	Ratings			Unit
			min	typ	max	
Operating supply voltage range	V _{DD}	PIN 35	4.5	5.0	5.5	V
	V _{DDBUS}	PIN 34 (*1)	3.0	5.0	5.5	V
	V _{COP_H}	PIN 1, 2, 15, 68, 80	7.5	8.0	8.5	V
	V _{COP_L}	PIN 53, 74	4.5	5.0	5.5	V
Logic operation, memory hold voltage range	V _{DDLOGIC}	PIN 35	3.5		5.5	V
Internal supply	V _{REG}	PIN 36 V _{DDLOGIC} > 3.5V (*2)		3.0		V
Input High level voltage	V _{IH}	PIN 31, 32, 33	0.8V _{DDBUS}		V _{DDBUS}	V
Input Low level voltage	V _{IL}	PIN 31, 32, 33	0		0.2V _{DDBUS}	V
Input amplitude voltage	V _{IN}	PIN 39	0.5		1.5	Vrms
Input frequencies	F _{IN}	PIN 39		20.5		MHz
Input High level current	I _{IH} (1)	PIN 39, V _I = V _{DD} = 5.0V	2.0	5.0	15.0	μA
	I _{IH} (2)	PIN 31, 32, 33 V _I = V _{DD} = V _{DDBUS} = 5.0V			3.0	μA
Input Low level voltage	I _{IL} (1)	PIN 39, V _I = V _{DD} = V _{SS}	2.0	5.0	15.0	μA
	I _{IL} (2)	V _I = V _{SS}			3.0	μA
Hysteresis width	V _H	PIN 31, 32, 33	0.1V _{DDBUS}	0.2V _{DDBUS}		V
Output High level voltage	V _{OH} (1)	PIN 26, 27, 28, 29, 30 I _O = -1mA, V _{DD} = V _{DDBUS}	V _{DD} -1.0			V
	V _{OH} (2)	PIN 38 I _O = -200μA, V _{DD} = V _{DDBUS}	V _{REG} -1.0			V
	V _{OH} (3)	PIN 21, 22 I _O = -500μA, V _{DD} = V _{DDBUS}	V _{DD} -1.0			V

Continued on next page.

LV25700PM

Continued from preceding page.

Parameter	Symbol	Conditions	Ratings			Unit
			min	typ	max	
Output Low level voltage	V _{OL} (1)	PIN 26, 27, 28, 29, 30 I _O = -1mA, V _{DD} = V _{DDBUS}			1.0	V
	V _{OL} (2)	PIN 38 I _O = -200μA, V _{DD} = V _{DDBUS}			1.0	V
	V _{OL} (3)	PIN 21, 22 I _O = -500μA, V _{DD} = V _{DDBUS}			1.0	V
	V _{OL} (4)	PIN 31, 32 I _O = -5mA, V _{DD} = V _{DDBUS}			1.0	V
Output off leak current	I _{off} (1)	PIN 26, 27, 28, 29, 30, 31, 32	-3		+3	μA
	I _{off} (2)	PIN 21, 22	-100		+100	nA
RESET application time at power on.	t _{POR}	PIN 33	50			ms
RESET application time at instantaneous power failure.	t _{PDR}	PIN 33	50			ms
Oscillation stabilization time after RESET input is completed	t _{CKR}	PIN 36 (*2)	80			ms

(*1): Use with V_{DD} < V_{DDBUS} is prohibited.

(*2): External access to LV25700, other than RESET or power supply, that results in V_{REG} = V_{DDLOGIC} during RESET application and until XIN oscillation stabilizes (t_{CKR}), should wait until the t_{CKR} time elapses after RESET is released.

Package Dimensions

unit : mm (typ)

3174A

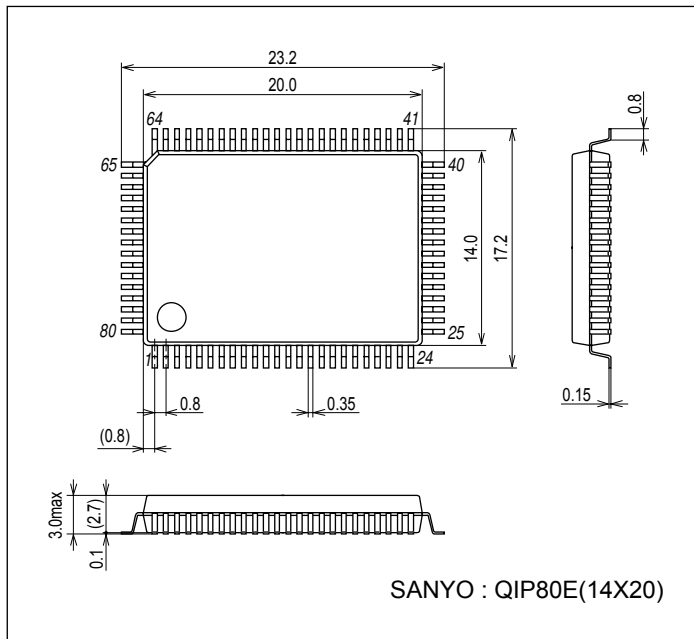

LV25700PM

Reset Timing at Power-ON

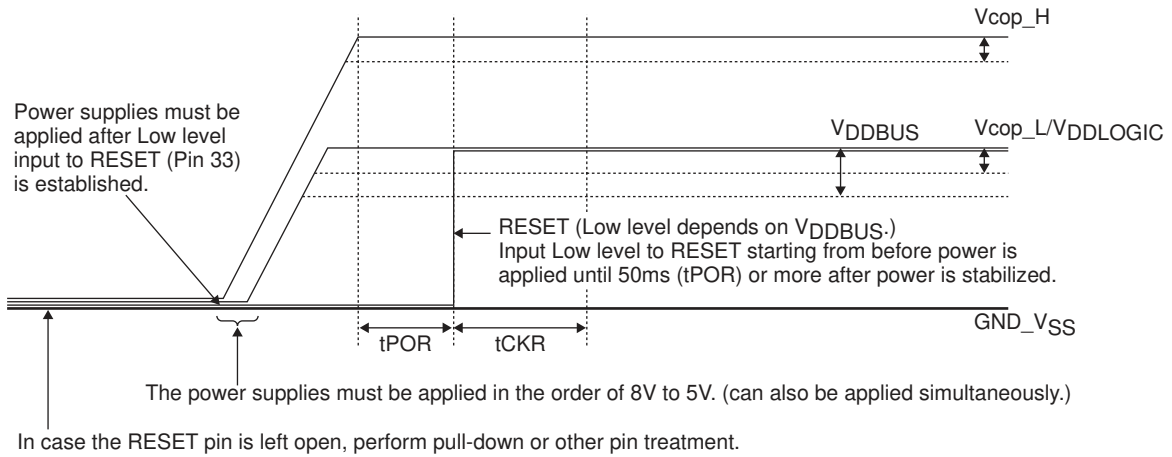

Reset Timing at Instantaneous Power Failure

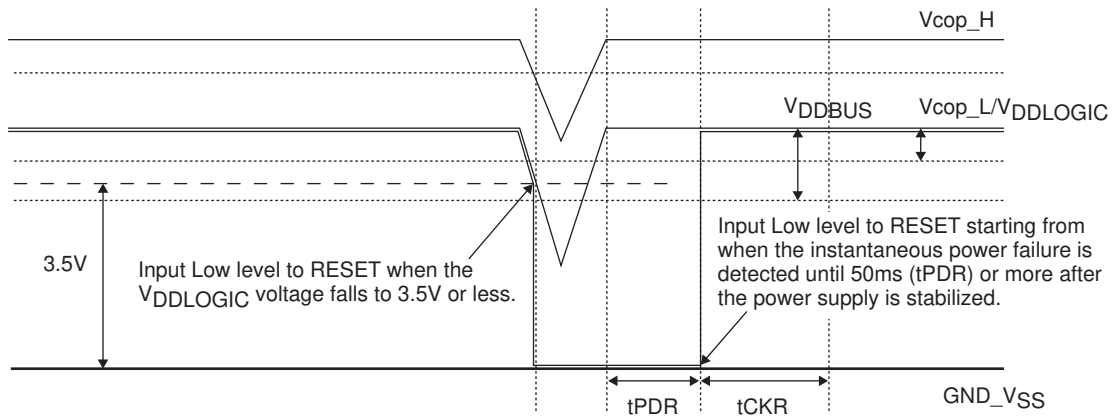

Reset Timing at Power-OFF

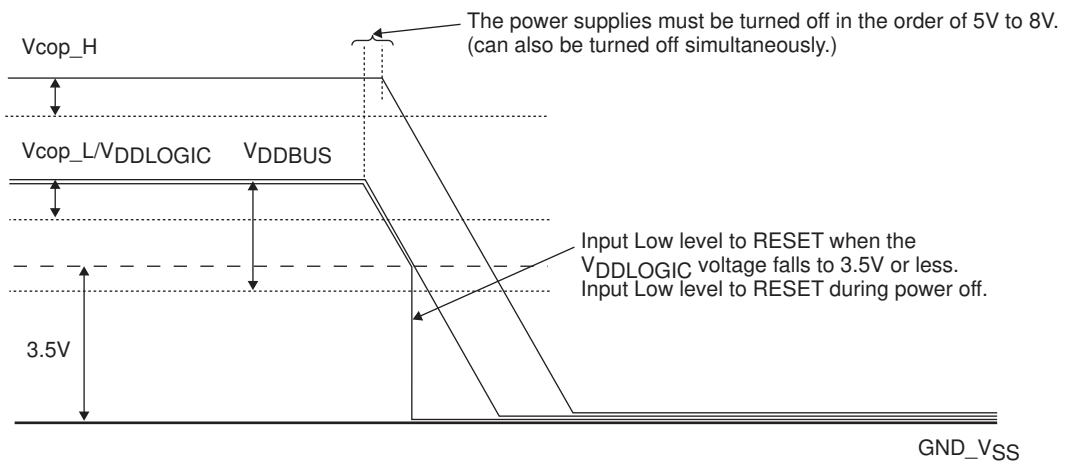

LV25700PM

AC Characteristics

Operating Characteristics at $T_a = 25^\circ\text{C}$, $V_{CC} = 8.0\text{V}$, $V_{DD} = 5.0\text{V}$, unless otherwise specified. Ratings for publications

* : These measurements are made using the Yamaichi Electronics IC51-0804-819-2 IC socket. An IHF bandpass filter is used as the audio filter.

[FM Characteristics] FM Front End Mixer Input

Parameter	Symbol	Conditions	min	typ	max	Unit
Current drain-8V	$I_{CCOF-8V}$	No input, FM mode I1+I2+I15+I68+I80	60	73	85	mA
Current drain-5V	$I_{CCOF-5V}$	No input, FM mode I35+I53+I74	37	45	52	mA
Demodulation output	V_{O-FM_1}	98.1MHz, 60dB μ V, 1kHz, 100%mod, pin 49	400	550	700	mVrms
Detection output	V_{O-FM_2}	98.1MHz, 60dB μ V, 1kHz, 100%mod, pin 60	280	380	480	mVrms
Channel balance	CB	98.1MHz, 60dB μ V, 1kHz, pins 49 and 50	-1	0	1	dB
Total harmonic distortion	THD-Fm mono (1)	98.1MHz, 60dB μ V, 1kHz, 100%mod, pin 49		0.2	1	%
Total harmonic distortion	THD-Fm mono (2)	98.1MHz, 60dB μ V, 1kHz, 150%mod, pin 49		0.3	2.5	%
Signal to noise ratio (MONO)	S/N-FM-MONO	98.1MHz, 60dB μ V, 1kHz, 100%mod, pin 49	60	70		dB
Signal to noise ratio (ST)	S/N-FM-ST	98.1MHz, 60dB μ V, 1kHz, 100%mod, pin 49, L+R = 90%, pilot = 10%	58	65		dB
AM suppression ratio	AMR	98.1MHz, 60dB μ V, 1kHz, 100%mod, 30% in AM mode, fm = 400Hz, pin 49	58	67		dB
Muting attenuation (1)	Att-1	98.1MHz, 60dB μ V, 1kHz, with V64 = 0→2V, pin 49 attenuation (Mute ATT SW = 0)	-30	-25	-20	dB
Muting attenuation (2)	Att-2	98.1MHz, 60dB μ V, 1kHz, with V64 = 0→2V, pin 49 attenuation (Mute ATT SW = 2)	-23	-18	-13	dB
Muting attenuation (3)	Att-3	98.1MHz, 60dB μ V, 1kHz, with V64 = 0→1V, pin 49 attenuation (Mute ATT SW = 2)	-11	-6	-1	dB
Separation	Separation	98.1MHz, 60dB μ V, mod = 100%, pilot = 10%, pin 49 output ratio Separation control adj	27	43		dB
Stereo ON level	ST-ON	Pilot demodulation at which V27 < 0.5V is established	1.5	3.8	5.5	%
Stereo OFF level	ST-OFF	Pilot demodulation at which V27 < 3.0V is established	1.2	3.2		%
Main distortion factor	THD-Main L	98.1MHz, 60dB μ V, L+R = 90%, pilot = 10%, pin 49		0.5	1.2	%
SNC output attenuation	AttSNC	98.1MHz, 40dB μ V, L-R = 90%, pilot = 10%, pin 49 (L→R)	5	10	15	dB
HCC output attenuation	FM HCC	98.1MHz, 60dB μ V, 10kHz, modulation = 30% reference, input level at which the output is down by -3dB	24	30	36	dB μ V
Input limiting voltage	Vi-lim	98.1MHz, 60dB μ V, 30%mod, MIX input at which the input reference output is down by -3dB, V42 = 0V, V29 = 0V, with MUTE = OFF	-6	-1	4	dB μ V
Muting sensitivity	Vi-mute	MIX input level at V64 = 0.7V, non-mod	0.1	5	9.9	dB μ V
SD sensitivity	SD-senFM	MIX input level at which SD pin is ON, shifter- adj, non-mod	20	25	30	dB μ V
IF count sensitivity	IF-count-sens. FM	IF count sensitivity at MIX input, non-mod			20	dB μ V

Continued on next page.

LV25700PM

Continued from preceding page.

Parameter	Symbol	Conditions	min	typ	max	Unit
S-meter DC output	VSMFM-1	No input, pin 44 DC output non-mod			0.5	V
	VSMFM-2	10dB μ V, pin 44 DC output non-mod		0.85		V
	VSMFM-3	30dB μ V, pin 44 DC output non-mod, S-meter shift-adj	1.8	1.85	1.9	V
	VSMFM-4	50dB μ V, pin 44 DC output non-mod		3.0		V
	VSMFM-5	80dB μ V, pin 44 DC output non-mod			4.5	V
S-meter AC pin DC output	VSMFM-A1	No input, pin 57 DC output non-mod			0.45	V
	VSMFM-A2	10dB μ V, pin 57 DC output non-mod		0.63		V
	VSMFM-A3	30dB μ V, pin 57 DC output non-mod	1.15	1.45	1.75	V
	VSMFM-A4	50dB μ V, pin 57 DC output non-mod		2.45		V
	VSMFM-A5	80dB μ V, pin 57 DC output non-mod			4.5	V
S-meter inclination standard - 1	S-curve1	Which was obtained by deducting (VSMFM-2) from VSM (VSMFM-3)	0.85	1.0	1.4	V
S-meter inclination standard - 2	S-curve2	Which was obtained by deducting (VSMFM-3) from VSM (VSMFM-4)	0.8	1.15	1.5	V
Mute drive output	VMUTE-60	60dB μ V, pin 64 output DC output non-mod		0.15	0.3	V
Noise convergence - 1	FM NOISE-20	60dB μ V.98.1MHz, 30%mod, input reference, output level of the input -20dB μ V, MUTE = OFF (42pin = GND)	-12	-7	-3	dB
N-AGC ON input	VNAGC	98.1MHz, non-mod, MIX input level at which pin 13 becomes 0.6V or more	64	69	74	dB μ V
W-AGC ON input	VWAGC	98.1MHz, non-mod, pin 44 = 0V applied (Keyed on), MIX input level at which pin 13 becomes 0.6V or more	80	88	96	dB μ
Image obstruction ratio	IRR	Removal amount of 108.1M +21.4MHz (when IRR-DAC is used)	40			dB
SD bandwidth	BW-mute	98.1MHz, non-mod, 60dB μ V, Bandwidth at which SD pin is turned ON	70	100	130	kHz
Conversion gain (MIX+1 st IF AMP)	A.V.	98.1MHz, 60dB μ V, non-mod, FECF output	93	97	101	dB μ V

[FM IF Filter characteristics] FM IF input

Parameter	Symbol	Conditions	min	typ	max	Unit
IF variable filter gain	FIL-Gain	10.7MHz, non-mod, 70dB μ V, pin 44-S-meter voltage (FILTER TEST MODE). Narrow-Fix		1.9		V
IF variable filter narrow-band characteristics	FIL-BW-N	10.7MHz \pm 30kHz, non-mod, 70dB μ Pin 44 S-meter voltage (Filter test mode). Narrow-Fix mode. Difference from Pin 44 voltage at 10.7 MHz		0.3		V
IF variable filter wide-band characteristics	FIL-BW-W	10.7MHz \pm 80kHz, non-mod, 70dB μ Pin 44 S-meter voltage (Filter test mode). Wide-Fix mode. Difference from Pin 44 voltage at 10.7 MHz			0.5	V

LV25700PM

[NC block] NC input (pin 59), S-meter AC input (pin 57)

Parameter	Symbol	Conditions	min	typ	max	Unit
FM NC gate time	FM τ GATE	NC input, pulse cycle = 1kHz, 44pin = 2V applied, pulse width = 1 μ s, at 200mVp-o pulse input (after MPX-VCO adjustment), measurement at pin 24.	36	40	44	μ s
FM NC noise sensitivity	SN-DETOUT	NC input (pin 59), 44pin = 2V applied, measure the pulse input level at which the noise canceller starts operation, pulse cycle = 1kHz, pulse width = 1 μ s	95	130	165	mVp-o
FM NC noise sensitivity	SN-Vsm	S-meter (AC) input (pin 57), 44pin = 0V applied, measure the pulse input level at which the noise canceller starts operation, pulse cycle = 1kHz, pulse width = 1 μ s		90		mVp-o
AM NC gate time	AM τ GATE (1)	S-meter (AC) input (pin 57), pulse cycle = 1kHz, pulse width = 1 μ s, measurement at pin 24. 44pin = 1.5V	270	390	510	μ s
AM NC noise sensitivity	SN	S-meter (AC) input (pin 57), measure the pulse input level at which the noise canceller starts operation, pulse cycle=1kHz, pulse width=1 μ s		220		mVp-o

[Multipath-noise rejection circuit] MRC input (pin 58)

Parameter	Symbol	Conditions	min	typ	max	Unit
MRC output	VMRC	Pin 56 voltage when 3.5 V is applied to V44	2.7	2.95	3.2	V
MRC operation level	MRC-ON	SG (AG5) out level when pin 44 = 3.5V and pin 56 = 2.6V, f = 70kHz	110	155	220	mVrms

[AM characteristics] AM AMANT input

Parameter	Symbol	Conditions	min	typ	max	Unit
Practical sensitivity	S/N-30	1MHz, 30dB μ V, fm = 1kHz, 30%mod, pin 49	20			dB
Detection output	Vo-AM	1MHz, 74dB μ V, fm = 1kHz, 30%mod, pin 49	130	180	250	mVrms
AGC-F.O.M	V AGC-FOM	1MHz, 74dB μ V, output reference, input width at which the output decreases by 10dB, pin 49	52	56	60	dB
Signal-to-noise ratio	S/N-AM	1MHz, 74dB μ V, fm = 1kHz, 30%mod	51	60		dB
Total harmonic distortion ratio - 1	THD-AM-1	1MHz, 74dB μ V, fm = 1kHz, 80%mod		0.3	1	%
Total harmonic distortion ratio - 2	THD-AM-2	1MHz, 120dB μ V, fm = 1kHz, 80%mod		0.5	1.5	%
AM HCC output attenuation	AM HCC	1MHz, 74dB μ V, fm = 3kHz, 30%mod, V78 = 3V \rightarrow 0.6V, 25 pin	-13	-9	-5	dB
S-meter DC output	VSMAMDC-1	No input, 44 pin DC output	0	0.1	0.5	V
	VSMAMDC-2	1MHz, 30dB μ V, non-mod, 44 pin DC output	0.7	1.3	1.9	V
	VSMAMDC-3	1MHz, 120dB μ V, non-mod, 44 pin DC output	2.4	3.0	4.2	V
S-meter AC output	VSMAMAC-1	1MHz, -20dB μ V, fm = 1kHz, 80%mod, 57 pin DC output		0	0.5	mVrms
	VSMAMAC-2	1MHz, 74dB μ V, fm = 1kHz, 80%mod, 57 pin DC output	90	140	180	mVrms
Wide band AGC sensitivity	W-AGC.AM	1.4MHz, input at V6 = 0.7V	86	92	98	dB μ V
SD sensitivity	SD-sen.AM	1MHz, ANT input level at which the SD pin is turned ON	25	30	35	dB μ V
IF count sensitivity	IF-count-sens. AM	IF count sensitivity, 1MHz, non-mod			22	dB μ V

LV25700PM

Pin Function

Pin No.	Function name	Block
1	MIX-OUT1	FE
2	RF-V _{CC} _8V	---
3	AM-MIX-IN2	AM
4	AM-MIX-IN1	AM
5	AM-RFAGC	AM
6	AM-ATT	AM
7	FM-RFDAC	FE
8	AM-IFAGC/FM-RFAGC	AM/FM
9	FM-ANTDAC	FE
10	FM-IN1	PLL
11	FM-IN2	PLL
12	RF-GND2	PLL
13	FM-ANT-D	FE
14	VCO-GND	---
15	OSC-V _{CC}	---
16	AM/FM-OSC(B)	FE
17	AM/FM-OSC(C)	FE
18	SIGNAL QUARITY	IF
19	VT	PLL
20	AM/FM FET	PLL
21	CPAM	PLL
22	CPFM	PLL
23	FET GND	PLL
24	DC MONITOR	MPX
25	F3	LOGIC
26	UL/IFEND/BUSY	LOGIC
27	SD_OUT/ST_IND	---
28	Q_OUT	MPX
29	RD_DA	LOGIC
30	RD_CL	LOGIC
31	S_DA	LOGIC
32	S_CK	LOGIC
33	RESET	LOGIC
34	BUS(TP34)	LOGIC
35	D_V _{CC} _5V	---
36	VREG_3V	---
37	D_GND	---
38	XTAL_OUT	X'tal
39	XTAL_IN	X'tal
40	XTAL_GND	---

Pin No.	Function name	Block
41	RDS_LPF	IF
42	F2	LOGIC
43	F1	LOGIC
44	S-METER	IF
45	AFC-OUT.	IF
46	AFC-C	IF
47	Noise-AGC	NC
48	GND	---
49	MPX Lch-OUT	MPX
50	MPX Rch-OUT	MPX
51	CHCC	MPX
52	MPX_IN	MPX
53	NC-MPX-V _{CC}	---
54	Phase_dat	MPX
55	Phase_dat	MPX
56	MRC-TIME	MRC
57	VSM-AC	IF
58	MRC-IN	MRC
59	NC-IN	NC
60	DET-OUT	IF
61	VREG49	AM/FM
62	AM-IF-IN1	AM
63	AM-IF-IN2	AM
64	MUTE-CONT	IF
65	IFAGC-LPF	FE
66	AM_LC/Pilot-Det.	AM
67	Sep.-ADJ	MPX
68	AM-MIX2	AM
69	2 nd -MIXIN2	AM
70	2 nd -MIXIN1	AM
71	Mod.-DET	NC
72	IF-GND	---
73	1 st -IF-OUT	FM
74	IF-V _{CC} -5V	---
75	1 st -IF-IN1	FE
76	1 st -IF-IN2	FE
77	AM-RF-AGC	AM
78	HCC-CONT	AM/FM
79	RFAGC-IN BYPASS	FE
80	MIX-OUT2	FE

LV25700PM

Block Diagram

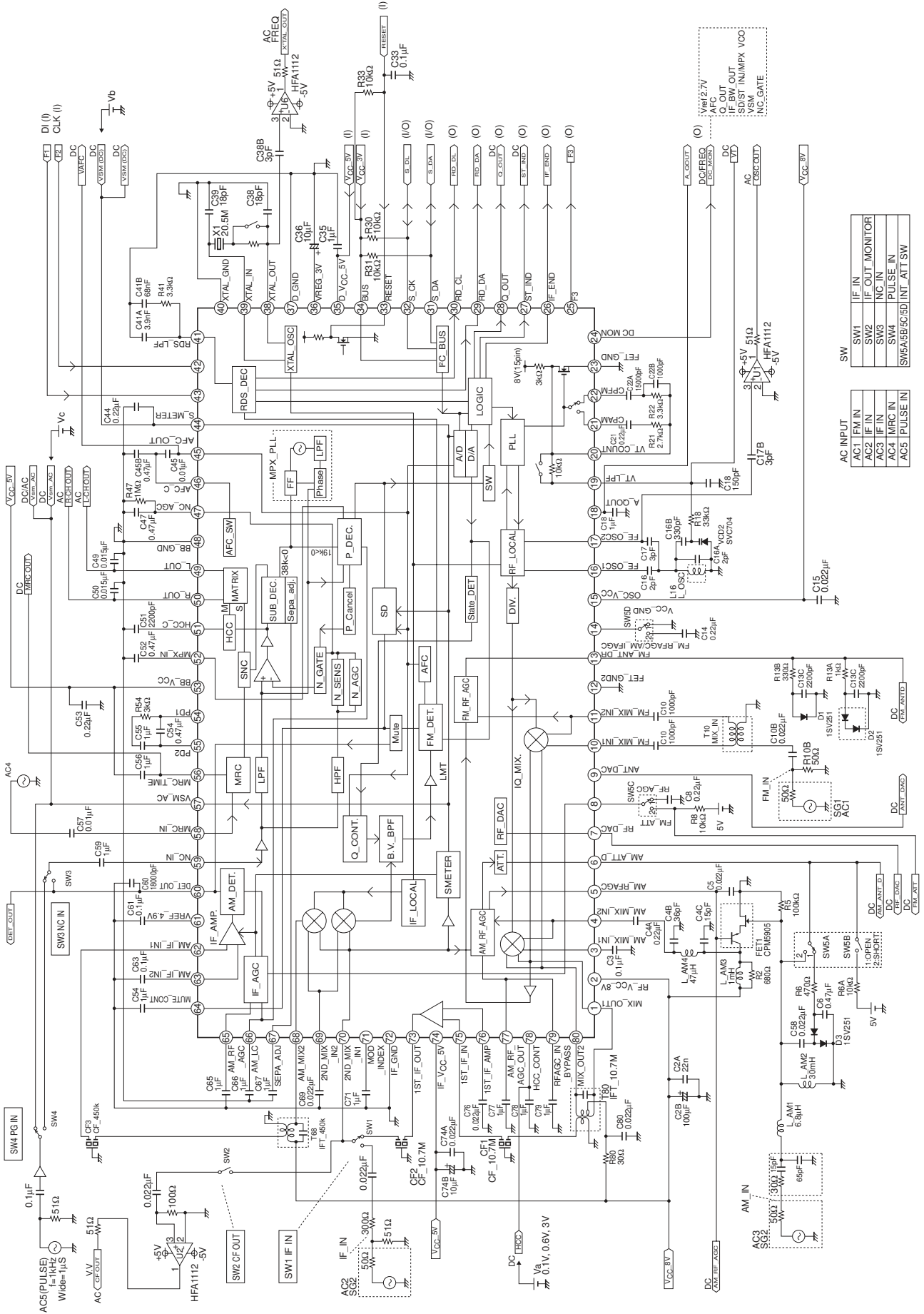

LV25700PM

Pin Discription

Pin name	Function	Discription	Internal Equivalent Circuit
1 80	MIXER OUT1 MIXER OUT1	FM/AM MIX OUT (common)	
2	RF V _{CC}		V _{CC} = 8V
3 4	AM MIXER input 1 AM MIXER input 2	AM MIX IN Input impedance = 10kΩ	
5	AM RF AGC	RF AGC rectifier capacitor Determination of distortion ratio during low-frequency modulation Increase C5; Distortion → improved Response → slow Decrease C5; Distortion → worse Response → quick	
6	AM ANT ATT	For pin diode drive I ₆ = 8mA ANT damping current	

Continued on next page.

LV25700PM

Continued from preceding page.

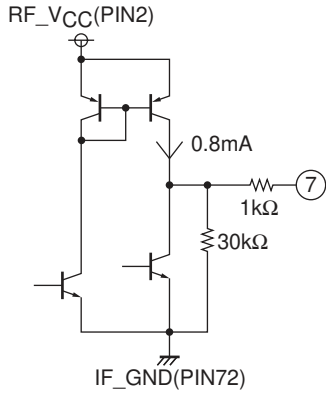
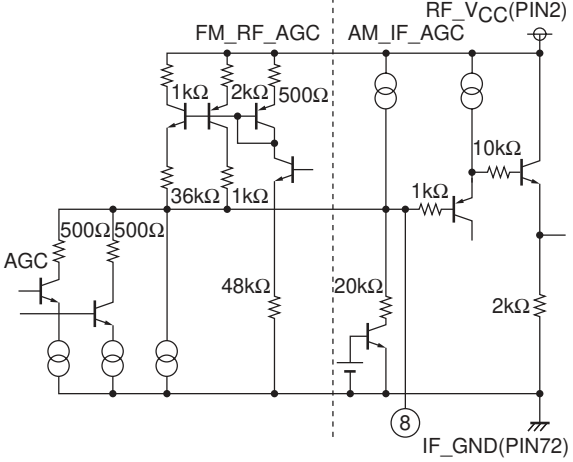
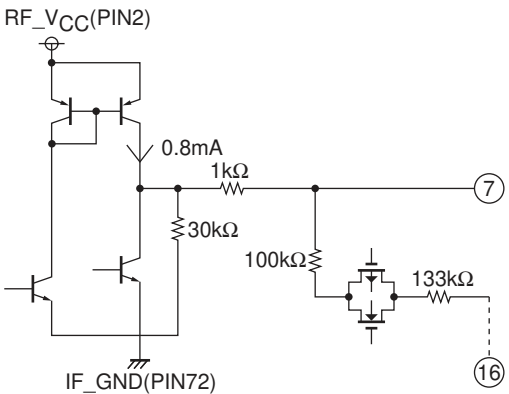
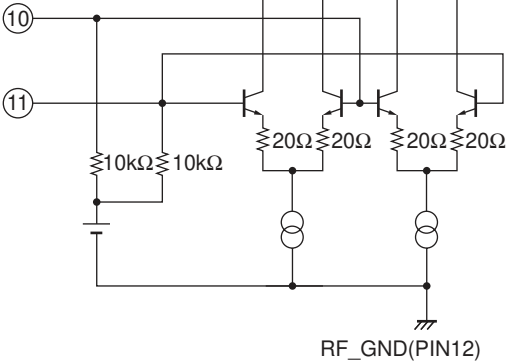
Pin name	Function	Discription	Internal Equivalent Circuit
7	FM-RF-DAC	FM RF tuning DAC	
8	AM IF AGC FM RF AGC	<p>IF AGC voltage: DC smoothing capacitor pin</p> <p>FM RF AGC voltage: Voltage = Hi (around 8V) with AGC OFF. The voltage lowers when a level is inserted into the AGC circuit. AGC is applied at the voltage of $V_{CC}-V_{be}$.</p>	
9	FM-ANT-DAC (IRR-DAC)	<p>FM ANT tuning DAC</p> <p>Can be used as an IRR-DAC selected with a changeover switch.</p>	
10 11	FM MIXER IN1 FM MIXER IN2	FM MIX input	
12	RF GND2	(FE, FM, AM)	RF GND

Continued on next page.

LV25700PM

Continued from preceding page.

Pin name	Function	Discription	Internal Equivalent Circuit
13	Antenna Damping Drive pin	Pin 13: Antenna damping current flows when the RF AGC voltage becomes $V_{CC} - V_{be}$.	
14	VCO_GND		GND
15	OSC V _{CC}	(OSC)	$V_{CC} = 8V$
16 17	OSC1 OSC2	OSC pin	
18	SIGNAL QUARITY (UNDESIRE DET)	DC smoothing is performed by the output impedance and external capacity. Note that too large capacity will reduce the responsiveness of the IF filter as the voltage of this pin is also used to control the IF filter.	

Continued on next page.

LV25700PM

Continued from preceding page.

Pin name	Function	Discription	Internal Equivalent Circuit
19 20 21 22 23	VT LPFD CPAM CPFM FET_GND	<p>LPFD: Internal FET drain output pin for PLL This pin is combined with CPM/CPAM pins to form a low pass filter for PLL.</p> <p>CPFM, CPAM: Charge pump output pins These pins are placed in high-impedance state in BACKUP mode, at power-on-reset time, and in PLL stop state.</p>	
24	DC MONITOR	<p>Adjustment mode Internal signal output monitor pin See BIT specifications.</p> <p>Normal mode: This pin outputs the SD signal.</p>	
25 26 42 43	F3 UL/IFEND/BUSY F2 F1	<p>F3 This pin must be left open. Output port</p> <p>UL/IFEND/BUSY: These pin generates the signal that identifies the Radio PLL-Unlock, IF count end, or I²C BUS Busy state.</p> <p>F1, F2 These pins must be left open. Default pull-down ON.</p>	
27 28 31 32	SD_OUT/ST_IND Q_OUT S_DA S_CK	<p>SD_OUT/ST_IND SD, ST_IND signal output pin QOUT</p> <p>Quality-out signal output pin SDA, SCK</p> <p>I²C interface pins. Both are of open drain type. External pull-up resistors are needed. Use the same power supply for the pull-up resistors and Pin 34 BUS. These pins are set to an input port at RESET time.</p>	

Continued on next page.

LV25700PM

Continued from preceding page.

Pin name	Function	Discription	Internal Equivalent Circuit
29 30	RD_DA RD_CL	RDS demodulator signal output pins Output Low when the RDF is OFF.	<p style="text-align: center;">RD_DA, RD_CL pin</p>
33	RESET	System reset pin A low-level to this pin resets the system and PC starts executing the program from address 0. When power is turned on, it is necessary to apply low-level to this pin for 50ms or more after the 8V/5V power supply is stabilized (leaving this pin open is inhibited). See the RESET timing diagrams.	
34 35 37	BUS D_VCC_5V D_GND	Power/GND pins • BUS: Power supply for the main microcontroller interface pins. • DVCC5V, GDND: Main operating power supply	
36	VREG_3V	Internal operating low-voltage output pin Connect a bypass capacitor to this pin.	
38 39 40	XTAL_OUT XTAL_IN XTAL_GND	Pins connected to the 20.5MHz oscillating element XTAL_GND: X'tal oscillator circuit GND	
41	RDS_LPF	Low pass filter for RDS VCO Used to form an external low pass filter	
44	AM/FM S_METER (DC)	Current drive type S-meter output Pin 44: Eliminates the AC component by external capacity. Pin 57: Leaves the AC components (Pin for NC noise extraction and for neighboring interfering noise extraction)	

Continued on next page.

LV25700PM

Continued from preceding page.

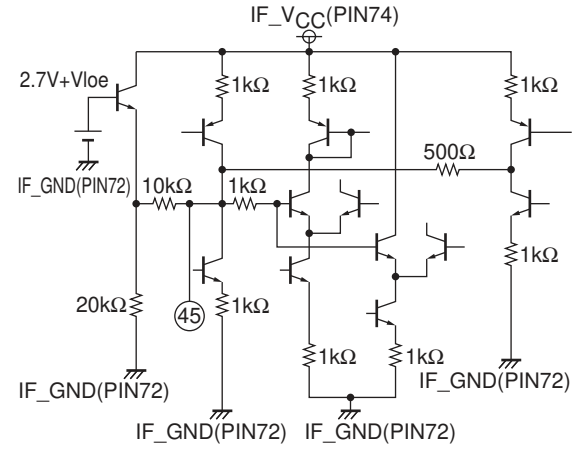
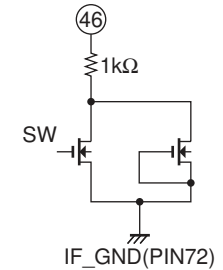
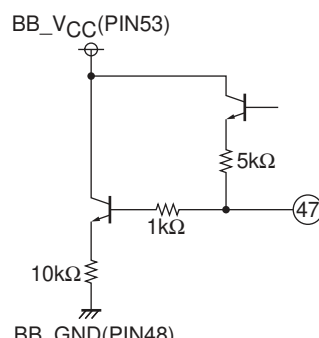
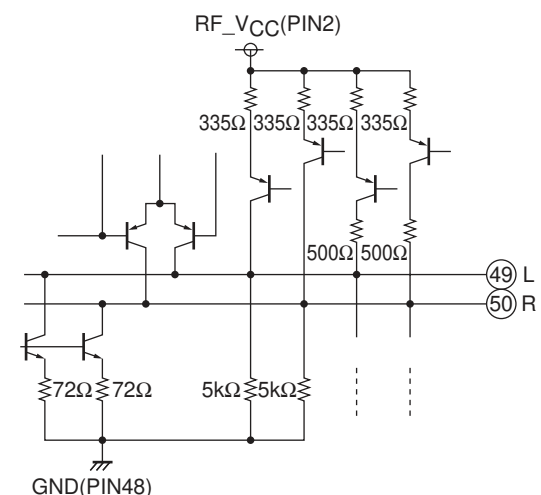
Pin name	Function	Discription	Internal Equivalent Circuit
45	AFC_OUT	Null voltage As compared with internal 2.7V regulator.	
46	AFC_C	At reception SW-ON Shorts between pin 45 and AFC capacity. (series, small capacity shorted) At RDS SW-OFF Opens between pin 45 and AFC capacity. (series, small capacity + large capacity configuration)	
47	NOISE AGC MOS: NCAGCO		
48	GND	(NC, MPX, MRC)	GND
49 50	MPX output (LEFT) MPX output (RIGHT)	MPX outputs Impedance changed over with the de-emphasis changeover. Low = 3.3kΩ High = 5.0kΩ (50/75μs changeover with the external capacity of 0.015μs)	

Continued on next page.

LV25700PM

Continued from preceding page.

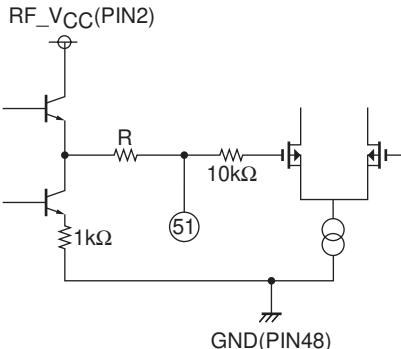
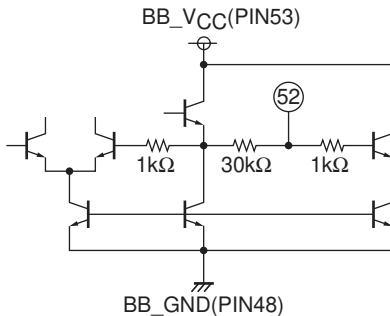
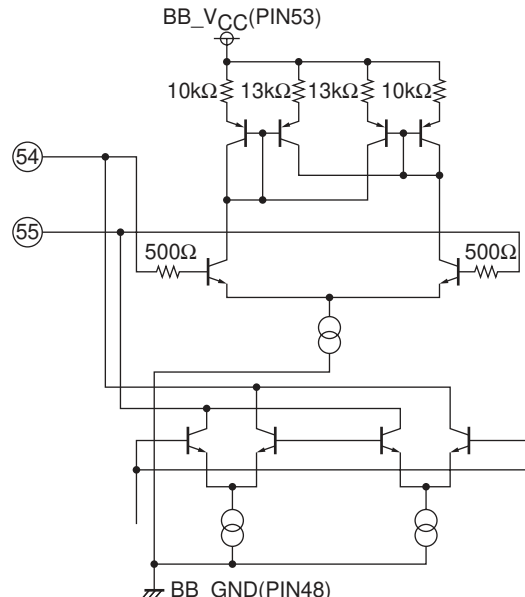
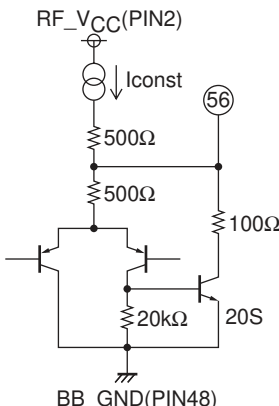
Pin name	Function	Discription	Internal Equivalent Circuit
51	HCC capacitor pin	<p>With pin 51 external capacity and internal resistor R, high-cut frequency characteristics are set.</p> <p>Internal resistance can be changed over with 3 bits (10kΩ, 30kΩ, 50kΩ, 70kΩ, 90kΩ, 110kΩ, 130kΩ, 150kΩ) (HCC cut off)</p>	
52	MPX PLL input	<p>LPF formed with internal resistance 30kΩ and pin 34 external capacity</p> <p style="text-align: center;">↓</p> <p>HPF formed by subtracting the above LPS passage signal from the Composite signal.</p> <p style="text-align: center;">↓</p> <p>Supply to MPX PLL circuit</p>	
53	NC MPX V _{CC}	(NC, MPX, MRC)	V _{CC} = 5V
54 55	Phase-Comparator for MPX		
56	MRC TIME	<p>The time constant for the Multipath-Noise Detector is determined with the following:</p> <p>100Ω resistor and external capacity during discharge</p> <p>IConstant and external capacity during charge.</p> <p>IConstant can be changed over with 2bits (MRC time constant).</p>	

Continued on next page.

LV25700PM

Continued from preceding page.

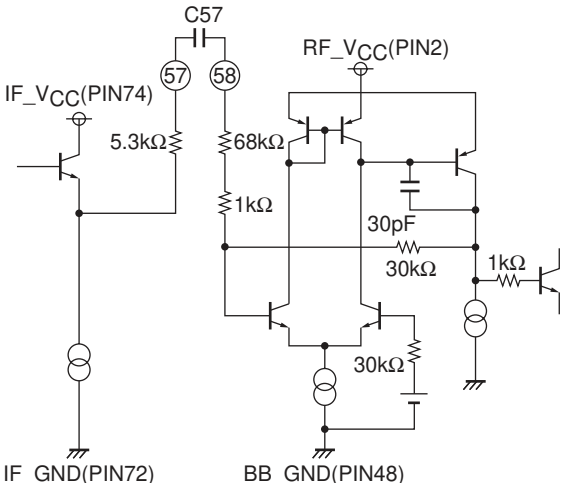
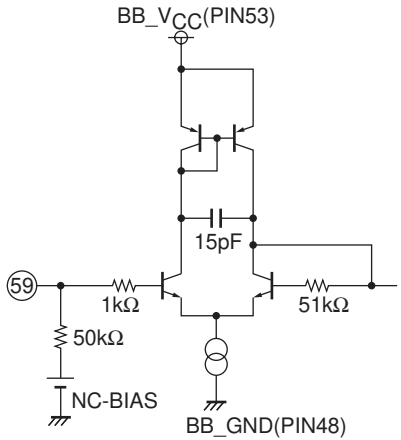
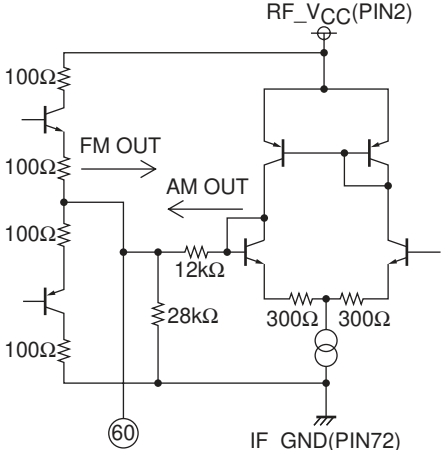
Pin name	Function	Discription	Internal Equivalent Circuit
57 58	Vsm AC MRC input		
59	Noise canceller input	Noise Canceller Input Input impedance 50kΩ	
60	FM/AM DET OUT	AM/FM detection output Output impedance Low impedance in the FM mode 12kΩ in the AM mode	

Continued on next page.

LV25700PM

Continued from preceding page.

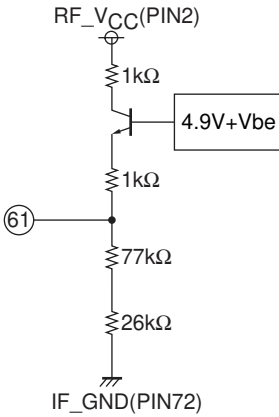
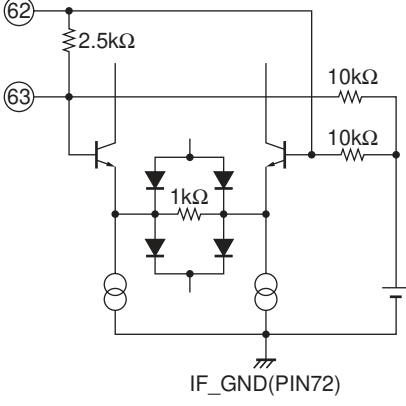
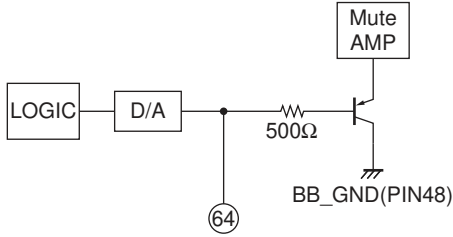
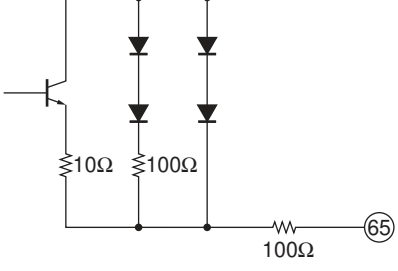
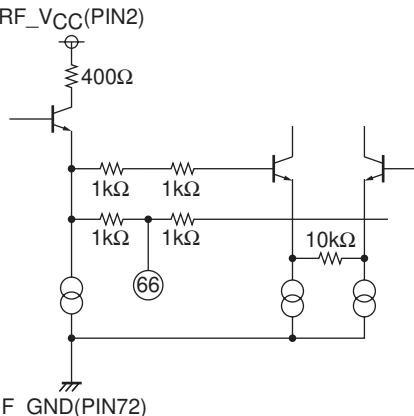
Pin name	Function	Discription	Internal Equivalent Circuit
61	VREF 4.9V	Reference voltage	
62 63	AM IF AMP input1 AM IF AMP input2	AM 450kHz AMP input Input impedance = 2kΩ	
64	MUTE CONT	Noise convergence adjustment Mute OFF function MUTE is turned OFF when pin 64 is short-circuited with GND.	
65	IF AGC LPF	Time constant changeover at Seek switch diode	
66		Frequency characteristics of unnecessary voice band of 100Hz or less is changed to produce the clear sound in the AM mode.	

Continued on next page.

LV25700PM

Continued from preceding page.

Pin name	Function	Discription	Internal Equivalent Circuit
67	SEPA ADJ	The input level of sub-decoder is varied through BIT control. (The output level of MONO and MAIN remains unchanged.) (Separation Control)	
68	AM 2 nd MIXER output	The mixer coil connected to the pin 68 mixer output must be wired to V _{CC} = 8V.	
69 70	FM 2 nd MIXER input1 FM 2 nd MIXER input2	FM 2 nd MIXER 10.7MHz → 450kHz FM AMP (10.7MHz) AMP for S-meter voltage AM MIXER input AMP for AM Noise AGC pickup	
71	Modulation INDEX	Set the detection output level as DC output. C71 is the smoothing capacitor.	
72	IF GND	(IF)	IF GND

Continued on next page.

LV25700PM

Continued from preceding page.

Pin name	Function	Discription	Internal Equivalent Circuit
73	AM/FM 1st IF MIXER AMP output	Output impedance = 330Ω	
74	IF V _{CC}	(IF)	V _{CC} = 5V
75 76	AM/FM 1st IF MIXER AMP input	AM/FM 450kHz AMP Input impedance = 330Ω	
77	AM RF AGC	RF AGC rectifier capacitor Determination of the distortion ratio during low-frequency modulation Increase C77: Distortion → improved Response → slow Decrease C77: Distortion → worse Response → quick * Same as pin 79.	
78	HCC control input pin	With the Pin 78 input voltage, attenuation of the high pass component is controlled. ↓ At weak input, high pass is cut to reduce the noise feeling. • Same control for FM/AM HCC. • The f-characteristics are set by changing over the external capacity (Pin 51) and internal resistor. • Threshold can be controlled with 5 bits. (FM/AM HCC DAC).	
79	AM RF AGC BYPASS	RF AGC rectifier capacitor Determination of the distortion ratio during low-frequency modulation Increase C77: Distortion → improved Response → slow Decrease C77: Distortion → worse Response → quick * Same as pin 77.	
80	MIXER OUT2	* See pin 1 description.	

LV25700PM

FM/AM level Diagram

FM FE

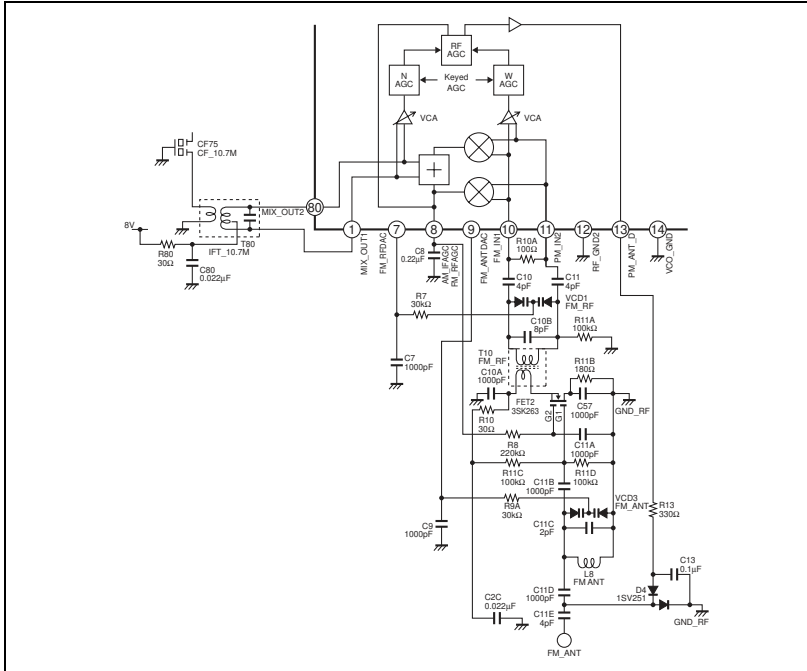

RF AGC

- Narrow AGC pick up
MIX OUT(4bit adj)
- Wide AGC pick up
MIX IN (10,11pin)(4bit adj)
- Keyed AGC
Controls narrow and wide AGC (4-bit adjustment) using the S-meter (Pin 44).

MIX

Image rejection Mixer(4bit adj)

1st IF (10.7MHz)

FM IF

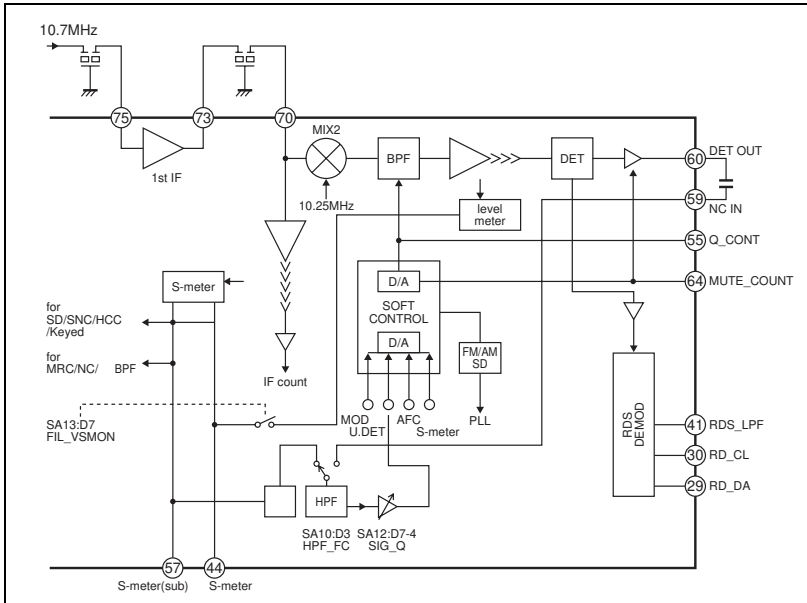

- S-meter (10.7MHz)
- 2nd IF (450kHz)
- BPF (40kHz to 180kHz automatic control)
Detection path
→ S-meter sub/Det out/AFC modulation index
- S-meter for BPF (dedicated to filter adjustment)
- IF count freq (10.7MHz)
- IF Limiter AMP
- Band SD
- Soft Mute
- RDS Decoder

LV25700PM

(2) IF filter neighboring interference detection

There are two detection block systems. The S-meter AC component is detected in the weak electric field (S-meter voltage = 2V or less), and neighboring interference is detected from DET OUT in the medium electric field or more (S-meter voltage = 2V or more).

The detection path is changed inside the IC according to the electric field.

S-meter AC component detection only or DETOUT block detection path only can also be changed by BIT at all electric fields.

The BPF consists of a HPF with $f_c = 100\text{kHz}$ (4th order) and an LPF with $f_c = 100\text{kHz}$ (1st order). The HPF can be selected from 50 or 100kHz, and the LPF f_c can be lowered by adding a capacity to the S-meter AC (Pin 57).

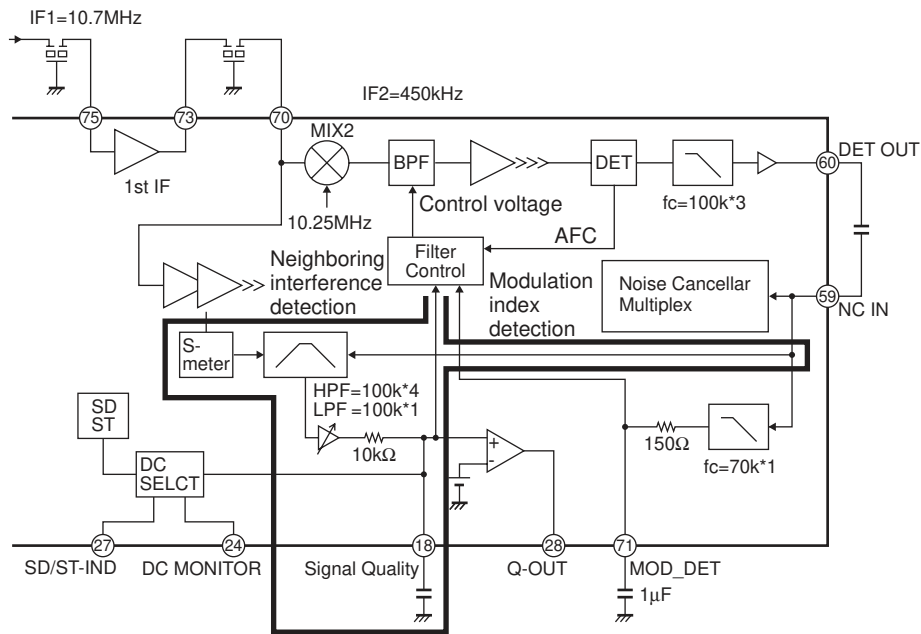

(3) IF filter AFC detection

The IF filter band is controlled by changing the AFC voltage (Pin 45).

The AFC voltage is generated by converting the frequency offset relative to the IF frequency (450kHz) to a voltage.

Neighboring interference detection responds even when the desired signal and the interference signal are the same level, but AFC detection responds when the interference signal level is higher than that of the desired signal.

Therefore, AFC detection is used in an auxiliary manner for portions that cannot be detected by the neighboring interference detection path.

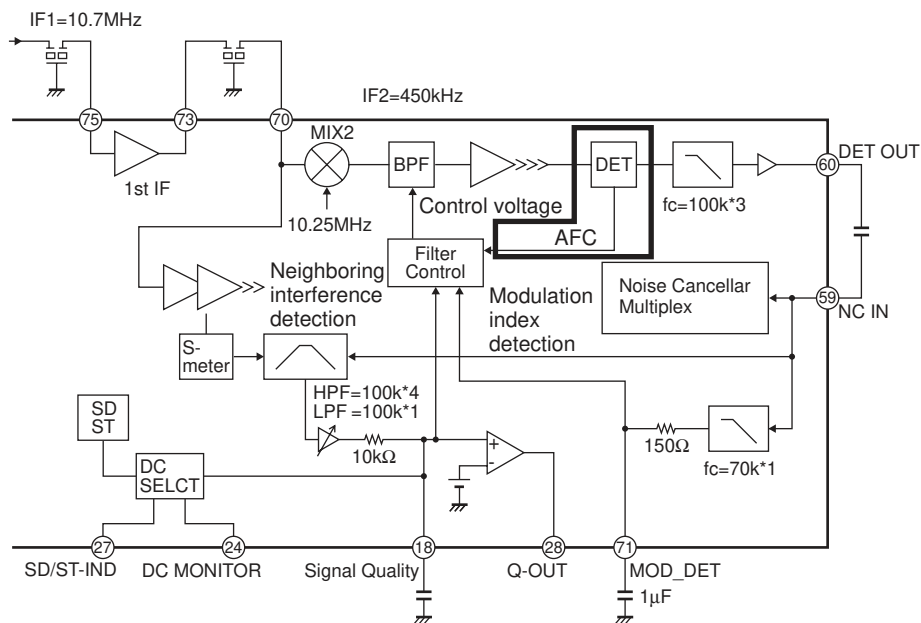

LV25700PM

Signal Quality

Signal quality uses the same path as neighboring interference detection. (The path can be changed by BIT.)

- Detection block (Smeter_AC/DETOUT) switching inside the IC according to the electric field
- Smeter_AC detection fixed at all electric fields
- DETOUT detection fixed at all electric fields

There are two output systems as follows:

- The neighboring interference detection voltage is compared by the comparator to generate the quality output (Q-OUT: Pin 28).
- The neighboring interference detection voltage is output in a linear manner (Signal Quality: Pin 18).

Signal Quality (Pin 18) performs DC smoothing using the output impedance ($1k\Omega$) and an external capacity. This pin voltage is also used to control the IF filter, so care must be taken as the IF filter response will become slow if the capacitance value is too large.

The S-meter path performs detection from before the BPF (IF filter), so there is no difference in the quality output due to filter band fluctuation.

The DET OUT (Pin 59) path performs detection from after the BPF (IF filter), so filter band fluctuation produces a difference in the quality output.

(The multipath signal is detected by Smeter_AC, so differences do not easily occur in Q-OUT.)

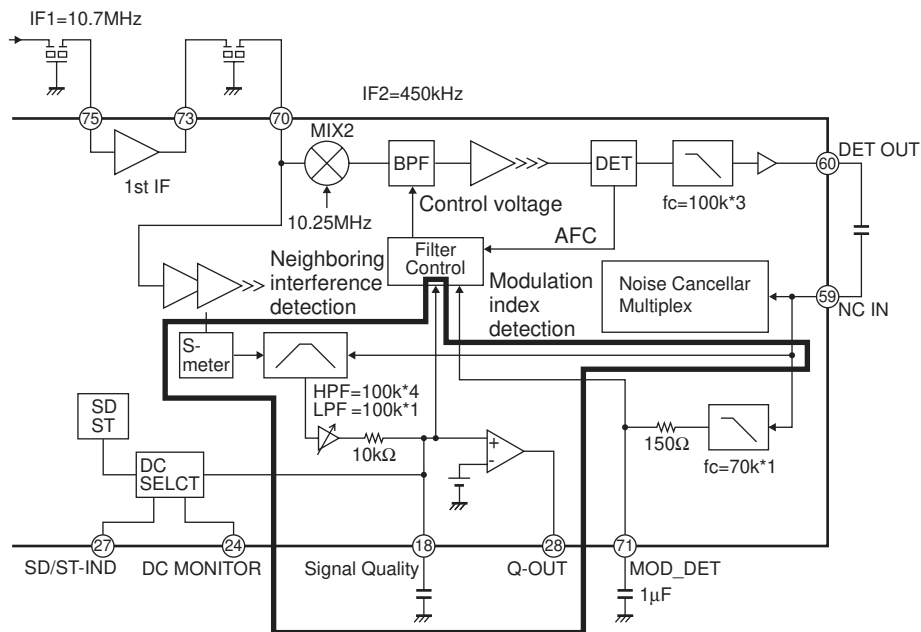

AM FE

1. AM RF AGC

The AM RF AGC system comprises two systems: N-AGC and W-AGC.

Narrow AGC: Picks up from the 2nd MIX input.

The band to which AGC is applied is determined by the bands of the two front-end ceramic filters.

Wide AGC: Picks up from the RF block, so AGC is applied to a wide bandwidth.

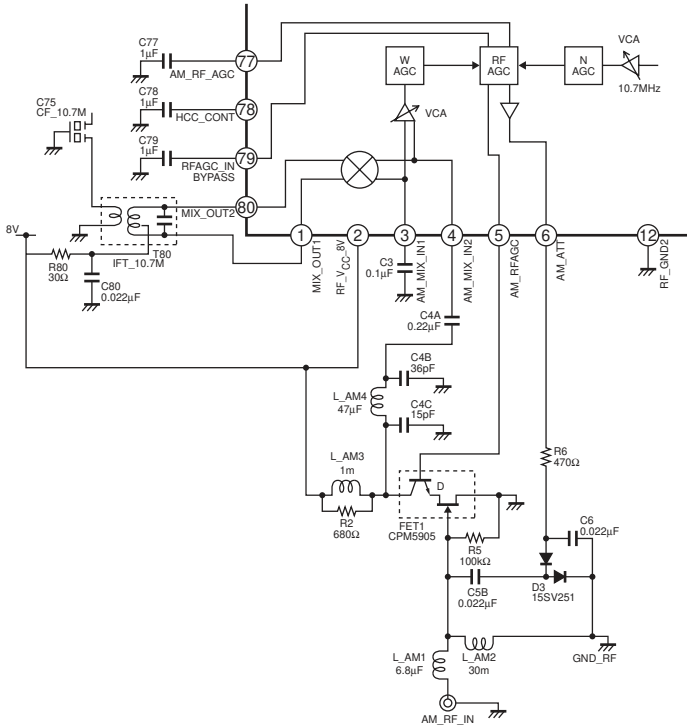

AM RF AGC band characteristics (reference characteristics)

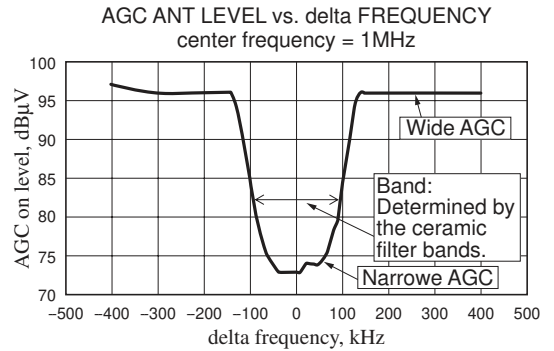

2. AM high band cut and detection output level adjustment method

The pin 60 AM and FM tuner output has an impedance of 12kΩ in AM mode and a hundred and several tens of ohms in FM mode.

The high band is pre-adjusted by the internal low pass filter (550kΩ/80pF) and the AM detection output level is pre-adjusted by the internal resistor (voltage-divided by 28kΩ). To further lower the AM band, frequency characteristics can be adjusted with capacitor C60. To lower the AM detection output level, the level can be adjusted with resistor R60.

* The high band and the output level cannot be raised from the initial status.

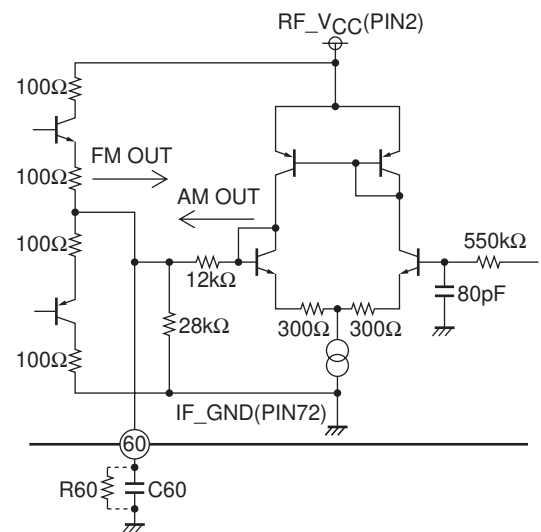

3. AM low band cut adjustment method

The AM low band frequency characteristics can be adjusted with capacitor C66, which is inserted between pin 66 and GND.

$$F_c = 1/[2\pi \times 1k\Omega \times C56]$$

* In FM mode this is shared with PILOT DET, so a capacitance value less than 0.47µF cannot be set.

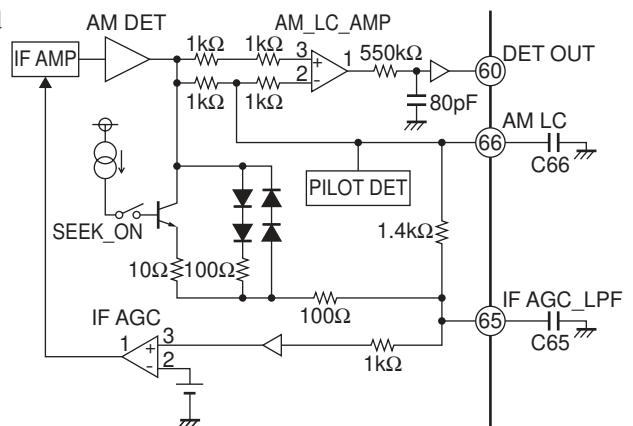

LV25700PM

Mixer/VCO/PLL

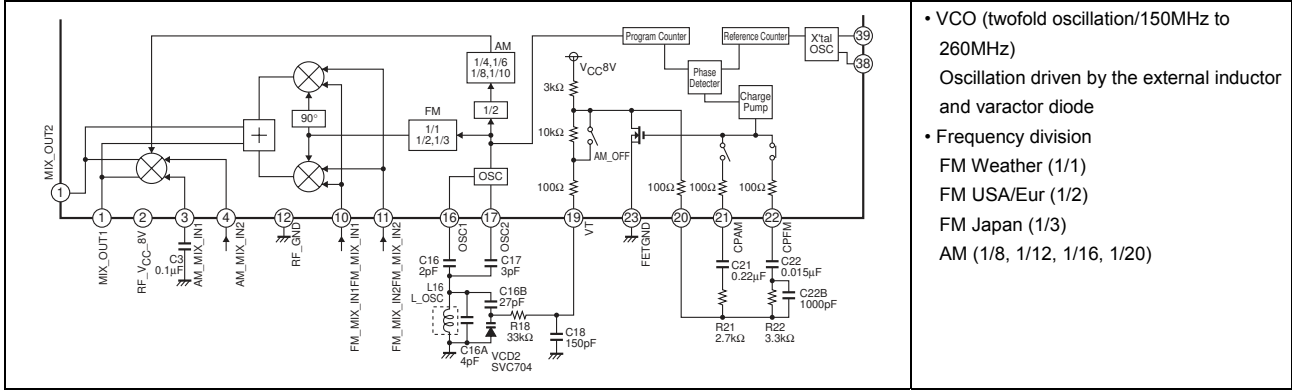

- VCO (twofold oscillation/150MHz to 260MHz)
Oscillation driven by the external inductor and varactor diode
- Frequency division
FM Weather (1/1)
FM USA/Eur (1/2)
FM Japan (1/3)
AM (1/8, 1/12, 1/16, 1/20)

FM OSC Frequencies vs. Frequency Division Ratios

Destination	RF Frequency Range (kHz)	Channel Step (kHz)	Reference Frequency (kHz)	Frequency Division Ratio
USA	87.9 to 108.1	200	100	2
EUROPE	87.5 to 108.0	50	100	2
EAST EUROPE	64 to 74	10	10	3
JAPAN	76 to 90	100	100	3
Weather Band	162.4 to 162.55	25	25	1

AM OSC

MW	RF Frequency Range (kHz)	Channel Step (kHz)	Reference Frequency (kHz)	Frequency Division Ratio
USA	520 to 1710	10	10	20 (AM/FM: 1/2 × AM: 1/10)
EUROPE	522 to 1611	9	10	20 (AM/FM: 1/2 × AM: 1/10)
JAPAN	522 to 1629	9	10	20 (AM/FM: 1/2 × AM: 1/10)

LW	RF Frequency Range (kHz)	Channel Step (kHz)	Reference Frequency (kHz)	Frequency Division Ratio
EUROPE	146 to 281	1	10	20 (AM/FM: 1/2 × AM: 1/10)

SW	RF Frequency Range (kHz)	Channel Step (kHz)	Reference Frequency (kHz)	Frequency Division Ratio
SW1	2.28 to 6.23	5	5	12 (AM/FM: 1/2 × AM: 1/6)
SW2	7.1 to 10.5	5	5	12 (AM/FM: 1/2 × AM: 1/6)
SW3	10.55 to 18	5	5	12 (AM/FM: 1/2 × AM: 1/4)

* The setting of the frequency division ratio may differ due to the varactor and coil used in OSC.

LV25700PM

FM Noise cancellar

FM noise canceller detection is performed using two systems (Pin 57 (S-meter AC), Pin 59 (NC IN)) as a countermeasure against operation errors due to the weak electric field NC sensitivity setting. The detection path is switched according to the electric field by the S-meter (DC) (Pin 44). FM NC operation can be monitored by the Pin 24 trigger out.

	Electric field strength (weak to medium)	Medium to strong
Pin 57 (S-meter AC) detection:	ON	ON
Pin 59 (CN IN):	OFF	ON

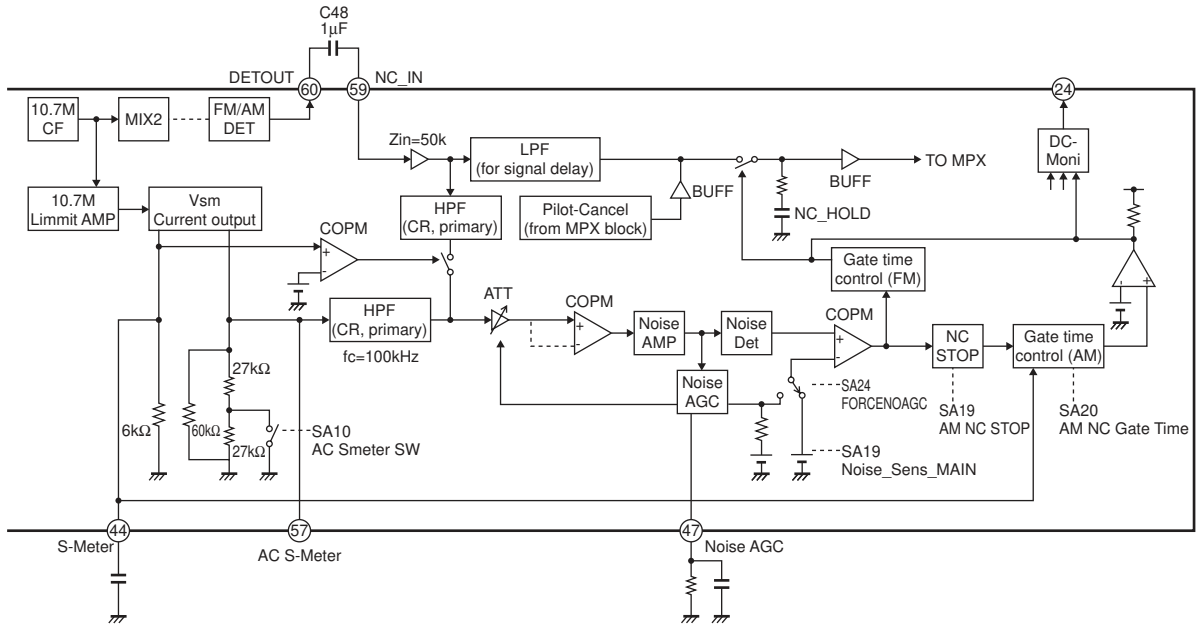

Description of FM NC functions

SA : D		Recommended Setting	Description of Functions
SA24 D2	Nose-AGC Th. Forced noise AGC	[1]Force Noise AGC	0: Fixes the noise detection sensitivity. 1: Uses noise AGC in the forcibly applied state. The noise detection sensitivity can be adjusted by DAC (SA09, D0 to D4) control.
SA18 D6-D7	Noise-Sens. NC load switching	[0] 15kΩ	The noise detection sensitivity is adjusted by switching the noise amplifier output load.
SA10 D1	AC S-Meter NC sensitivity switching (Fixed to normal)	[0] 54kΩ	Reduces the AC-S-meter internal load resistance value by approximately half. (54kΩ//60kΩ → 27kΩ//60kΩ) 0: Normal (Internal load = 54kΩ//60kΩ) 1: ON (Internal load = 27kΩ//60kΩ) However, note that in FM mode the MRC and IF filter also operate by detecting the AC component of the same pin (AC_Vsm), so these functions are affected by this bit.
SA09 D0-D4	NC SENS MAIN Adjusting the NC noise detection sensitivity	[18]	This is valid only in reception mode. However, it is invalid when SA24 D2 is set to OFF (normal). When SA24 D2 is ON Increasing the DAC setting increases the comparator threshold voltage, and worsens the noise detection sensitivity. Conversely, reducing the DAC setting enhances the detection sensitivity. (However, reducing the DAC setting by too much increases the chances of operation errors.)

LV25700PM

AM NC block

This block detects noise from the 10.7 MHz CF out, turns OFF the AM demodulated signal waveform only during the period affected by noise, and holds the DC. The detection path is the one system of Pin 40 (S-meter AC). AM NC operation can be monitored by the Pin 24 trigger out. The Pin 47 external constant is determined by the FM NC with priority.

SA:D		Recommended Setting	Description of Functions
SA24 D2	Nose-AGC Th. Forced noise AGC	[1]Force Noise AGC	0: Fixes the noise detection sensitivity. 1: Uses noise AGC in the forcibly applied state. The noise detection sensitivity can be adjusted by DAC (SA09, D0 to D4) control.
SA22 D4-D7	FIFGAIN	[9]	Sets the IF limiter amplifier gain. Increasing the DAC setting increases the gain. Reducing the DAC setting reduces the gain.
SA11 D0-D4	S-meter Shift	[29]	Hides the noise detected by VsmAC. Increasing the DAC setting increases the shift amount. Reducing the DAC setting reduces the shift amount. Reducing the shift amount enhances the effects during weak input, but also increases the chances of operation errors due to weak input noise.
SA10 D1	AC S-Meter NC sensitivity switching	[1] 27kΩ	Reduces the AC-S-meter internal load resistance value by approximately half. (54kΩ/60kΩ → 27kΩ/60kΩ) 0: Normal (Internal load = 54kΩ/60kΩ) 1: ON (Internal load = 27kΩ/60kΩ) However, note that in FM mode the MRC and IF filter also operate by detecting the AC component of the same pin (AC_Vsm), so these functions are affected by this bit.
SA18 D6-D7	Noise-Sens. NC load switching	[2] 6kΩ	The noise detection sensitivity is adjusted by switching the noise amplifier output load.
SA09 D0-D4	NC SENS MAIN Adjusts the NC noise detection sensitivity	[15]	This is valid only in reception mode. However, it is invalid when SA24 D2 is set to OFF (normal). When SA24 D2 is ON Increasing the DAC setting increases the comparator threshold voltage, and worsens the noise detection sensitivity. Conversely, reducing the DAC setting enhances the detection sensitivity. (However, reducing the DAC setting by too much increases the chances of operation errors.)
SA19 D0-D4	AM NC STOP	[31]	Can be set to operate only at weak input (forced OFF at strong input). Increasing the DAC setting → Operates up to strong input. Reducing the DAC setting → Operates only at weak input.
SA20 D2-D7	AM NC gate	[12] 430μsec (Reference value)	Can set the gate time. Increasing the DAC setting shortens the gate time. Reducing the DAC setting lengthens the gate time.
SA24 D6	AM NC OFF	[0]	Can forcibly set AM NC to OFF. 0 = ON → Normal operation 1 = OFF → Forcibly OFF

* AM NC ON/OFF can be set by the DAC [AM NC OFF].

* The NC sensitivity coarse adjustment can be set by the DAC [AC_Smeter Sw] and the DAC [Noise-Sens].

* The NC sensitivity fine adjustment can be set by the DAC [NC SENS MAIN], the DAC [S-Meter Shift] and the DAC [FM IF GAIN].

* The gate time can be set by the DAC [AM NC gate].

The ANT-IB-LEVEL range at which AM NC turns ON can be set by the DAC [AM NC stop].

(AM NC can be turned OFF at medium and strong input.)

LV25700PM

Stereo Decoder

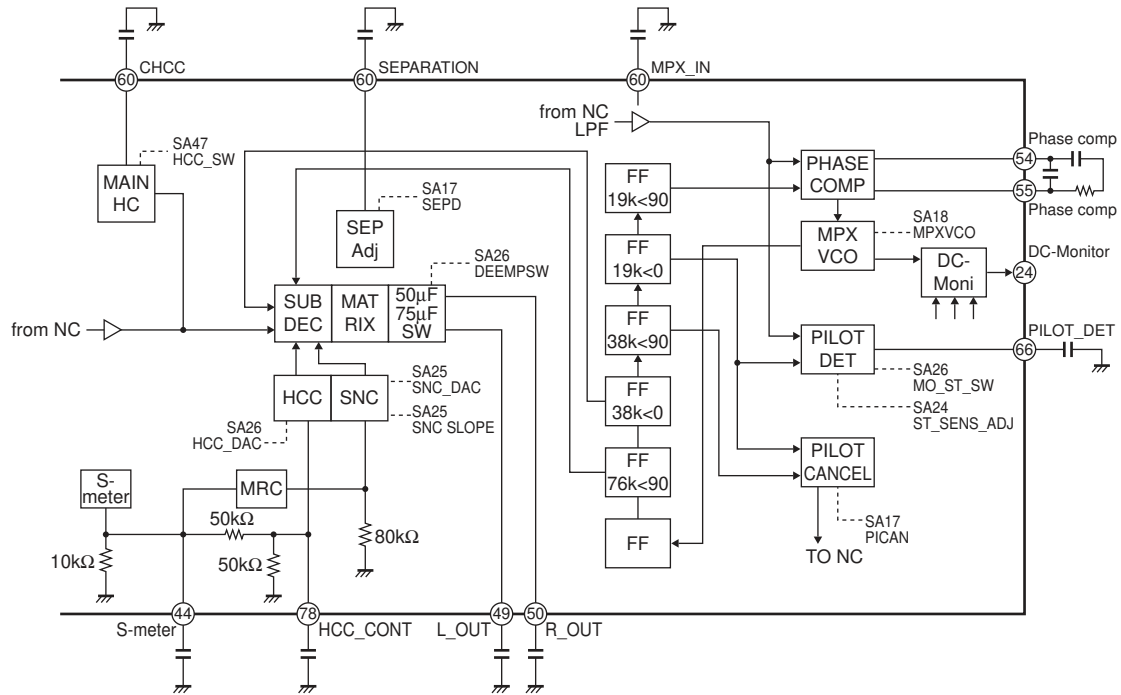

SA:D		Recommended Setting	Description of Functions
SA18 D0-D5	MPV VCO	FM:*	Optimum value: Set so that the free-running frequency (VCO frequency under no-modulation conditions) is near 304kHz (adjust to within ± 2 kHz). * Set VCO ON (SA24: D4) to [1] during adjustment.
SA26 D6	Force MONO	[0]	0 = Normal: Normal mode, 1 = Force MONO: Forced monaural
SA17 D0-D5	Separation Control	Process adjustment required	Optimum value: Adjust to maximize separation at the standard electric field input.
SA24 D3	ST-Sens ADJ	FM:[0]	0 = OFF (normal), 1 = ON (ST ON sensitivity increased) When set to ON, the ST ON sensitivity (ON/OFF) is increased by approximately 1% compared to when set to OFF.
SA17 D6-D7	Pi-Can(Pilot Cancel Level Control)	FM:[0]	[Pi-Can] Typical value: Center (process adjustment optional)
SA25 D0-D4	SNC DAC/AM-RF-AGC Amp threshold value (steep slope side)	FM: AM:[0]	[SNC DAC] Adjust to the specified separation at medium electric field input. [AM-RF-AGC] Optimum value: Fix to [0].
SA25 D5-D6	SNC slope		Small bit value: Gentle slope, Large bit value: Steep slope * If the value is too small, SEP operation may be performed even at weak electric field input, resulting in a deteriorated ST S/N ratio.
SA26 D7	De-emphasis		Set according to the destination. 0: 50 μ sec [JPN], 1: 75 μ sec [US]
SA26 D0-D4	FM/AM HCC DAC	FM:*\br/>AM:[12]	Optimum value: Adjust to the specified frequency characteristics at weak electric field input.
SA47 D5	HCC SW	FM:[6] AM:[3]	The HCC frequency characteristics is set by the Pin 51 external capacity value and the internal resistor (adjustable). Optimum value: FM mode = [6], AM mode = [3] FM mode = 6: HCC cutoff fc = 2.2kHz (when C51 = 2,200pF) AM mode = 3: HCC cutoff fc = 800Hz (when C51 = 2,200pF)
SA24 D4	VCO ON	[0]	0: Normal mode, 1: MPX-VCO monitor test mode [Pin 24 frequency measurement] (In MPX-VCO monitor mode: Set DC SELECT SA09, D5 to D7 to SD/MPX VCO OUT.)

LV25700PM

MRC

The MRC (Multipath Rejection Circuit) controls multipath noise by detecting the AC component of the IF S-meter (AC). It consists of a noise amplifier and a detection circuit.

- Noise amplifier gain

The noise amplifier gain of the Pin 58 input is determined by the R2 and R1 resistors. (The gain can be lowered by adding an external resistor.)

The gain can be further adjusted in four steps by the MRC Sens DAC. The high band frequency characteristics can be adjusted by C57.

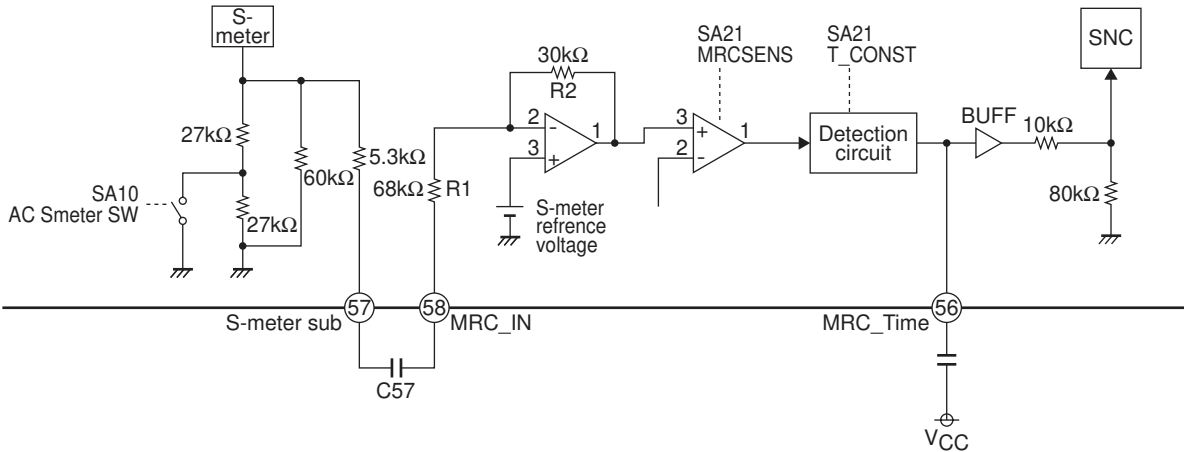

SA:D		Recommended Setting	Description of Functions
SA21 D0-D1	MRC Sensitivity	*	Optimum value: According to the specifications. Setting a smaller value enhances the sensitivity and increases the MRC amplifier gain. Setting a larger value worsens the sensitivity and reduces the MRC amplifier gain.
SA21 D2-D3	MRC Time constant (Attack/Release Time)	*	Sets the recovery time constant when the multipath countermeasure circuit operates. (Time from the MONO status to ST recovery) Setting a smaller value shortens the recovery time, and setting a larger value lengthens the recovery time.

- Detection circuit

MRC the time constant used to control separation is as follows.

Discharge: Determined by 100Ω and C56.

Charge: Determined by I56 and C56.

* I56 can be set in four steps by the MRC time constant DAC.

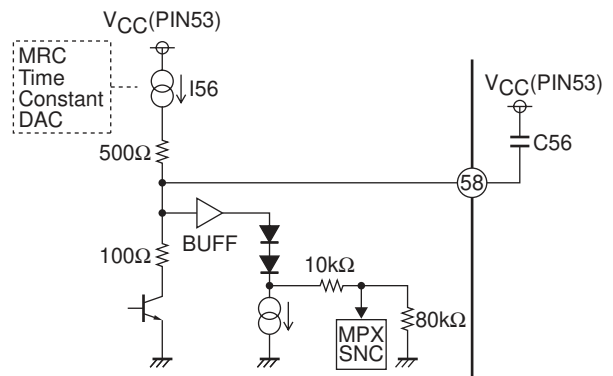

MRC time constant (reference values)

DAC	C56	Charge Time	Discharge Time
MRC_Time_Constant = 0	1μF	360ms	0.63ms
MRC_Time_Constant = 1	1μF	515ms	0.63ms
MRC_Time_Constant = 2	1μF	890ms	0.63ms
MRC_Time_Constant = 3	1μF	4.5s	0.63ms
DAC	C56	Charge Time	Discharge Time
MRC_Time_Constant = 0	0.47μF	215ms	0.5ms
MRC_Time_Constant = 0	1μF	360ms	0.63ms
MRC_Time_Constant = 0	2μF	790ms	0.9ms

LV25700PM

Bit Specifications

Slave address:

MSB							LSB	Function
A7	A6	A5	A4	A3	A2	A1	A0	
1	1	1	0	1	1	1	0	WRITE mode
1	1	1	0	1	1	1	1	READ mode

Sub address:

MSB							LSB	Function
A7	A6	A5	A4	A3	A2	A1	A0	
0	0	0	0	0	0	0	1	SA1
0	0	0	0	0	0	1	0	SA2
0	0	0	0	0	0	1	1	SA3
⋮	⋮	⋮	⋮	⋮	⋮	⋮	⋮	
0	1	0	1	1	1	0	1	SA93
0	1	0	1	1	1	1	0	SA94
0	1	0	1	1	1	1	1	SA95

* Continuous write is possible from an arbitrary sub address (e.g. SA12 to SA23).

* Restart is prohibited: After the STOP condition is generated, always start again from the START condition.

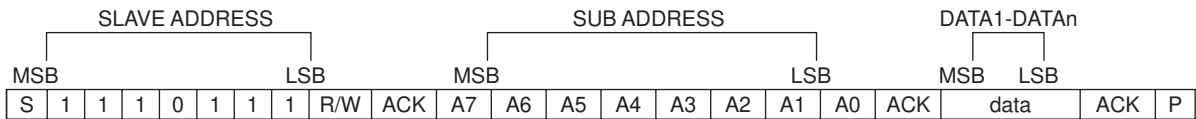

S = START
P = STOP
ACK = Acknowledge
R/W = READ / WRITE

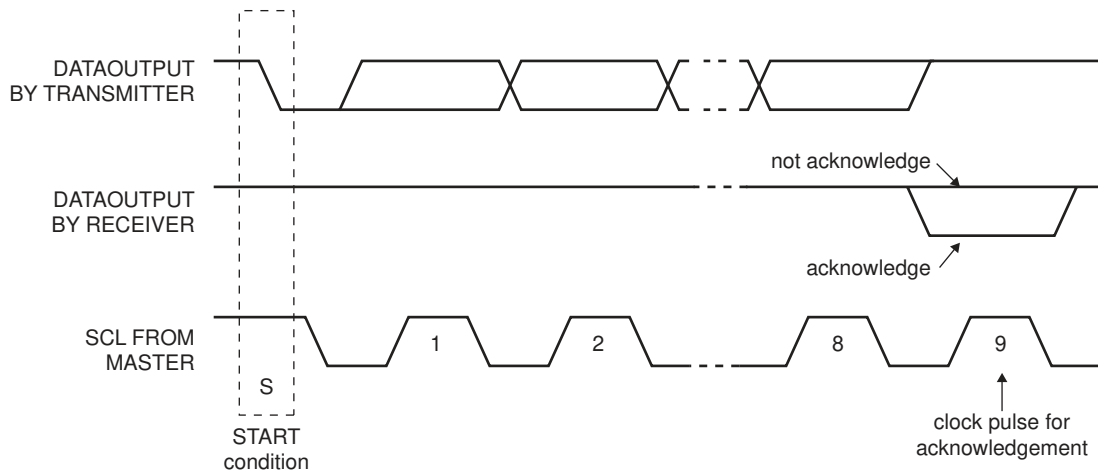
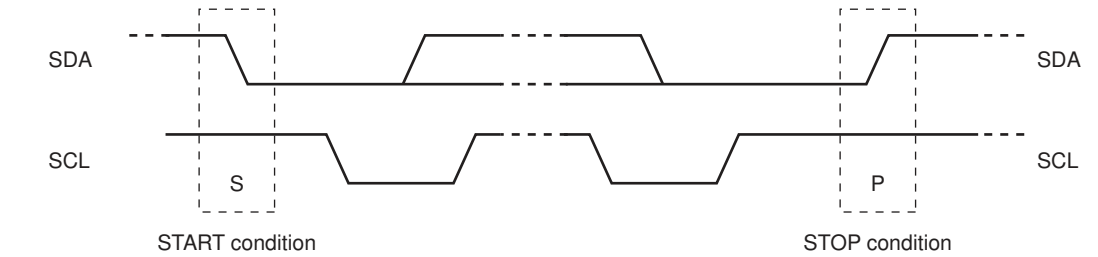

LV25700PM

SCL/SDA Bus Line Characteristics

Item	Symbol	Conditions	min	typ	max	unit
SCL clock frequency	fSCL		0		100	kHz
START condition hold time	tHD;STA		4.0			μs
STOP condition setup time	tSU;STO		4.0			μs
SCL clock Low period	tLOW		4.7			μs
SCL clock High period	tHIGH		4.0			μs
SDA and SCL signal rise time	tr				1000	ns
SDA and SCL signal fall time	tf				300	ns
Data hold time	tHD;DAT		0		2.7	μs
Data setup time	tSU;DAT		1			μs
Time from the previous STOP condition until the next START condition is generated	tBUF		BUSY = 0 to output			
Low level input voltage	V _{IL}		0		0.3V _{DD}	V
High level input voltage	V _{IH}		0.7V _{DD}		V _{DD}	V

*1: The values specified by No.1 to No.9 are the values when operating at SCL = 100kHz.

*2: No.10 is limited to the case when SA7 D7 and D6 are set to "01" or "11".

*3: The V_{DD} noted in No.11 and No.12 indicates the Pin 34 BUSV_{DD}.

*4: I²C recommended operation: Using SA03 D1 bit I²C CK Low drive.

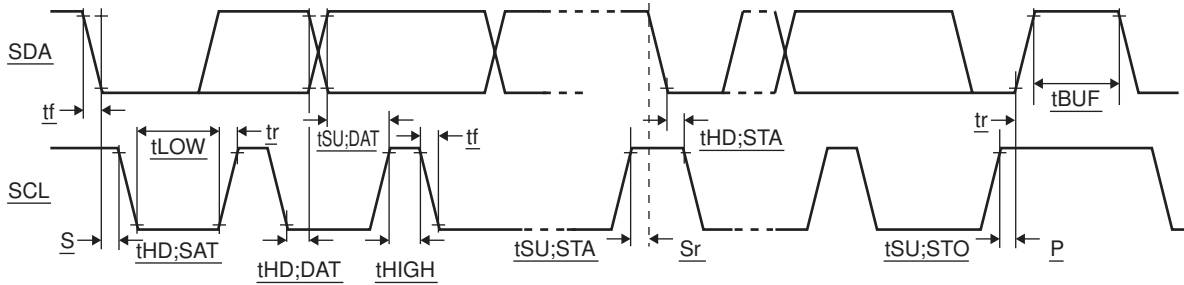

LV25700PM

BIT MAP(ES9)

SA	Sub Address	D7	D6	D5	D4	D3	D2	D1	D0
1	00000001	P15	P14	P13	P12	P11	P10	P9	P8
2	00000010	P7	P6	P5	P4	P3	P2	P1	P0
3	00000011	R3	R2	R1	R0	ULT	RDS_ON	I2C_SCK_LD	-
4	00000100	AMFM	WEATHER	OSC_DIV1	OSC_DIV0	SEEK1	SEEK0	TUNER_OFF	IQ_UP_LOW
5	00000101	RF_DAC7	RF_DAC6	RF_DAC5	RF_DAC4	RF_DAC3	RF_DAC2	RF_DAC1	RF_DAC0
6	00000110	ANT_DAC7	ANT_DAC6	ANT_DAC5	ANT_DAC4	ANT_DAC3	ANT_DAC2	ANT_DAC1	ANT_DAC0
7	00000111	UL/IFEND	BUSY	DZ1	DZ0	CTE	GT2	GT1	GT0
8	00001000	-	-	-	-	-	-	-	DIV_SW
9	00001001	DCSELCT2	DCSELCT1	DCSELCT0	NC_SENS MAIN4	NC_SENS MAIN3	NC_SENS MAIN2	NC_SENS MAIN1	NC_SENS MAIN0
10	00001010	FIL_SENS3	FIL_SENS 2	FIL_SENS 1	FIL_SENS0	HPF_FC	IN_DETOFF	NCSENSE	DAC_9OFF
11	00001011	IN_DETON	AMAGC_ON	FMAGC_ON	S_METER4	S_METER3	S_METER2	S_METER1	S_METER0
12	00001100	SIG_Q3	SIG_Q2	SIG_Q1	SIG_Q0	QDP_ADJ3	QDP_ADJ2	QDP_ADJ1	QDP_ADJ0
13	00001101	FIL_VSMON	-	CF_ADJ_D5	CF_ADJ_D4	CF_ADJ_D3	CF_ADJ_D2	CF_ADJ_D1	CF_ADJ_D0
14	00001110	-	-	BWD_ADJ_D5	BWD_ADJ_D4	BWD_ADJ_D3	BWD_ADJ_D2	BWD_ADJ_D1	BWD_ADJ_D0
15	00001111	KEY_AGC3	KEY_AGC2	KEY_AGC1	KEY_AGC0	IRR_VG3	IRR_VG2	IRR_VG1	IRR_VG0
16	00010000	NULL5	NULL4	NULL3	NULL2	NULL1	NULL0	0	0
17	00010001	PICAN1	PICAN0	SEPD5	SEPD4	SEPD3	SEPD2	SEPD1	SEPD0
18	00010010	NOISE_SEN1	NOISE_SEN0	MPXVCO_5	MPXVCO_4	MPXVCO_3	MPXVCO_2	MPXVCO_1	MPXVCO_0
19	00010011	-	-	-	AM_NC_STOP4	AM_NC_STOP3	AM_NC_STOP2	AM_NC_STOP1	AM_NC_STOP0
20	00010100	MUTEATT5	MUTEATT4	MUTEATT3	MUTEATT2	MUTEATT1	MUTEATT0	MONI MODE	REV MODE
21	00010101	-	-	AMVSM_SHIFT1	AMVSM_SHIFT0	T_CONST1	T_CONST0	MRCSENSE1	MRCSENSE0
22	00010110	FIFGAIN3	FIFGAIN2	FIFGAIN1	FIFGAIN0	AMRFAGC3	AMRFAGC2	AMRFAGC1	AMRFAGC0
23	00010111	W_AGC3	W_AGC2	W_AGC1	W_AGC0	N_AGC3	N_AGC2	N_AGC1	N_AGC0
24	00011000	MSLOPE	AM_NC_OFF	-	VCO_ON	ST_SENS_ADJ	FORCENOAGC	-	-
25	00011001	DTESTSW	SNCINC1	SNCINC0	SNC_DAC4	SNC_DAC3	SNC_DAC2	SNC_DAC1	SNC_DAC0
26	00011010	DEEMPSW	MO_ST_SW	IRR_SW	HCC_DAC4	HCC_DAC3	HCC_DAC2	HCC_DAC1	HCC_DAC0
27	00011011	-	-	-	FM_PIND_OFF	-	-	-	IFT_TRANS
28	00011100	-	-	-	SEEK_SD_ON4	SEEK_SD_ON3	SEEK_SD_ON2	SEEK_SD_ON1	SEEK_SD_ON0
29	00011101	SEEK_SD_BW3	SEEK_SD_BW2	SEEK_SD_BW1	SEEK_SD_BW0	-	-	-	-
30	00011110	-	-	-	-	-	-	-	-
31	00011111	QO_UNDDET_7	QO_UNDDET_6	QO_UNDDET_5	QO_UNDDET_4	QO_UNDDET_3	QO_UNDDET_2	QO_UNDDET_1	QO_UNDDET_0
32	00100000	QO_AFC_MAX_7	QO_AFC_MAX_6	QO_AFC_MAX_5	QO_AFC_MAX_4	QO_AFC_MAX_3	QO_AFC_MAX_2	QO_AFC_MAX_1	QO_AFC_MAX_0
33	00100001	QO_AFC_MIN_7	QO_AFC_MIN_6	QO_AFC_MIN_5	QO_AFC_MIN_4	QO_AFC_MIN_3	QO_AFC_MIN_2	QO_AFC_MIN_1	QO_AFC_MIN_0
34	00100010	QO_AFCUSE	MUTE_TC_UP_2	MUTE_TC_UP_1	MUTE_TC_UP_0	-	MUTE_TC_DOWN_2	MUTE_TC_DOWN_1	MUTE_TC_DOWN_0
35	00100011	MUTE_SMR_SLC_7	MUTE_SMR_SLC_6	MUTE_SMR_SLC_5	MUTE_SMR_SLC_4	MUTE_SMR_SLC_3	MUTE_SMR_SLC_2	MUTE_SMR_SLC_1	MUTE_SMR_SLC_0
36	00100100	MUTE_SMR_ZERO_7	MUTE_SMR_ZERO_6	MUTE_SMR_ZERO_5	MUTE_SMR_ZERO_4	MUTE_SMR_ZERO_3	MUTE_SMR_ZERO_2	MUTE_SMR_ZERO_1	MUTE_SMR_ZERO_0
37	00100101	BPF_MOD_MAX_7	BPF_MOD_MAX_6	BPF_MOD_MAX_5	BPF_MOD_MAX_4	BPF_MOD_MAX_3	BPF_MOD_MAX_2	BPF_MOD_MAX_1	BPF_MOD_MAX_0
38	00100110	BPF_MOD_MIN_7	BPF_MOD_MIN_6	BPF_MOD_MIN_5	BPF_MOD_MIN_4	BPF_MOD_MIN_3	BPF_MOD_MIN_2	BPF_MOD_MIN_1	BPF_MOD_MIN_0
39	00100111	BPF_SMR_MAX_7	BPF_SMR_MAX_6	BPF_SMR_MAX_5	BPF_SMR_MAX_4	BPF_SMR_MAX_3	BPF_SMR_MAX_2	BPF_SMR_MAX_1	BPF_SMR_MAX_0
40	00101000	BPF_SMR_MIN_7	BPF_SMR_MIN_6	BPF_SMR_MIN_5	BPF_SMR_MIN_4	BPF_SMR_MIN_3	BPF_SMR_MIN_2	BPF_SMR_MIN_1	BPF_SMR_MIN_0
41	00101001	BPF_LIMIT_7	BPF_LIMIT_6	BPF_LIMIT_5	BPF_LIMIT_4	BPF_LIMIT_3	BPF_LIMIT_2	BPF_LIMIT_1	BPF_LIMIT_0
42	00101010	BPF_FIX_7	BPF_FIX_6	BPF_FIX_5	BPF_FIX_4	BPF_FIX_3	BPF_FIX_2	BPF_FIX_1	BPF_FIX_0
43	00101011	BPF_FIX	BPF_TC_2	BPF_TC_1	BPF_TC_0	-	-	BPF_SLOPE_1	BPF_SLOPE_0
44	00101100	AFC_MAX_7	AFC_MAX_6	AFC_MAX_5	AFC_MAX_4	AFC_MAX_3	AFC_MAX_2	AFC_MAX_1	AFC_MAX_0
45	00101101	AFC_MIN_7	AFC_MIN_6	AFC_MIN_5	AFC_MIN_4	AFC_MIN_3	AFC_MIN_2	AFC_MIN_1	AFC_MIN_0
46	00101110	-	-	-	-	-	-	-	-
47	00101111	RDS_AFC	-	HCC_SW3	HCC_SW2	HCC_SW1	-	-	-
48	00110000	-	-	-	-	-	S_METER_INT_P	RF_INT_P	IRR_INT_P
49	00110001	-	-	-	-	-	-	-	-
50	00110010	RDS_QO_UDET_7	RDS_QO_UDET_6	RDS_QO_UDET_5	RDS_QO_UDET_4	RDS_QO_UDET_3	RDS_QO_UDET_2	RDS_QO_UDET_1	RDS_QO_UDET_0

LV25700PM

SA	Sub Address	D7	D6	D5	D4	D3	D2	D1	D0
51	00110011	RF_DAC_P0_7	RF_DAC_P0_6	RF_DAC_P0_5	RF_DAC_P0_4	RF_DAC_P0_3	RF_DAC_P0_2	RF_DAC_P0_1	RF_DAC_P0_0
52	00110100	RF_DAC_P1_7	RF_DAC_P1_6	RF_DAC_P1_5	RF_DAC_P1_4	RF_DAC_P1_3	RF_DAC_P1_2	RF_DAC_P1_1	RF_DAC_P1_0
53	00110101	RF_DAC_P2_7	RF_DAC_P2_6	RF_DAC_P2_5	RF_DAC_P2_4	RF_DAC_P2_3	RF_DAC_P2_2	RF_DAC_P2_1	RF_DAC_P2_0
54	00110110	RF_DAC_P3_7	RF_DAC_P3_6	RF_DAC_P3_5	RF_DAC_P3_4	RF_DAC_P3_3	RF_DAC_P3_2	RF_DAC_P3_1	RF_DAC_P3_0
55	00110111	RF_DAC_P4_7	RF_DAC_P4_6	RF_DAC_P4_5	RF_DAC_P4_4	RF_DAC_P4_3	RF_DAC_P4_2	RF_DAC_P4_1	RF_DAC_P4_0
56	00111000	RF_DAC_P5_7	RF_DAC_P5_6	RF_DAC_P5_5	RF_DAC_P5_4	RF_DAC_P5_3	RF_DAC_P5_2	RF_DAC_P5_1	RF_DAC_P5_0
57	00111001	RF_DAC_P6_7	RF_DAC_P6_6	RF_DAC_P6_5	RF_DAC_P6_4	RF_DAC_P6_3	RF_DAC_P6_2	RF_DAC_P6_1	RF_DAC_P6_0
58	00111010	RF_DAC_P7_7	RF_DAC_P7_6	RF_DAC_P7_5	RF_DAC_P7_4	RF_DAC_P7_3	RF_DAC_P7_2	RF_DAC_P7_1	RF_DAC_P7_0
59	00111011	ANT_DAC_P0_7	ANT_DAC_P0_6	ANT_DAC_P0_5	ANT_DAC_P0_4	ANT_DAC_P0_3	ANT_DAC_P0_2	ANT_DAC_P0_1	ANT_DAC_P0_0
60	00111100	ANT_DAC_P1_7	ANT_DAC_P1_6	ANT_DAC_P1_5	ANT_DAC_P1_4	ANT_DAC_P1_3	ANT_DAC_P1_2	ANT_DAC_P1_1	ANT_DAC_P1_0
61	00111101	ANT_DAC_P2_7	ANT_DAC_P2_6	ANT_DAC_P2_5	ANT_DAC_P2_4	ANT_DAC_P2_3	ANT_DAC_P2_2	ANT_DAC_P2_1	ANT_DAC_P2_0
62	00111110	ANT_DAC_P3_7	ANT_DAC_P3_6	ANT_DAC_P3_5	ANT_DAC_P3_4	ANT_DAC_P3_3	ANT_DAC_P3_2	ANT_DAC_P3_1	ANT_DAC_P3_0
63	00111111	ANT_DAC_P4_7	ANT_DAC_P4_6	ANT_DAC_P4_5	ANT_DAC_P4_4	ANT_DAC_P4_3	ANT_DAC_P4_2	ANT_DAC_P4_1	ANT_DAC_P4_0
64	01000000	ANT_DAC_P5_7	ANT_DAC_P5_6	ANT_DAC_P5_5	ANT_DAC_P5_4	ANT_DAC_P5_3	ANT_DAC_P5_2	ANT_DAC_P5_1	ANT_DAC_P5_0
65	01000001	ANT_DAC_P6_7	ANT_DAC_P6_6	ANT_DAC_P6_5	ANT_DAC_P6_4	ANT_DAC_P6_3	ANT_DAC_P6_2	ANT_DAC_P6_1	ANT_DAC_P6_0
66	01000010	ANT_DAC_P7_7	ANT_DAC_P7_6	ANT_DAC_P7_5	ANT_DAC_P7_4	ANT_DAC_P7_3	ANT_DAC_P7_2	ANT_DAC_P7_1	ANT_DAC_P7_0
67	01000011	-	-	-	SMETER_P0_4	SMETER_P0_3	SMETER_P0_2	SMETER_P0_1	SMETER_P0_0
68	01000100	-	-	-	SMETER_P1_4	SMETER_P1_3	SMETER_P1_2	SMETER_P1_1	SMETER_P1_0
69	01000101	-	-	-	SMETER_P2_4	SMETER_P2_3	SMETER_P2_2	SMETER_P2_1	SMETER_P2_0
70	01000110	-	-	-	SMETER_P3_4	SMETER_P3_3	SMETER_P3_2	SMETER_P3_1	SMETER_P3_0
71	01000111	-	-	-	SMETER_P4_4	SMETER_P4_3	SMETER_P4_2	SMETER_P4_1	SMETER_P4_0
72	01001000	-	-	-	SMETER_P5_4	SMETER_P5_3	SMETER_P5_2	SMETER_P5_1	SMETER_P5_0
73	01001001	-	-	-	SMETER_P6_4	SMETER_P6_3	SMETER_P6_2	SMETER_P6_1	SMETER_P6_0
74	01001010	-	-	-	SMETER_P7_4	SMETER_P7_3	SMETER_P7_2	SMETER_P7_1	SMETER_P7_0
75	01001011	-	-	-	-	-	-	-	-
76	01001100	-	-	-	-	-	-	-	-
77	01001101	-	-	-	-	-	-	-	-
78	01001110	-	-	-	-	-	-	-	-
79	01001111	-	-	-	-	-	-	-	-
80	01010000	AF_P15	AF_P14	AF_P13	AF_P12	AF_P11	AF_P10	AF_P9	AF_P8
81	01010001	AF_P7	AF_P6	AF_P5	AF_P4	AF_P3	AF_P2	AF_P1	AF_P0
82	01010010	AF_RFD7	AF_RFD6	AF_RFD5	AF_RFD4	AF_RFD3	AF_RFD2	AF_RFD1	AF_RFD0
83	01010011	AF_ANTD7	AF_ANTD6	AF_ANTD5	AF_ANTD4	AF_ANTD3	AF_ANTD2	AF_ANTD1	AF_ANTD0
84	01010100	-	-	-	-	-	-	-	-
85	01010101	-	-	-	-	-	-	-	-
86	01010110	-	-	-	-	-	-	-	-
87	01010111	-	-	-	-	-	-	-	-
88	01011000	-	-	-	-	-	-	-	-
89	01011001	-	-	-	-	-	-	-	-
90	01011010	-	-	-	-	-	-	-	-
91	01011011	-	-	-	-	-	-	-	-
92	01011100	-	-	-	-	-	-	-	-
93	01011101	CUSTOM_CODE_7	CUSTOM_CODE_6	CUSTOM_CODE_5	CUSTOM_CODE_4	CUSTOM_CODE_3	CUSTOM_CODE_2	CUSTOM_CODE_1	CUSTOM_CODE_0
94	01011110	AREA_CODE3	AREA_CODE2	AREA_CODE1	AREA_CODE0	ALIGN_NO3	ALIGN_NO2	ALIGN_NO1	ALIGN_NO0
95	01011111	CHECK_SUM7	CHECK_SUM6	CHECK_SUM5	CHECK_SUM4	CHECK_SUM3	CHECK_SUM2	CHECK_SUM1	CHECK_SUM0

LV25700PM

Special Commands (SA248 and SA252 are 3 bytes, other commands have no data.)

SA	Sub Address	D7	D6	D5	D4	D3	D2	D1	D0
248	11111000	WRITE_ID2	WRITE_ID1	WRITE_ID0	Flash Memory Write Mode Set				
249	11111001	RDS MUTE ON							
250	11111010	RDS MUTE OFF							
251	11111011	Flash Memory Default							
252	11111100	WRITE_ID2	WRITE_ID1	WRITE_ID0	Flash Memory Write				
253	11111101	Normal Frequency Change(SA01,SA02,SA05) for RDS AF Search							
254	11111110	AF Frequency Change(SA80,SA81,SA82) for RDS AF Search							
255	11111111	Firmware Version Information							

LV25700PM

Bit Map (FM Initial Data)

SA	Sub Address	D7	D6	D5	D4	D3	D2	D1	D0
1	00000001	0	0	0	0	1	0	0	0
2	00000010	1	0	0	0	0	0	0	0
3	00000011	1	1	0	0	0	0	0	0
4	00000100	0	0	0	0	0	1	0	0
5	00000101	1	0	0	1	1	0	1	0
6	00000110	*	*	*	*	*	*	*	*
7	00000111	0	1	0	1	0	0	1	1
8	00001000	0	0	0	0	0	0	0	0
9	00001001	1	0	0	1	0	0	1	0
10	00001010	0	1	0	1	0	0	0	0
11	00001011	0	0	0	*	*	*	*	*
12	00001100	1	0	1	0	0	1	1	0
13	00001101	0	0	*	*	*	*	*	*
14	00001110	0	0	*	*	*	*	*	*
15	00001111	0	1	0	0	1	0	0	1
16	00010000	*	*	*	*	*	*	0	0
17	00010001	*	*	*	*	*	*	*	*
18	00010010	0	0	*	*	*	*	*	*
19	00010011	0	0	0	0	0	0	0	0
20	00010100	1	1	1	1	1	1	0	0
21	00010101	0	0	1	0	1	1	0	1
22	00010110	1	0	1	0	1	1	0	0
23	00010111	0	1	1	0	0	0	1	1
24	00011000	0	0	0	0	0	1	0	0
25	00011001	0	1	0	*	*	*	*	*
26	00011010	1	0	0	0	1	1	1	0
27	00011011	0	0	0	0	0	0	0	1
28	00011100	0	0	0	*	*	*	*	*
29	00011101	0	1	0	1	0	0	0	0
30	00011110	0	0	0	0	0	0	0	0
31	00011111	0	0	0	0	1	0	1	1
32	00100000	1	0	1	0	0	1	1	0
33	00100001	0	1	1	1	0	0	1	1
34	00100010	0	0	0	0	0	0	0	0
35	00100011	*	*	*	*	*	*	*	*
36	00100100	*	*	*	*	*	*	*	*
37	00100101	0	0	0	0	0	0	0	0
38	00100110	0	0	0	0	0	0	0	0
39	00100111	0	0	0	0	0	0	0	0
40	00101000	0	0	0	0	0	0	0	0
41	00101001	1	1	1	1	1	1	1	1
42	00101010	0	0	0	0	0	0	0	0
43	00101011	0	0	0	0	0	0	1	0
44	00101100	1	0	1	0	0	1	1	0
45	00101101	0	1	1	1	0	0	1	1
46	00101110	0	0	0	0	0	0	0	0
47	00101111	1	0	1	1	0	0	0	0
48	00110000	0	0	0	0	0	0	0	0
49	00110001	0	0	0	0	0	0	0	0
50	00110010	0	0	0	0	1	0	1	1

LV25700PM

SA	Sub Address	D7	D6	D5	D4	D3	D2	D1	D0
51	00110011	0	0	0	0	0	0	0	0
52	00110100	0	0	0	0	0	0	0	0
53	00110101	0	0	0	0	0	0	0	0
54	00110110	0	0	0	0	0	0	0	0
55	00110111	0	0	0	0	0	0	0	0
56	00111000	0	0	0	0	0	0	0	0
57	00111001	0	0	0	0	0	0	0	0
58	00111010	0	0	0	0	0	0	0	0
59	00111011	0	0	0	0	0	0	0	0
60	00111100	0	0	0	0	0	0	0	0
61	00111101	0	0	0	0	0	0	0	0
62	00111110	0	0	0	0	0	0	0	0
63	00111111	0	0	0	0	0	0	0	0
64	01000000	0	0	0	0	0	0	0	0
65	01000001	0	0	0	0	0	0	0	0
66	01000010	0	0	0	0	0	0	0	0
67	01000011	0	0	0	0	0	0	0	0
68	01000100	0	0	0	0	0	0	0	0
69	01000101	0	0	0	0	0	0	0	0
70	01000110	0	0	0	0	0	0	0	0
71	01000111	0	0	0	0	0	0	0	0
72	01001000	0	0	0	0	0	0	0	0
73	01001001	0	0	0	0	0	0	0	0
74	01001010	0	0	0	0	0	0	0	0
75	01001011	0	0	0	0	0	0	0	0
76	01001100	0	0	0	0	0	0	0	0
77	01001101	0	0	0	0	0	0	0	0
78	01001110	0	0	0	0	0	0	0	0
79	01001111	0	0	0	0	0	0	0	0
80	01010000	0	0	0	0	0	0	0	0
81	01010001	0	0	0	0	0	0	0	0
82	01010010	0	0	0	0	0	0	0	0
83	01010011	0	0	0	0	0	0	0	0
84	01010100	0	0	0	0	0	0	0	0
85	01010101	0	0	0	0	0	0	0	0
86	01010110	0	0	0	0	0	0	0	0
87	01010111	0	0	0	0	0	0	0	0
88	01011000	0	0	0	0	0	0	0	0
89	01011001	0	0	0	0	0	0	0	0
90	01011010	0	0	0	0	0	0	0	0
91	01011011	0	0	0	0	0	0	0	0
92	01011100	0	0	0	0	0	0	0	0
93	01011101	0	0	0	0	0	0	0	0
94	01011110	0	0	0	1	0	0	1	1
95	01011111	*	*	*	*	*	*	*	*

Green	*: FM adjustment
Orange	: Users should readjust as necessary. Asterisks indicate items that are already adjusted in SANYO Semiconductor's tester process. Other parameters (SA) also require readjustment when used outside SANYO Semiconductor's recommended settings.
Gray	0: System reserved

LV25700PM

Bit Map (AM Initial Data)

SA	Sub Address	D7	D6	D5	D4	D3	D2	D1	D0
1	00000001	0	1	0	1	1	0	1	1
2	00000010	0	1	1	0	1	0	0	0
3	00000011	0	1	1	1	0	0	0	0
4	00000100	1	0	0	0	0	1	0	0
5	00000101	0	0	0	0	0	0	0	0
6	00000110	0	0	0	0	0	0	0	0
7	00000111	0	1	0	1	0	0	1	1
8	00001000	0	0	0	0	0	0	0	0
9	00001001	1	0	0	0	1	1	1	1
10	00001010	0	0	0	0	0	0	1	0
11	00001011	0	0	0	1	1	1	0	1
12	00001100	0	0	0	0	0	0	0	0
13	00001101	0	0	0	0	0	0	0	0
14	00001110	0	0	0	0	0	0	0	0
15	00001111	0	1	0	1	0	0	0	0
16	00010000	0	0	0	0	0	0	0	0
17	00010001	0	0	0	0	0	0	0	0
18	00010010	1	0	0	0	0	0	0	0
19	00010011	0	0	0	1	1	1	1	1
20	00010100	0	0	1	1	0	0	0	0
21	00010101	0	0	0	0	0	0	0	0
22	00010110	1	0	0	1	1	1	0	0
23	00010111	0	1	0	0	0	1	1	1
24	00011000	0	0	0	0	0	1	0	0
25	00011001	0	0	0	0	0	0	0	0
26	00011010	1	0	0	0	1	1	0	0
27	00011011	0	0	0	0	0	0	0	0
28	00011100	0	0	0	*	*	*	*	*
29	00011101	0	0	0	0	0	0	0	0
30	00011110	0	0	0	0	0	0	0	0
31	00011111	0	0	0	0	0	0	0	0
32	00100000	0	0	0	0	0	0	0	0
33	00100001	0	0	0	0	0	0	0	0
34	00100010	0	0	0	0	0	0	0	0
35	00100011	0	0	0	0	0	0	0	0
36	00100100	0	0	0	0	0	0	0	0
37	00100101	0	0	0	0	0	0	0	0
38	00100110	0	0	0	0	0	0	0	0
39	00100111	0	0	0	0	0	0	0	0
40	00101000	0	0	0	0	0	0	0	0
41	00101001	0	0	0	0	0	0	0	0
42	00101010	0	0	0	0	0	0	0	0
43	00101011	0	0	0	0	0	0	0	0
44	00101100	0	0	0	0	0	0	0	0
45	00101101	0	0	0	0	0	0	0	0
46	00101110	0	0	0	0	0	0	0	0
47	00101111	1	0	0	1	1	0	0	0
48	00110000	0	0	0	0	0	0	0	0
49	00110001	0	0	0	0	0	0	0	0
50	00110010	0	0	0	0	0	0	0	0

LV25700PM

SA	Sub Address	D7	D6	D5	D4	D3	D2	D1	D0
51	00110011	0	0	0	0	0	0	0	0
52	00110100	0	0	0	0	0	0	0	0
53	00110101	0	0	0	0	0	0	0	0
54	00110110	0	0	0	0	0	0	0	0
55	00110111	0	0	0	0	0	0	0	0
56	00111000	0	0	0	0	0	0	0	0
57	00111001	0	0	0	0	0	0	0	0
58	00111010	0	0	0	0	0	0	0	0
59	00111011	0	0	0	0	0	0	0	0
60	00111100	0	0	0	0	0	0	0	0
61	00111101	0	0	0	0	0	0	0	0
62	00111110	0	0	0	0	0	0	0	0
63	00111111	0	0	0	0	0	0	0	0
64	01000000	0	0	0	0	0	0	0	0
65	01000001	0	0	0	0	0	0	0	0
66	01000010	0	0	0	0	0	0	0	0
67	01000011	0	0	0	0	0	0	0	0
68	01000100	0	0	0	0	0	0	0	0
69	01000101	0	0	0	0	0	0	0	0
70	01000110	0	0	0	0	0	0	0	0
71	01000111	0	0	0	0	0	0	0	0
72	01001000	0	0	0	0	0	0	0	0
73	01001001	0	0	0	0	0	0	0	0
74	01001010	0	0	0	0	0	0	0	0
75	01001011	0	0	0	0	0	0	0	0
76	01001100	0	0	0	0	0	0	0	0
77	01001101	0	0	0	0	0	0	0	0
78	01001110	0	0	0	0	0	0	0	0
79	01001111	0	0	0	0	0	0	0	0
80	01010000	0	0	0	0	0	0	0	0
81	01010001	0	0	0	0	0	0	0	0
82	01010010	0	0	0	0	0	0	0	0
83	01010011	0	0	0	0	0	0	0	0
84	01010100	0	0	0	0	0	0	0	0
85	01010101	0	0	0	0	0	0	0	0
86	01010110	0	0	0	0	0	0	0	0
87	01010111	0	0	0	0	0	0	0	0
88	01011000	0	0	0	0	0	0	0	0
89	01011001	0	0	0	0	0	0	0	0
90	01011010	0	0	0	0	0	0	0	0
91	01011011	0	0	0	0	0	0	0	0
92	01011100	0	0	0	0	0	0	0	0
93	01011101	0	0	0	0	0	0	0	0
94	01011110	0	0	0	1	0	0	1	1
95	01011111	*	*	*	*	*	*	*	*

Yellow	*: AM adjustment
Orange	: Users should readjust as necessary. Asterisks indicate items that are already adjusted in SANYO Semiconductor's tester process. Other parameters (SA) also require readjustment when used outside SANYO Semiconductor's recommended settings.
Gray	0: System reserved

LV25700PM

SA1. PLL N Value Higher-order 8 bits

D7	D6	D5	D4	D3	D2	D1	D0
P15	P14	P13	P12	P11	P10	P9	P8

MSB								LSB	Function
D7	D6	D5	D4	D3	D2	D1	D0		
0	0	0	0	0	0	0	0		
0	0	0	0	0	0	0	1		
0	0	0	0	0	0	1	0		
-	-	-	-	-	-	-	-		
1	1	1	1	1	1	0	0		
1	1	1	1	1	1	0	1		
1	1	1	1	1	1	1	0		
1	1	1	1	1	1	1	1		

SA2. PLL N Value Lower-order 8 bits

D7	D6	D5	D4	D3	D2	D1	D0
P7	P6	P5	P4	P3	P2	P1	P0

MSB								LSB	Function
D7	D6	D5	D4	D3	D2	D1	D0		
0	0	0	0	0	0	0	0		
0	0	0	0	0	0	0	1		
0	0	0	0	0	0	1	0		
-	-	-	-	-	-	-	-		
1	1	1	1	1	1	0	0		
1	1	1	1	1	1	0	1		
1	1	1	1	1	1	1	0		
1	1	1	1	1	1	1	1		

*SA1: D7 to D0 [P7 or P0] = ALL High

LV25700PM

SA3. Reference Counter Setting, RDS Control, I²C Format Switching, Flash Programming

D7	D6	D5	D4	D3	D2	D1	D0
R3	R2	R1	R0	ULT	RDS_ON	I ² C_SCK_LD	-

MSB							LSB	Function
D7	D6	D5	D4	D3	D2	D1	D0	
							0	Not used. Fixed at 0.
							0	SCK no L drive (normal mode)
							1	SCK L drive Hold SCL low until processing ends at the slave side.
					0			RDS power OFF
					1			RDS power ON
				0				PLL unlock detection time 0.39μs
				1				PLL unlock detection time 0.98μs
0	0	0	0					PLL stop
0	0	0	1					-
0	0	1	0					-
0	0	1	1					-
0	1	0	0					Ref = 5kHz
0	1	0	1					-
0	1	1	0					-
0	1	1	1					Ref = 10kHz
1	0	0	0					-
1	0	0	1					Ref = 25kHz
1	0	1	0					-
1	0	1	1					Ref = 50kHz
1	1	0	0					Ref = 100kHz

SA4. AM/FM/Weather, AM Frequency Division Setting, SEEK Mode, Tuner ON/OFF, FM Local Hi/Low

D7	D6	D5	D4	D3	D2	D1	D0
AMFM	WEATHER	OSC_DIV1	OSC_DIV0	SEEK1	SEEK0	TUNER_OFF	IQ_UP_LOW

MSB							LSB	Function
D7	D6	D5	D4	D3	D2	D1	D0	
							0	Upper Local OSC (for US/EU)
							1	Lower Local OSC (for JPN/East EU)
							0	Running
							1	Tuner OFF
				0	0			Not used.
				0	1			Receive
				1	0			Not used.
				1	1			SEEK/RDS
		0	0					AM OSC frequency division ratio setting: 1/20
		0	1					AM OSC frequency division ratio setting: 1/16
		1	0					AM OSC frequency division ratio setting: 1/12
		1	1					AM OSC frequency division ratio setting: 1/8
	0							AM/FM band
	1							Weather band (OSC = 1)
0								FM Mode
1								AM Mode

LV25700PM

SA5. FM RF 8bit DAC

D7	D6	D5	D4	D3	D2	D1	D0
RF_DAC7	RF_DAC6	RF_DAC5	RF_DAC4	RF_DAC3	RF_DAC2	RF_DAC1	RF_DAC0

MSB							LSB	Function
D7	D6	D5	D4	D3	D2	D1	D0	
0	0	0	0	0	0	0	0	RF DAC = 0.3V (min)
0	0	0	0	0	0	0	1	
-	-	-	-	-	-	-	-	↓
1	1	1	1	1	1	1	0	
1	1	1	1	1	1	1	1	RF DAC = 7.1V (max)

SA6. FM ANT 8bit DAC (IRR_ADJ)

D7	D6	D5	D4	D3	D2	D1	D0
ANT_DAC7	ANT_DAC6	ANT_DAC5	ANT_DAC4	ANT_DAC3	ANT_DAC2	ANT_DAC1	ANT_DAC0

MSB							LSB	Function
D7	D6	D5	D4	D3	D2	D1	D0	
0	0	0	0	0	0	0	0	ANT DAC = 0.3V (min)
0	0	0	0	0	0	0	1	
								↓
1	1	1	1	1	1	1	0	
1	1	1	1	1	1	1	1	ANT DAC = 7.1V (max)

SA7. IF Count Time Setting & D0 Setting

D7	D6	D5	D4	D3	D2	D1	D0
UL/IFEND	BUSY	DZ1	DZ0	CTE	GT2	GT1	GT0

MSB							LSB	Function
D7	D6	D5	D4	D3	D2	D1	D0	
					0	0	0	IF count gate time = 0.878048msec
					0	0	1	IF count gate time = 3.512195msec
					0	1	0	IF count gate time = 7.024390msec
					0	1	1	IF count gate time = 28.09756msec
					1	0	0	IF count gate time = 56.195123msec
					1	0	1	IF count gate time = 112.390244msec
				0				Counter Reset
				1				Count Start
		0	0					DZC-A
		0	1					DZC-B
		1	0					DZC-C
		1	1					DZC-D
0	0							Unlock detection: Unlock detection start = High, Lock = Low
0	1							BUSY signal: When the I ² C slave address is received = High Idling = Low
1	0							IF count end signal: When D7, D6=10: High, IF count end: Low
1	1							UL BUSY signal: Logical OR of unlock detection signal and BUSY signal is output.

LV25700PM

SA8. 1/2, 1/3 Frequency Division Setting

D7	D6	D5	D4	D3	D2	D1	D0
-	-	-	-	-	-	-	DIV_SW

MSB							LSB	Function
D7	D6	D5	D4	D3	D2	D1	D0	
							0	AM/FM band DIV 1/2 frequency division (for US/EU/East EU/SW/Weather)
							1	FM band DIV 1/3 frequency division (for Japan)
0	0	0	0	0	0	0		Not used. Fixed at 0.

SA9. DC Monitor Select/SD Adjustment

D7	D6	D5	D4	D3	D2	D1	D0
DCSELCT2	DCSELCT1	DCSELCT0	NC_SENS MAIN4	NC_SENS MAIN3	NC_SENS MAIN2	NC_SENS MAIN1	NC_SENS MAIN0

MSB							LSB	Function
D7	D6	D5	D4	D3	D2	D1	D0	
			0	0	0	0	0	Receive mode: NC sensitivity threshold value = 0.25V (detection sensitivity increase)
			0	0	0	0	1	Receive mode: NC sensitivity threshold value = 0.32V
-	-	-	-	-	-	-	-	↓
			1	1	1	1	0	Receive mode: NC sensitivity threshold value = 2.57V
			1	1	1	1	1	Receive mode: NC sensitivity threshold value = 2.65V (detection sensitivity decrease)
0	0	0						Select DC voltage output for the functions that are necessary during process adjustment. [The setting is valid when SA20: D0 = 1.] Vref 2.7V
0	0	1						Vafc
0	1	0						Undesired voltage
0	1	1						IF Filter BW OUT
1	0	0						SD/MPX VCO OUT [normally fixed bit]
1	0	1						Vsm
1	1	0						NC_GATE_OUT
1	1	1						D0 (not used)

SA10. IF Filter sens

D7	D6	D5	D4	D3	D2	D1	D0
FIL_SENS 3	FIL_SENS 2	FIL_SENS 1	FIL_SENS 0	HPF_FC	IN_DETOff	NCSENSE	DAC_9OFF

MSB							LSB	Function
D7	D6	D5	D4	D3	D2	D1	D0	
							0	RF-DAC OFF_SW = ON mode [normal: When RF/ANT-DAC is used]
							1	RF-DAC OFF_SW = OFF mode
							0	AC S-meter additional resistor = 54kΩ
							1	AC S-meter additional resistor = 27kΩ
							0	IF Filter pickup = Normal *(SA11_D7 = 0, SA10_D2 = 0)
							1	IF Filter pickup = Only VsmAC *(SA11_D7 = 0, SA10_D2 = 1)
							0	RDS HPF fc = 100kHz
							1	RDS HPF fc = 50kHz
0	0	0	0					Receive mode: IF filter sensitivity = High/at SEEK: SD bandwidth = Narrow
0	0	0	1					Receive mode: IF filter sensitivity =
								↓
1	1	1	0					Receive mode: IF filter sensitivity =
1	1	1	1					Receive mode: IF filter sensitivity = Low/at SEEK: SD bandwidth = Wide

LV25700PM

SA11. Signal Meter Adjustment/AM/FM Forced AGC ON

D7	D6	D5	D4	D3	D2	D1	D0
IN_DET0N	AMAGC_ON	FMAGC_ON	S_METER4	S_METER3	S_METER2	S_METER1	S_METER0

MSB								LSB	Function
D7	D6	D5	D4	D3	D2	D1	D0		
			0	0	0	0	0	FM Vsm (30dBμ) = 2.293V	
			0	0	0	0	1	FM Vsm (30dBμ) = 2.239V	
								↓ [AM mode: Fixed at 1DH]	
			1	1	1	1	0	FM Vsm (30dBμ) = 1.456V	
			1	1	1	1	1	FM Vsm (30dBμ) = 1.427V	
		0						FM forced RF AGC = OFF (normal)	
		1						FM forced RF AGC = ON (ANT_D ON)	
	0							AM forced RF AGC = OFF (normal)	
	1							AM forced RF AGC = ON (ANT_D ON)	
0								IF Filter pickup = Normal *(SA11_D7 = 0, SA10_D2 = 0)	
1								IF Filter pickup = Only DETOUT *(SA11_D7 = 1, SA10_D2 = 0)	

SA12. Signal Quality/FM DET PHASE

D7	D6	D5	D4	D3	D2	D1	D0
SIG_Q3	SIG_Q2	SIG_Q1	SIG_Q0	QDP_ADJ3	QDP_ADJ2	QDP_ADJ1	QDP_ADJ0

MSB								LSB	Function
D7	D6	D5	D4	D3	D2	D1	D0		
				0	0	0	0	FM DET phase = -φ	
				0	0	0	1	FM DET phase =	
								↓	
				1	1	1	0	FM DET phase =	
				1	1	1	1	FM DET phase = +φ	
0	0	0	0					Signal Quality threshold value = 0.2V	
0	0	0	1					Signal Quality threshold value = 0.34V	
								↓	
1	1	1	0					Signal Quality threshold value = 2.36V	
1	1	1	1					Signal Quality threshold value = 2.5V	

LV25700PM

SA13. Band Variable BPF (Center Frequency)

D7	D6	D5	D4	D3	D2	D1	D0
FIL_VSMON	-	CF_ADJ_D5	CF_ADJ_D4	CF_ADJ_D3	CF_ADJ_D2	CF_ADJ_D1	CF_ADJ_D0

MSB								LSB	Function	
D7	D6	D5	D4	D3	D2	D1	D0			
		0	0	0	0	0	0	303.6kHz (CF bit = 0) *Min		* Reference value
		0	0	0	0	0	1	307.6kHz (CF bit = 1)		* Reference value
		0	0	0	0	1	0	439.6kHz (CF bit = 29)		* Reference value
		0	0	0	0	0	1	444.4kHz (CF bit = 30)		* Reference value
		0	1	1	1	1	1	450kHz (Center frequency) (CF bit = 31)		* Reference value
		1	0	0	0	0	0	450kHz (Center frequency) (CF bit = 32)		* Reference value
		1	0	0	0	0	1	454.4kHz (CF bit = 33)		* Reference value
		1	0	0	0	1	0	458.8kHz (CF bit = 34)		* Reference value
		1	1	1	1	1	0	589.2kHz (CF bit = 62)		* Reference value
		1	1	1	1	1	1	594kHz (CF bit = 63) *Max		* Reference value
	0							Not used. Fixed at 0.		
0								FILTER DC (Vsm) OUT OFF		
1								FILTER DC (Vsm) OUT ON		

SA14. Band Variable BPF (Band/Gain)

D7	D6	D5	D4	D3	D2	D1	D0
-	-	BWD_ADJ_D5	BWD_ADJ_D4	BWD_ADJ_D3	BWD_ADJ_D2	BWD_ADJ_D1	BWD_ADJ_D0

MSB								LSB	Function	
D7	D6	D5	D4	D3	D2	D1	D0			
		0	0	0	0	0	0	Gain = -50dB (BW/G bit = 0) *Min		* Reference value
		0	0	0	0	0	1	Gain = dB (BW/G bit = 1)		
		0	0	0	0	1	0	Gain = dB (BW/G bit = 29)		
		0	0	0	0	0	1	Gain = dB (BW/G bit = 30)		
		0	1	1	1	1	1	Gain = 0dB (CF bit = 31)		* Reference value
		1	0	0	0	0	0	Gain = 0dB (CF bit = 32)		* Reference value
		1	0	0	0	0	1	Gain = dB (BW/G bit = 33)		
		1	0	0	0	1	0	Gain = dB (BW/G bit = 34)		
		1	1	1	1	1	0	Gain = dB (BW/G bit = 62)		
		1	1	1	1	1	1	Gain = +50dB (BW/G bit = 63) *Max		* Reference value
0	0							Not used. Fixed at 0.		

LV25700PM

SA15. Keyed AGC/IQ Mix Phase

D7	D6	D5	D4	D3	D2	D1	D0
KEY_AGC3	KEY_AGC2	KEY_AGC1	KEY_AGC0	IRR_VG3	IRR_VG2	IRR_VG1	IRR_VG0

MSB								LSB	Function
D7	D6	D5	D4	D3	D2	D1	D0		
				0	0	0	0	FM IQ MIX phase =	
				0	0	0	1	FM IQ MIX phase =	
								↓	
				1	1	1	0	FM IQ MIX phase =	
				1	1	1	1	FM IQ MIX phase =	
0	0	0	0					FM Keyed AGC threshold value = 0.14V AM IF Gain = 63dB (AGC FOM)	
0	0	0	1					FM Keyed AGC threshold value = 0.24V AM IF Gain = 62dB (AGC FOM)	
								↓	
1	1	1	0					FM Keyed AGC threshold value = 2.07V AM IF Gain = 49.5dB (AGC FOM)	
1	1	1	1					FM Keyed AGC threshold value = 2.2V AM IF Gain = 49dB (AGC FOM)	

SA16. Null Voltage

D7	D6	D5	D4	D3	D2	D1	D0
NULL5	NULL4	NULL3	NULL2	NULL1	NULL0	-	-

MSB								LSB	Function
D7	D6	D5	D4	D3	D2	D1	D0		
						0	0	Fixed (not used)	
0	0	0	0	0	0			FM Null Voltage Low 1step = +30mV	
0	0	0	0	0	1				
1	1	1	1	1	0				
1	1	1	1	1	1			FM Null Voltage High	

SA17. Pilot Cancel/Separation Adjustment

D7	D6	D5	D4	D3	D2	D1	D0
PICAN1	PICAN0	SEPD5	SEPD4	SEPD3	SEPD2	SEPD1	SEPD0

MSB								LSB	Function
D7	D6	D5	D4	D3	D2	D1	D0		
		0	0	0	0	0	0	Sub level = max	
		0	0	0	0	0	1		
								↓	
		1	1	1	1	1	0		
		1	1	1	1	1	1	Sub level = min	
0	0							Pilot cancel = Center	
0	1							Pilot cancel = Low	
1	0							Pilot cancel = High	
1	1							Pilot cancel = OFF	

LV25700PM

SA18. Noise Canceller Sensitivity/MPX_VCO

D7	D6	D5	D4	D3	D2	D1	D0
NOISE_SEN1	NOISE_SEN0	MPXVCO_5	MPXVCO_4	MPXVCO_3	MPXVCO_2	MPXVCO_1	MPXVCO_0

MSB				LSB				Function
D7	D6	D5	D4	D3	D2	D1	D0	
		0	0	0	0	0	0	MPX VCO = 227kHz
		0	0	0	0	0	1	MPX VCO = 230kHz
								↓
		1	1	1	1	1	0	MPX VCO = 369kHz
		1	1	1	1	1	1	MPX VCO = 373kHz
0	0							Noise sens = 15k
0	1							Noise sens = 20k Sens = Hi
1	0							Noise sens = 6k Sens = Low
1	1							Noise sens = 10k

SA19. AM NC STOP Sensitivity

D7	D6	D5	D4	D3	D2	D1	D0
-	-	-	AM_NC_STOP4	AM_NC_STOP3	AM_NC_STOP2	AM_NC_STOP1	AM_NC_STOP0

MSB				LSB				Function
D7	D6	D5	D4	D3	D2	D1	D0	
			0	0	0	0	0	AM NC STOP = 0.3V (= Vsm)
			0	0	0	0	1	AM NC STOP = 0.51V (= Vsm)
			1	1	1	1	0	AM NC STOP = 4.06V (= Vsm)
			1	1	1	1	1	AM NC STOP = 4.19V (= Vsm)
0	0	0						Not used. Fixed at 0.

SA20. FM Mute Adjustment (Noise Convergence Adjustment)

D7	D6	D5	D4	D3	D2	D1	D0
MUTEATT5	MUTEATT4	MUTEATT3	MUTEATT2	MUTEATT1	MUTEATT0	MONI MODE	REV MODE

MSB				LSB				Function
D7	D6	D5	D4	D3	D2	D1	D0	
							0	Normal
							1	SMETER AD READ MODE (for test monitoring)
							0	DC SELECT switching 0: SD/ST pin output [normally fixed bit]
							1	DC SELECT switching 1: Each voltage output at the DC MONI pin. [SA9: D7-D5 setting enabled]
0	0	0	0	0	0			FM MUTE attenuation = 2.0dB AM NC Gate time = 1800µs (no input)
0	0	0	0	0	1			FM MUTE attenuation = 2.4dB AM NC Gate time = 1500µs (no input)
								↓ [Fixed value in AM mode: 0CH]
0	1	1	1	1	1			FM MUTE attenuation = dB AM NC Gate time = 630µs (no input)
1	0	0	0	0	0			FM MUTE attenuation = dB AM NC Gate time = 600µs (no input)
								↓
1	1	1	1	1	0			FM MUTE attenuation = 25dB AM NC Gate time = 335µs (no input)
1	1	1	1	1	1			FM MUTE attenuation = 25dB AM NC Gate time = 330µs (no input)

LV25700PM

SA21. MRC Sensitivity, Time Constant/AM S-meter

D7	D6	D5	D4	D3	D2	D1	D0
-	-	AMVSM_SHIFT1	AMVSM_SHIFT0	T_CONST1	T_CONST0	MRCSENSE1	MRCSENSE0

MSB								LSB	Function
D7	D6	D5	D4	D3	D2	D1	D0		
						0	0	MRC sensitivity = Sens High	
						0	1		
						1	0		
						1	1	MRC sensitivity = Sens Low	
				0	0			MRC charge time = 360ms MRC discharge time = 0.63ms	
				0	1			MRC charge time = 515ms MRC discharge time = 0.63ms	
				1	0			MRC charge time = 890ms MRC discharge time = 0.63ms	
				1	1			MRC charge time = 4.5s MRC discharge time = 0.63ms	
		0	0					FM Mute SW mute_1V attenuation = 19dB AM S-meter shifter Input level = 30dB μ when Vsm = 1.5V	
		0	1					FM Mute SW mute_1V attenuation = 13dB Input level = 38dB μ when Vsm = 1.5V	
		1	0					FM Mute SW mute_1V attenuation = 8dB Input level = 46dB μ when Vsm = 1.5V	
		1	1					FM Mute SW mute_1V attenuation = 6dB Input level = 55dB μ when Vsm = 1.5V	
0	0							Not used. Fixed at 0.	

SA22. AM REAGC/FM IF Gain

D7	D6	D5	D4	D3	D2	D1	D0
FIFGAIN3	FIFGAIN2	FIFGAIN1	FIFGAIN0	AMRFAGC3	AMRFAGC2	AMRFAGC1	AMRFAGC0

MSB								LSB	Function
D7	D6	D5	D4	D3	D2	D1	D0		
				0	0	0	0	AM: RFAGC (hard) threshold value = 0.37V	
				0	0	0	1	AM: RFAGC (hard) threshold value = 0.47V	
								↓	
				1	1	1	0	AM: RFAGC (hard) threshold value = 1.94V	
				1	1	1	1	AM: RFAGC (hard) threshold value = 2.04V	
0	0	0	0					FM IF Gain = Gain Low	
0	0	0	1						
								↓	
1	1	1	0						
1	1	1	1					FM IF Gain = Gain High	

LV25700PM

SA23. Wide/Narrow AGC

D7	D6	D5	D4	D3	D2	D1	D0
W_AGC3	W_AGC2	W_AGC1	W_AGC0	N_AGC3	N_AGC2	N_AGC1	N_AGC0

MSB								LSB	Function
D7	D6	D5	D4	D3	D2	D1	D0		
				0	0	0	0	FM Narrow AGC ON = 67.8dB μ AM Narrow AGC ON = 68.0dB μ	* Reference value * Reference value
				0	0	0	1	FM Narrow AGC ON = 68.0dB μ AM Narrow AGC ON = 68.5dB μ	* Reference value * Reference value
								↓	
				1	1	1	0	FM Narrow AGC ON = 80dB μ AM Narrow AGC ON = 82.7dB μ	* Reference value * Reference value
				1	1	1	1	FM Narrow AGC ON = 81dB μ AM Narrow AGC ON = 83.6dB μ	* Reference value * Reference value
0	0	0	0					FM Wide AGC ON = 94.5dB μ AM Wide AGC ON = 89.0dB μ	* Reference value * Reference value
0	0	0	1					FM Wide AGC ON = 94.7dB μ AM Wide AGC ON = 89.3dB μ	* Reference value * Reference value
								↓	
1	1	1	0					FM Wide AGC ON = 98.1dB μ AM Wide AGC ON = 104.5dB μ	* Reference value * Reference value
1	1	1	1					FM Wide AGC ON = 98.4dB μ AM Wide AGC ON = 105.2dB μ	* Reference value * Reference value

SA24.

D7	D6	D5	D4	D3	D2	D1	D0
MSLOPE	AM_NC_OFF	-	VCO_ON	ST_SENS_ADJ	FORCENOAGC	-	-

MSB								LSB	Function
D7	D6	D5	D4	D3	D2	D1	D0		
							0	Not used. Fixed at 0.	
							0	Not used. Fixed at 0.	
					0			Force Noise AGC = OFF	
					1			Force Noise AGC = ON	
				0				Stereo ON sensitivity adjustment = 3%	
				1				Stereo ON sensitivity adjustment = 2% (ST sense up)	
			0					MPX VCO monitor = Normal	
			1					MPX VCO monitor = ON	
		0						Not used. Fixed at 0.	
	0							Normal	
	1							AM_NC_OFF	
0								SLOPE \times 2.0: Change in Mute voltage with respect to change in S-meter voltage The first slope is x1, the second slope is x4 (Limiting is set to weak electric field, but cannot reduce the noise convergence.)	
1								SLOPE \times 1.0: Change in Mute voltage with respect to change in S-meter voltage The first slope is x1, the second slope is x4 (normal)	

LV25700PM

SA25. SNC Threshold Value Adjustment

D7	D6	D5	D4	D3	D2	D1	D0
DTESTSW	SNCINC1	SNCINC0	SNC_DAC4	SNC_DAC3	SNC_DAC2	SNC_DAC1	SNC_DAC0

MSB								LSB	Function
D7	D6	D5	D4	D3	D2	D1	D0		
			0	0	0	0	0	SNC starting point threshold value = 0.7V AM RF AGC (soft) threshold value = 0.7V	
			0	0	0	0	1	SNC starting point threshold value = 0.73V AM RF AGC (soft) threshold value = 0.73V	
								↓	
			1	1	1	1	0	SNC starting point threshold value = 1.80V AM RF AGC (soft) threshold value = 1.80V	
			1	1	1	1	1	SNC starting point threshold value = 1.83V AM RF AGC (soft) threshold value = 1.83V	
	0	0						SNC slope = Gentle	
								↓	
	1	1						SNC slope = S teep	
0								DAC TEST = Normal	
1								DAC TEST = DAC TEST MODE	

SA26. De-emphasis Switching/HCC Threshold Value Adjustment

D7	D6	D5	D4	D3	D2	D1	D0
DEEMPSW	MO_ST_SW	IRR_SW	HCC_DAC4	HCC_DAC3	HCC_DAC2	HCC_DAC1	HCC_DAC0

MSB								LSB	Function
D7	D6	D5	D4	D3	D2	D1	D0		
			0	0	0	0	0	HCC starting point threshold value = 0.50V	
			0	0	0	0	1	HCC starting point threshold value = 0.53V	
								↓	
			1	1	1	1	0	HCC starting point threshold value = 0.47V	
			1	1	1	1	1	HCC starting point threshold value = 1.50V	
		0						Image rejection fine adjustment OFF [when SA6: ANT-DAC is used]	
		1						Image rejection fine adjustment ON [when SA6: IRR-DAC is used]	
	0							Forced monaural = OFF	
	1							Forced monaural = ON	
0								De-emphasis = 50μsec	
1								De-emphasis = 75μsec	

SA27. FM RF Automatic Adjustment Mode Setting

D7	D6	D5	D4	D3	D2	D1	D0
-	-	USR_RF_TUNE	FM_PIN_D_OFF	USR_NRML	-	-	IFT_TRANS

MSB								LSB	Function
D7	D6	D5	D4	D3	D2	D1	D0		
							0	Not used.	
							1	MIX TRANS mode (FM normal)	
				0	0	0		Not used. Fixed at 0.	
			1					FM PIN diode forced OFF (for experimentation)	
			0					Default setting	
0	0	0						Not used. Fixed at 0.	

* D5: Auto Tune [0: ON/1:OFF], D4: Pin D [0: Normal/1: OFF = Auto tune], D3: Counter [0: ON = At auto tune/1: OFF]

LV25700PM

SA28. At SEEK: SD Adjustment

D7	D6	D5	D4	D3	D2	D1	D0
-	-	-	SEEK_SD_ON4	SEEK_SD_ON3	SEEK_SD_ON2	SEEK_SD_ON1	SEEK_SD_ON0

MSB								LSB	Function
D7	D6	D5	D4	D3	D2	D1	D0		
0	0	0	0	0	0	0	0	At SEEK: SD ON Sensitivity = High	
0	0	0	0	0	0	0	1	↓	
								↓	
0	0	0	1	1	1	1	0	↓	
0	0	0	1	1	1	1	1	At SEEK: SD ON Sensitivity = Low	

SA29. At SEEK: SD Bandwidth

D7	D6	D5	D4	D3	D2	D1	D0
SEEK_SD_BW3	SEEK_SD_BW2	SEEK_SD_BW1	SEEK_SD_BW0	-	-	-	-

MSB								LSB	Function
D7	D6	D5	D4	D3	D2	D1	D0		
0	0	0	0	0	0	0	0	At SEEK: SD bandwidth = Narrow	
0	0	0	1	0	0	0	0	↓	
								↓	
1	1	1	0	0	0	0	0	↓	
1	1	1	1	0	0	0	0	At SEEK: SD bandwidth = Wide	

SA30. Reserved

D7	D6	D5	D4	D3	D2	D1	D0
-	-	-	-	-	-	-	-

MSB								LSB	Function
D7	D6	D5	D4	D3	D2	D1	D0		
								System reserved area	

SA31. Signal Quality Sensitivity Setting

D7	D6	D5	D4	D3	D2	D1	D0
QO_UNDDDET_7	QO_UNDDDET_6	QO_UNDDDET_5	QO_UNDDDET_4	QO_UNDDDET_3	QO_UNDDDET_2	QO_UNDDDET_1	QO_UNDDDET_0

MSB								LSB	Function
D7	D6	D5	D4	D3	D2	D1	D0		
0	0	0	0	0	0	0	0	Signal Quality sense = High (threshold value low)	
0	0	0	0	0	0	0	1	↓	
								↓	
1	1	1	1	1	1	1	0	↓	
1	1	1	1	1	1	1	1	Signal Quality sense = Low (threshold value high)	

LV25700PM

SA32. IF Band Variable AFC Control (+ Side)

D7	D6	D5	D4	D3	D2	D1	D0
QO_AFC_MAX_7	QO_AFC_MAX_6	QO_AFC_MAX_5	QO_AFC_MAX_4	QO_AFC_MAX_3	QO_AFC_MAX_2	QO_AFC_MAX_1	QO_AFC_MAX_0

MSB								LSB	Function
D7	D6	D5	D4	D3	D2	D1	D0		
0	0	0	0	0	0	0	0	Q_AFC sense = High [+side] (threshold value low) * Provide hysteresis with respect to the SA33 settings.	
0	0	0	0	0	0	0	1		
								↓	
1	1	1	1	1	1	1	0		
1	1	1	1	1	1	1	1	Q_AFC sense = Low [+ side] (threshold value high)	

SA33. IF Band Variable AFC Control (- Side)

D7	D6	D5	D4	D3	D2	D1	D0
QO_AFC_MIN_7	QO_AFC_MIN_6	QO_AFC_MIN_5	QO_AFC_MIN_4	QO_AFC_MIN_3	QO_AFC_MIN_2	QO_AFC_MIN_1	QO_AFC_MIN_0

MSB								LSB	Function
D7	D6	D5	D4	D3	D2	D1	D0		
0	0	0	0	0	0	0	0	Q_AFC sense = High [- side] (threshold value low) * Provide hysteresis with respect to the SA32 settings.	
0	0	0	0	0	0	0	1		
								↓	
1	1	1	1	1	1	1	0		
1	1	1	1	1	1	1	1	Q_AFC sense = Low [- side] (threshold value high)	

SA34. FM MUTE Time Constant Setting/Signal Quality Band Control

D7	D6	D5	D4	D3	D2	D1	D0
QO_AFCUSE	MUTE_TC_UP_2	MUTE_TC_UP_1	MUTE_TC_UP_0	-	MUTE_TC_DOWN2	MUTE_TC_DOWN1	MUTE_TC_DOWN0

MSB								LSB	Function
D7	D6	D5	D4	D3	D2	D1	D0		
0								Uses no AFC voltage information for the quality-out output.	
1								Uses AFC voltage information for the quality-out output.	
	0	0	0					MUTE time constant (UP)_ 2ms/1 step	
	0	0	1					MUTE time constant (UP)_ 8ms/1 step	
	0	1	0					MUTE time constant (UP)_ 16ms/1 step	
	0	1	1					MUTE time constant (UP)_ 32ms/1 step	
				0				Not used. Fixed at 0.	
					0	0	0	MUTE time constant (DOWN)_ 2ms/1 step	
					0	0	1	MUTE time constant (DOWN)_ 8ms/1 step	
					0	1	0	MUTE time constant (DOWN)_ 16ms/1 step	
					0	1	1	MUTE time constant (DOWN)_ 32ms/1 step	

LV25700PM

SA35. FM Limiting Sensitivity Adjustment 2

D7	D6	D5	D4	D3	D2	D1	D0
MUTE_SMR_SLC_7	MUTE_SMR_SLC_6	MUTE_SMR_SLC_5	MUTE_SMR_SLC_4	MUTE_SMR_SLC_3	MUTE_SMR_SLC_2	MUTE_SMR_SLC_1	MUTE_SMR_SLC_0

MSB								LSB	Function
D7	D6	D5	D4	D3	D2	D1	D0		
0	0	0	0	0	0	0	0	FM limiting sensitivity adjustment 2 Adjusting the threshold value (second start point: Mute voltage slope x 2) at which noise convergence is to be achieved. 0: Threshold value Low (weak electric field)	
0	0	0	0	0	0	0	1	↓	
1	1	1	1	1	1	1	0		
1	1	1	1	1	1	1	1	255: Threshold value High (strong electric field)	

SA36. FM Limiting Sensitivity Adjustment 1

D7	D6	D5	D4	D3	D2	D1	D0
MUTE_SMR_ZERO_7	MUTE_SMR_ZERO_6	MUTE_SMR_ZERO_5	MUTE_SMR_ZERO_4	MUTE_SMR_ZERO_3	MUTE_SMR_ZERO_2	MUTE_SMR_ZERO_1	MUTE_SMR_ZERO_0

MSB								LSB	Function
D7	D6	D5	D4	D3	D2	D1	D0		
0	0	0	0	0	0	0	0	FM limiting sensitivity adjustment 1 Adjusting the threshold value (first start point: Mute voltage slope x 1) at which -3 dB sensitivity adjustment is to be performed. 0: Threshold value Low (weak electric field)	
0	0	0	0	0	0	0	1	↓	
1	1	1	1	1	1	1	0		
1	1	1	1	1	1	1	1	255: Threshold value High (strong electric field)	

SA37. Modulation Index Detection Sensitivity (+ Side)

D7	D6	D5	D4	D3	D2	D1	D0
BPF_MOD_MAX_7	BPF_MOD_MAX_6	BPF_MOD_MAX_5	BPF_MOD_MAX_4	BPF_MOD_MAX_3	BPF_MOD_MAX_2	BPF_MOD_MAX_1	BPF_MOD_MAX_0

MSB								LSB	Function
D7	D6	D5	D4	D3	D2	D1	D0		
0	0	0	0	0	0	0	0	IF filter modulation index detection threshold value [+ side] = Low * Provide hysteresis with respect to the Narrow/SA38 settings if the threshold value is exceeded.	
0	0	0	0	0	0	0	1	↓	
1	1	1	1	1	1	1	0		
1	1	1	1	1	1	1	1	IF filter modulation index detection threshold value [+ side] = High * Provide hysteresis with respect to the Narrow/SA38 settings if the threshold value is exceeded.	

LV25700PM

SA38. Modulation Index Detection Sensitivity (- Side)

D7	D6	D5	D4	D3	D2	D1	D0
BPF_MOD_MIN_7	BPF_MOD_MIN_6	BPF_MOD_MIN_5	BPF_MOD_MIN_4	BPF_MOD_MIN_3	BPF_MOD_MIN_2	BPF_MOD_MIN_1	BPF_MOD_MIN_0

MSB							LSB	Function
D7	D6	D5	D4	D3	D2	D1	D0	
0	0	0	0	0	0	0	0	IF filter modulation index detection threshold value [- side] = Low * Provide hysteresis with respect to the Narrow/SA37 settings if the threshold value is exceeded.
0	0	0	0	0	0	0	1	↓
1	1	1	1	1	1	1	0	
1	1	1	1	1	1	1	1	IF filter modulation index detection threshold value [- side] = High * Provide hysteresis with respect to the Narrow/SA37 settings if the threshold value is exceeded.

SA39. Modulation Index Detection Operation Start Point (+ side)

D7	D6	D5	D4	D3	D2	D1	D0
BPF_SMR_MAX_7	BPF_SMR_MAX_6	BPF_SMR_MAX_5	BPF_SMR_MAX_4	BPF_SMR_MAX_3	BPF_SMR_MAX_2	BPF_SMR_MAX_1	BPF_SMR_MAX_0

MSB							LSB	Function
D7	D6	D5	D4	D3	D2	D1	D0	
0	0	0	0	0	0	0	0	IF filter modulation index detection function OFF threshold value [+ side] = Low Turns off the modulation detection function above a certain electric field strength (compared with S-meter value) or stronger. * Provide hysteresis with respect to the SA40 settings.
0	0	0	0	0	0	0	1	↓
1	1	1	1	1	1	1	0	
1	1	1	1	1	1	1	1	IF filter modulation index detection function OFF threshold value [+ side] = High

SA40. Modulation Index Detection Operation Start Point (- side)

D7	D6	D5	D4	D3	D2	D1	D0
BPF_SMR_MIN_7	BPF_SMR_MIN_6	BPF_SMR_MIN_5	BPF_SMR_MIN_4	BPF_SMR_MIN_3	BPF_SMR_MIN_2	BPF_SMR_MIN_1	BPF_SMR_MIN_0

MSB							LSB	Function
D7	D6	D5	D4	D3	D2	D1	D0	
0	0	0	0	0	0	0	0	IF filter modulation index detection function OFF threshold value [- side] = Low Turns off the modulation detection function above a certain electric field strength (compared with S-meter value) or stronger. * Provide hysteresis with respect to the SA39 settings.
0	0	0	0	0	0	0	1	↓
1	1	1	1	1	1	1	0	
1	1	1	1	1	1	1	1	IF filter modulation index detection function OFF threshold value [- side] = High

LV25700PM

SA41. IF Filter Band Limitation

D7	D6	D5	D4	D3	D2	D1	D0
BPF_LIMIT_7	BPF_LIMIT_6	BPF_LIMIT_5	BPF_LIMIT_4	BPF_LIMIT_3	BPF_LIMIT_2	BPF_LIMIT_1	BPF_LIMIT_0

MSB								LSB	Function
D7	D6	D5	D4	D3	D2	D1	D0		
0	0	0	0	0	0	0	0	Limits the narrow band of the IF filter. [Wide band is as is = 180kHz.] 0: 180kHz (narrow band 180kHz = No band control)	
0	0	0	0	0	0	0	1	↓	
1	1	1	1	1	1	1	0		
1	1	1	1	1	1	1	1	255:40kHz	

SA42. IF Filter band Fixing

D7	D6	D5	D4	D3	D2	D1	D0
BPF_FIX_7	BPF_FIX_6	BPF_FIX_5	BPF_FIX_4	BPF_FIX_3	BPF_FIX_2	BPF_FIX_1	BPF_FIX_0

MSB								LSB	Function
D7	D6	D5	D4	D3	D2	D1	D0		
0	0	0	0	0	0	0	0	Fixes the band of the IF filter. [Enabled when SA43 D7 = 1] 0: 180kHz (forced wide band)	
0	0	0	0	0	0	0	1	↓	
1	1	1	1	1	1	1	0		
1	1	1	1	1	1	1	1	255: 40kHz (forced narrow band)	

SA43. IF Filter Time Constant/Detection Sensitivity

D7	D6	D5	D4	D3	D2	D1	D0
BPF_FIX	BPF_TC_2	BPF_TC_1	BPF_TC_0	-	-	BPF_SLOPE_1	BPF_SLOPE_0

MSB								LSB	Function
D7	D6	D5	D4	D3	D2	D1	D0		
						0	0	Adjusts the sensitivity of the IF filter (coarse adjustment). × 0.5: Detection sensitivity low	
						0	1	× 1.0:	
						1	0	× 2: Detection sensitivity high	
				0	0			Not used. Fixed at 0.	
	0	0	0					IF Filter sampling time = 2.19 ms	
	0	0	1					IF Filter sampling time = 8.78ms	
	0	1	0					IF Filter sampling time = 17.56ms	
	0	1	1					IF Filter sampling time = 35.12ms	
0								IF Filter band forced mode switch 0: IF Filter band auto mode (normal)	
1								1: IF Filter band forced mode [SA42 settings enabled]	

LV25700PM

SA44. IF Band Variable AFC Control (+ Side)

D7	D6	D5	D4	D3	D2	D1	D0
AFC_MAX_7	AFC_MAX_6	AFC_MAX_5	AFC_MAX_4	AFC_MAX_3	AFC_MAX_2	AFC_MAX_1	AFC_MAX_0

MSB								LSB	Function
D7	D6	D5	D4	D3	D2	D1	D0		
0	0	0	0	0	0	0	0	IF Filter AFC control threshold value [+ side] = 0: Threshold value Low (sensitive to interference Δf small) * Provide hysteresis with respect to the SA45 settings.	
0	0	0	0	0	0	0	1		
								↓	
1	1	1	1	1	1	1	0		
1	1	1	1	1	1	1	1	IF Filter AFC control threshold value [+ side] = 255: Threshold value High (sensitive to interference Δf large)	

SA45. IF Band Variable AFC Control (- Side)

D7	D6	D5	D4	D3	D2	D1	D0
AFC_MIN_7	AFC_MIN_6	AFC_MIN_5	AFC_MIN_4	AFC_MIN_3	AFC_MIN_2	AFC_MIN_1	AFC_MIN_0

MSB								LSB	Function
D7	D6	D5	D4	D3	D2	D1	D0		
0	0	0	0	0	0	0	0	IF Filter AFC control threshold value [- side] = 0: Threshold value Low (sensitive to interference Δf small) * Provide hysteresis with respect to the SA44 settings.	
0	0	0	0	0	0	0	1		
								↓	
1	1	1	1	1	1	1	0		
1	1	1	1	1	1	1	1	IF Filter AFC control threshold value [- side] = 255: Threshold value high (sensitive to interference Δf large)	

SA46. Reserved

D7	D6	D5	D4	D3	D2	D1	D0
-	-	-	-	-	-	-	-

MSB								LSB	Function
D7	D6	D5	D4	D3	D2	D1	D0		
								System reserved area	

LV25700PM

SA47. HCC Cut-off Frequency/Automatic Interpolation Setting/Others

D7	D6	D5	D4	D3	D2	D1	D0
RDS_AFC	INT_ATT_ON	HCC_SW3	HCC_SW2	HCC_SW1	-	-	-

MSB								LSB	Function
D7	D6	D5	D4	D3	D2	D1	D0		
					0	0	0	Not used. Fixed at 0.	
		0	0	0				HCC cut-ff adjustment: fc = 400Hz (when C51 = 2200pF)	
		0	0	1				HCC cut-ff adjustment: fc = 500Hz (when C51 = 2200pF)	
		0	1	0				HCC cut-ff adjustment: fc = 600Hz (when C51 = 2200pF)	
		0	1	1				HCC cut-ff adjustment: fc = 800Hz (when C51 = 2200pF) * Recommended for AM	
		1	0	0				HCC cut-ff adjustment: fc = 1kHz (when C51 = 2200pF)	
		1	0	1				HCC cut-ff adjustment: fc = 1.4kHz (when C51 = 2200pF)	
		1	1	0				HCC cut-ff adjustment: fc = 2.2kHz (when C51 = 2200pF) * Recommended for FM	
		1	1	1				HCC cut-ff adjustment: fc = 5.5kHz (when C51 = 2200pF)	
	0							Not used. Fixed at 0.	
0								AF search time constant switching: AF search mode	
1								AF search time constant switching: Receive/at SEEK	

SA48. DAC Interpolation Selection

D7	D6	D5	D4	D3	D2	D1	D0
-	-	-	-	-	S_METER INT_P	RF_INT_P	IRR_INT_P

MSB								LSB	Function
D7	D6	D5	D4	D3	D2	D1	D0		
							0	IRR-ADJ automatic interpolation disabled (no interpolation by internal firmware)	
							1	IRR ADJ automatic interpolation enabled	
						0		RF-DAC automatic interpolation disabled (no interpolation by internal firmware)	
						1		RF-DAC automatic interpolation enabled	
					0			S_METER_SHIFT automatic interpolation disabled (no interpolation by internal firmware)	
					1			S_METER_SHIFT automatic interpolation enabled	
0	0	0	0	0				System reserved area	

SA49. Reserved

D7	D6	D5	D4	D3	D2	D1	D0
-	-	-	-	-	-	-	-

MSB								LSB	Function
D7	D6	D5	D4	D3	D2	D1	D0		
								System reserved area	

LV25700PM

SA50. RDS Signal Quality Sensitivity Setting

D7	D6	D5	D4	D3	D2	D1	D0
RDS_QO_UDET_7	RDS_QO_UDET_6	RDS_QO_UDET_5	RDS_QO_UDET_4	RDS_QO_UDET_3	RDS_QO_UDET_2	RDS_QO_UDET_1	RDS_QO_UDET_0

MSB								LSB	Function
D7	D6	D5	D4	D3	D2	D1	D0		
0	0	0	0	0	0	0	0	Signal Quality sense = High (threshold value low)	
0	0	0	0	0	0	0	1		
								↓	
1	1	1	1	1	1	1	0		
1	1	1	1	1	1	1	1	Signal Quality sense = Low (threshold value high)	

SA51 to 58. FM RF 8-bit DAC Point Values

D7	D6	D5	D4	D3	D2	D1	D0
RF_DAC_POINT_7	RF_DAC_POINT_6	RF_DAC_POINT_5	RF_DAC_POINT_4	RF_DAC_POINT_3	RF_DAC_POINT_2	RF_DAC_POINT_1	RF_DAC_POINT_0

MSB								LSB	Function
D7	D6	D5	D4	D3	D2	D1	D0		
0	0	0	0	0	0	0	0	RF DAC = 0.3V (min)	
0	0	0	0	0	0	0	1		
								↓	
1	1	1	1	1	1	1	0		
1	1	1	1	1	1	1	1	RF DAC = 7.1V (max)	

SA59 to 66. FM ANT 8-bit DAC Point Values (IRR_POINT)

D7	D6	D5	D4	D3	D2	D1	D0
ANT_DAC_POINT_7	ANT_DAC_POINT_6	ANT_DAC_POINT_5	ANT_DAC_POINT_4	ANT_DAC_POINT_3	ANT_DAC_POINT_2	ANT_DAC_POINT_1	ANT_DAC_POINT_0

MSB								LSB	Function
D7	D6	D5	D4	D3	D2	D1	D0		
0	0	0	0	0	0	0	0	ANT DAC = 0.3V (min)	
0	0	0	0	0	0	0	1		
								↓	
1	1	1	1	1	1	1	0		
1	1	1	1	1	1	1	1	ANT DAC = 7.1V (max)	

SA67 to 74. Signal meter Point Values

D7	D6	D5	D4	D3	D2	D1	D0
-	-	-	S_METER4	S_METER3	S_METER2	S_METER1	S_METER0

MSB								LSB	Function
D7	D6	D5	D4	D3	D2	D1	D0		
			0	0	0	0	0	FM Vsm (30dBμ) = 2.293V	
			0	0	0	0	1	FM Vsm (30dBμ) = 2.239V	
								↓	
			1	1	1	1	0	FM Vsm (30dBμ) = 1.456V	
			1	1	1	1	1	FM Vsm (30dBμ) = 1.427V	
0	0	0						Not used. Fixed at 0.	

LV25700PM

The point frequencies are fixed as shown in the table below. The place of destination is selected using the area code [SA94 D7-D4] and Align number [SA94 D3-D0].

Area	JAPAN	USA		USA + Weather		Europe		Europe + OIRT	
Area code [SA94 D7-D4]	0000	0001		0100		0010		0011	
Align number [SA94 D3-D0]	0011	0011	0101	0011	0101	0011	0101	0011	0101
Point0	76	87.9	87.9	87.9	87.9	87.5	87.5	65	65
Point1	83	98.1	90.1	98.1	90.1	98	90	70	70
Point2	90	108.1	98.1	108.1	98.1	108	98	74	74
Point3			106.1	162.4	106.1		106	87.5	87.5
Point4			108.1	162.55	108.1		108	98	90
Point5					162.4			108	98
Point6					162.55				106
Point7									108

SA75 to 79, SA83 to 92. Reserved

D7	D6	D5	D4	D3	D2	D1	D0
-	-	-	-	-	-	-	-

MSB								LSB	Function
D7	D6	D5	D4	D3	D2	D1	D0		
									System reserved area

SA80. AF Search PLL N Value Higher-order 8 Bits

D7	D6	D5	D4	D3	D2	D1	D0
AF_P15	AF_P14	AF_P13	AF_P12	AF_P11	AF_P10	AF_P9	AF_P8

MSB								LSB	Function
D7	D6	D5	D4	D3	D2	D1	D0		
0	0	0	0	0	0	0	0		
0	0	0	0	0	0	0	1		
0	0	0	0	0	0	1	0		
-	-	-	-	-	-	-	-		
1	1	1	1	1	1	0	0		
1	1	1	1	1	1	0	1		
1	1	1	1	1	1	1	0		
1	1	1	1	1	1	1	1		

LV25700PM

SA81. AF Search PLL N Value Lower-order 8 Bits

D7	D6	D5	D4	D3	D2	D1	D0
AF_P7	AF_P6	AF_P5	AF_P4	AF_P3	AF_P2	AF_P1	AF_P0

MSB								LSB	Function
D7	D6	D5	D4	D3	D2	D1	D0		
0	0	0	0	0	0	0	0		
0	0	0	0	0	0	0	1		
0	0	0	0	0	0	1	0		
-	-	-	-	-	-	-	-		
1	1	1	1	1	1	0	0		
1	1	1	1	1	1	0	1		
1	1	1	1	1	1	1	0		
1	1	1	1	1	1	1	1		

* SA1: D7 to D0 [P7 to P0] = ALL High

SA82. AF Search RF 8-bit DAC

D7	D6	D5	D4	D3	D2	D1	D0
AF_RFD7	AF_RFD6	AF_RFD5	AF_RFD4	AF_RFD3	AF_RFD2	AF_RFD1	AF_RFD0

MSB								LSB	Function
D7	D6	D5	D4	D3	D2	D1	D0		
0	0	0	0	0	0	0	0	RF DAC = 0.3V (min)	
0	0	0	0	0	0	0	1		
								↓	
1	1	1	1	1	1	1	0		
1	1	1	1	1	1	1	1	RF DAC = 7.1V (max)	

SA83. AF Search ANT 8-bit DAC (Not used when used as IRR_ADJ)

D7	D6	D5	D4	D3	D2	D1	D0
AF_ANTD7	AF_ANTD6	AF_ANTD5	AF_ANTD4	AF_ANTD3	AF_ANTD2	AF_ANTD1	AF_ANTD0

MSB								LSB	Function
D7	D6	D5	D4	D3	D2	D1	D0		
0	0	0	0	0	0	0	0	ANT DAC = 0.3V (min)	
0	0	0	0	0	0	0	1		
								↓	
1	1	1	1	1	1	1	0		
1	1	1	1	1	1	1	1	ANT DAC = 7.1V (max)	

LV25700PM

SA93. Custom Code

D7	D6	D5	D4	D3	D2	D1	D0
CUSTOM_CODE_7	CUSTOM_CODE_6	CUSTOM_CODE_5	CUSTOM_CODE_4	CUSTOM_CODE_3	CUSTOM_CODE_2	CUSTOM_CODE_1	CUSTOM_CODE_0

* Used to store information about anything other than the place of destination

SA94. Place of Destination Selection

D7	D6	D5	D4	D3	D2	D1	D0
AREA_CODE_3	AREA_CODE_2	AREA_CODE_1	AREA_CODE_0	ALIGN_NO_3	ALIGN_NO_2	ALIGN_NO_1	ALIGN_NO_0

MSB								LSB	Function
D7	D6	D5	D4	D3	D2	D1	D0		
				0	0	1	1	POINT Data count 3 (See the above POINT Frequency Chart for details.)	
				0	1	0	1	POINT Data count 5 (See the above POINT Frequency Chart for details.)	
0	0	0	0					For Japan	
0	0	0	1					For USA and Canada	
0	0	1	0					For Europe	
0	0	1	1					For Europe and OIRT	
0	1	0	0					For USA, Canada plus Weather band	

SA95. Checksum

D7	D6	D5	D4	D3	D2	D1	D0
CHECK_SUM_7	CHECK_SUM_6	CHECK_SUM_5	CHECK_SUM_4	CHECK_SUM_3	CHECK_SUM_2	CHECK_SUM_1	CHECK_SUM_0

MSB								LSB	Function
D7	D6	D5	D4	D3	D2	D1	D0		
								Checksum area	

LV25700PM

Special Commands

SA 248. Flash Write Mode Set (3 Bytes)

DATA2	DATA1	DATA0
ID2	ID1	ID0

This sets the flash memory write mode. Set arbitrary values other than 000000H or FFFFFFFH in the 3 ID bytes. This command sets the flash memory to write mode. Actual write to the flash memory is performed by transmitting SA252 within 150ms after transmitting this command, and then executing write.

SA 249. RDS Mute ON

This mute command (DET OUT attenuation factor = 40dB) is used for AF search and other operations in RDS mode.
* This command consists of only a slave address and sub address, and there is no data.

SA 250. RDS Mute OFF

This command is used to set the above-noted RDS mute to OFF. RDS mute is automatically set to OFF during reset, when switching the SA04 FM/AM bit, and when executing SA252 Flash Write.
* This command consists of only a slave address and sub address, and there is no data.

SA 251. Flash Default

This command reads the SA01 to SA95 data for the current band (FM or AM) from the LV25700 internal flash memory. It is used to discard the adjustment data, or when performing verification after executing flash write by SA252.

During reset the LV25700 automatically reads the FM data from the flash memory. In addition, when switching the band, the LV25700 also automatically reads the FM data from the flash memory, so execution of this command is not necessary in these cases.

* This command consists of only a slave address and sub address, and there is no data.

SA 252. Flash Write (3 Bytes)

DATA2	DATA1	DATA0
ID2	ID1	ID0

This command writes the SA01 to SA95 data in the flash memory. This command is used as a set together with SA248 to prevent write errors. When this command is transmitted within 150ms after transmitting SA248 and the IDs match, the SA01 to SA95 setting values for the current band (FM or AM) are written in the LV25700 internal flash memory. This command should be executed after all the adjustment data is set and the SA95 checksum data is transmitted.

Note that the FM and AM setting values are written in separate areas of the flash memory.
Set the inverse value of the ID transmitted by SA248 in the 3 ID bytes.

SA 253. Switching the Normal Frequency

This command switches the frequency and RF DAC value switched by SA254 to the normal (designated by SA1, SA2 and SA5) frequency and RF DAC value.

* This command consists of only a slave address and sub address, and there is no data.

SA 254. Switching the AF Frequency

This command switches to the frequency and RF DAC value designated by SA80, SA81 and SA82.

* This command consists of only a slave address and sub address, and there is no data.

LV25700PM

SA 255. Firmware Information

After this command is sent, the LV25700 enters the firmware information send wait status.
 The firmware information can be read by reading 8 bytes.
 For further details, refer to IIC-DATA-OUTPUT (FIRMWARE INFORMATION).
 * This command consists of only a slave address and sub address, and there is no data.

I²C-DATA-OUTPUT

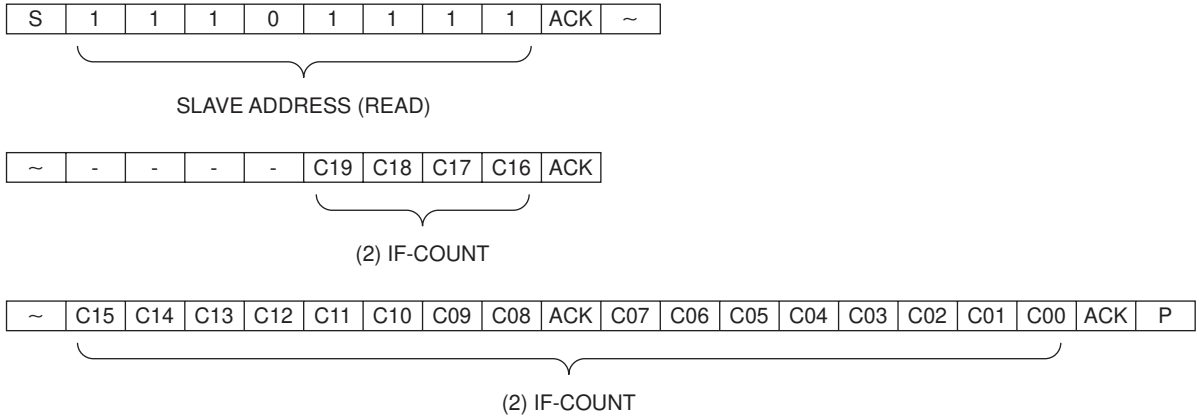

Number	Description
(1)	Calls the data inside the IC. Current SD only
(2)	Data obtained by latching the contents of the IF count counter (20-bit binary counter). C19: Binary counter MSB C0: Binary counter LSB

I²C-DATA-OUTPUT (SA DATA OUTPUT)

This is used to notify the host microcontroller of the LV25700 sub address setting information.
 Set the slave address (write), and load the sub address (01 to 95) with the information to be acquired with D7 set to 1.
 Next set the slave address (read) and read 8 bytes (fixed to 8 bytes).
 8 bytes of sub address information can be read starting from the sub address n designated by the slave address (write) to n + 7. 95 (0x5F) and subsequent data are unpredictable.

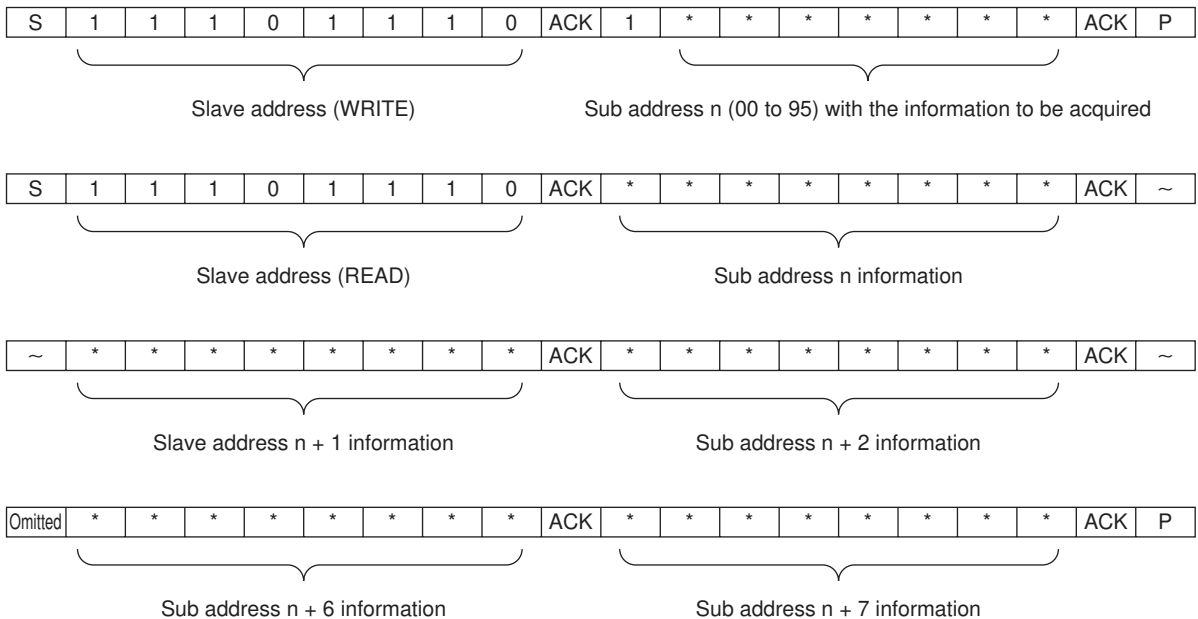

LV25700PM

I²C-DATA-OUTPUT (FIRMWARE INFORMATION)

This is used to notify the host microcontroller of the LV25700 firmware information.

Designate 0xff as the sub address to be acquired, and get 8 bytes of data with SA DATA OUT as follows (fixed to 8 bytes).

Data other than each firmware information is undetermined.

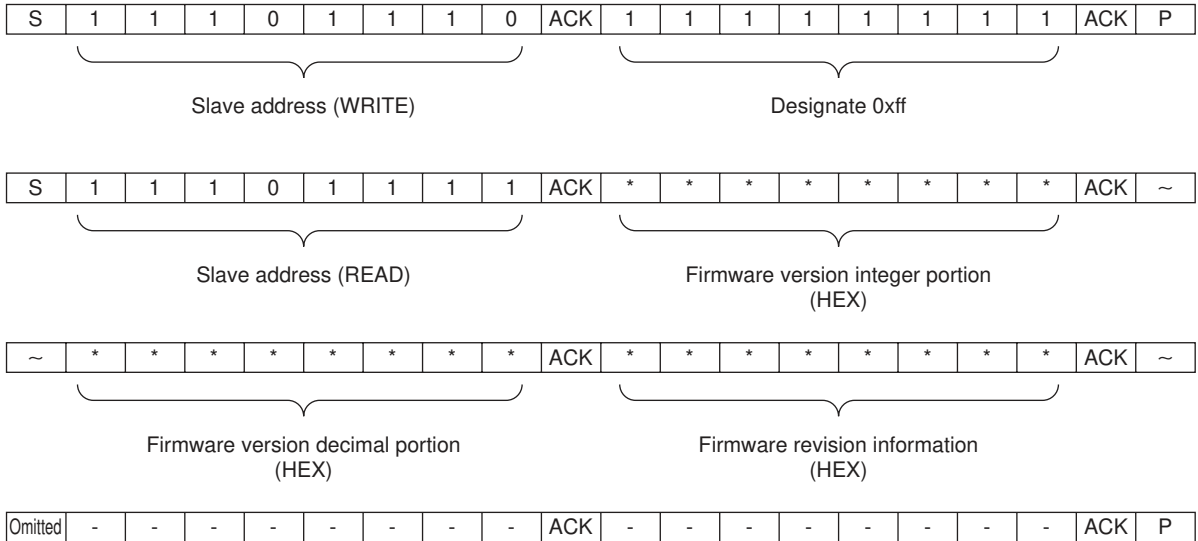

- SANYO Semiconductor Co.,Ltd. assumes no responsibility for equipment failures that result from using products at values that exceed, even momentarily, rated values (such as maximum ratings, operating condition ranges, or other parameters) listed in products specifications of any and all SANYO Semiconductor Co.,Ltd. products described or contained herein.
- SANYO Semiconductor Co.,Ltd. strives to supply high-quality high-reliability products, however, any and all semiconductor products fail or malfunction with some probability. It is possible that these probabilistic failures or malfunction could give rise to accidents or events that could endanger human lives, trouble that could give rise to smoke or fire, or accidents that could cause damage to other property. When designing equipment, adopt safety measures so that these kinds of accidents or events cannot occur. Such measures include but are not limited to protective circuits and error prevention circuits for safe design, redundant design, and structural design.
- In the event that any or all SANYO Semiconductor Co.,Ltd. products described or contained herein are controlled under any of applicable local export control laws and regulations, such products may require the export license from the authorities concerned in accordance with the above law.
- No part of this publication may be reproduced or transmitted in any form or by any means, electronic or mechanical, including photocopying and recording, or any information storage or retrieval system, or otherwise, without the prior written consent of SANYO Semiconductor Co.,Ltd.
- Any and all information described or contained herein are subject to change without notice due to product/technology improvement, etc. When designing equipment, refer to the "Delivery Specification" for the SANYO Semiconductor Co.,Ltd. product that you intend to use.
- Information (including circuit diagrams and circuit parameters) herein is for example only; it is not guaranteed for volume production.
- Upon using the technical information or products described herein, neither warranty nor license shall be granted with regard to intellectual property rights or any other rights of SANYO Semiconductor Co.,Ltd. or any third party. SANYO Semiconductor Co.,Ltd. shall not be liable for any claim or suits with regard to a third party's intellectual property rights which has resulted from the use of the technical information and products mentioned above.

This catalog provides information as of June, 2010. Specifications and information herein are subject to change without notice.