

PANDUIT PART #	WIRE RANGE (ACCEPTS 2 WIRES)		COLOR (DIN)	WIRE STRIP LENGTH +1/32 -0 [+0,8 -0]	MAX. WIRE INSUL. DIA.	WIRE CLASS	DIMENSIONS in. [mm]						MANUAL TOOLS/DIES	AUTOMATIC TOOLS/DIES
	AWG 2X	[mm ²] 2X					L	P	ID	OD (REF.)	B (REF.)	T		
*FTD75-8	22-20	[0,5]	WHITE	7/16 [11,2]	.09 [2,4]	B, K, M	.59 [15,0]	.31 [8,0]	.06 [1,5]	.07 [1,8]	.18 [4,6]	CT-1002 CT-1003 CT-1090 ^^CD-090 CT-1123 CT-1160 CT-1170 #CT-2523CH	CTFP-25, CTFP-40	
FTD76-8	18	[0,75]	GREY	7/16 [11,2]	.09 [2,4]	B, K, M	.59 [15,0]	.31 [8,0]	.07 [1,8]	.08 [2,1]	.20 [5,0]			
FTD76-10	18	[0,75]	GREY	9/16 [14,0]	.09 [2,4]	B, K, M	.67 [17,0]	.39 [10,0]	.07 [1,8]	.08 [2,1]	.20 [5,0]			
FTD77-8	18	[1,0]	RED	7/16 [11,2]	.11 [2,8]	B, K, M	.59 [15,0]	.31 [8,0]	.08 [2,0]	.09 [2,35]	.20 [5,0]			
FTD77-10	18	[1,0]	RED	9/16 [14,0]	.11 [2,8]	B, K, M	.67 [17,0]	.39 [10,0]	.08 [2,0]	.09 [2,35]	.20 [5,0]			
FTD78-8	16	[1,5]	BLACK	7/16 [11,2]	.12 [3,0]	B, K, M	.63 [16,0]	.31 [8,0]	.09 [2,3]	.10 [2,6]	.25 [6,4]			
FTD78-12	16	[1,5]	BLACK	21/32 [16,8]	.12 [3,0]	B, K, M	.79 [20,0]	.47 [12,0]	.09 [2,3]	.10 [2,6]	.25 [6,4]			
FTD80-10	14	[2,5]	BLUE	9/16 [14,0]	.15 [3,8]	K, M	.73 [18,5]	.39 [10,0]	.11 [2,8]	.13 [3,3]	.30 [7,6]			
FTD80-13	14	[2,5]	BLUE	23/32 [18,2]	.15 [3,8]	K, M	.85 [21,5]	.51 [13,0]	.11 [2,8]	.13 [3,3]	.30 [7,6]			
FTD81-12	12	[4,0]	GREY	21/32 [16,8]	.17 [4,3]	G, K, M	.91 [23,0]	.47 [12,0]	.15 [3,8]	.17 [4,2]	.34 [8,6]			CT-1002, +CT-1003, CT-1090, ^^CD-090, CT-1123, CT-1160, CT-1170, #CT-2523CH
FTD82-14	10	[6,0]	YELLOW	3/4 [19,0]	.19 [4,8]	G, I, K, M	.98 [25,0]	.55 [14,0]	.19 [4,9]	.21 [5,3]	.38 [9,7]	+CT-1003, CT-1004, CT-1090, ^^CD-090, CT-1104, ^CT-1160, ^CT-1170, #CT-2504CH	----	
FTD83-14	8	[10,0]	RED	3/4 [19,0]	.28 [7,1]	G, H, I, K, M	1.02 [26,0]	.55 [14,0]	.26 [6,5]	.27 [6,9]	.50 [12,7]	CT-1005	----	
FTD84-16	6	[16,0]	BLUE	13/16 [21,0]	.35 [8,9]	G, H, I, K, M	1.22 [31,0]	.63 [16,0]	.33 [8,5]	.35 [8,9]	.65 [16,5]			

* UL LISTED WITH 20 AWG ONLY, UL486F SCOPE IS 20 - 1/0 AWG. WHITE IS DIN COLOR FOR 20 AWG [0,5]
 + TOOL/PART COMBINATION IS NOT UL LISTED
 ^ TOOL/PART COMBINATION IS UL LISTED WITH CLASS M ONLY
 ^^ DIES USED WITH CT-2300 TOOL
 # CRIMP HEAD USED WITH CT-2500 TOOL

NOTES:

- USED FOR:
 - UL LISTED WITH STRANDED COPPER WIRE ONLY
 - 221°F [105°C] MAX. OPERATING TEMPERATURE
- MATERIAL:
 - STAMPING: COPPER, TIN PLATED
 - HOUSING: POLYPROPYLENE, COLOR CODED
 - COLOR CODE CONFORMS TO DIN STANDARD
- SEE www.panduit.com FOR PACKAGE QUANTITIES
- DIMENSIONS IN BRACKETS ARE METRIC EQUIVALENT
- DIMENSIONAL PART TOLERANCE +/-0.016 [0,4]

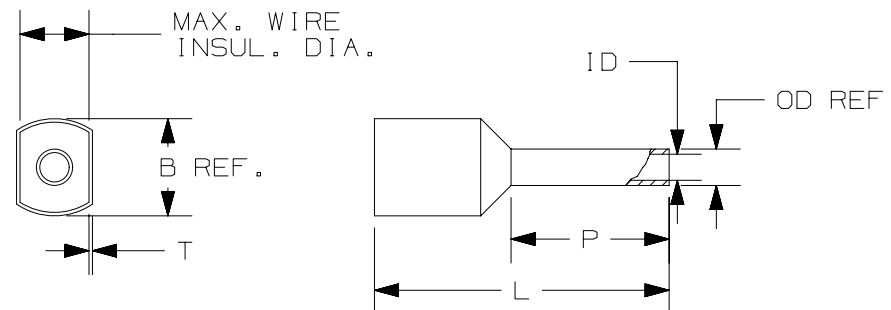

REV	DATE	BY	CHK	APR	DESCRIPTION	ECN
20	11-01-2018	FCHE	TMR	JADE	ADDED TOOL CTFP-25, CTFP-40, CTFP-100 TO AUTOMATIC COLUMN	041964
19	3.29.17	TMR	TMR	RGB	ADDED TOOL INFORMATION RELATED TO CT-2500 TOOL	A41669
18	11.9.16	JHNU	JLOV	RGB	ADDED CT-1090, CT-2300, CT-1160, CT-1170 REVISED DRAWING SIZE: B SIZE WAS A SIZE	A41669

TITLE FERRULES WITH SLEEVES TWIN WIRE (DIN) FTD: 2 WIRES INSERTED INTO FERRULE	
CUSTOMER DRAWING	
ITEM REVISION NAME N41669BA/20	PANDUIT
DATASET FILE NAME N41669BA_DC/20	
UNLESS OTHERWISE SPECIFIED, DIMENSIONAL TOLERANCES ARE: IN [mm] .x ± .1 [2,54] .xxx ± .005 [.127] .xx ± .01 [.25] ANGLES ± 5°	
DRAWING NUMBER: A41669	
DRAWN BY JKD	DATE -
CHK -	SCALE N.T.S.
SHT 1 OF 1	
SIZE B	

D10100DB/17