

AMR2302

High Accuracy, Low Noise Dual Axis Linear Magnetic Sensor

Description

The AMR2302 linear sensor utilizes two push-pull Wheatstone bridges each composed of four highly sensitive AMR sensor elements. These Wheatstone bridges effectively compensate the sensor's temperature drift to achieve outstanding temperature stability with minimal noise. AMR2302 is available in the SOP16 package.

Features and Benefits

- Anisotropic magnetoresistance (AMR) technology
- Low noise density: 300 pT/ $\sqrt{\text{Hz}}$ @1 Hz
- Wide range supply voltages
- Low saturation field
- Excellent temperature stability
- Low hysteresis

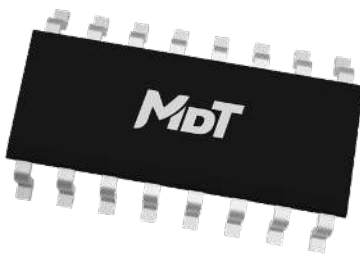

SOP16

Applications

- Weak magnetic field sensing
- Current sensor
- Position sensor
- Magnetometer

Selection Guide

Part Number	Linear Range	Sensitivity	Set/reset Coil Resistance	Offset Coil Resistance	Noise Density	Package	Packing Form
AMR2302P	± 3 Gs	0.9 mV/V/Gs	5 Ω	45 Ω	300 pT/ $\sqrt{\text{Hz}}$	SOP16	Tape & Reel

Catalogue

1. Functional Block Diagram.....	03
2. Sensing Direction	03
3. Pin Configuration	03
4. Absolute Maximum Ratings	04
5. Electrical Specifications.....	04
6. Typical Output Characteristics.....	05
7. Application Information	06
8. Dimensions.....	07

1. Functional Block Diagram

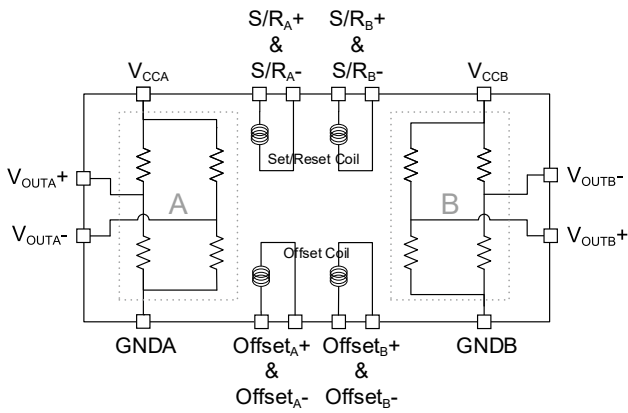

Figure 1. Block Diagram

2. Sensing Direction

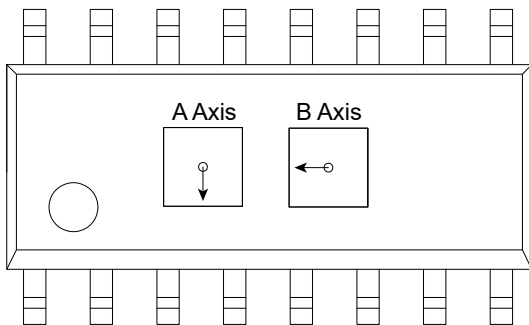

Figure 2. Sensing Direction (SOP16)

3. Pin Configuration

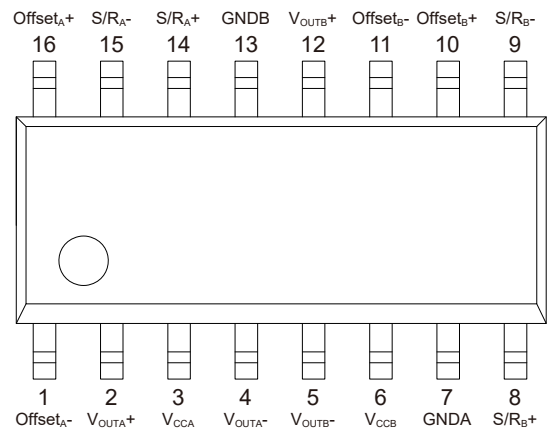

Figure 3. Pin Configuration (SOP16)

Pin Number	Name	Function
1	Offset _{A-}	A axis offset voltage -
2	V _{OUTA+}	A axis output +
3	V _{CCA}	A axis supply voltage
4	V _{OUTA-}	A axis output -
5	V _{OUTB-}	B axis output -
6	V _{CCB}	B axis supply voltage
7	G_NDA	A axis ground
8	S/R _{B+}	B axis set/reset input+
9	S/R _{B-}	B axis set/reset input -
10	Offset _{B+}	B axis offset voltage +
11	Offset _{B-}	B axis offset voltage -
12	V _{OUTB+}	B axis output +
13	G_NDB	B axis ground
14	S/R _{A+}	A axis set/reset input +
15	S/R _{A-}	A axis set/reset input -
16	Offset _{A+}	A axis offset +

4. Absolute Maximum Ratings

Parameters	Symbol	Min.	Max.	Unit
Supply Voltage	V_{CC}	-	12	V
ESD Performance (HBM)	V_{ESD}	-	4	kV
Operating Ambient Temperature	T_A	-55	150	°C
Storage Ambient Temperature	T_{STG}	-55	175	°C
Soldering Temperature	T_i	-	260	°C
Magnetic Field	B	-	10000	Gs

5. Electrical Specifications

$V_{CC} = 5.0$ V, $T_A = 25$ °C, $I_{S/R} = 1.5$ A, dual differential output unless otherwise specified

Parameter	Symbol	Condition	Min.	Typ.	Max.	Unit
Supply Voltage	V_{CC}	Bridge voltage, referenced to ground	1.8	5	12	V
Bridge Resistance	R_B	$I = 5$ mA	600	650	1100	Ω
Field Range	B_{SAT}	Full scale (FS)	-6	-	6	Gs
Linearity Error	NONL	Fit in: ± 1 Gs	-	0.05	-	%FS
		Fit in: ± 3 Gs	-	0.15	-	
		Fit in: ± 6 Gs	-	1.0	1.6	
Hysteresis Error	HYS	2 sweeps, across ± 6 Gs	-	0.05	-	%FS
Repeatability Error	B_{repeat}	2 sweeps, across ± 6 Gs	-	0.08	-	%FS
Bridge Offset	V_{OFFSET}	$V_{OFFSET} = (V_{OUT+}) - (V_{OUT-})$, B = 0 Gs, after set pulse	-10	± 2	+10	mV/V
Sensitivity	SEN	-	0.6	0.9	1.1	mV/V/Gs
Voltage Noise Density	V_{noise}	At 1 Hz	-	25	-	nV/ \sqrt{Hz}
Magnetic Noise Density	B_{noise}	At 1 Hz	-	300	-	pT/ \sqrt{Hz}
Resolution	RES	Bandwidth = 10 Hz	-	40	-	μ Gs
Bandwidth	BW	Magnetic signal (lower limit = DC)	-	5	-	MHz
Offset Coil Resistance	$R_{OFFCOIL}$	Measured from OFFSET+ to OFFSET-	35	45	55	Ω
Offset Field	$B_{OFFCOIL}$	Field applied in sensitive direction	4.0	5.0	7.0	mA/Gs
Set/Reset Coil Resistance	$R_{S/R}$	Measured between S/R+ and S/R-	3	5	7	Ω
Set/Reset Current	$I_{S/R}$	2 μ s current pulse	1	1.5	5	A
Disturbing Field	$B_{disturb}$	Sensitivity starts to degrade, restore by S/R pulse	-	20	-	Gs
Sensitivity Temperature Coefficient	TCS	$T_A = -40$ °C to 125 °C	-	-3800	-	PPM/°C
Bridge Offset Temperature Coefficient	TCO	$T_A = -40$ °C to 125 °C, w/o set/reset	-	500	-	PPM/°C
		$T_A = -40$ °C to 125 °C, w/ set/reset	-	10	-	
Resistance Temperature Coefficient	TCR	$T_A = -40$ °C to 125 °C	-	2700	-	PPM/°C
Cross-Axis Effect	X_B	Cross field = 1 Gs	-	± 0.5	-	%FS

6. Typical Output Characteristics

Figure 4 shows the response of the AMR2302 to an applied magnetic field. (Applied field = ± 20 Gs, analysis field = ± 6 Gs, and $V_{CC} = 5$ V).

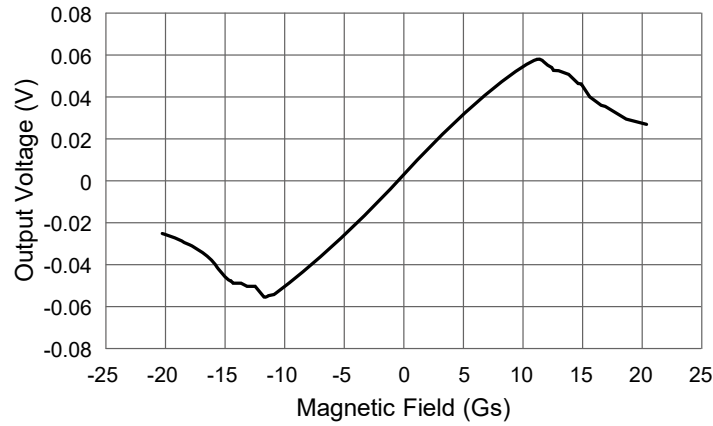

Figure 4. AMR2302 output vs. applied field

Typical voltage noise density

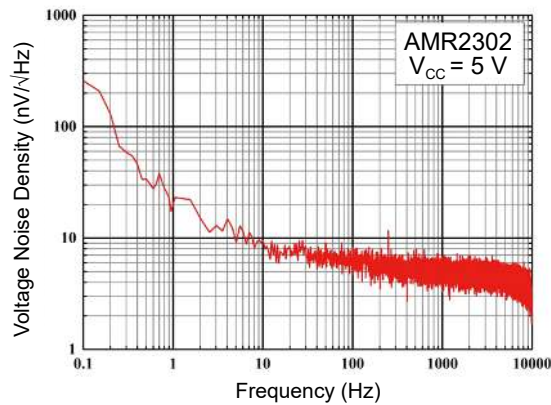

Figure 5. AMR2302 voltage noise density vs. frequency

Typical magnetic noise density

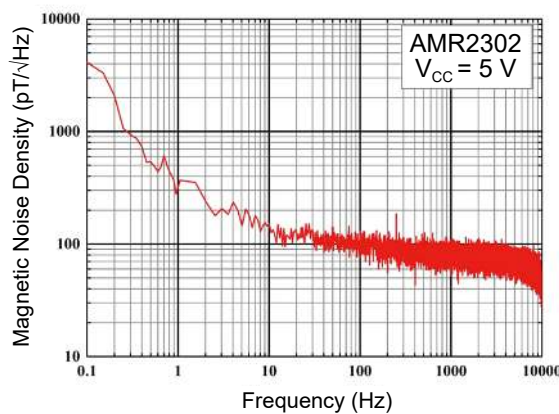

Figure 6. AMR2302 magnetic noise density vs. frequency

7. Application Information

A voltage pulse of 5 V for 2 μ s in 10 kHz can be select as the set/reset signal. The pulse voltage, pulse width and duty cycle can be adjusted in a certain range. A typical drive circuit is shown in Figure 7.

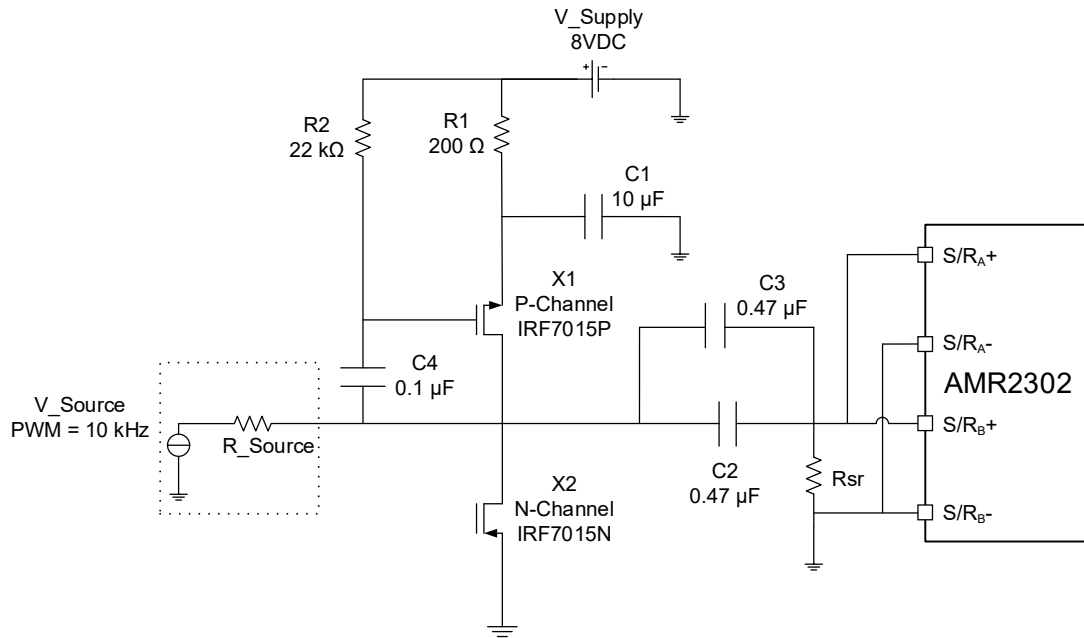

Figure 7. Set/reset drive circuit of AMR2302

The circuit will generate 5 V set/reset pulses, as illustrated in figure 8.

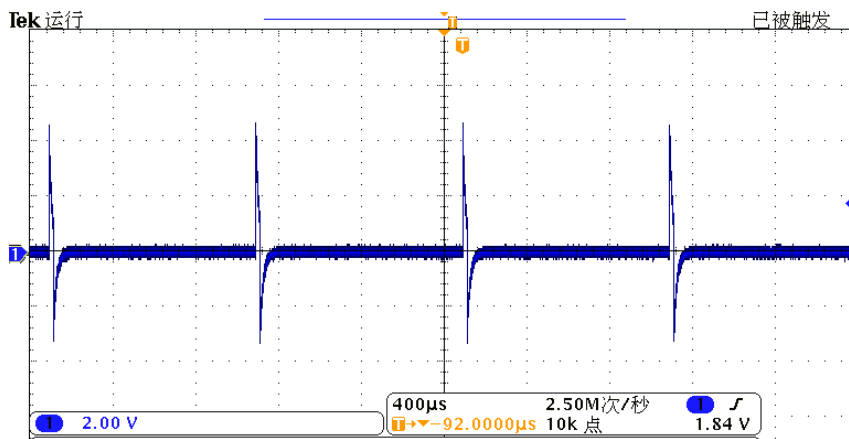

Figure 8. Set/reset voltage pulses waveform

When set-only or reset-only pulse is applied, the set- and reset- pulse is switchable by reversing the set/reset input.

8. Dimensions

SOP16 Package

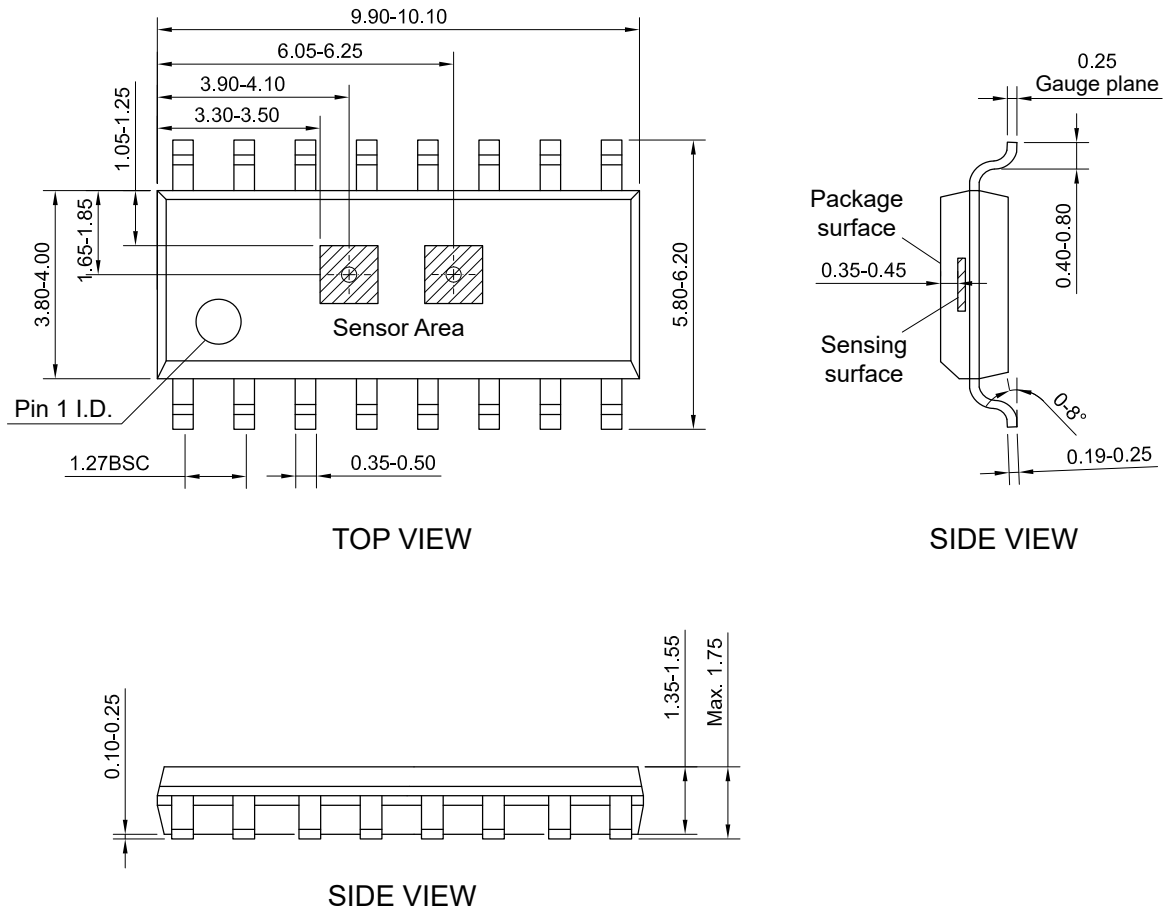

Figure 9. Package outline of SOP16 (unit: mm)

Copyright © 2022 by MultiDimension Technology Co., Ltd.

Information furnished herein by MultiDimension Technology Co., Ltd. (hereinafter MDT) is believed to be accurate and reliable. However, MDT disclaims any and all warranties and liabilities of any kind, with respect to any examples, hints or any performance or use of technical data as described herein and/or any information regarding the application of the product, including without limitation warranties of non-infringement of intellectual property rights of any third party. This document neither conveys nor implies any license under patent or other industrial or intellectual property rights. Customer or any third-party must further determine the suitability of the MDT products for its applications to avoid the applications default of customer or third-party. MDT accept no liability in this respect.

MDT does not assume any liabilities of any indirect, incidental, punitive, special or consequential damages (including without limitation of lost profits, lost savings, business interruption, costs related to the removal or replacement of any products or rework charges) whether or not such damages are based on tort (including negligence), warranty, breach of contract or any other legal theory. Notwithstanding any damages that customer might incur for any reason whatsoever, MDT's aggregate and cumulative liability towards customer for the products described herein shall be limited in accordance with the terms and conditions of commercial sale of MDT.

Absolute maximum ratings are the extreme limits the device will withstand without damage to the MDT product. However, the electrical and mechanical characteristics are not guaranteed as the maximum limits (above recommended operating conditions) are approached. MDT disclaims any and all warranties and liabilities of the MDT product will operate at absolute maximum ratings.

Specifications may change without notice.

Please download latest document from our official website www.dowaytech.com/en.

Recycling

The product(s) in this document need to be handed over to a qualified solid waste management services company for recycling in accordance with relevant regulations on waste classification after the end of the product(s) life.



No.2 Guangdong Road, Zhangjiagang Free Trade Zone, Jiangsu, China

Web: www.dowaytech.com/en E-mail: info@dowaytech.com

