

MIL-C-39012/59

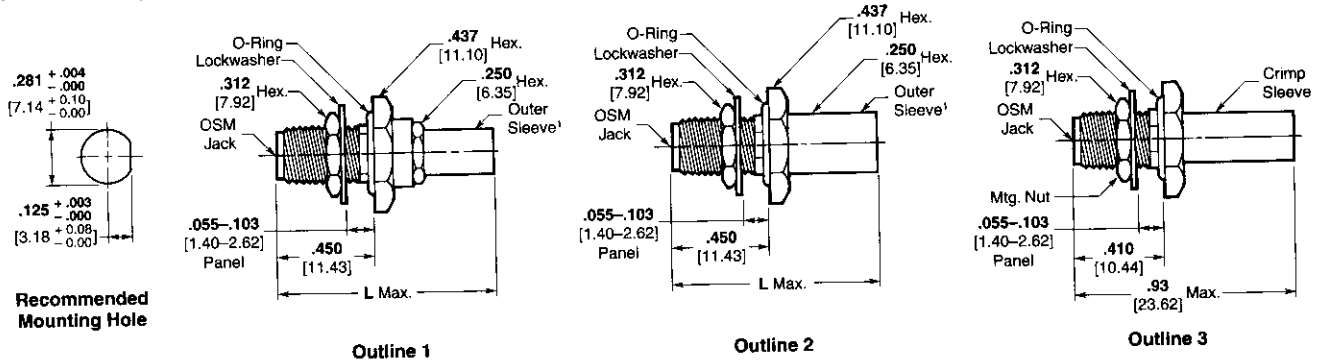

Recommended Mounting Hole

Military Part No.	AMP Part No.	M/A-COM ¹ Part No. (Ref. Only)	Outline	Cat. ¹	RG/U Cable	Dim. L
-3006	1051981-1	2034-8006-92	1	A	178	.960 [24.38]
-3007	1051982-1	2034-8007-92	1	A	174, 316	.960 [24.38]
-3008	1051983-1	2034-8008-90	2	A	122	.960 [24.38]
-3009	1051984-1	2034-8009-90	2	A	58, 142, 223	.960 [24.38]
-3010	1051985-1	2034-8010-90	2	A	303	.960 [24.38]
B3011	1362216-1	2034-8011-92	1	B	178	1.265 [32.13]
B3012	1051986-1	2034-8012-92	1	B	174, 316	1.265 [32.13]
B3013	1083993-1	2034-8013-92	2	B	122	1.265 [32.13]
B3014	1331293-1	2034-8014-92	2	B	58	1.265 [32.13]
B3015	1253627-1	2034-8015-92	2	B	142	1.265 [32.13]
B3016	1221165-1	2034-8016-92	2	B	223	1.265 [32.13]
B3017	1484542-1	2034-8017-92	2	B	303	1.265 [32.13]
B3018	1051987-1	2034-8018-92	1	B	178	1.265 [32.13]
B3019	1051988-1	2034-8019-92	1	B	174, 316	1.265 [32.13]
B3020	1484543-1	2034-8020-92	2	B	122	1.265 [32.13]

Military Part No.	AMP Part No.	M/A-COM ¹ Part No. (Ref. Only)	Outline	Cat. ¹	RG/U Cable	Dim. L
B3021	1087842-1	2034-8021-92	2	B	58	1.265 [32.13]
B3022	1051989-1	2034-8022-92	2	B	142	1.265 [32.13]
B3023	1051990-1	2034-8023-92	2	B	223	1.265 [32.13]
B3024	1051991-1	2034-8024-92	2	B	303	1.265 [32.13]
-3025	1051992-1	2034-8025-92	1	C	178	1.125 [28.58]
-3026	1051994-1	2034-8026-92	1	C	174, 316	1.125 [28.58]
-3027	1051995-1	2034-8027-92	2	C	122	1.125 [28.58]
-3028	1051996-1	2034-8028-92	2	C	142, 223	1.125 [28.58]
-3029	1051997-1	2034-8029-92	2	C	58, 303	1.125 [28.58]
-3502	1051998-1	2034-8052-92	2	D	142, 400	1.265 [32.13]
-4026	1-1532129-3 ²	—	3	C	174, 316	—
-4027	1-1532129-4 ³	—	3	C	122	—
-4028	1-1532129-5 ⁴	—	3	C	142, 223	—
-4029	1-1532129-6 ⁴	—	3	C	58, 303	—

¹ Category A: solder sleeve; Categories B, C and D: crimp sleeve.
² Crimp tool M22520/5-01 and M22520/5-35 Closure B. Alternate crimp tool M22520/10-01 and M22520/10-13.
³ Crimp tool M22520/5-01 and M22520/5-41 Closure B. Alternate crimp tool M22520/10-01 and M22520/10-17.
⁴ Crimp tool M22520/5-01 and M22520/5-19 Closure B. Alternate crimp tool M22520/10-01 and M22520/10-21.
⁵ -92 indicates passivated stainless steel finish.
 -90 indicates gold plated finish.
 See page 7003 for description of categories and pages 7059-7064 for tooling (unless noted otherwise).