

PART NUMBER DATA							
CIRCUITS	PART NUMBER	ENGINEERING NUMBER	COLOR	A IN	mm	B IN	mm
2	398805502	M611-00-2-02-1	BLACK	.40	10.2	.200	5.08
3	398805503	M611-00-2-03-1	BLACK	.60	15.2	.400	10.16
4	398805504	M611-00-2-04-1	BLACK	.80	20.3	.600	15.24
5	398805505	M611-00-2-05-1	BLACK	1.00	25.4	.800	20.32
6	398805506	M611-00-2-06-1	BLACK	1.20	30.5	1.000	25.40

REF. LAST 2 DIGITS OF PART NUMBER EQUALS NUMBER OF POLES

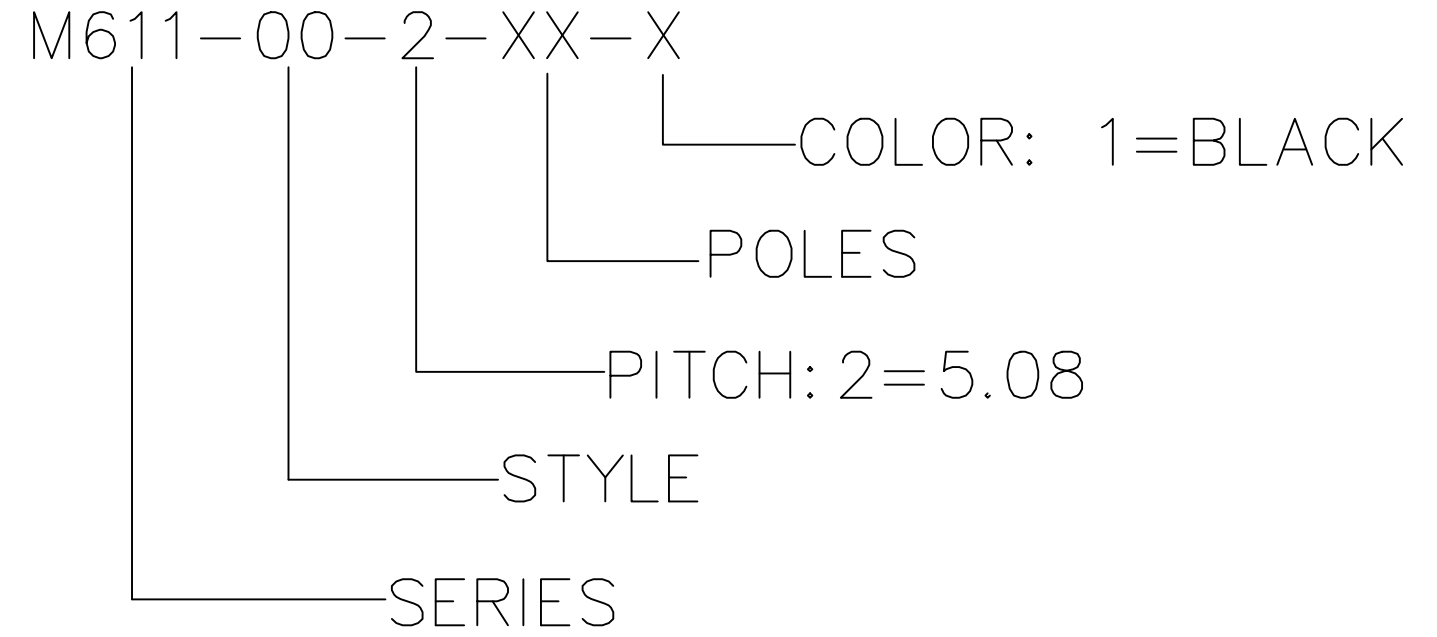

CONTACT FACTORY FOR OPTIONAL COLORS

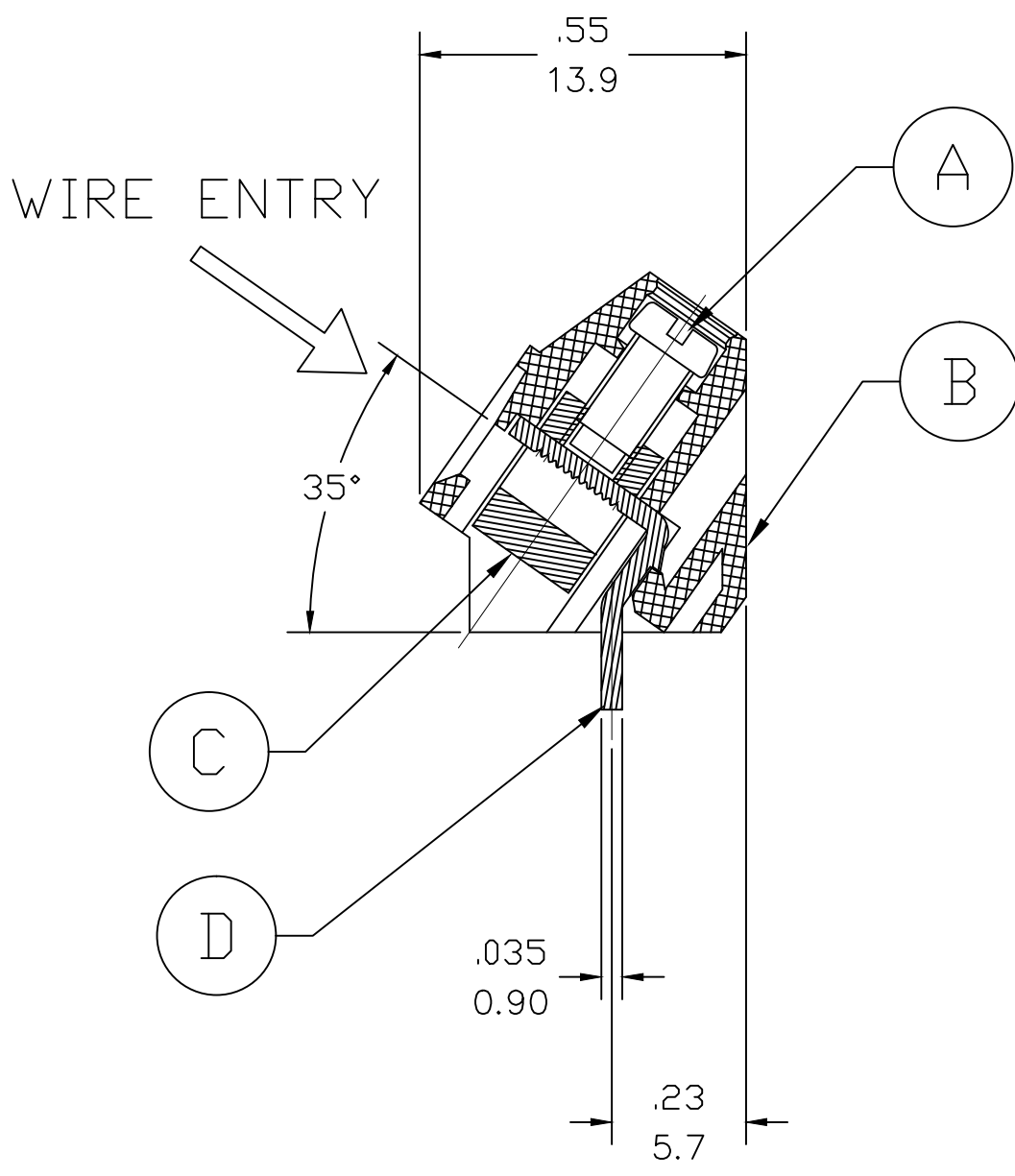
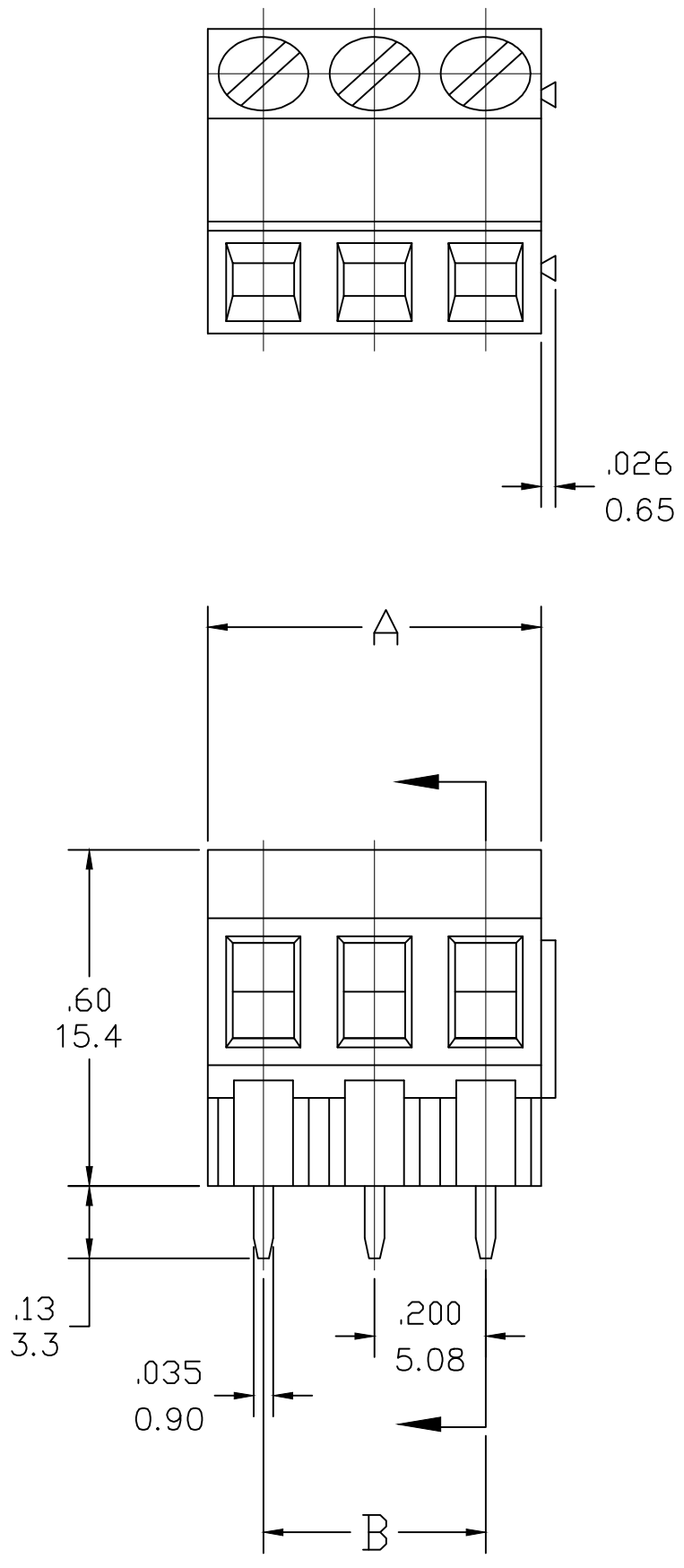
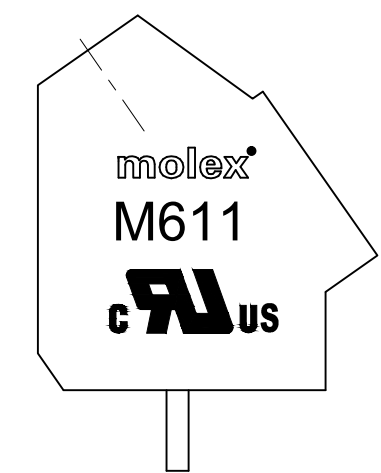
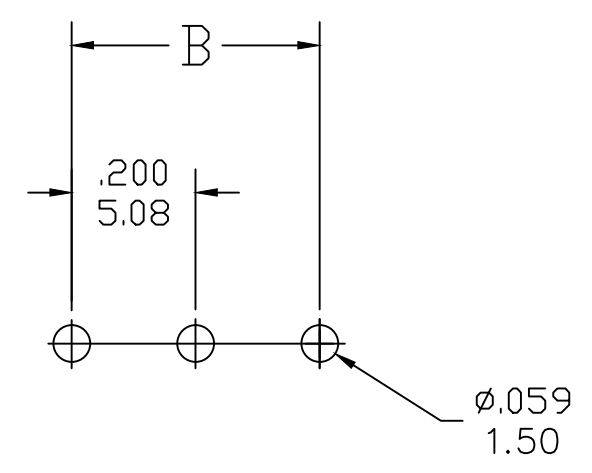

SPECIFICATIONS

- MATERIAL:
  - A. SCREW: STEEL, M3, ZINC PLATED
  - B. BODY: PA66, UL94 V-0
  - C. BLOCK: BRASS, NICKEL PLATED
  - D. TERMINAL: BRASS, TIN PLATED
- WIRE RATING: 30-14AWG
- ELECTRICAL RATING: 300V, 10A
- POWER-FREQUENCY WITHSTAND: AC 2500V/1MIN
- INSULATION RESISTANCE: DC500V 500MΩ OR ABOVE
- RATED IMPULSE VOLTAGE: 4000V/MINUS AND PLUS 5 TIMES EACH
- WIRE STRIP LENGTH: .31 IN. (8.0mm)
- MAX. TORQUE: 4.4 LBF.IN (0.5 N.M)
- OPERATING TEMPERATURE: -40°C TO +105°C
- MAX SOLDERING: 260°C (+500°F) FOR 5 SECONDS
- DIMS SHOWN ARE FOR REFERENCE ONLY

TOLERANCES			
MM	TOL	INCH	TOL
0-6	±0.25	0-.24	±.010
>6-30	±0.40	.24-1.18	±.016
>30-120	±0.50	1.18-4.76	±.020
>120	±0.80	>4.76	±.031

REVISED DOC TOL EC NO.: ICG2017-0881 DRWN: ABENJAMI CHKD: --- APPR: BRUPERT 2015/04/22 DESCRIPTION REV	QUALITY SYMBOL	GENERAL TOLERANCES (UNLESS SPECIFIED)	DIMENSION STYLE IN/MM	SCALE ---	DESIGN UNITS METRIC	THIRD ANGLE PROJECTION
	▽=0	4 PLACES ±--- ±---	DRAWN BY RSTONE DATE 2014/10/13	TITLE	5.08MM EURO TERM. BLOCK	
	∇=0	3 PLACES ±--- ±---	CHECKED BY B ARDEN DATE 2014/10/24	35 DEG WIRE ENTRY		
		2 PLACES ±--- ±---	APPROVED BY JFMURPHY DATE 2015/04/22	MOLEX INCORPORATED		
		1 PLACE ±--- ±---	MATERIAL NO. SEE CHART	DOCUMENT NO. SD-39880-014	SHEET NO. 1 OF 1	
		ANGULAR ±---°	THIS DRAWING CONTAINS INFORMATION THAT IS PROPRIETARY TO MOLEX INCORPORATED AND SHOULD NOT BE USED WITHOUT WRITTEN PERMISSION			
		DRAFT WHERE APPLICABLE MUST REMAIN WITHIN DIMENSIONS				