

LOC	DIST	REVISIONS					
AD	00	P	LTR	DESCRIPTION	DATE	DWN	APVD
		D		ECO-06-7871	28SEP2006	MB	JO
		E		ECO-07-006955	11APR2007	RB	JO

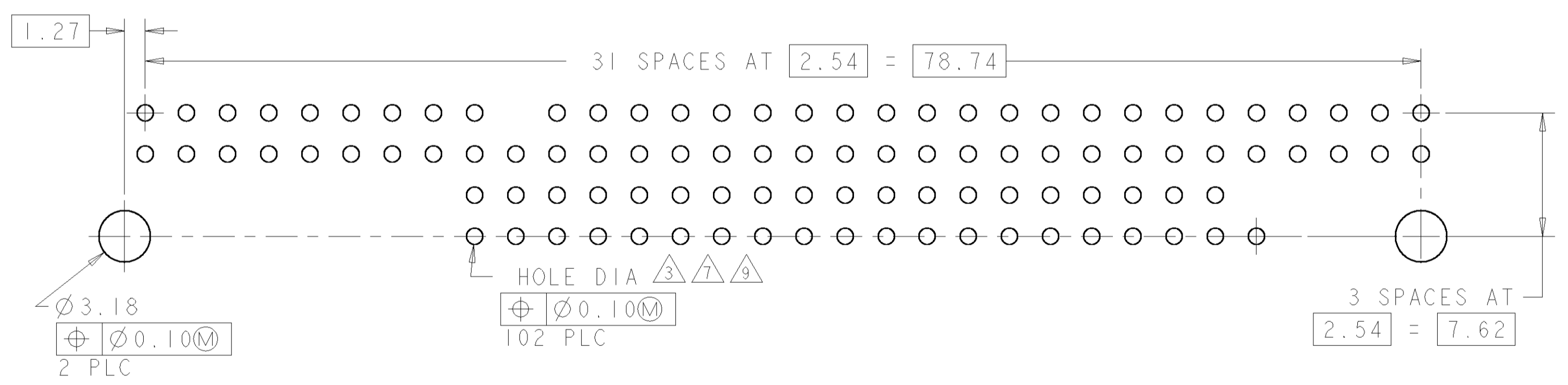

RECOMMENDED PCB LAYOUT FOR 1375794-1 & -3

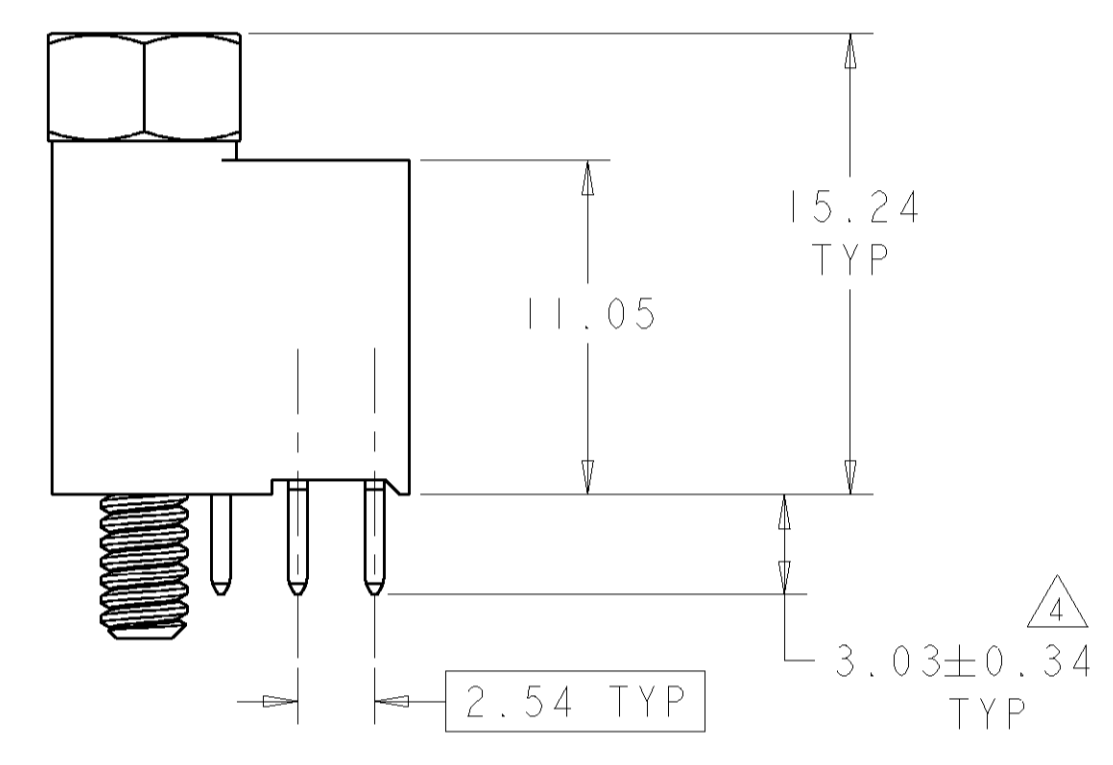
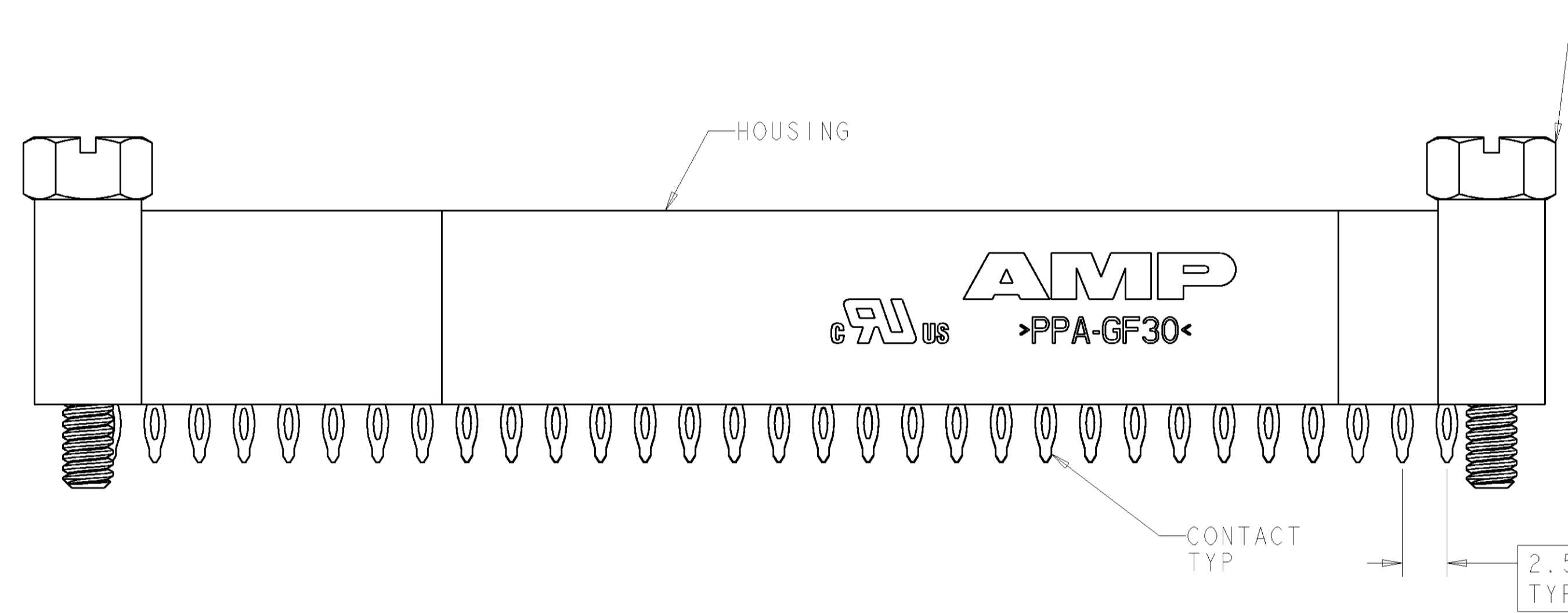
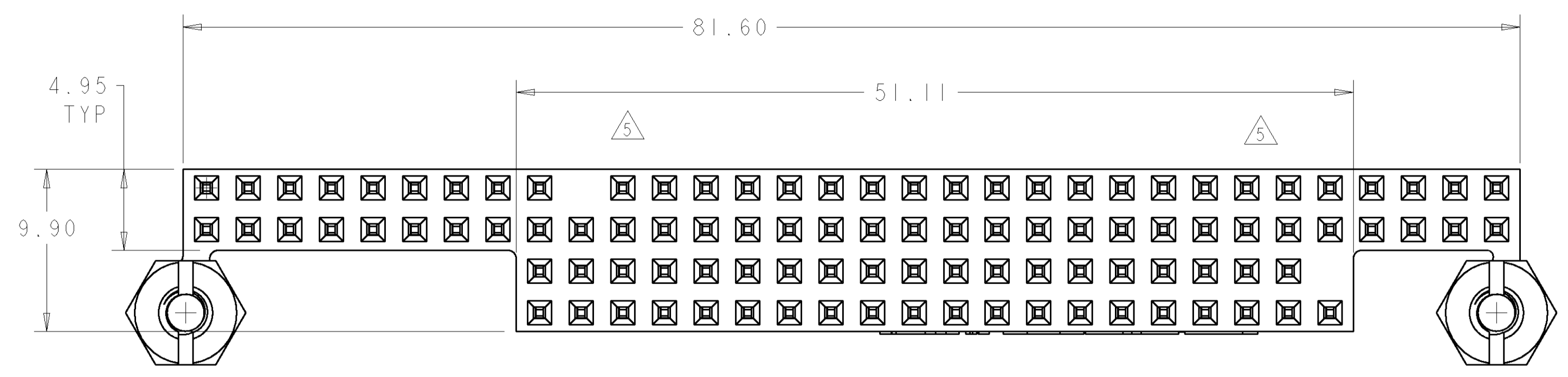
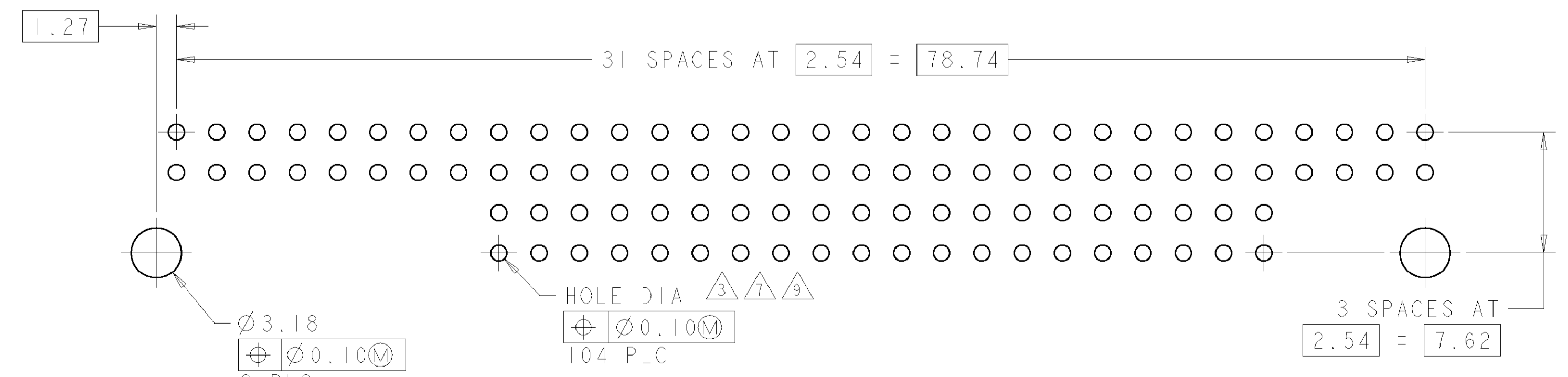

RECOMMENDED PCB LAYOUT FOR 1375794-2 & -4

- △ HOUSING: HIGH TEMPERATURE, GLASS FILLED NYLON, COLOR: BLACK.
CONTACTS: PHOSPHOR BRONZE.
SCREWLOCKS: STEEL.
- △ CONTACTS: 0.00038 MIN GOLD ON MATING RECEPTACLE END, 0.00254 BRIGHT TIN-LEAD ON REMAINDER, ALL OVER 0.00127 NICKEL.
SCREWLOCKS: CLEAR CHROMATE OVER ZINC.
- △ PCB HOLE RECOMMENDATIONS:
A. DRILL HOLE DIAMETER TO BE 1.15±0.02.
B. PLATING TO BE 0.005 MIN TIN-LEAD OVER 0.025-0.075 COPPER.
C. RECOMMENDED FINISH HOLE SIZE IS 1.03±0.08.
- △ DIMENSION AFTER SEATING TO PCB.
- △ NO CONTACT IN THIS POSITION, FOR PART NUMBER 1375794-1 & -3, ONLY
- △ CONTACTS: 0.00038 MIN GOLD ON MATING RECEPTACLE END, 0.00254-0.00508 MATTE TIN ON REMAINDER, ALL OVER 0.00127 NICKEL.
SCREWLOCKS: CLEAR CHROMATE OVER ZINC.
- △ PCB HOLE RECOMMENDATIONS FOR SILVER IMMERSION PLATING:
A. DRILL HOLE DIAMETER TO BE 1.20±0.02.
B. PLATING TO BE 0.0001524-0.0004064 SILVER OVER 0.0508±0.0254 COPPER.
C. RECOMMENDED FINISH HOLE SIZE IS 1.10-1.19.
- △ TO BE USED ON SILVER IMMERSION PLATED PCB'S (NOTE 7).
- △ PCB HOLE RECOMMENDATIONS FOR ENIG PLATING:
A. DRILL HOLE DIAMETER TO BE 1.20±0.02.
B. PLATING TO BE 0.000051-0.000127 GOLD OVER 0.00305-0.00610 NICKEL ALL OVER 0.0508±0.0254 COPPER.
C. RECOMMENDED FINISH HOLE SIZE IS 1.10-1.19.
- △ TO BE USED ON STANDARD PCB (NOTE 3) OR ENIG PLATED PCB (NOTE 9).

FINISH	KEYED CIRCUITS	PART NO
8	6	NO 1375794-4
6	6	YES 5 1375794-3
10	2	NO 1375794-2
10	2	YES 5 1375794-1

DIMENSIONS:		TOLERANCES UNLESS OTHERWISE SPECIFIED:		DWN: W.G. LENKER 02JUN2000		Tyco Electronics	
mm		0 PLC ±		ENR: L.BREKOSKY 15JAN2001		Harrisburg, PA 17105-3608	
Ø		1 PLC ±0.13		APVD: -		NAME: ASSEMBLY, PC/104, NON-STACKTHROUGH CONTACTS, 2 STANDOFFS, PRESS FIT	
MATERIAL		FINISH		PRODUCT SPEC: 108-1956		SIZE: CAGE CODE: DRAWING NO: RESTRICTED TO	
1		6/2		APPLICATION SPEC: 114-13021		A1 00779 C=1375794	
				WEIGHT: -		SCALE: 4:1 SHEET 1 OF 1 REV E	
				CUSTOMER DRAWING			