

A-772 Series Battery Contactor — Discharge Overload, Rated up to 200 Amps, 28 Vdc

Product Facts

- SPST NO
- Gasket sealed
- Auxiliary contacts available
- Limits overload current duration

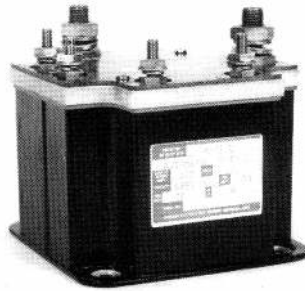

Performance Data

Electrical Characteristics

- Main Contacts —**
Contact Arrangement — SPST NO
Rated Operating Voltage — 28 Vdc
Resistive Rating — 200 Amps
Auxiliary Contacts —
Aux. Contact Arrangement — SPST NC
Rated Operating Voltage — 28 Vdc
Resistive Rating — 5 Amps

General Characteristics

- Temperature Range —** -55°C to +71°C
Operating Cycles (Life) at Rated Resistive Load — 50,000 cycles
Operating Cycles (Life) Mechanical — 100,000 cycles
Electrical — 50,000 min.
Weight, Max. — 2 lbs. 13 oz.

Coil Characteristics

- Duty Cycle —** Continuous
Operating Voltage, Max. — 30 V
Operating Voltage, Min. — 24 V
Pickup Voltage @ 25°C, Max. — 16 V
Dropout Voltage — 1 to 7 V
Overload Sensor Type — Latching
Polarized — Discharge
Trip — 300 Amps ± 10%
Time Delay — 900 to 1,100 msec

Sensor Contacts, Aux.

- Sensor Contact Arrangement —** SPST NO
Rated Operating Voltage — 28 Vdc
Resistive Rating — 3 Amps
Reset Rating, Max. — 18 V

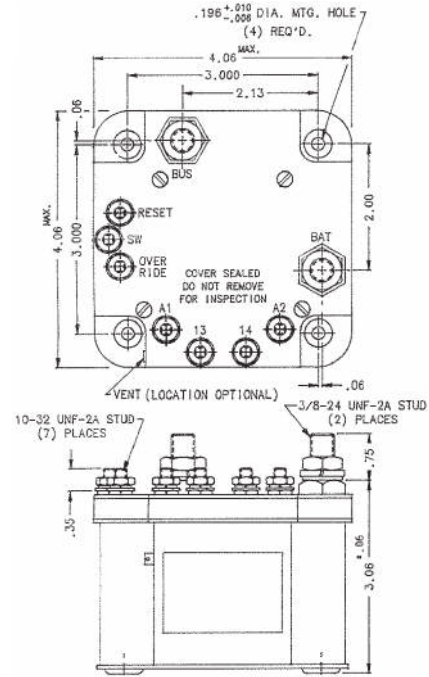

Mounting Style A

Circuit Configurations (Consult factory for other available circuit configurations)

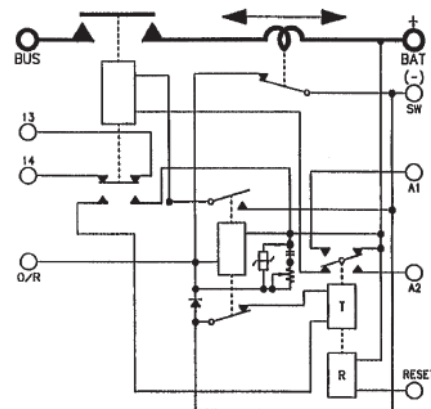

Circuit Configuration 1

For factory-direct application assistance, phone 419-521-9500 or fax 419-526-2749.

HARTMAN Part Number	Construction Type	Mounting Style	Coil Type	Circuit Config.	TE Part Number
A-772XTB	Gasket/Vented	A	Continuous	1	1616545-1