

## RF CHARACTERISTICS

Frequency range : **0 - 18 GHz**  
Impedance : **50 Ohms**

Frequency (GHz)	DC - 3	3 - 8	8 - 12.4	12.4 - 18
VSWR max	<b>1.20</b>	<b>1.30</b>	<b>1.40</b>	<b>1.50</b>
Insertion loss max	<b>0.20 dB</b>	<b>0.30 dB</b>	<b>0.40 dB</b>	<b>0.50 dB</b>
Isolation min	<b>80 dB</b>	<b>70 dB</b>	<b>65 dB</b>	<b>60 dB</b>
Average power (*)	<b>240 W</b>	<b>150 W</b>	<b>120 W</b>	<b>100 W</b>

## ELECTRICAL CHARACTERISTICS

Actuator : **LATCHING**  
Nominal current \*\* : **125 mA**  
Actuator voltage (Vcc) : **28V (24 to 30V) / POSITIVE COMMON**  
Terminals : **9 pins D-SUB male connector**  
Indicator rating : **1 W / 30 V / 100 mA**

## MECHANICAL CHARACTERISTICS

Connectors : **SMA female per MIL-C 39012**  
Life : **2.5 million cycles**  
Switching Time\*\*\* : **< 15 ms**  
Construction : **Splashproof**  
Weight : **< 100 g**

## ENVIRONMENTAL CHARACTERISTICS

Operating temperature range : **-40°C to +85°C**  
Storage temperature range : **-55°C to +85°C**

(\* Average power at 25°C per RF Path)

(\*\* At 25° C ±10%)

(\*\*\* Nominal voltage ; 25° C)



PAGE 2/2

ISSUE 22-03-22

SERIE : DPDT

PART NUMBER : R577443045

DRAWING

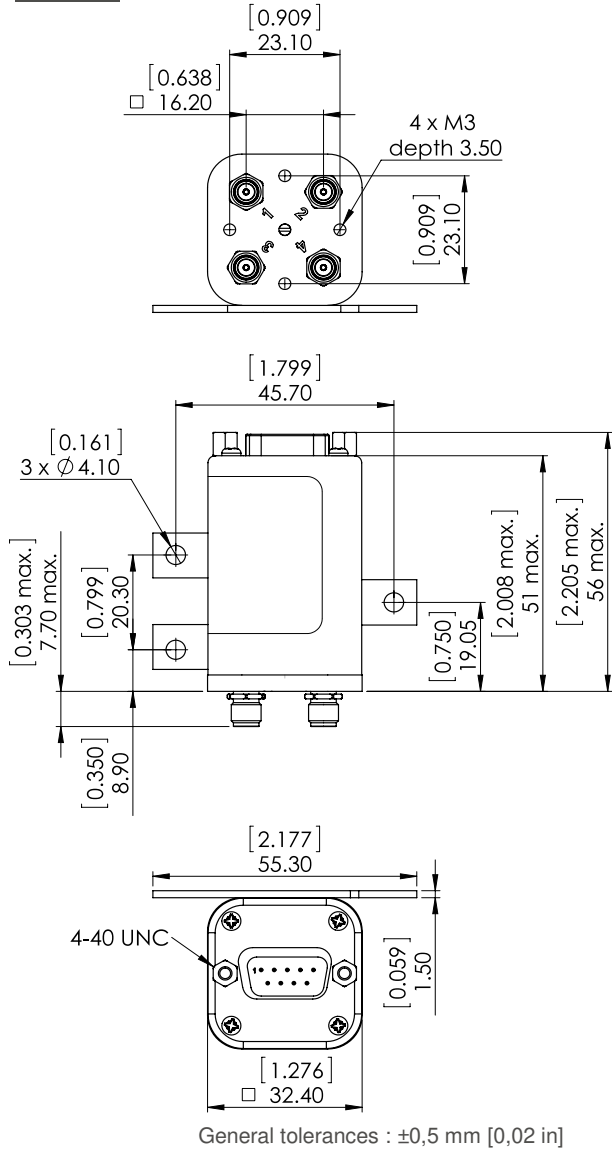

**LABEL**

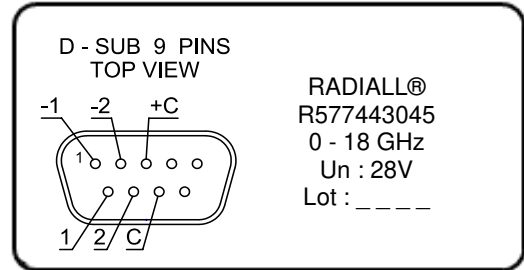

SCHEMATIC DIAGRAM

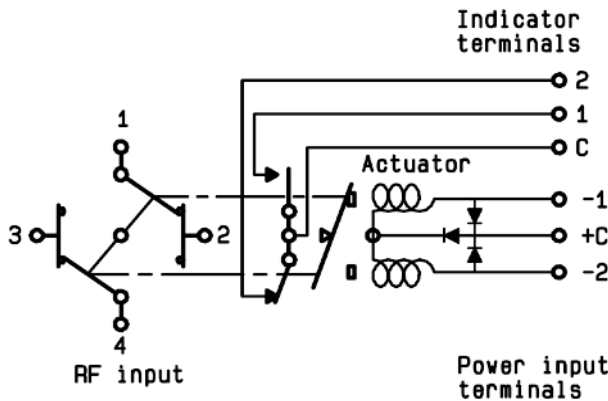

Voltage	RF Continuity	Ind.
+C -1	1 ↔ 3 / 2 ↔ 4	C.1
+C -2	1 ↔ 2 / 3 ↔ 4	C.2