

FEATURES

- accurate clamping to within ± 1 mV
- less than 1 mV clamping distortion
- variable clamping range ($V_{EE} + 3.0$ V to $V_{CC} - 4.5$ V)
- ultra low differential gain and differential phase
- fast recovery from sudden changes in DC offsets
- less than $\pm 0.15^\circ$ phase delay variation at 3.58 MHz
- ± 0.1 dB flatness to 80 MHz
- ± 4.5 V to ± 13.2 V supply voltage range
- Pb-free and Green

PIN CONNECTIONS

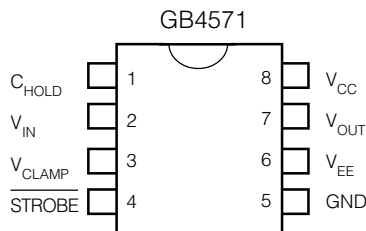

AVAILABLE PACKAGING

- 8 pin PDIP
- 8 pin SOIC

ORDERING INFORMATION

Part Number	Package	Temperature Range	Pb-free and Green
GB4571-CDA	8 pin PDIP	0° to 70°C	No
GB4571-CKA	8 pin SOIC	0° to 70°C	No
GB4571-CTA	8 pin SOIC Tape	0° to 70°C	No
GB4571-CKAE3	8 pin SOIC	0° to 70°C	Yes

DESCRIPTION

The GB4571 is a high performance video buffer with DC restore used primarily for accurate back porch clamping. Key features include operation from ± 4.5 V to ± 13.2 V supply voltages, fast recovery from sudden changes in DC offset, ± 0.1 dB flatness to 80 MHz and availability of industry standard DIP and SOIC packages.

In the typical back porch clamping application, a negative going back porch pulse from an external sync separator (such as the GS4881 or GS4882) is applied to the GB4571's STROBE input. While STROBE is low, the GB4571 determines the correct DC level shift that should be applied to the input signal by integrating over the entire back porch period. This reduces sensitivity to noise and improves the accuracy of the DC restoration compared to systems using sample and hold techniques. Typical clamping accuracy of ± 1 mV is achieved by the GB4571.

APPLICATIONS

- Clamping of NTSC, PAL, SECAM & RGB Video Signals
- Multimedia Graphics Overlay
- Production Switchers
- Linear Keyers

SIMPLIFIED CIRCUIT DIAGRAM

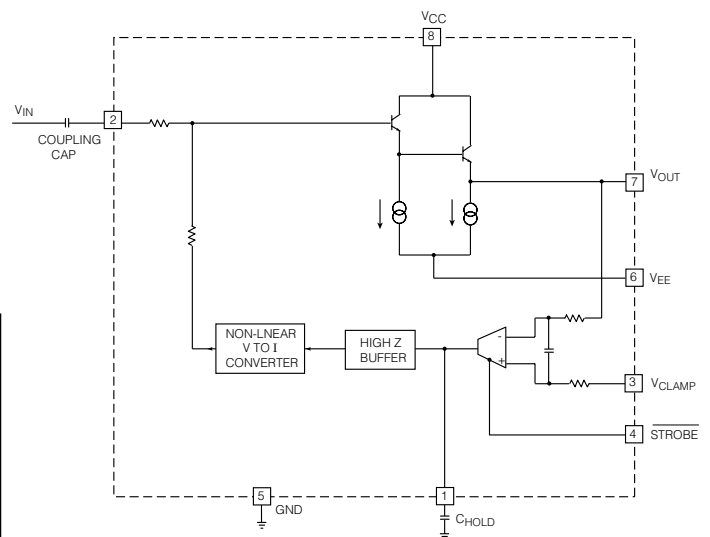

ABSOLUTE MAXIMUM RATINGS

PARAMETER	VALUE/UNITS
Supply Voltage	± 13.5 V
Operating Temperature Range	$0^{\circ}\text{C} \leq T_A \leq 70^{\circ}\text{C}$
Storage Temperature Range	$-65^{\circ}\text{C} \leq T_S \leq 150^{\circ}\text{C}$
Lead Temperature (soldering, 10 seconds)	260°C
Differential Video Input Voltage	± 5 V
Strobe Input Voltage	$-V_S \leq V_{\text{STROBE}} \leq +V_S$

CAUTION
ELECTROSTATIC
SENSITIVE DEVICES
DO NOT OPEN PACKAGES OR HANDLE
EXCEPT AT A STATIC-FREE WORKSTATION



ELECTRICAL CHARACTERISTICS $V_S = \pm 5$ V, $T_A = 0^{\circ}$ to 70°C , $R_L = 10\text{k}\Omega$, $C_L = 10$ pF, unless otherwise shown.

	PARAMETER	SYMBOL	CONDITIONS	MIN	TYP	MAX	UNITS				
POWER SUPPLIES	Supply Voltage	$\pm V_S$		± 4.5	± 5.0	± 13.2	V				
	+ Supply Current	I+		-	10	15	mA				
	- Supply Current	I-		-	10	15	mA				
SIGNAL PATH	Small Signal B.W. (flattened response)	B.W.	± 0.1 dB after insertion loss, $V_{\text{IN}} = 100$ mV p-p	80	-	-	MHz				
	Phase Delay	ϕ_D	at 3.58 MHz and 4.43 MHz	-2.85	-3.0	-3.15	deg				
	Differential Gain	δg	at 3.58 MHz and 4.43 MHz	-	0.01	0.03	%				
	Differential Phase	δp	at 3.58 MHz and 4.43 MHz	-	0.01	0.05	deg				
	Input Voltage	V_{IN}		$V_{\text{EE}} + 3$	-	$V_{\text{CC}} - 3$	V				
	Input Resistance	R_{IN}		25	-	-	k Ω				
	Input Capacitance	C_{IN}		-	2.0	-	pF				
	Output Resistance	R_{OUT}	$f = 0$ to 1 MHz $f = 100$ MHz	-	8.6 20	10 40	Ω Ω				
	Insertion Loss	I.L.	$f = 100$ kHz	-	0.03	0.05	dB				
	Power Supply Rejection Ratio	PSRR	$f = 1$ kHz $f = 10$ MHz	50 20	- -	- -	dB dB				
	PP Signal / RMS Noise	S/N	$V_{\text{SIG}} = 1$ Vp-p	75	-	-	dB				
	Strobe Pulse Width	t_{PWL}	Active low	2.0	2.5	-	μs				
	Accuracy		$V_{\text{IN}} = 0.5\text{V}$ to 2Vp-p , STROBE pulses at H rate	-	± 1	± 2	mV				
	Recovery Time		Scan rate 15.7kHz & $2\mu\text{s}$ strobe pulses 0.5V offset	-	1	3	ms				
Clamping Distortion		0.1V offset Distortion amplitude	-	-	± 1	μs mV					
V_{CLAMP}							Distortion duration (amp. within 0.1 mV)	-	-	3	μs
STROBE	Clamp Voltage Range	V_{CLAMP}	$V_{\text{IN}} = 1$ Vp-p	$V_{\text{EE}} + 3$	-	$V_{\text{CC}} - 4.5$	V				
	Input Logic High	V_{IH}		1.8	-	-	V				
	Input Logic Low	V_{IL}		-	-	0.8	V				

- NOTE:**
- V_A or $B = +1$ Vp-p output taken from OUTPUT
 - $V_C = +1$ Vp-p output taken from V_A or V_B

DETAILED DESCRIPTION

The GB4571 is intended for video applications requiring precision DC restoration. The GB4571's signal path consists of a simple Darlington emitter follower for maximum bandwidth performance. With this configuration, the GB4571's small signal frequency response remains with ± 0.1 dB of 0 dB out to 80 MHz.

Optimal frequency response for the GB4571 occurs with load capacitance in the range of 18 pF. For smaller loads, an external capacitor can be added to maintain the bandwidth of the device. As shown in Figure 1, a small resistor, R_{OUT} , should be included in series with the GB4571 output to obtain optimal response flatness. For a nominal load of 18 pF, R_{OUT} should be chosen to be approximately 30 Ω .

The DC restoration function is achieved through the use of a strobed operational transconductance amplifier (OTA). The OTA receives its input from a differential low pass filter. This filter has a corner frequency of 600 kHz which attenuates the color burst and any high frequency noise that may be present in the signal. One input to the low pass filter senses the output of the GB4571, while the other input is connected to the clamp voltage reference. When enabled by taking \overline{STROBE} low, the OTA sources or sinks current depending on whether the output of the GB4571 is below or above V_{CLAMP} respectively.

The output current from the OTA is integrated by the hold capacitor connected to pin 1, C_{HOLD} . C_{HOLD} develops a corrective voltage during the period when the clamp is enabled and holds the corrective voltage while the clamp is disabled.

The resulting voltage is buffered and fed back to the GB4571 input through a non-linear V to I converter. This feedback current transfers charge to the GB4571's input coupling capacitor which act as a DC reservoir for corrective level shifts.

The non - linear V to I converter feeds back larger corrective currents to the GB4571's input for larger differences between V_{CLAMP} and V_{IN} than it does for proportionally smaller differences between V_{CLAMP} and V_{IN} voltages. The non-linear V to I converter thus provides for substantially faster recovery from large changes in input signal DC offset while maintaining the overall stability of the device during near-steady-state operation.

A 400 Ω resistor in series with the input provides some phase advance to improve the stability of the DC restoration feedback loop. The ratio of the capacitors $C_{IN}:C_{HOLD}$ should be maintained at approximately 20,000:1 to ensure closed loop stability. Additional reductions in recovery time from changes in DC offset may be obtained by reducing the values of C_{IN} and C_{HOLD} .

In the application shown in Figure 1, the \overline{STROBE} signal is provided by the back porch pulse of the GS4881 sync separator. The GS4881 generates back porch pulses which remain at horizontal rate throughout the vertical interval. Constant rate \overline{STROBE} pulses eliminate the possibility of introducing a DC offset due to a change in duty cycle.

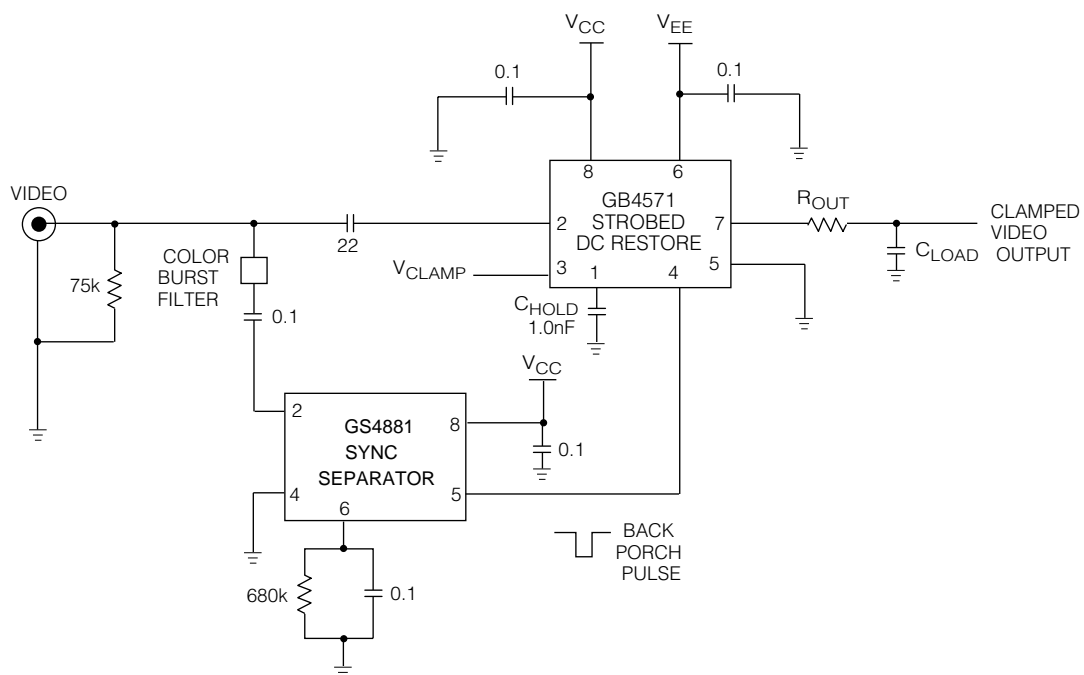

All resistors in ohms, all capacitors in microfarads unless otherwise stated.

Fig. 1 GB4571 Typical Application Circuit

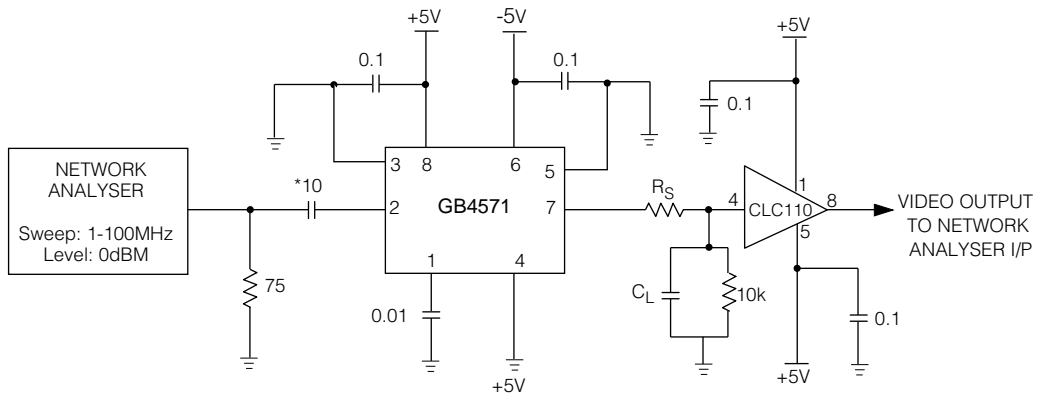

All resistors in ohms, all capacitors in microfarads unless otherwise stated.

* This input capacitor must be shorted when performing Differential Gain and Differential Phase tests.

Fig. 2 Frequency Response Test Circuit

GB4571 TYPICAL PERFORMANCE CURVES ($V_S = \pm 5\text{ V}$, unless otherwise specified)

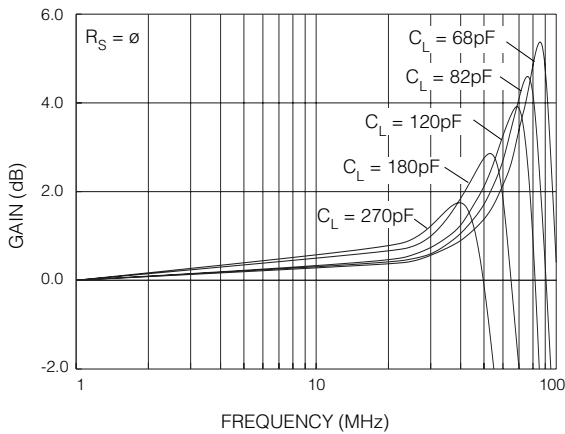

Fig. 3 Gain vs Frequency

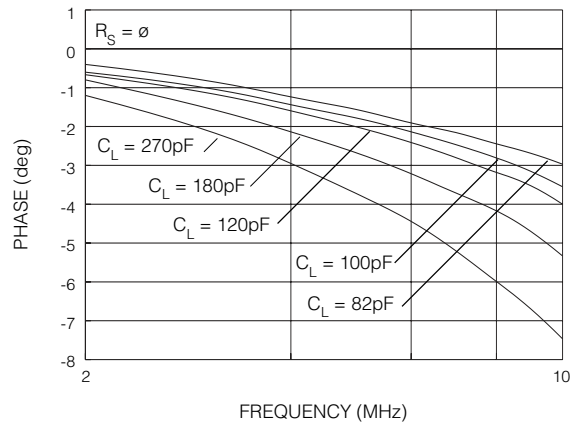

Fig. 4 Phase vs Frequency

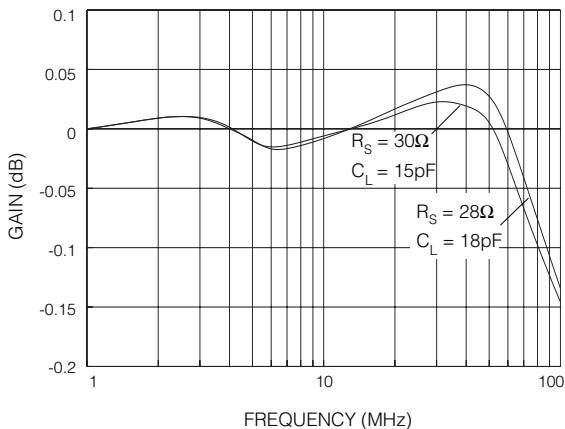

Fig. 5 Flattened Frequency Response

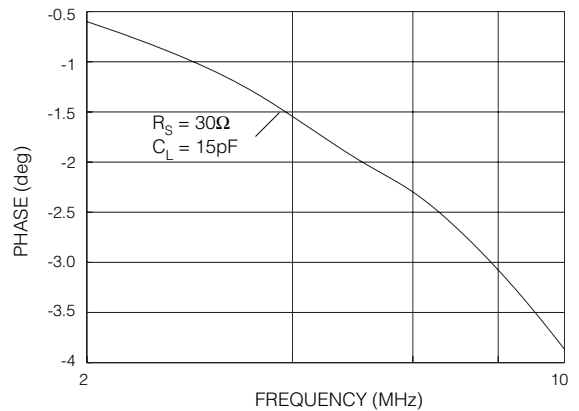

Fig. 6 Phase vs Frequency

DOCUMENT IDENTIFICATION

PRODUCT PROPOSAL

This data has been compiled for market investigation purposes only, and does not constitute an offer for sale.

ADVANCE INFORMATION NOTE

This product is in development phase and specifications are subject to change without notice. Gennum reserves the right to remove the product at any time. Listing the product does not constitute an offer for sale.

PRELIMINARY DATA SHEET

The product is in a preproduction phase and specifications are subject to change without notice.

DATA SHEET

The product is in production. Gennum reserves the right to make changes at any time to improve reliability, function or design, in order to provide the best product possible.