

CS8190

Precision Air-Core Tach/Speedo Driver with Return to Zero

The CS8190 is specifically designed for use with air-core meter movements. The IC provides all the functions necessary for an analog tachometer or speedometer. The CS8190 takes a speed sensor input and generates sine and cosine related output signals to differentially drive an air-core meter.

Many enhancements have been added over industry standard tachometer drivers such as the CS289 or LM1819. The output utilizes differential drivers which eliminates the need for a zener reference and offers more torque. The device withstands 60 V transients which decreases the protection circuitry required. The device is also more precise than existing devices allowing for fewer trims and for use in a speedometer.

Features

- Direct Sensor Input
- High Output Torque
- Low Pointer Flutter
- High Input Impedance
- Overvoltage Protection
- Return to Zero
- Internally Fused Leads in PDIP-16 and SO-20W Packages
- These Devices are Pb-Free, Halogen Free/BFR Free and are RoHS Compliant



ON Semiconductor®

www.onsemi.com

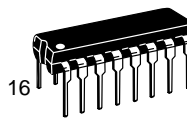

PDIP-16
NF SUFFIX
CASE 648

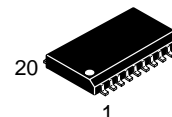

SO-20W
DWF SUFFIX
CASE 751D

PIN CONNECTIONS AND MARKING DIAGRAM

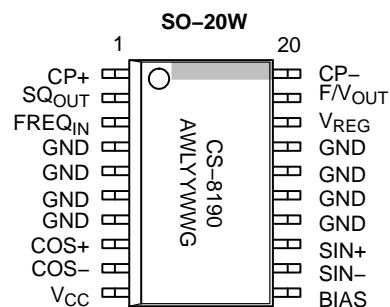
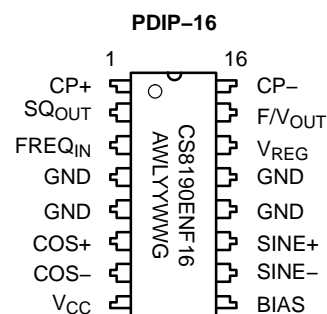

- A = Assembly Location
- WL = Wafer Lot
- YY = Year
- WW = Work Week
- G = Pb-Free Package

ORDERING INFORMATION

See detailed ordering and shipping information in the package dimensions section on page 10 of this data sheet.

CS8190

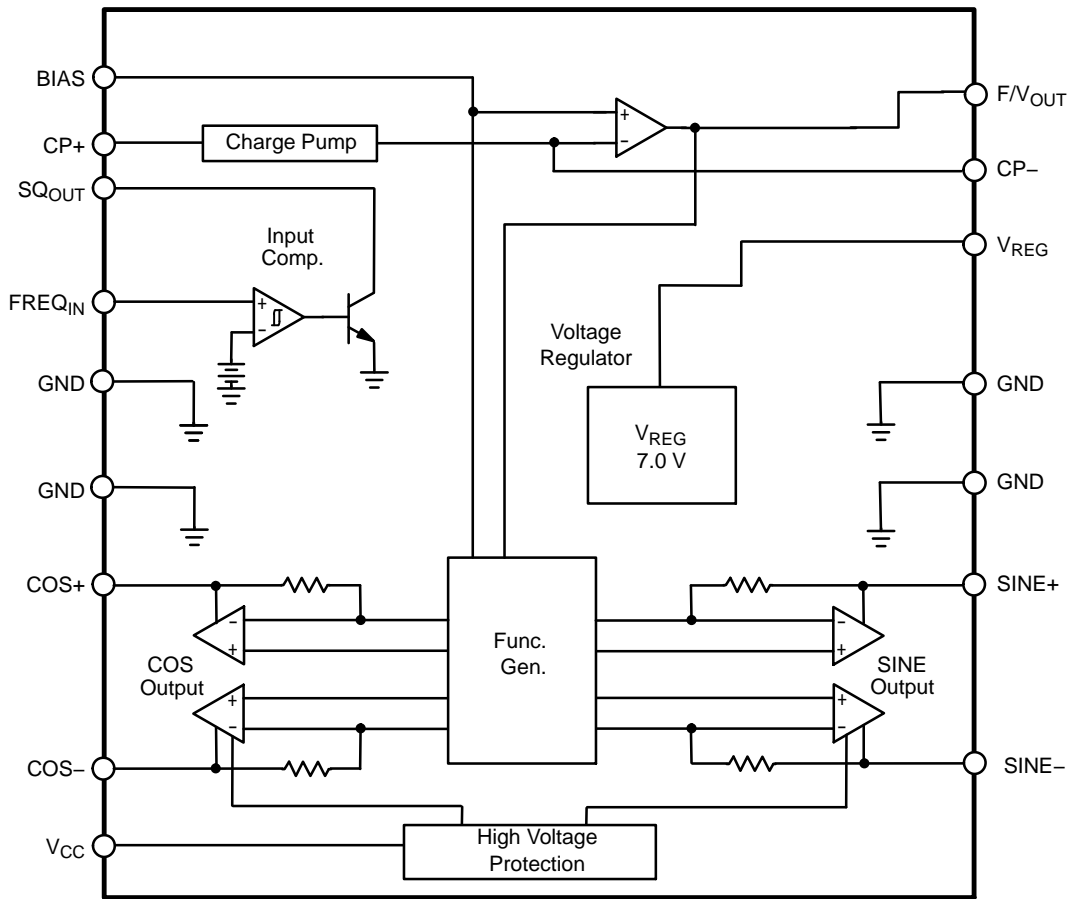

Figure 1. Block Diagram

ABSOLUTE MAXIMUM RATINGS

Rating	Value	Unit
Supply Voltage, V_{CC}	< 100 ms Pulse Transient 24 Continuous	V V
Operating Temperature	-40 to +105	°C
Storage Temperature	-40 to +165	°C
Junction Temperature	-40 to +150	°C
ESD (Human Body Model)	4.0	kV
Lead Temperature Soldering: Wave Solder (through hole styles only) (Note 1) Reflow: (SMD styles only) (Note 2)	260 peak 230 peak	°C °C

Stresses exceeding those listed in the Maximum Ratings table may damage the device. If any of these limits are exceeded, device functionality should not be assumed, damage may occur and reliability may be affected.

1. 10 seconds maximum.
2. 60 second maximum above 183°C.

CS8190

ELECTRICAL CHARACTERISTICS ($-40^{\circ}\text{C} \leq T_A \leq 85^{\circ}\text{C}$, $8.5\text{ V} \leq V_{CC} \leq 15\text{ V}$, unless otherwise specified.)

Characteristic	Test Conditions	Min	Typ	Max	Unit
----------------	-----------------	-----	-----	-----	------

SUPPLY VOLTAGE SECTION

I_{CC} Supply Current	$V_{CC} = 16\text{ V}$, -40°C , No Load	–	50	125	mA
V_{CC} Normal Operation Range	–	8.5	13.1	16	V

INPUT COMPARATOR SECTION

Positive Input Threshold	–	1.0	2.0	3.0	V
Input Hysteresis	–	200	500	–	mV
Input Bias Current (Note 3)	$0\text{ V} \leq V_{IN} \leq 8.0\text{ V}$	–	–10	–80	μA
Input Frequency Range	–	0	–	20	kHz
Input Voltage Range	in series with $1.0\text{ k}\Omega$	–1.0	–	V_{CC}	V
Output V_{SAT} (SQ_{OUT})	$I_{CC} = 10\text{ mA}$	–	0.15	0.40	V
Output Leakage (SQ_{OUT})	$V_{CC} = 7.0\text{ V}$	–	–	10	μA
Low V_{CC} Disable Threshold	–	7.0	8.0	8.5	V
Logic 0 Input Voltage	–	1.0	–	–	V

VOLTAGE REGULATOR SECTION

Output Voltage	–	6.25	7.00	7.50	V
Output Load Current	–	–	–	10	mA
Output Load Regulation	0 to 10 mA	–	10	50	mV
Output Line Regulation	$8.5\text{ V} \leq V_{CC} \leq 16\text{ V}$	–	20	150	mV
Power Supply Rejection	$V_{CC} = 13.1\text{ V}$, $1.0\text{ V}_{P/P}$, 1.0 kHz	34	46	–	dB

CHARGE PUMP SECTION

Inverting Input Voltage	–	1.5	2.0	2.5	V
Input Bias Current	–	–	40	150	nA
V_{BIAS} Input Voltage	–	1.5	2.0	2.5	V
Non Invert. Input Voltage	$I_{IN} = 1.0\text{ mA}$	–	0.7	1.1	V
Linearity (Note 4)	@ 0, 87.5, 175, 262.5, + 350 Hz	–0.10	0.28	+0.70	%
F/ V_{OUT} Gain	@ 350 Hz, $C_{CP} = 0.0033\text{ }\mu\text{F}$, $R_T = 243\text{ k}\Omega$	7.0	10	13	mV/Hz
Norton Gain, Positive	$I_{IN} = 15\text{ }\mu\text{A}$	0.9	1.0	1.1	I/I
Norton Gain, Negative	$I_{IN} = 15\text{ }\mu\text{A}$	0.9	1.0	1.1	I/I

FUNCTION GENERATOR SECTION: $-40^{\circ}\text{C} \leq T_A \leq 85^{\circ}\text{C}$, $V_{CC} = 13.1\text{ V}$ unless otherwise noted

Return to Zero Threshold	$T_A = 25^{\circ}\text{C}$	5.2	6.0	7.0	V
Differential Drive Voltage, ($V_{COS+} - V_{COS-}$)	$8.5\text{ V} \leq V_{CC} \leq 16\text{ V}$, $\theta = 0^{\circ}$	5.5	6.5	7.5	V
Differential Drive Voltage, ($V_{SIN+} - V_{SIN-}$)	$8.5\text{ V} \leq V_{CC} \leq 16\text{ V}$, $\theta = 90^{\circ}$	5.5	6.5	7.5	V
Differential Drive Voltage, ($V_{COS+} - V_{COS-}$)	$8.5\text{ V} \leq V_{CC} \leq 16\text{ V}$, $\theta = 180^{\circ}$	–7.5	–6.5	–5.5	V
Differential Drive Voltage, ($V_{SIN+} - V_{SIN-}$)	$8.5\text{ V} \leq V_{CC} \leq 16\text{ V}$, $\theta = 270^{\circ}$	–7.5	–6.5	–5.5	V
Differential Drive Current	$8.5\text{ V} \leq V_{CC} \leq 16\text{ V}$	–	33	42	mA
Zero Hertz Output Angle	–	–1.5	0	1.5	deg

3. Input is clamped by an internal 12 V Zener.

4. Applies to % of full scale (270°).

CS8190

ELECTRICAL CHARACTERISTICS ($-40^{\circ}\text{C} \leq T_A \leq 85^{\circ}\text{C}$, $8.5\text{ V} \leq V_{CC} \leq 15\text{ V}$, unless otherwise specified.)

Characteristic	Test Conditions	Min	Typ	Max	Unit
----------------	-----------------	-----	-----	-----	------

FUNCTION GENERATOR SECTION: $-40^{\circ}\text{C} \leq T_A \leq 85^{\circ}\text{C}$, $V_{CC} = 13.1\text{ V}$ unless otherwise noted (continued)

Function Generator Error (Note 5) Reference Figures 2, 3, 4, 5	$V_{CC} = 13.1\text{ V}$ $\theta = 0^{\circ}$ to 305°	-2.0	0	+2.0	deg
Function Generator Error	$13.1\text{ V} \leq V_{CC} \leq 16\text{ V}$	-2.5	0	+2.5	deg
Function Generator Error	$13.1\text{ V} \leq V_{CC} \leq 11\text{ V}$	-1.0	0	+1.0	deg
Function Generator Error	$13.1\text{ V} \leq V_{CC} \leq 9.0\text{ V}$	-3.0	0	+3.0	deg
Function Generator Error	$25^{\circ}\text{C} \leq T_A \leq 80^{\circ}\text{C}$	-3.0	0	+3.0	deg
Function Generator Error	$25^{\circ}\text{C} \leq T_A \leq 105^{\circ}\text{C}$	-5.5	0	+5.5	deg
Function Generator Error	$-40^{\circ}\text{C} \leq T_A \leq 25^{\circ}\text{C}$	-3.0	0	+3.0	deg
Function Generator Gain	$T_A = 25^{\circ}\text{C}$, θ vs F/V_{OUT}	60	77	95	$^{\circ}/V$

5. Deviation from nominal per Table 1 after calibration at 0° and 270° .

PIN FUNCTION DESCRIPTION

PACKAGE PIN #		PIN SYMBOL	FUNCTION
PDIP-16	SO-20W		
1	1	CP+	Positive input to charge pump.
2	2	SQ _{OUT}	Buffered square wave output signal.
3	3	FREQ _{IN}	Speed or RPM input signal.
4, 5, 12, 13	4-7, 14-17	GND	Ground Connections.
6	8	COS+	Positive cosine output signal.
7	9	COS-	Negative cosine output signal.
8	10	V _{CC}	Ignition or battery supply voltage.
9	11	BIAS	Test point or zero adjustment.
10	12	SIN-	Negative sine output signal.
11	13	SIN+	Positive sine output signal.
14	18	V _{REG}	Voltage regulator output.
15	19	F/V _{OUT}	Output voltage proportional to input signal frequency.
16	20	CP-	Negative input to charge pump.

TYPICAL PERFORMANCE CHARACTERISTICS

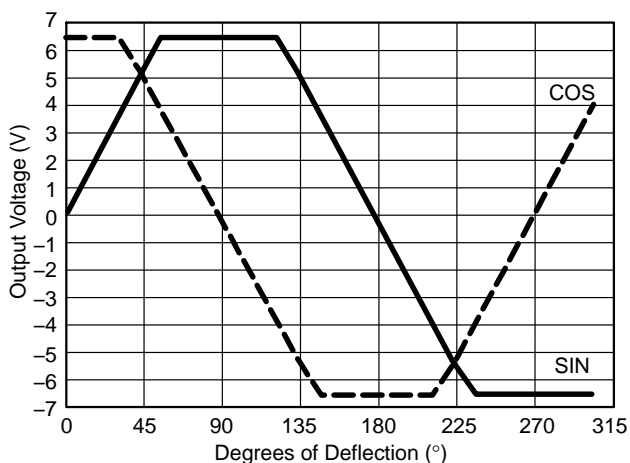

Figure 2. Function Generator Output Voltage vs. Degrees of Deflection

$$F/V_{OUT} = 2.0 V + 2.0 \times \text{FREQ} \times C_{CP} \times R_T \times (V_{REG} - 0.7 V)$$

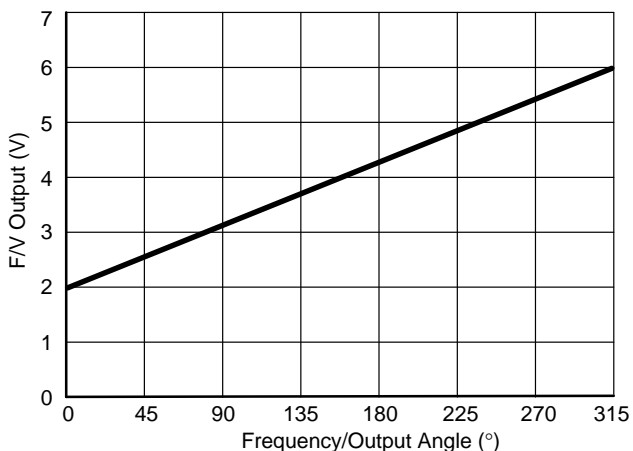

Figure 3. Charge Pump Output Voltage vs. Output Angle

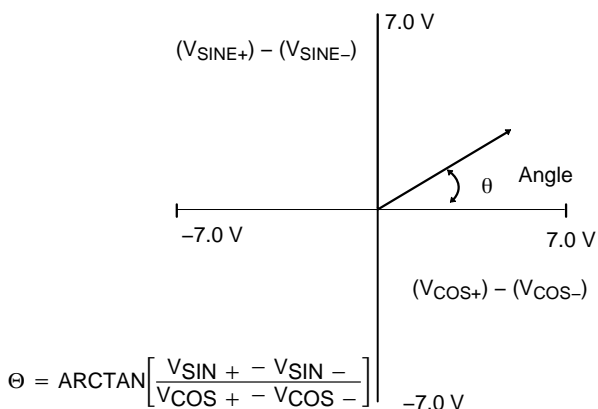

Figure 4. Output Angle in Polar Form

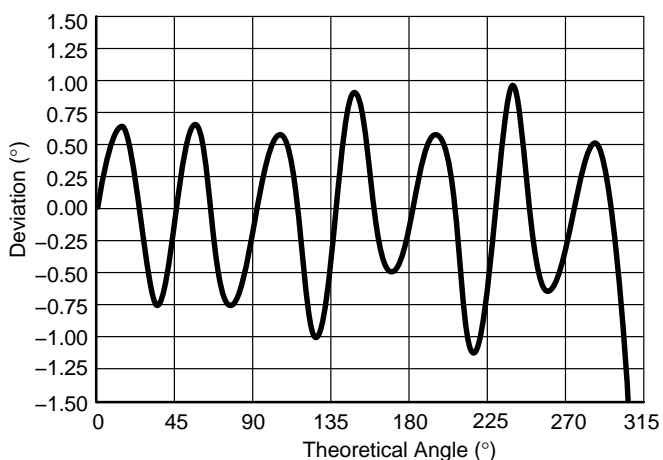

Figure 5. Nominal Output Deviation

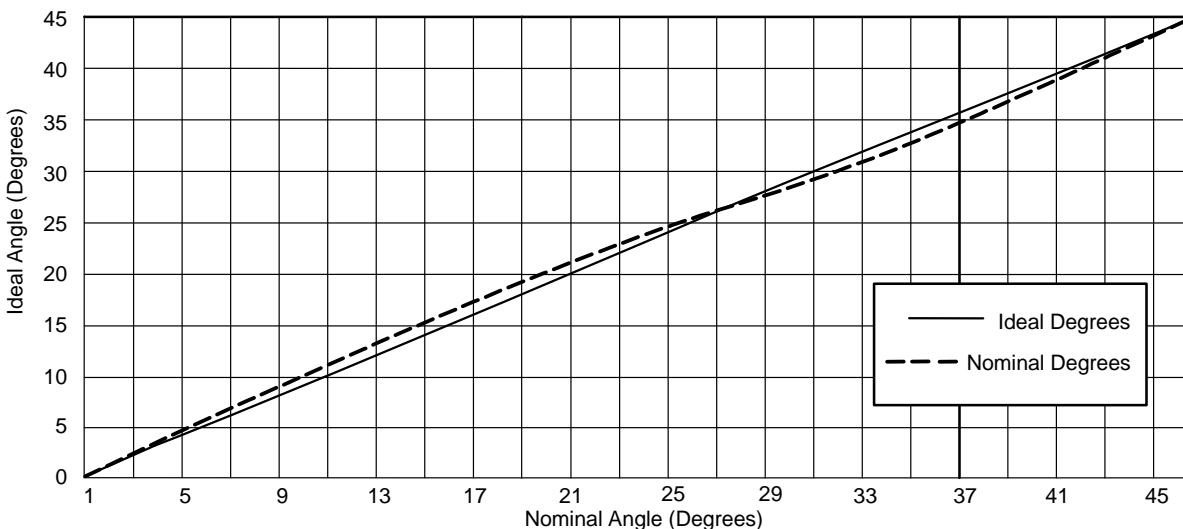

Figure 6. Nominal Angle vs. Ideal Angle (After Calibrating at 180°)

Table 1. Function Generator Output Nominal Angle vs. Ideal Angle (After Calibrating at 270°)

Ideal θ Degrees	Nominal θ Degrees	Ideal θ Degrees	Nominal θ Degrees	Ideal θ Degrees	Nominal θ Degrees	Ideal θ Degrees	Nominal θ Degrees	Ideal θ Degrees	Nominal θ Degrees	Ideal θ Degrees	Nominal θ Degrees
0	0	17	17.98	34	33.04	75	74.00	160	159.14	245	244.63
1	1.09	18	18.96	35	34.00	80	79.16	165	164.00	250	249.14
2	2.19	19	19.92	36	35.00	85	84.53	170	169.16	255	254.00
3	3.29	20	20.86	37	36.04	90	90.00	175	174.33	260	259.16
4	4.38	21	21.79	38	37.11	95	95.47	180	180.00	265	264.53
5	5.47	22	22.71	39	38.21	100	100.84	185	185.47	270	270.00
6	6.56	23	23.61	40	39.32	105	106.00	190	190.84	275	275.47
7	7.64	24	24.50	41	40.45	110	110.86	195	196.00	280	280.84
8	8.72	25	25.37	42	41.59	115	115.37	200	200.86	285	286.00
9	9.78	26	26.23	43	42.73	120	119.56	205	205.37	290	290.86
10	10.84	27	27.07	44	43.88	125	124.00	210	209.56	295	295.37
11	11.90	28	27.79	45	45.00	130	129.32	215	214.00	300	299.21
12	12.94	29	28.73	50	50.68	135	135.00	220	219.32	305	303.02
13	13.97	30	29.56	55	56.00	140	140.68	225	225.00		
14	14.99	31	30.39	60	60.44	145	146.00	230	230.58		
15	16.00	32	31.24	65	64.63	150	150.44	235	236.00		
16	17.00	33	32.12	70	69.14	155	154.63	240	240.44		

Note: Temperature, voltage and nonlinearity not included.

CIRCUIT DESCRIPTION and APPLICATION NOTES

The CS8190 is specifically designed for use with air-core meter movements. It includes an input comparator for sensing an input signal from an ignition pulse or speed sensor, a charge pump for frequency to voltage conversion, a bandgap voltage regulator for stable operation, and a function generator with sine and cosine amplifiers to differentially drive the meter coils.

From the partial schematic of Figure 7, the input signal is applied to the $FREQ_{IN}$ lead, this is the input to a high impedance comparator with a typical positive input threshold of 2.0 V and typical hysteresis of 0.5 V. The output of the comparator, SQ_{OUT} , is applied to the charge pump input $CP+$ through an external capacitor C_{CP} . When the input signal changes state, C_{CP} is charged or discharged through R3 and R4. The charge accumulated on C_{CP} is mirrored to C4 by the Norton Amplifier circuit comprising of Q1, Q2 and Q3. The charge pump output voltage, F/V_{OUT} , ranges from 2.0 V to 6.3 V depending on the input signal frequency and the gain of the charge pump according to the formula:

$$F/V_{OUT} = 2.0 V + 2.0 \times FREQ \times C_{CP} \times R_T \times (V_{REG} - 0.7 V)$$

R_T is a potentiometer used to adjust the gain of the F/V output stage and give the correct meter deflection. The F/V output voltage is applied to the function generator which generates the sine and cosine output voltages. The output voltage of the sine and cosine amplifiers are derived from the

on-chip amplifier and function generator circuitry. The various trip points for the circuit (i.e., 0°, 90°, 180°, 270°) are determined by an internal resistor divider and the bandgap voltage reference. The coils are differentially driven, allowing bidirectional current flow in the outputs, thus providing up to 305° range of meter deflection. Driving the coils differentially offers faster response time, higher current capability, higher output voltage swings, and reduced external component count. The key advantage is a higher torque output for the pointer.

The output angle, θ , is equal to the F/V gain multiplied by the function generator gain:

$$\theta = AF/V \times AFG,$$

where:

$$AFG = 77^\circ /V(\text{typ})$$

The relationship between input frequency and output angle is:

$$\theta = AFG \times 2.0 \times FREQ \times C_{CP} \times R_T \times (V_{REG} - 0.7 V)$$

or,

$$\theta = 970 \times FREQ \times C_{CP} \times R_T$$

The ripple voltage at the F/V converter's output is determined by the ratio of C_{CP} and C4 in the formula:

$$\Delta V = \frac{C_{CP}(V_{REG} - 0.7 V)}{C4}$$

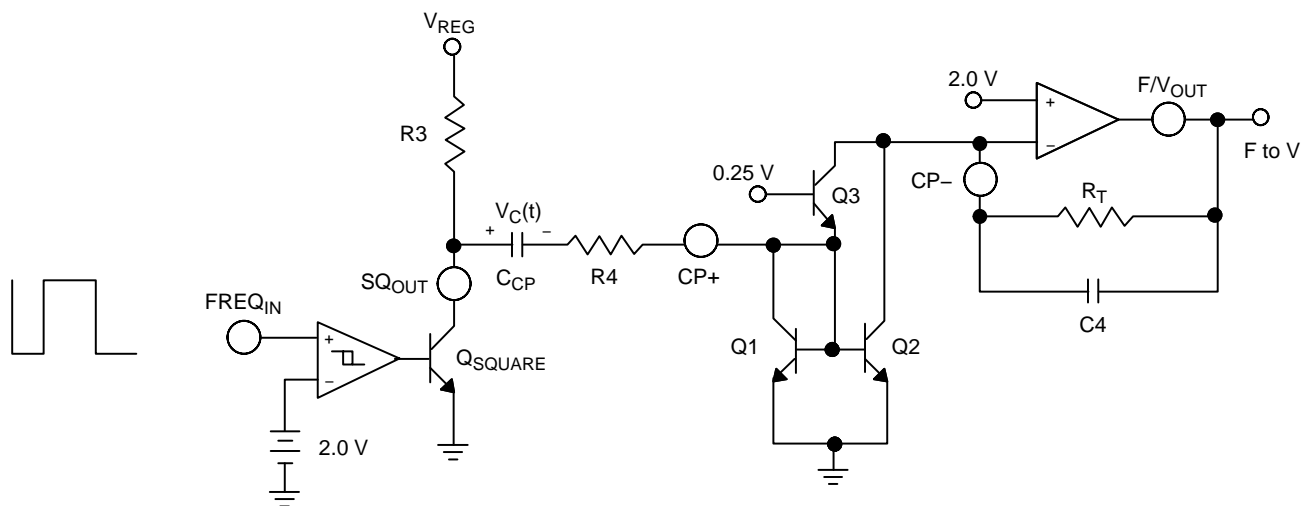

Figure 7. Partial Schematic of Input and Charge Pump

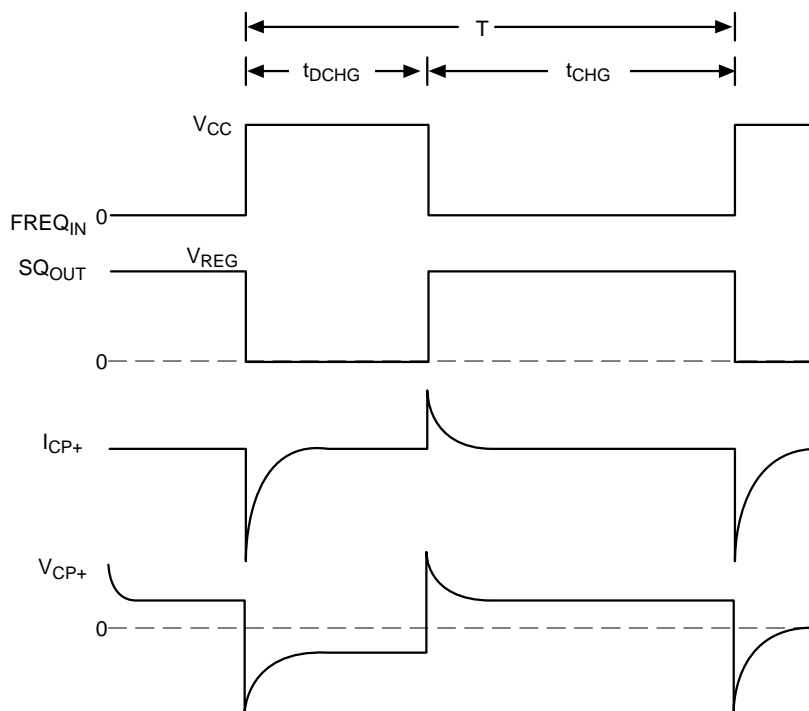

Figure 8. Timing Diagram of FREQ_IN and I_CP

Ripple voltage on the F/V output causes pointer or needle flutter especially at low input frequencies.

The response time of the F/V is determined by the time constant formed by R_T and C_4 . Increasing the value of C_4 will reduce the ripple on the F/V output but will also increase the response time. An increase in response time causes a very slow meter movement and may be unacceptable for many applications.

The CS8190 has an undervoltage detect circuit that disables the input comparator when V_{CC} falls below 8.0 V (typical). With no input signal the F/V output voltage decreases and the needle moves towards zero. A second undervoltage detect circuit at 6.0 V (typical) causes the function generator to

generate a differential SIN drive voltage of zero volts and the differential COS drive voltage to go as high as possible. This combination of voltages (Figure 2) across the meter coil moves the needle to the 0° position. Connecting a large capacitor ($> 2000 \mu\text{F}$) to the V_{CC} lead (C_2 in Figure 9) increases the time between these undervoltage points since the capacitor discharges slowly and ensures that the needle moves towards 0° as opposed to 360° . The exact value of the capacitor depends on the response time of the system, the maximum meter deflection and the current consumption of the circuit. It should be selected by breadboarding the design in the lab.

CS8190

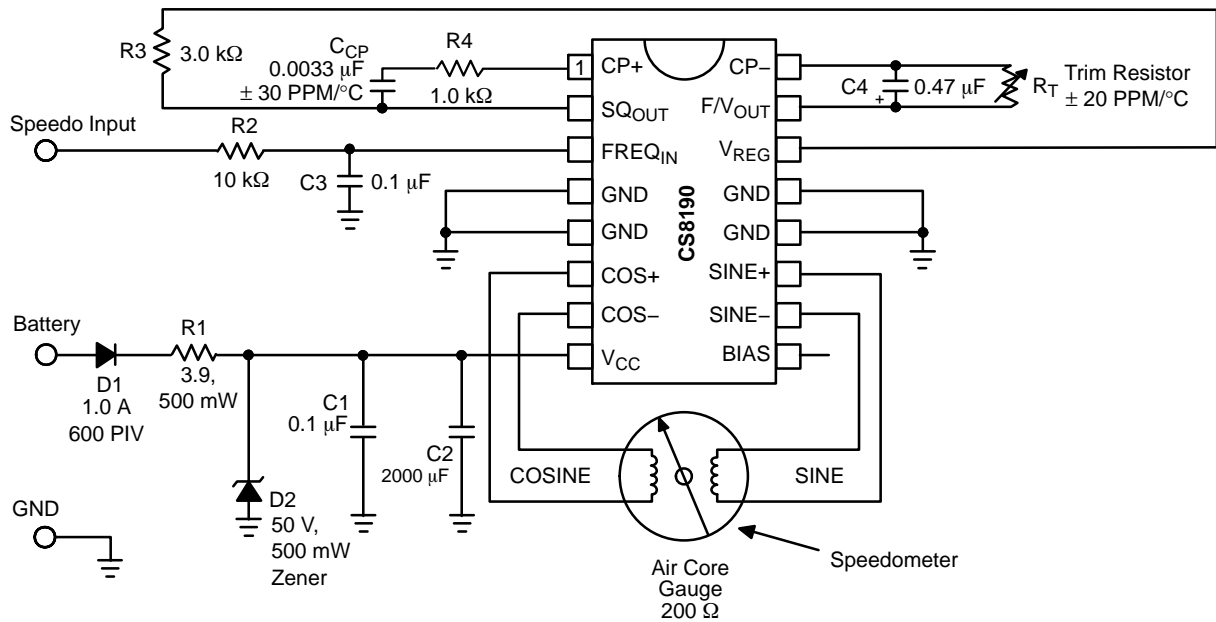

Notes:

1. C2 (> 2000 μ F) is needed if return to zero function is required.
2. The product of C_{CP} and R_T have a direct effect on the transfer function (f to V conversion) and therefore directly affect temperature compensation.
3. C_{CP} Range; 20 pF to 0.2 μ F.
4. R_T Range; 100 k Ω to 500 k Ω .
5. The IC must be protected from transients above 60 V and reverse battery conditions.
6. Additional filtering on the FREQ_{IN} lead may be required.
7. Gauge coil connections to the IC must be kept as short as possible (\leq 3.0 inch) for best pointer stability.

Figure 9. Speedometer or Tachometer Application

Design Example

Maximum meter Deflection = 270°

Maximum Input Frequency = 350 Hz

1. Select R_T and C_{CP}

$$\theta = 970 \times \text{FREQ} \times C_{CP} \times R_T = 270^\circ$$

Let C_{CP} = 0.0033 μ F, find R_T

$$R_T = \frac{270^\circ}{970 \times 350 \text{ Hz} \times 0.0033 \mu\text{F}}$$

$$R_T = 243 \text{ k}\Omega$$

R_T should be a 250 k Ω potentiometer to trim out any inaccuracies due to IC tolerances or meter movement pointer placement.

2. Select R3 and R4

Resistor R3 sets the output current from the voltage regulator. The maximum output current from the voltage regulator is 10 mA. R3 must ensure that the current does not exceed this limit.

Choose R3 = 3.3 k Ω

The maximum charge current for C_{CP} is worst case estimated at:

$$\frac{V_{REG} - 0.7 \text{ V}}{3.3 \text{ k}\Omega} = 1.90 \text{ mA}$$

C_{CP} must charge and discharge fully during each cycle of the input signal. Time for one cycle at maximum frequency

is 2.85 ms. To ensure that C_{CP} is charged, assume that the (R3 + R4) C_{CP} time constant is less than 10% of the minimum input period.

$$T = 10\% \times \frac{1}{350 \text{ Hz}} = 285 \mu\text{s}$$

Choose R4 = 1.0 k Ω .

Discharge time: $t_{DCHG} = R4 \times C_{CP} = 3.3 \text{ k}\Omega \times 0.0033 \mu\text{F} = 3.3 \mu\text{s}$

Charge time: $t_{CHG} = (R3 + R4)C_{CP} = 4.3 \text{ k}\Omega \times 0.0033 \mu\text{F} = 14.2 \mu\text{s}$

3. Determine C4

C4 is selected to satisfy both the maximum allowable ripple voltage and response time of the meter movement.

$$C4 = \frac{C_{CP}(V_{REG} - 0.7 \text{ V})}{\Delta V_{MAX}}$$

With C4 = 0.47 μ F, the F/V ripple voltage is 44 mV.

The last component to be selected is the return to zero capacitor C2. This is selected by increasing the input signal frequency to its maximum so the pointer is at its maximum deflection, then removing the power from the circuit. C2 should be large enough to ensure that the pointer always returns to the 0° position rather than 360° under all operating conditions.

Figure 10 shows how the CS8190 and the CS8441 are used to produce a Speedometer and Odometer circuit.

CS8190

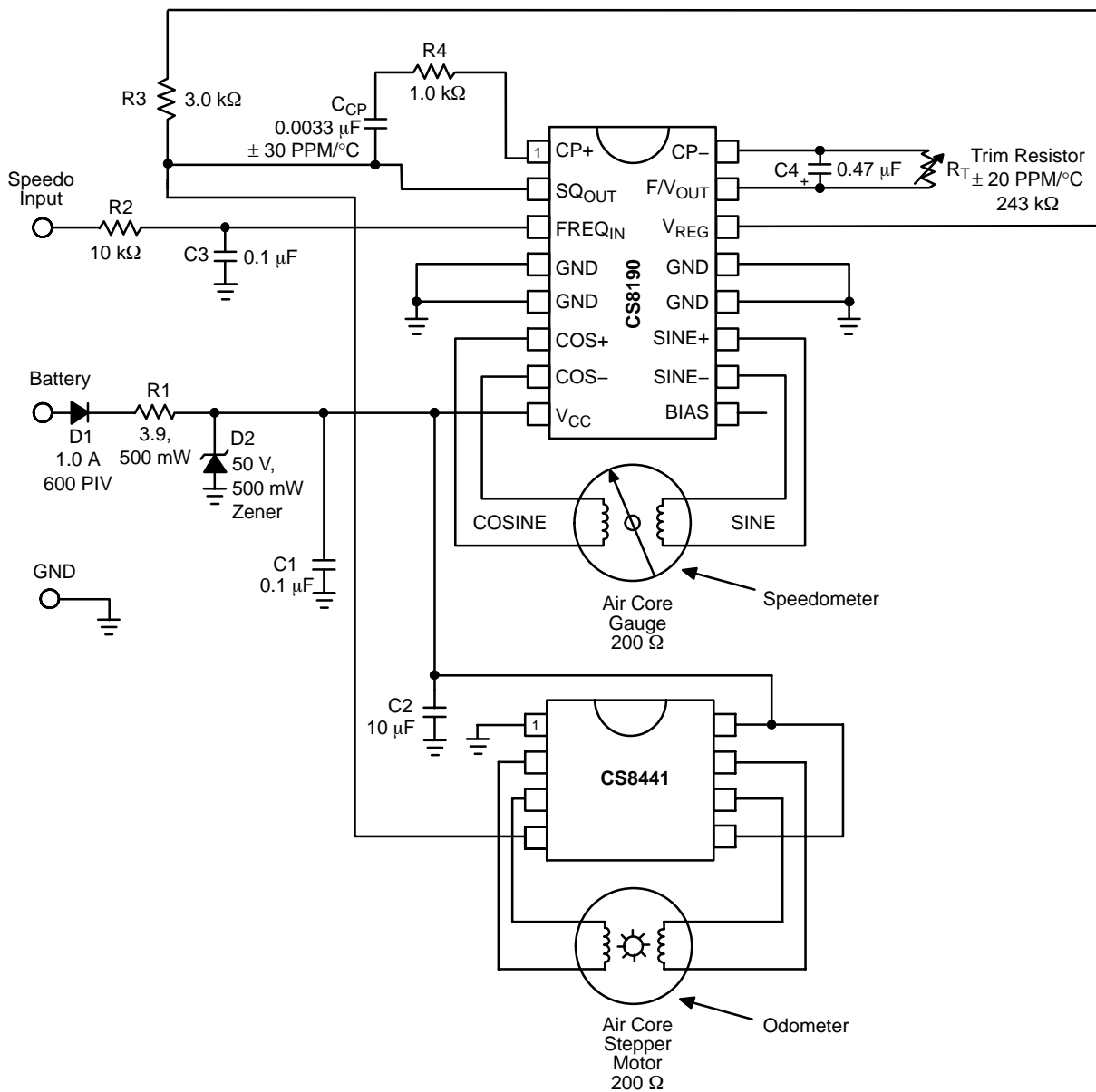

Notes:

1. C₂ = 10 μF with CS8441 application.
2. The product of C_{CP} and R_T have a direct effect on the transfer function (f to V conversion) and therefore directly affect temperature compensation.
3. C_{CP} Range; 20 pF to 0.2 μF.
4. R_T Range; 100 kΩ to 500 kΩ.
5. The IC must be protected from transients above 60 V and reverse battery conditions.
6. Additional filtering on the FREQ_{IN} lead may be required.
7. Gauge coil connections to the IC must be kept as short as possible (≤ 3.0 inch) for best pointer stability.

Figure 10. Speedometer With Odometer or Tachometer Application

CS8190

In some cases a designer may wish to use the CS8190 only as a driver for an air-core meter having performed the F/V conversion elsewhere in the circuit.

Figure 11 shows how to drive the CS8190 with a DC voltage ranging from 2.0 V to 6.0 V. This is accomplished by forcing a voltage on the F/V_{OUT} lead. The alternative scheme shown in Figure 12 uses an external op amp as a buffer and operates over an input voltage range of 0 V to 4.0 V.

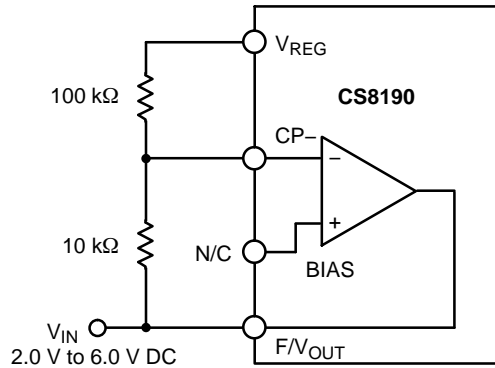

Figure 11. Driving the CS8190 from an External DC Voltage

Figures 11 and 12 are not temperature compensated.

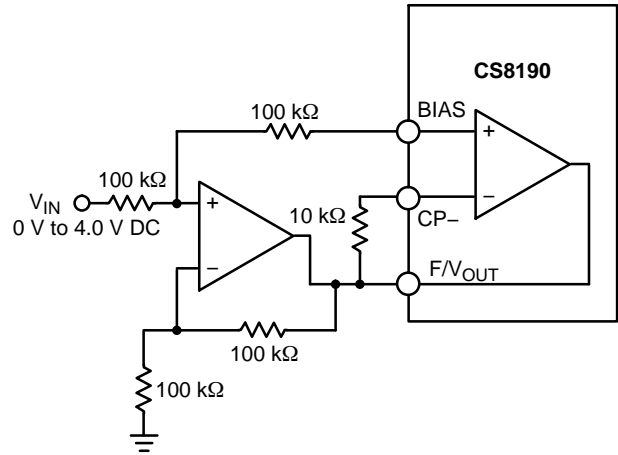

Figure 12. Driving the CS8190 from an External DC Voltage Using an Op Amp Buffer

PACKAGE THERMAL DATA

Parameter		PDIP-16	SO-20W	Unit
R _{θJC}	Typical	15	9	°C/W
R _{θJA}	Typical	50	55	°C/W

ORDERING INFORMATION

Device	Package	Shipping†
CS8190ENF16G	PDIP-16 (Pb-Free)	
CS8190EDWF20G	SO-20W (Pb-Free)	
CS8190EDWFR20G	SO-20W (Pb-Free)	

†For information on tape and reel specifications, including part orientation and tape sizes, please refer to our Tape and Reel Packaging Specifications Brochure, BRD8011/D.

MECHANICAL CASE OUTLINE

PACKAGE DIMENSIONS

ON Semiconductor®

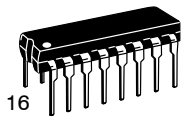

PDIP-16
CASE 648-08
ISSUE V

DATE 22 APR 2015

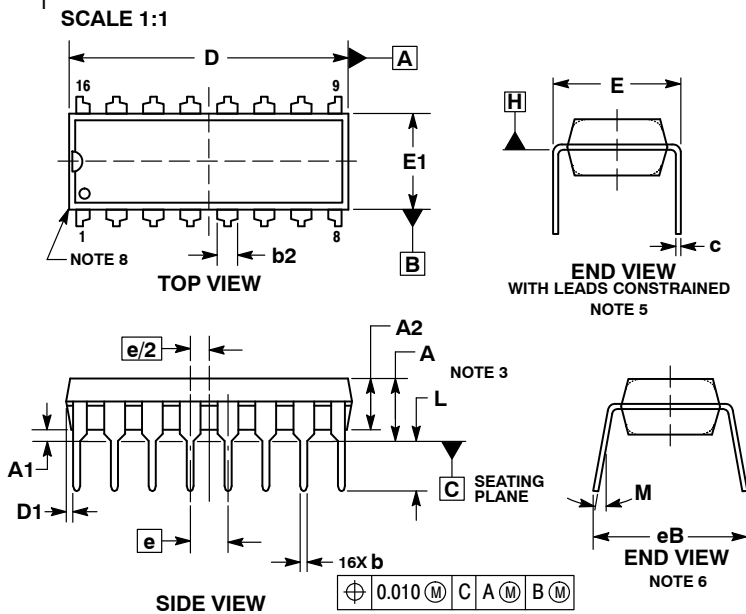

NOTES:

1. DIMENSIONING AND TOLERANCING PER ASME Y14.5M, 1994.
2. CONTROLLING DIMENSION: INCHES.
3. DIMENSIONS A, A1 AND L ARE MEASURED WITH THE PACKAGE SEATED IN JEDEC SEATING PLANE GAUGE GS-3.
4. DIMENSIONS D, D1 AND E1 DO NOT INCLUDE MOLD FLASH OR PROTRUSIONS. MOLD FLASH OR PROTRUSIONS ARE NOT TO EXCEED 0.10 INCH.
5. DIMENSION E IS MEASURED AT A POINT 0.015 BELOW DATUM PLANE H WITH THE LEADS CONSTRAINED PERPENDICULAR TO DATUM C.
6. DIMENSION eB IS MEASURED AT THE LEAD TIPS WITH THE LEADS UNCONSTRAINED.
7. DATUM PLANE H IS COINCIDENT WITH THE BOTTOM OF THE LEADS, WHERE THE LEADS EXIT THE BODY.
8. PACKAGE CONTOUR IS OPTIONAL (ROUNDED OR SQUARE CORNERS).

DIM	INCHES		MILLIMETERS	
	MIN	MAX	MIN	MAX
A	---	0.210	---	5.33
A1	0.015	---	0.38	---
A2	0.115	0.195	2.92	4.95
b	0.014	0.022	0.35	0.56
b2	0.060 TYP		1.52 TYP	
C	0.008	0.014	0.20	0.36
D	0.735	0.775	18.67	19.69
D1	0.005	---	0.13	---
E	0.300	0.325	7.62	8.26
E1	0.240	0.280	6.10	7.11
e	0.100 BSC		2.54 BSC	
eB	---	0.430	---	10.92
L	0.115	0.150	2.92	3.81
M	---	10°	---	10°

GENERIC MARKING DIAGRAM*

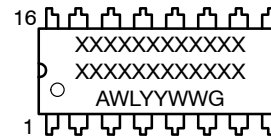

- XXXXX = Specific Device Code
- A = Assembly Location
- WL = Wafer Lot
- YY = Year
- WW = Work Week
- G = Pb-Free Package

*This information is generic. Please refer to device data sheet for actual part marking. Pb-Free indicator, "G" or microdot "▪", may or may not be present.

STYLE 1:

- PIN 1. CATHODE
- 2. CATHODE
- 3. CATHODE
- 4. CATHODE
- 5. CATHODE
- 6. CATHODE
- 7. CATHODE
- 8. CATHODE
- 9. ANODE
- 10. ANODE
- 11. ANODE
- 12. ANODE
- 13. ANODE
- 14. ANODE
- 15. ANODE
- 16. ANODE

STYLE 2:

- PIN 1. COMMON DRAIN
- 2. COMMON DRAIN
- 3. COMMON DRAIN
- 4. COMMON DRAIN
- 5. COMMON DRAIN
- 6. COMMON DRAIN
- 7. COMMON DRAIN
- 8. COMMON DRAIN
- 9. GATE
- 10. SOURCE
- 11. GATE
- 12. SOURCE
- 13. GATE
- 14. SOURCE
- 15. GATE
- 16. SOURCE

DOCUMENT NUMBER:	98ASB42431B	Electronic versions are uncontrolled except when accessed directly from the Document Repository. Printed versions are uncontrolled except when stamped "CONTROLLED COPY" in red.
DESCRIPTION:	PDIP-16	PAGE 1 OF 1

ON Semiconductor and ON are trademarks of Semiconductor Components Industries, LLC dba ON Semiconductor or its subsidiaries in the United States and/or other countries. ON Semiconductor reserves the right to make changes without further notice to any products herein. ON Semiconductor makes no warranty, representation or guarantee regarding the suitability of its products for any particular purpose, nor does ON Semiconductor assume any liability arising out of the application or use of any product or circuit, and specifically disclaims any and all liability, including without limitation special, consequential or incidental damages. ON Semiconductor does not convey any license under its patent rights nor the rights of others.

MECHANICAL CASE OUTLINE PACKAGE DIMENSIONS

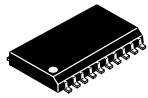

SCALE 1:1

SOIC-20 WB
CASE 751D-05
ISSUE H

DATE 22 APR 2015

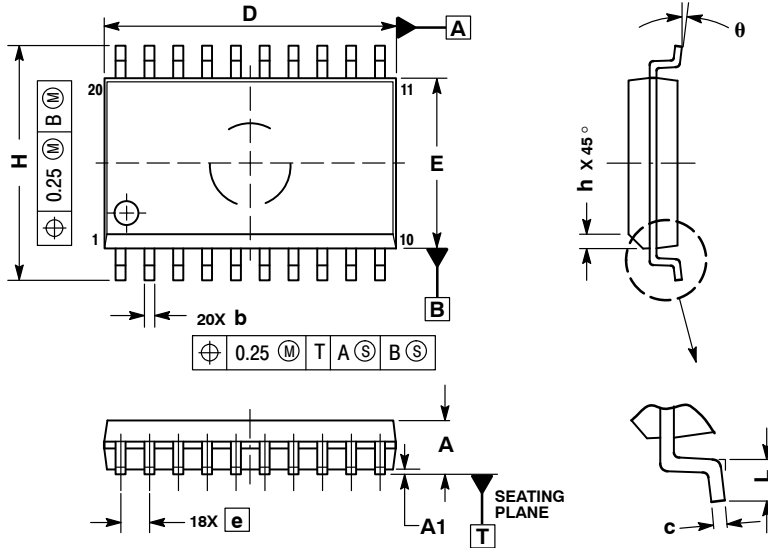

NOTES:

1. DIMENSIONS ARE IN MILLIMETERS.
2. INTERPRET DIMENSIONS AND TOLERANCES PER ASME Y14.5M, 1994.
3. DIMENSIONS D AND E DO NOT INCLUDE MOLD PROTRUSION.
4. MAXIMUM MOLD PROTRUSION 0.15 PER SIDE.
5. DIMENSION B DOES NOT INCLUDE DAMBAR PROTRUSION. ALLOWABLE PROTRUSION SHALL BE 0.13 TOTAL IN EXCESS OF B DIMENSION AT MAXIMUM MATERIAL CONDITION.

DIM	MILLIMETERS	
	MIN	MAX
A	2.35	2.65
A1	0.10	0.25
b	0.35	0.49
c	0.23	0.32
D	12.65	12.95
E	7.40	7.60
e	1.27 BSC	
H	10.05	10.55
h	0.25	0.75
L	0.50	0.90
θ	0°	7°

RECOMMENDED
SOLDERING FOOTPRINT*

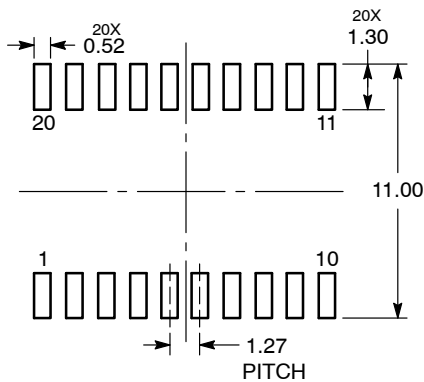

DIMENSIONS: MILLIMETERS

*For additional information on our Pb-Free strategy and soldering details, please download the ON Semiconductor Soldering and Mounting Techniques Reference Manual, SOLDERRM/D.

GENERIC
MARKING DIAGRAM*

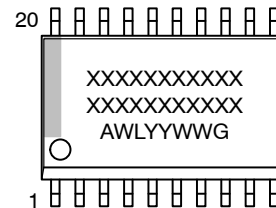

- XXXXXX = Specific Device Code
- A = Assembly Location
- WL = Wafer Lot
- YY = Year
- WW = Work Week
- G = Pb-Free Package

*This information is generic. Please refer to device data sheet for actual part marking. Pb-Free indicator, "G" or microdot "▪", may or may not be present. Some products may not follow the Generic Marking.

DOCUMENT NUMBER:	98ASB42343B	Electronic versions are uncontrolled except when accessed directly from the Document Repository. Printed versions are uncontrolled except when stamped "CONTROLLED COPY" in red.
DESCRIPTION:	SOIC-20 WB	PAGE 1 OF 1

onsemi and ONSEMI are trademarks of Semiconductor Components Industries, LLC dba onsemi or its subsidiaries in the United States and/or other countries. onsemi reserves the right to make changes without further notice to any products herein. onsemi makes no warranty, representation or guarantee regarding the suitability of its products for any particular purpose, nor does onsemi assume any liability arising out of the application or use of any product or circuit, and specifically disclaims any and all liability, including without limitation special, consequential or incidental damages. onsemi does not convey any license under its patent rights nor the rights of others.

onsemi, **Onsemi**, and other names, marks, and brands are registered and/or common law trademarks of Semiconductor Components Industries, LLC dba "**onsemi**" or its affiliates and/or subsidiaries in the United States and/or other countries. **onsemi** owns the rights to a number of patents, trademarks, copyrights, trade secrets, and other intellectual property. A listing of **onsemi**'s product/patent coverage may be accessed at www.onsemi.com/site/pdf/Patent-Marking.pdf. **onsemi** reserves the right to make changes at any time to any products or information herein, without notice. The information herein is provided "as-is" and **onsemi** makes no warranty, representation or guarantee regarding the accuracy of the information, product features, availability, functionality, or suitability of its products for any particular purpose, nor does **onsemi** assume any liability arising out of the application or use of any product or circuit, and specifically disclaims any and all liability, including without limitation special, consequential or incidental damages. Buyer is responsible for its products and applications using **onsemi** products, including compliance with all laws, regulations and safety requirements or standards, regardless of any support or applications information provided by **onsemi**. "Typical" parameters which may be provided in **onsemi** data sheets and/or specifications can and do vary in different applications and actual performance may vary over time. All operating parameters, including "Typicals" must be validated for each customer application by customer's technical experts. **onsemi** does not convey any license under any of its intellectual property rights nor the rights of others. **onsemi** products are not designed, intended, or authorized for use as a critical component in life support systems or any FDA Class 3 medical devices or medical devices with a same or similar classification in a foreign jurisdiction or any devices intended for implantation in the human body. Should Buyer purchase or use **onsemi** products for any such unintended or unauthorized application, Buyer shall indemnify and hold **onsemi** and its officers, employees, subsidiaries, affiliates, and distributors harmless against all claims, costs, damages, and expenses, and reasonable attorney fees arising out of, directly or indirectly, any claim of personal injury or death associated with such unintended or unauthorized use, even if such claim alleges that **onsemi** was negligent regarding the design or manufacture of the part. **onsemi** is an Equal Opportunity/Affirmative Action Employer. This literature is subject to all applicable copyright laws and is not for resale in any manner.

ADDITIONAL INFORMATION

TECHNICAL PUBLICATIONS:

Technical Library: www.onsemi.com/design/resources/technical-documentation
onsemi Website: www.onsemi.com

ONLINE SUPPORT: www.onsemi.com/support

For additional information, please contact your local Sales Representative at www.onsemi.com/support/sales