

Features

HIGH CURRENT CARRY AND HIGH VOLTAGE

Inert gas filled arc chamber suitable for high voltage switching

COMPACT STRUCTURE, LOW NOISE

Small, low-profile design with low noise while carrying or switching loads

SAFE FOR EXPLOSIVE ENVIRONMENTS

No arc leakage due to a hermetically sealed design

HIGH RELIABILITY DESIGN

Hermetic sealing creates a stable environment for high voltage switching

NO SPECIFIC MOUNTING ARRANGEMENT

Mountable in any orientation without reduction of performance

VARIOUS APPLICATIONS

Pre-charge contactor, battery disconnect, EV charging, energy storage systems, photovoltaics, power control, circuit protection and much more

Sealing Type: Epoxy

- ✓ Quick connect tabs or PCB mount



Certification Information

1. Meet RoHS (2011/65/EU)
2. CE certified

Nomenclature

AEV20E

B

-

Series code:
"AEV20E" = AEV20E

Coil Voltage Code:
"B" = 12VDC
"C" = 24VDC

Blank = Std.Options (Bottom Mount, Quick Connect Terminals)
"P" = PCB Terminals (no mounting tabs)

Product Data Sheet

MAIN CONTACT

Contact Arrangement	1 Form X (SPST-NO)	
Rated Operating Voltage	750 VDC	
Rated current	20A	
Short Term Current	30A (1h)	
Dielectric Withstanding Voltage (initial)	Between Open Contacts	2500 VAC 1mA 1min
	Between Contacts to Coil	3000 VAC 1mA 1min
Insulation Resistance (initial)	Terminal to Terminal	Min. 1000 M Ω @500 VDC
	Terminals to Coil	
Contact Voltage Drop (initial)	\leq 50mV/10A	
Limit Breaking	30A@450VDC, 5 Cycle	

OPERATE / RELEASE TIME

Operate Time	\leq 30ms @20°C
Release Time	\leq 10ms @20°C

ENVIRONMENTAL DATA

Shock	Functional	196m/s ² Sine half-wave pulse
	Destructive	490m/s ² Sine half-wave pulse
Operating Temperature	-40 to +85°C	
Humidity	5% to 85%RH	
Weight	0.11Lb (50g)	

EXPECTED LIFE

Electrical Endurance (Make/Break) 20A@450VDC	5,000 Cycles
Electrical Endurance (Make/Break) 10A@450VDC	10,000 Cycles
Electrical Endurance (Make Only) 20A@450VDC	75,000 Cycles
Mechanical Life	200,000 Cycles

COIL DATA

Nominal Voltage	12VDC	24VDC
Pick-up Voltage (23°C)	\leq 9VDC	\leq 18VDC
Drop-out Voltage (23°C)	\geq 0.8 VDC	\geq 1.6 VDC
Coil Power 20°C at Nominal Voltage	3W	3W
Rated Coil Resistance \pm 10% (23°C)	48 Ω	192 Ω

Current Carry Curve

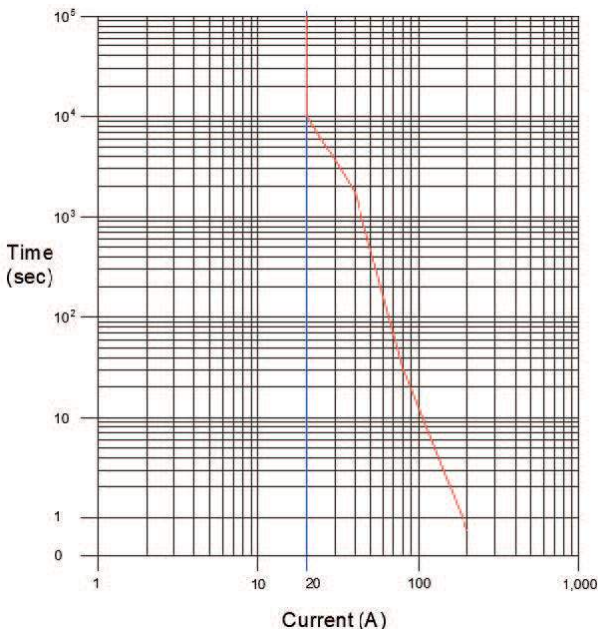

Note:

1. Does not meet dielectric & IR after the test.
2. ON:OFF= 1s:9s.
3. The ambient environment of application should not cause any dewing or icing inside the relay. Otherwise, the relay may fail to work consequently.

Outline Dimensions : inches (mm)

AEV20E

AEV20E(P)

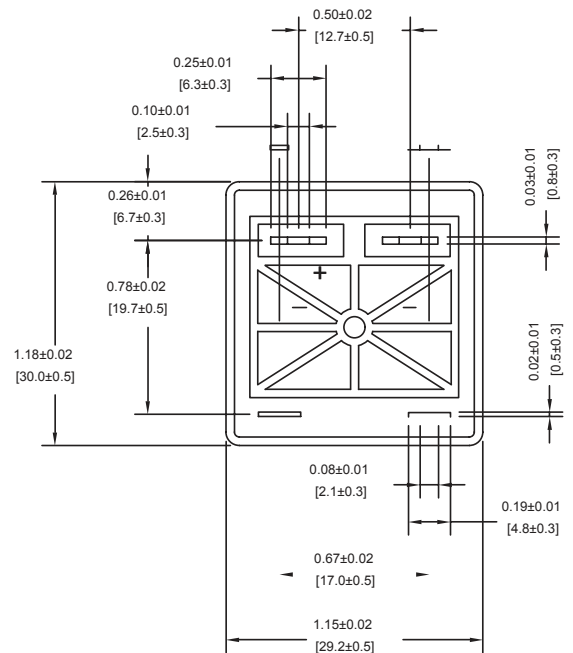
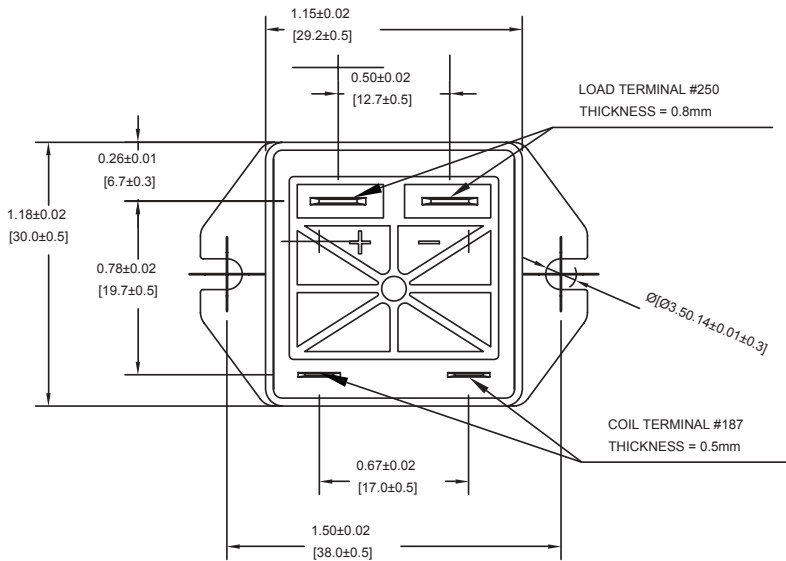
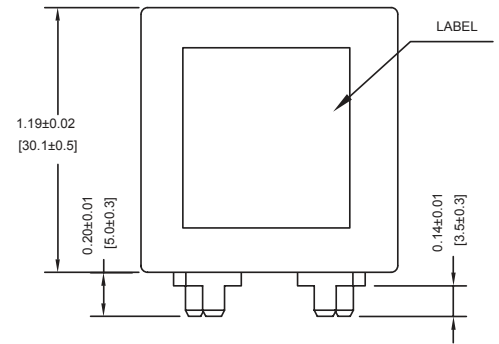
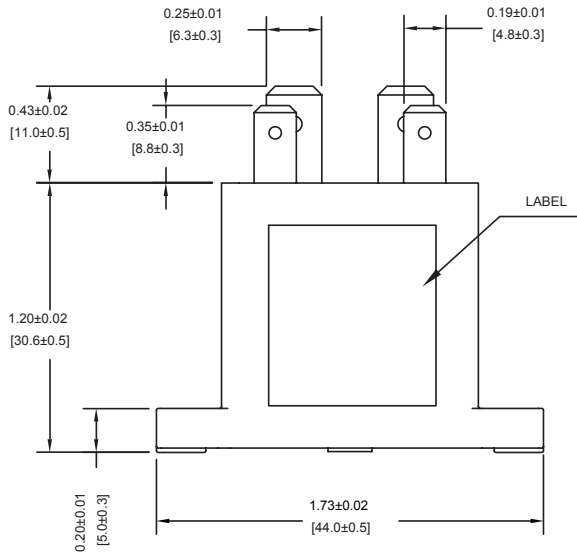

NOTE: There is a "+" and "-" mark on the cover of the product to show the polarity of the load, the coil has no polarity.

Application Notes

1. Please use M3 screws for mounting.
 - Mounting torque: 7 - 9.7 lb. in (0.8-1.1 N.m)
2. Maximum allowable (push-on) force of the terminals is 49Nm.
3. PCB soldering parameters:
 - Manual soldering, 380±20°C, time (3~5)s.
 - Wave soldering 265±5°C, time (3~8)s.
4. Products with polarity marked on the load end must be used correctly according to the product label. When the load connection polarity is reversed, the electrical characteristics in this data sheet cannot be guaranteed.
5. Avoid installing the contactor in a strong magnetic field environment (near transformers or magnets) and avoid placing the contactor near objects with heat radiation.
6. When continuous current is applied to the contacts of the relay, and the coil is turned on immediately after the power is cut off. At this time, as the temperature of the coil increases, the resistance of the coil will also increase, which will increase the pull-in voltage of the product, which may result in exceeding the rated pull-in voltage. In this case, the following measures should be taken to reduce the load current; limit the continuous power-on time or use a coil voltage higher than the rated pull-in voltage.
7. When the voltage applied to both ends of the coil exceeds the maximum allowable applied voltage, the coil temperature may rise and lead to coil damage and interlayer short circuit.
8. The rating in the contact parameters is the value at the time of the resistive load. When using an inductive load with $L/R > 1$ ms, connect a surge current protection device in parallel with the inductive load. If no measures are taken, the electrical life may be degraded and the continuity may be poor. Please consider sufficient margin space in the design.
9. Coil drive power must be greater than coil power or it will reduce performance capability.
10. The load conductor must have the corresponding current load capacity and heat dissipation capacity (it is recommended to use wire with min 4mm²), to prevent overheating and affecting the life of the contactor.
11. Do not use if dropped.
12. It is impossible to determine all the performance parameters of contactors in each specific application, therefore, customers should choose the products according to their own conditions of use. If in doubt, contact Altran. The customer will be responsible for validating that the products meet their application.
13. Altran reserves the right to make changes as needed. Customers should reconfirm the contents of the specification or ask for us to supply a new specification if necessary.