

PART NUMBER	REVISION	DESCRIPTION	FEED TYPE
2150252-2	D	FINE CRIMP HEIGHT ADJUST	PNEUMATIC
7-2150252-2	D	PNEUMATIC AND CRIMP TOOLING KIT	PNEUMATIC
7-2150252-7	A	CRIMP TOOLING KIT	-

ATLANTIC VERSION TERMINATOR INTERFACE ADAPTER

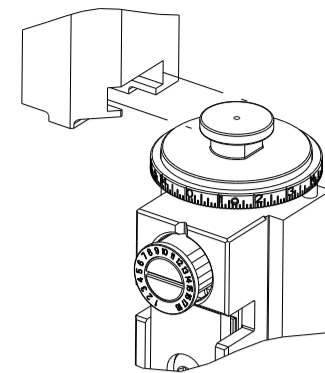

APPLICATOR DATA		
CRIMP	SIZE	TYPE
WIRE	5.11 mm [.201]	D
INSUL	-	-
APPL INSTRUCTIONS 408-35043		

TERMINAL DATA: TE TERMINAL		TE CRIMP SPECIFICATION	
TERMINAL NAME: RECPT, ULTRA-FAST FLAG, .250 SERIES			
WIRE STRIP LENGTH		INSULATION DIAMETER RANGE	
7.51-8.33 mm [.296-.328 IN]		∅ 4.19mm MAX [.165 IN MAX]	
TERMINAL APPLICATION SPECIFICATION	114-2123	-	-
TERMINALS APPLIED			
TE TERMINAL	TE TERMINAL	TE TERMINAL	TE TERMINAL
2-520128-2	2-521164-2	9-521164-2	

WIRE SIZE	CRIMP HEIGHT mm [INCH]	CRIMP HEIGHT REFERENCE SETTING	∅ SOLDER
18 OR (2) 22	1.79+/-0.05 [.070+/-0.002]	5.7	.19 in [4.83mm]
22 OR 20	1.65+/-0.05 [.065+/-0.002]	7.0	.19 in [4.83mm]

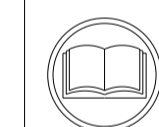

- RECOMMENDED SPARE PARTS
- REFER TO SUPPLIED INSTRUCTION SHEET FOR CLEANING, LUBRICATION AND STORAGE OF APPLICATOR.
- CRIMP HEIGHT REFERENCE SETTING WAS THE SETTING USED WHEN THE APPLICATOR WAS QUALIFIED AT THE FACTORY. ADJUSTMENT MAY BE NECESSARY WHEN RUNNING APPLICATOR IN THE FIELD.
- TERMINAL PITCH NOT COMPATIBLE WITH MECHANICAL FEED.
- TO CHECK CRIMP HEIGHT, CRIMP SOLDER (∅.19 IN [4.83mm] 60/40 SOLID CORE) AND MEASURE AT CENTER OF SLUG.

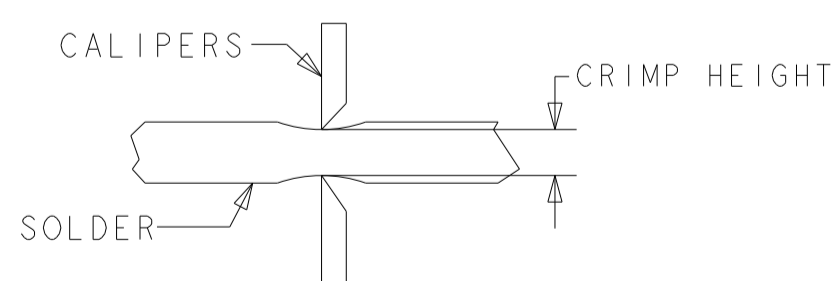

6. UNLESS SPECIFIED OTHERWISE TORQUE VALUES SHALL BE USED PER DOCUMENT, 101-35000.

**\*WARNING**  
ON INSTALLATION, SET WIRE DISC TO CRIMP HEIGHT REFERENCE SETTING FOR LARGEST WIRE SIZE. CRIMP HEIGHT REFERENCE SETTINGS GREATER THAN THE VALUE SHOWN MAY CAUSE DAMAGE TO THE CRIMP TOOLING, REFER TO THE INSTRUCTION SHEET FOR PROPER SETUP AND ADJUSTMENTS.

LOC	DIST	REVISIONS					
A	66	P	LTN	DESCRIPTION	DATE	OWN	APVD
		A		RELEASED	18JAN2013	GH	TE
		B		ECR-18-014348	10SEP2018	JAH	TE
		C		ECR-19-008826	04JUN2019	LG	TE
		D		ECR-23-174392	05MAY2023	FZ	JAH

-	1	1	2119641-1	FEED CAM, AIR FEED	248	
-	1	1	2844940-3	AIR FEED MODULE	238	
-	1	1	467281-1	RETAINER, SHEAR, FLOATING	207	
-	1	1	2161936-1	HOLDER, SHEAR, FLOATING	206	
-	1	1	467500-1	SHEAR, FLOATING	205	
-	1	1	1-18028-0	WASHER, FLAT, REG M8	192	
-	REF	REF	994970-2	COUNTER, MAGNETIC	164	
-	1	1	2161937-1	STABILIZER	154	
-	1	1	1803607-4	DOCUMENTATION PACKAGE	71	
-	1	1	3-18032-3	SCR, SET, FLT PNT, M3 X 20.0	70	
-	1	1	2-18032-2	SCR, SET, FLT PNT, M3 X 10.0	69	
-	1	1	2119740-1	TAG, IDENTIFICATION	67	
-	2	2	2168078-1	SCREW, DRIVE, RH, RoHS, 2 x .188	66	
-	2	2	2168400-4	SHCS, LOW HEAD, RoHS, M4 X 8	60	
-	1	1	5-18022-5	SCR, HEX HD CAP, M4 X 6.0	59	
-	4	4	2168400-1	SHCS, LOW HEAD, RoHS, M4 X 12	57	
-	2	2	2168083-2	SCR, SKT HD CAP, RoHS, M4 X 8.0	56	
-	2	2	5018030-1	NUT, HEX, REG, RoHS, M3	54	
-	2	2	986965-8	NUT, LOCK, HEX, TORQUE (M4)	53	
-	1	1	2352966-1	FEED FINGER	51	
-	1	1	18023-9	SCR, SKT HD CAP M4 X 6.0	49	
-	1	1	1-2119655-5	APPLICATOR BASIC ASSEMBLY, EF	46	
-	1	1	1803517-1	RAM ASSEMBLY, EF ATLANTIC	44	
-	1	1	1803602-1	SCR, BHSC, RoHS (M8 X 25)	41	
-	2	2	5-22278-1	SPRING, COMPRESSION	36	
-	8	8	1-18028-2	WASHER, FLAT, REG M4	33	
-	3	3	2079383-4	SCR, BHSC, RoHS (M4 X 8)	31	
-	2	2	2168083-2	SCR, SKT HD CAP, RoHS, M4 X 8.0	29	
-	1	1	240639-1	STRIPPER (MACHINING)	27	
-	2	2	1-2168083-6	SCR, SKT HD CAP, RoHS, M4 X 35	25	
-	1	1	2161941-1	PLATE, GUIDE, STRIP	24	
-	2	2	2-22281-3	SPRING, COMPRESSION	22	
-	1	1	2161948-1	DRAG	20	
-	1	1	683736-1	GUIDE, STRIP, REAR	19	
-	1	1	683737-1	FRONT STRIP GUIDE	18	
-	4	4	1-2079383-1	SCR, BHSC, RoHS (M6 X 12)	17	
-	1	1	4-22280-7	SPRING, COMPRESSION	13	
-	1	2	1	2161935-1	ANVIL, RIGHT HAND	8
-	1	1	1	2161957-1	DEPRESSOR, SHEAR	5
-	1	1	1	238011-2	BLOCK, CRIMPER SPACER	4
-	1	1	1	2161331-1	SPACER, WIRE FUNNEL DEPRESSOR	2
-	1	2	1	467342-1	CRIMPER, RIGHT HAND	1
-	77	72	-2	PART NO		
-				DESCRIPTION	ITEM NO	

**ATLANTIC VERSION**  
Shown on sheets 1 of 4 & 2 of 4  
(Pacific version shown on sheets 3 of 4 & 4 of 4)

<small>THIS DRAWING IS UNPUBLISHED. RELEASED FOR PUBLICATION. COPYRIGHT 20 BY TYCO ELECTRONICS CORPORATION. ALL RIGHTS RESERVED.</small>		OWN: HOFFNER 11APRIL2012 CHK: T. ELBIN 12APRIL2012 APVD: T. ELBIN 12APRIL2012	TE Connectivity Harrisburg, PA 17105-3608
DIMENSIONS: mm 	TOLERANCES UNLESS OTHERWISE SPECIFIED: 0 PLC ± 1 PLC ± 2 PLC ± 3 PLC ± 4 PLC ± ANGLES ± FINISH ±	NAME: Ocean End Feed Applicator SIZE: A1 CAGE CODE: 00779 DRAWING NO: C=2150252 RESTRICTED TO: -	SCALE: 1:1 SHEET: 1 of 4 REV: D
MATERIAL: -		WEIGHT: -	Customer Accessible Production Drawing

LOC	DIST	REVISIONS			
P	LTN	DESCRIPTION	DATE	OWN	APVD
A	66	SEE SHEET 1			

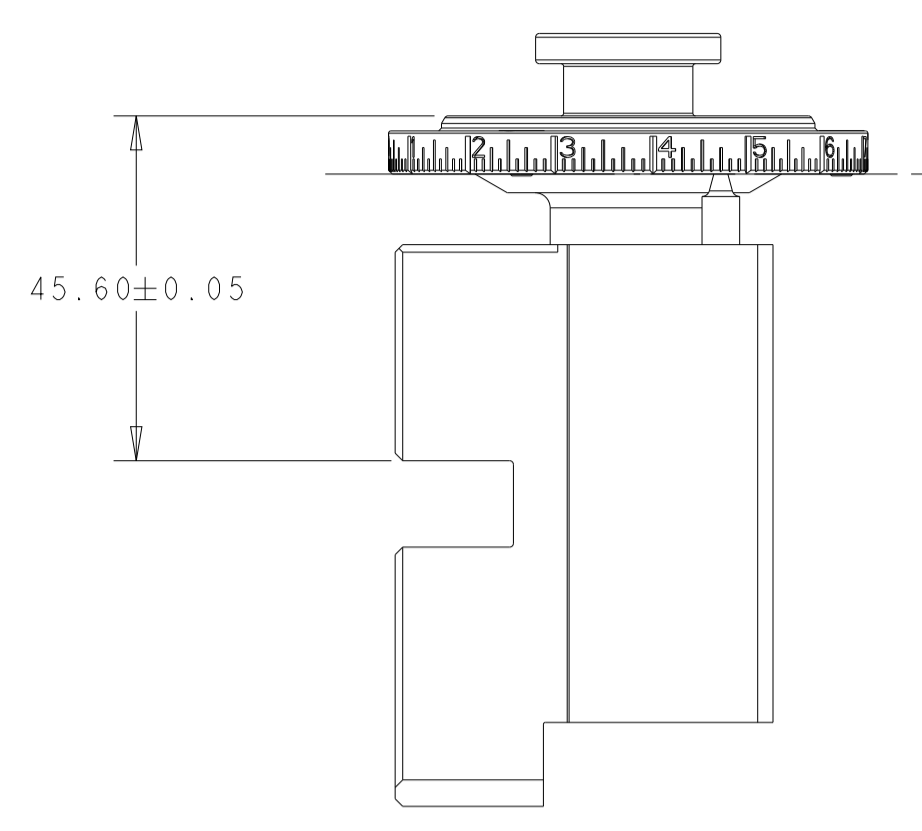

RAM SET-UP

FEED TYPE

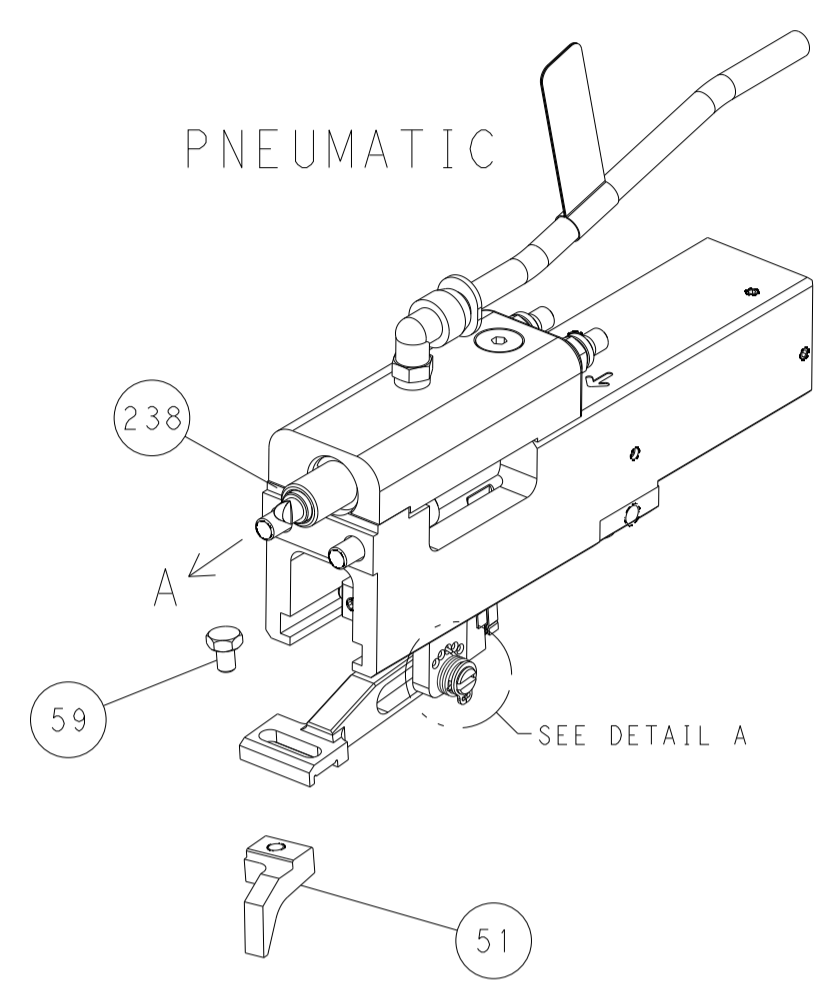

FEED SPRING SETTING POSITION

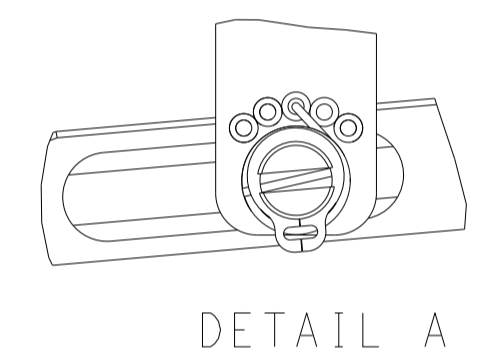

DETAIL A

CAM POSITION

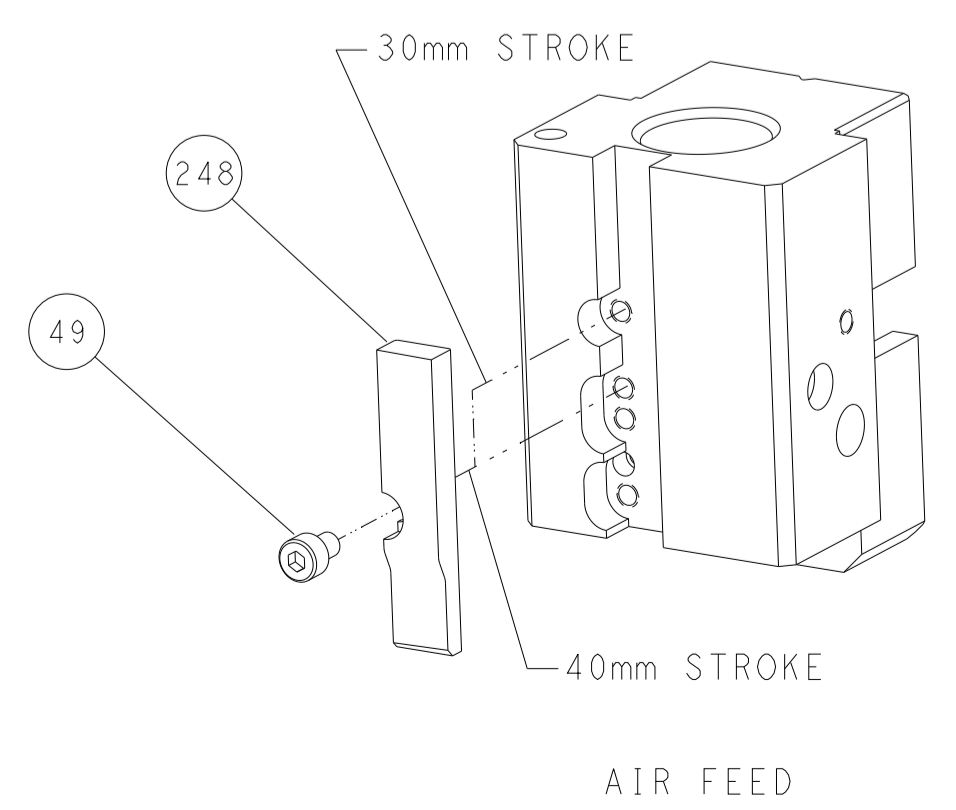

AIR FEED

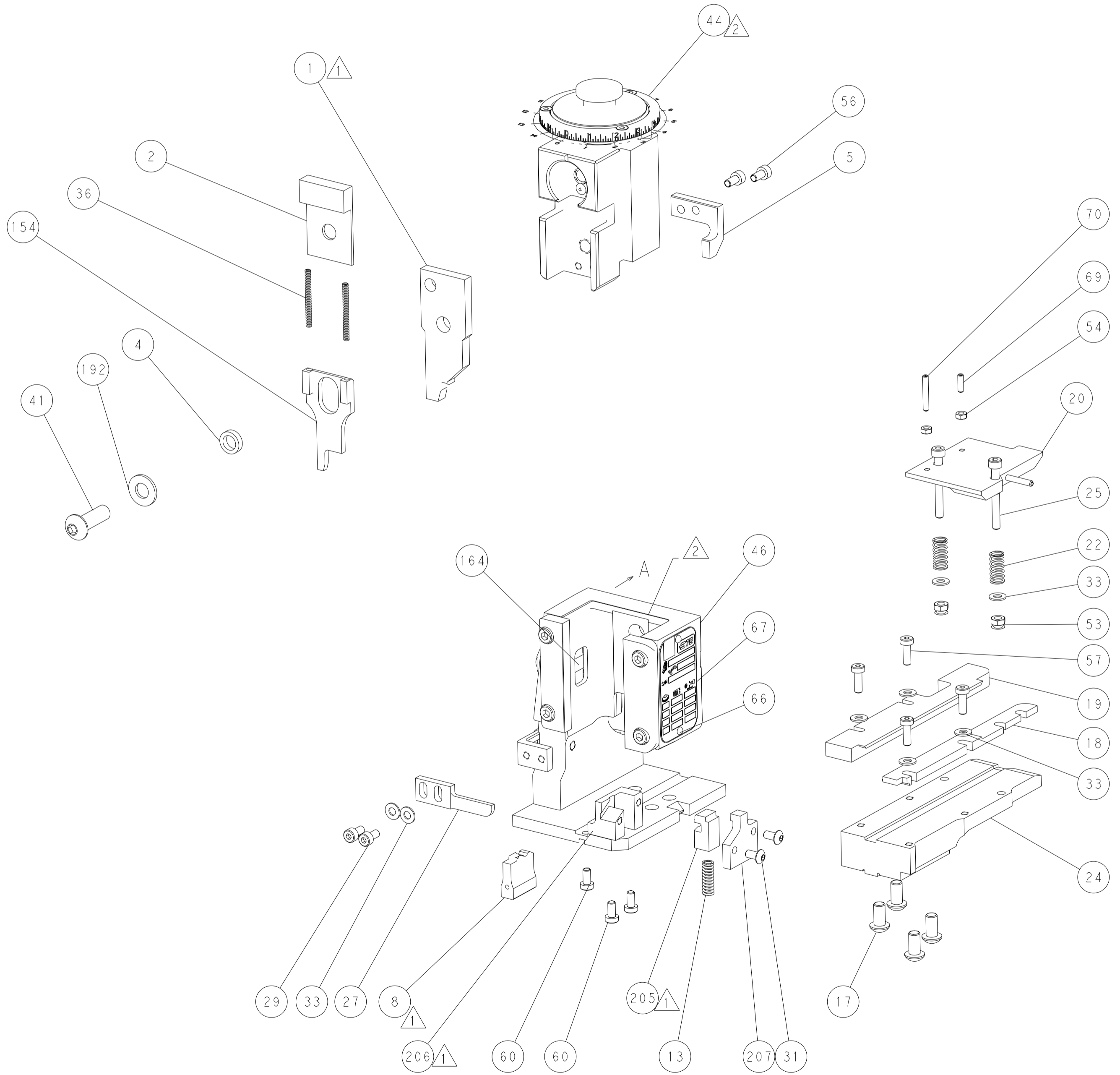

ATLANTIC VERSION  
 Shown on sheets 1 of 4 & 2 of 4  
 (Pacific version shown on sheets 3 of 4 & 4 of 4)

<small>THIS DRAWING IS UNPUBLISHED. RELEASED FOR PUBLICATION 20. COPYRIGHT 20 BY TYCO ELECTRONICS CORPORATION. ALL RIGHTS RESERVED.</small>		DWN: HOFFNER 11APRIL2012 CHK: T. ELBIN 12APRIL2012 APVD: T. ELBIN 12APRIL2012	TE Connectivity Harrisburg, PA 17105-3608
DIMENSIONS: mm 		TOLERANCES UNLESS OTHERWISE SPECIFIED: 0 PLC ± 1 PLC ± 2 PLC ± 3 PLC ± 4 PLC ± ANGLES ± FINISH ±	NAME: Ocean End Feed Applicator SIZE: A1 CAGE CODE: 00779 DRAWING NO: C=2150252 SCALE: 1:1 SHEET: 2 of 4 REV: D
MATERIAL:		WEIGHT:	RESTRICTED TO:

PART NUMBER	REVISION	DESCRIPTION	FEED TYPE
2-2150252-2	D	FINE CRIMP HEIGHT ADJUST	PNEUMATIC
7-2150252-7	A	CRIMP TOOLING KIT	-

PACIFIC VERSION TERMINATOR  
 INTERFACE ADAPTER

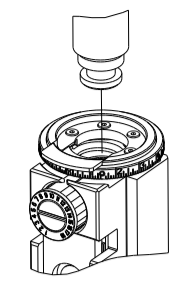

LOC	DIST	REVISIONS					
		P	LTN	DESCRIPTION	DATE	OWN	APVD
A	66	-	-	SEE SHEET 1	-	-	-

APPLICATOR DATA		
CRIMP	SIZE	TYPE
WIRE	5.11 mm [.201]	D
INSUL	-	-
APPL INSTRUCTIONS 408-35043		

TERMINAL DATA: TE TERMINAL		TE CRIMP SPECIFICATION	
TERMINAL NAME: RECPT, ULTRA-FAST FLAG, .250 SERIES			
WIRE STRIP LENGTH 7.51-8.33 mm [.296-.328 IN]		INSULATION DIAMETER RANGE 4.19mm MAX [.165 IN MAX]	
TERMINAL APPLICATION SPECIFICATION	114-2123	-	-
TERMINALS APPLIED			
TE TERMINAL	TE TERMINAL	TE TERMINAL	TE TERMINAL
2-520128-2	2-521164-2	9-521164-2	

WIRE SIZE	CRIMP HEIGHT mm [INCH]	CRIMP HEIGHT REFERENCE SETTING	Ø SOLDER
18 OR (2) 22	1.79+/-0.05 [.070+/-0.002]	5.7	.19 in [4.83mm]
22 OR 20	1.65+/-0.05 [.065+/-0.002]	7.0	.19 in [4.83mm]

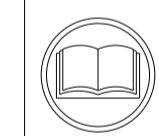

**\*WARNING**  
 ON INSTALLATION, SET WIRE DISC TO CRIMP HEIGHT REFERENCE SETTING FOR LARGEST WIRE SIZE. CRIMP HEIGHT REFERENCE SETTINGS GREATER THAN THE VALUE SHOWN MAY CAUSE DAMAGE TO THE CRIMP TOOLING, REFER TO THE INSTRUCTION SHEET FOR PROPER SETUP AND ADJUSTMENTS.

- 1 RECOMMENDED SPARE PARTS
- 2 REFER TO SUPPLIED INSTRUCTION SHEET FOR CLEANING, LUBRICATION AND STORAGE OF APPLICATOR.
- 3 CRIMP HEIGHT REFERENCE SETTING WAS THE SETTING USED WHEN THE APPLICATOR WAS QUALIFIED AT THE FACTORY. ADJUSTMENT MAY BE NECESSARY WHEN RUNNING APPLICATOR IN THE FIELD.
- 4 TERMINAL PITCH NOT COMPATIBLE WITH MECHANICAL FEED.
- 5 TO CHECK CRIMP HEIGHT, CRIMP SOLDER (Ø.19 IN [4.83mm] 60/40 SOLID CORE) AND MEASURE AT CENTER OF SLUG.

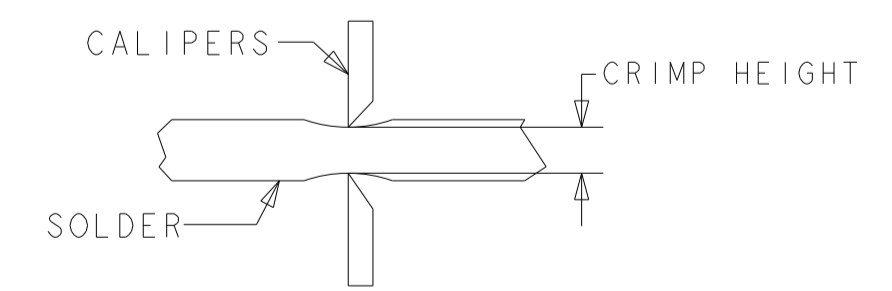

6. UNLESS SPECIFIED OTHERWISE TORQUE VALUES SHALL BE USED PER DOCUMENT, 101-35000.

-	1	2844940-3	AIR FEED MODULE	238
-	1	467281-1	RETAINER, SHEAR, FLOATING	207
-	1	2161936-1	HOLDER, SHEAR, FLOATING	206
-	1	467500-1	SHEAR, FLOATING	205
-	1	1-18028-0	WASHER, FLAT, REG M8	192
-	4	2079383-9	SCR, BHSC, RoHS (M6 X 20)	186
-	REF	994970-2	COUNTER, MAGNETIC	164
-	1	2161937-1	STABILIZER	154
-	1	2119641-2	FEED CAM, AIR FEED	152
-	1	1-2119655-6	APPLICATOR BASIC ASSEMBLY, EF	141
-	1	1803518-1	RAM ASSEMBLY, EF PACIFIC	140
-	1	1803607-4	DOCUMENTATION PACKAGE	71
-	1	3-18032-3	SCR, SET, FLT PNT, M3 X 20.0	70
-	1	2-18032-2	SCR, SET, FLT PNT, M3 X 10.0	69
-	1	2119740-1	TAG, IDENTIFICATION	67
-	2	2168078-1	SCREW, DRIVE, RH, RoHS, 2 x .188	66
-	2	2168400-5	SHCS, LOW HEAD, RoHS, M4 X 20	64
-	1	5-18022-5	SCR, HEX HD CAP, M4 X 6.0	59
-	4	2168400-1	SHCS, LOW HEAD, RoHS, M4 X 12	57
-	2	2168083-2	SCR, SKT HD CAP, RoHS, M4 X 8.0	56
-	2	5018030-1	NUT, HEX, REG, RoHS, M3	54
-	2	986965-8	NUT, LOCK, HEX, TORQUE (M4)	53
-	1	2352966-1	FEED FINGER	51
-	1	18023-9	SCR, SKT HD CAP M4 X 6.0	49
-	1	1803602-1	SCR, BHSC, RoHS (M8 X 25)	41
-	2	5-22278-1	SPRING, COMPRESSION	36
-	8	1-18028-2	WASHER, FLAT, REG M4	33
-	3	2079383-4	SCR, BHSC, RoHS (M4 X 8)	31
-	2	2168083-2	SCR, SKT HD CAP, RoHS, M4 X 8.0	29
-	1	240639-1	STRIPPER (MACHINING)	27
-	2	1-2168083-6	SCR, SKT HD CAP, RoHS, M4 X 35	25
-	1	2161941-1	PLATE, GUIDE, STRIP	24
-	2	2-22281-3	SPRING, COMPRESSION	22
-	1	2161948-1	DRAG	20
-	1	683736-1	GUIDE, STRIP, REAR	19
-	1	683737-1	FRONT STRIP GUIDE	18
-	1	4-22280-7	SPRING, COMPRESSION	13
1	1	2161935-1	ANVIL, RIGHT HAND	8
-	1	2161957-1	DEPRESSOR, SHEAR	5
-	1	238011-2	BLOCK, CRIMPER SPACER	4
-	1	2161331-1	SPACER, WIRE FUNNEL DEPRESSOR	2
1	1	467342-1	CRIMPER, RIGHT HAND	1

**PACIFIC VERSION**  
 Shown on sheets 3 of 4 & 4 of 4  
 (Atlantic version shown on sheets 1 of 4 & 2 of 4)

DIMENSIONS:		TOLERANCES UNLESS OTHERWISE SPECIFIED:		DWG		NAME	
mm	0 PLC ±	1 PLC ±	2 PLC ±	OFFNER	11APRIL2012	STE TE Connectivity Harrisburg, PA 17105-3608	
	3 PLC ±	4 PLC ±	5 PLC ±	ELBIN	12APRIL2012	Ocean End Feed Applicator	
	ANGLES ±	FINISH ±		APVD	12APRIL2012	-	
MATERIAL				APPLICATION SPEC		SIZE	CAGE CODE
						A1	00779
				WEIGHT		SCALE	DRAWING NO
						1:1	2150252
						SHEET	REV
						3	D

