

TLF50201EL & TLF50211EL

2.2 MHz Step-Down Regulator 500 mA
Low quiescent current.

Application Board

16.07.2014



TLF50201EL & TLF50211EL Application Board Introduction



- This application board shall enable You to test the performance of the TLF50201EL and of the TLF50211EL
- 2.2 MHz Step-Down Regulator 500 mA, low quiescent current
- It is equipped with a TLF50211EL with fixed output voltage (5 V)
- The board offers the possibility to modify the schematic
- (please refer to datasheet)

TLF50201EL & TLF50211EL Application Board: How to start

- Connect the Application Board as shown below for a basic Test:

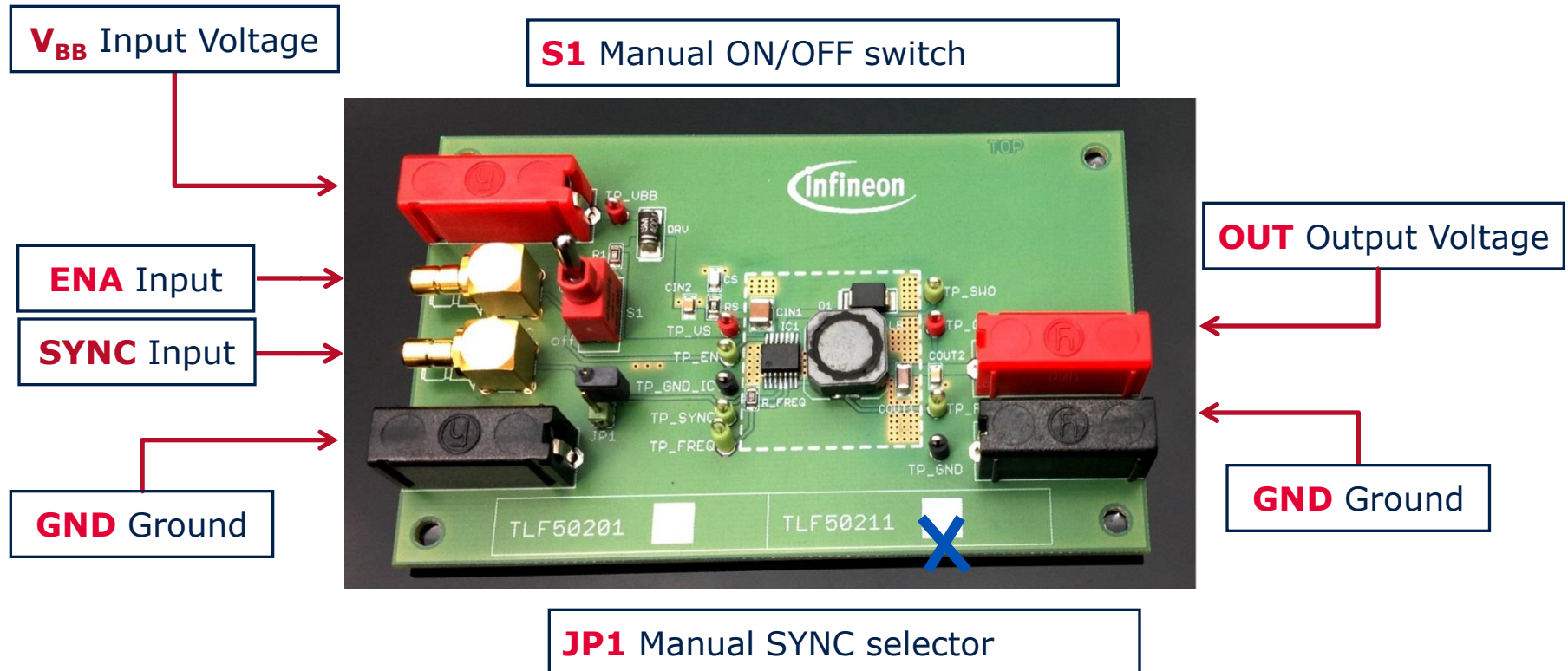

Application board ordering code: **SP000949234**

TLF50201EL & TLF50211EL Application Board Schematic

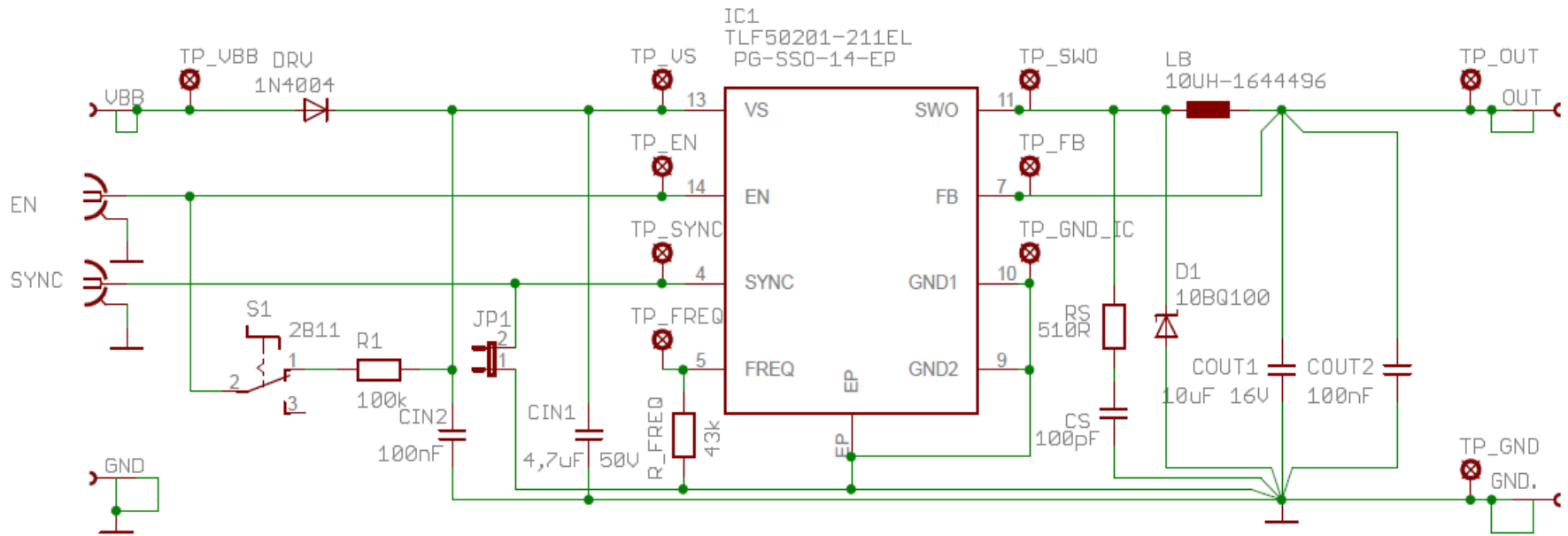

TLF50201EL & TLF50211EL Application Board Layout Details

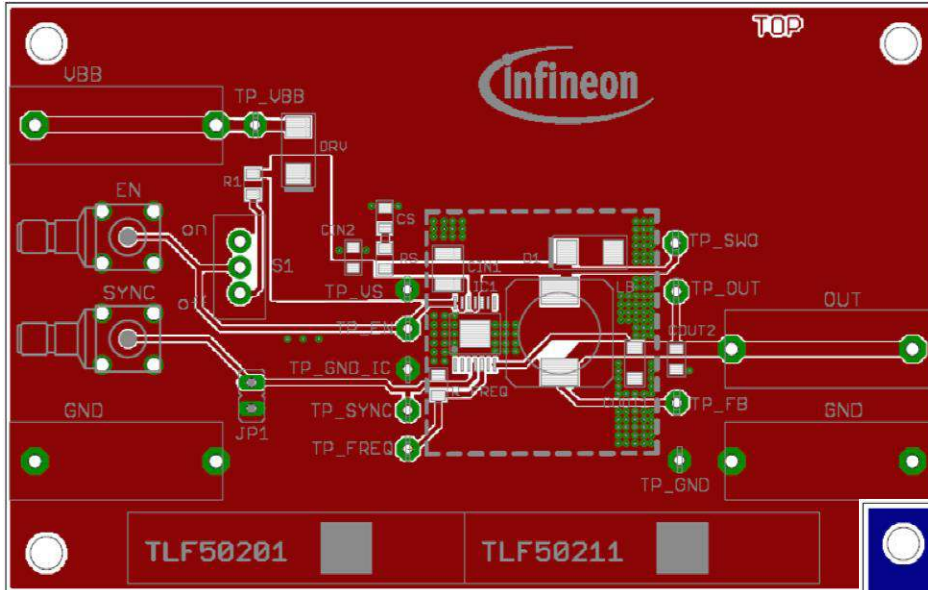

TOP

BOTTOM

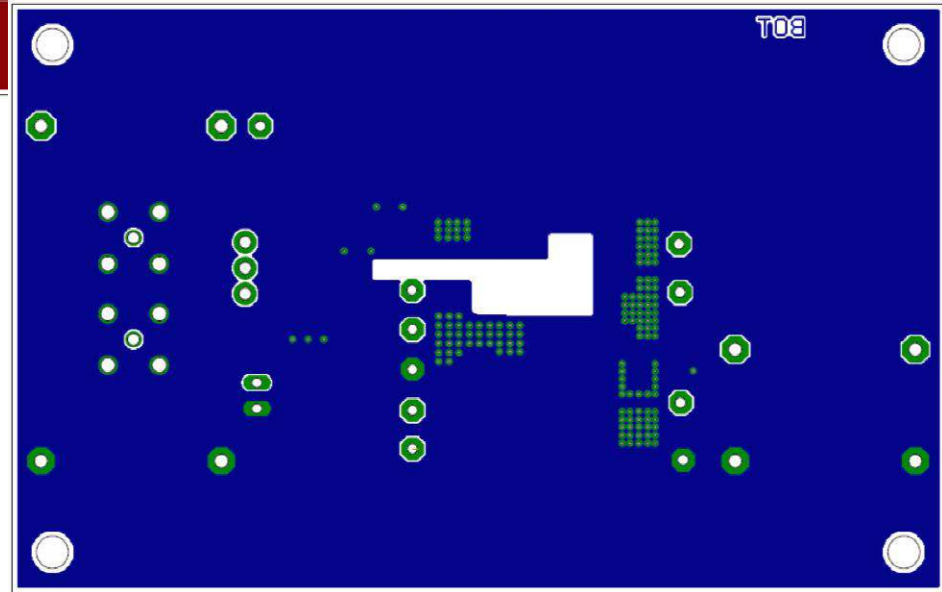

Gerber data on request



ENERGY EFFICIENCY MOBILITY SECURITY

Innovative semiconductor solutions for energy efficiency, mobility and security.

