

NOTES:

1. MATERIALS AND FINISHES:

- HEX NUT - BRASS, WHITE BRONZE PLATING
- LOCK WASHER - BRASS, WHITE BRONZE PLATING
- GASKET - SILICONE RUBBER, RED
- FERRULE - BRASS, WHITE BRONZE PLATING
- SLEEVE - PTFE, NATURAL
- CONTACT - PHOSPHOR BRONZE, GOLD PLATING
- BODY - BRASS, WHITE BRONZE PLATING
- INSULATOR - PTFE, NATURAL

2. ELECTRICAL:

- A. IMPEDANCE: 50 OHM
- B. FREQUENCY RANGE: 0-6 GHz
- C. VSWR (RETURN LOSS): 1.2 MAX. @ 0-4 GHz
- D. INSERTION LOSS: <0.3 dB TO <0.7 dB @ DC-4 GHz
- E. D.W.V: 2500 VRMS, MIN.

3. MECHANICAL:

- A. DURABILITY: 500 CYCLES MIN.
- B. TEMPERATURE RANGE: -65°C TO +165°C

4. CRIMPED FERRULE HEX. CRIMP SIZE .255"

5. CRIMPED CONTACT PIN HEX. CRIMP SIZE .105" OR SOLDER

6. MAX. PANEL THICKNESS=6.5MM

SHOWS CABLE ENTRY DIMENSIONS.

THIRD ANGLE PROJ.

REVISIONS

REV	DESCRIPTION	DATE	ECO	APPR
A	RELEASE TO MFG.	25-Mar-15	2887	BCG

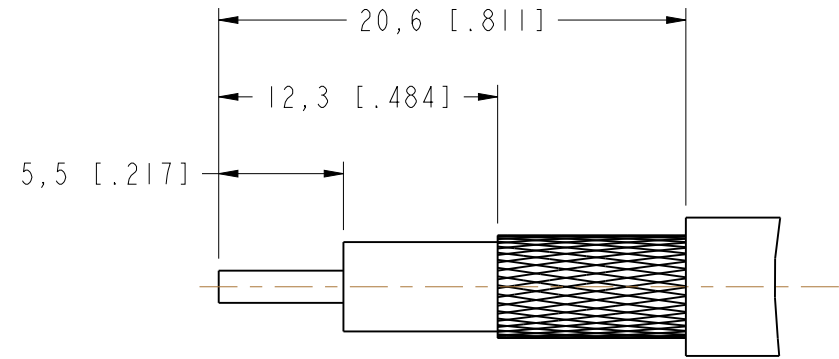

RECOMMENDED CABLE STRIPPING DIM'S

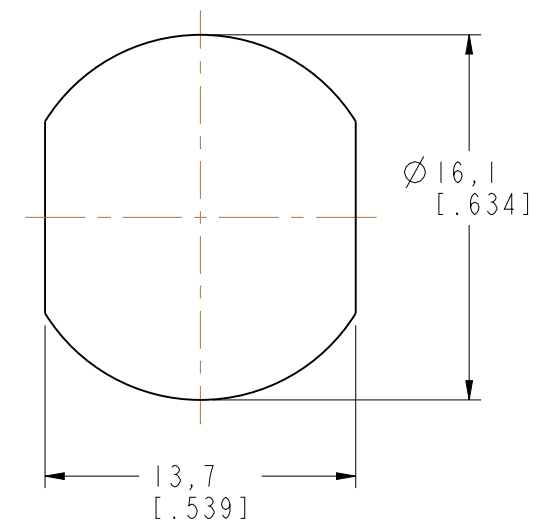

RECOMMENDED MOUNTING HOLE

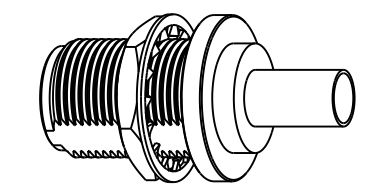

SCALE 1.000

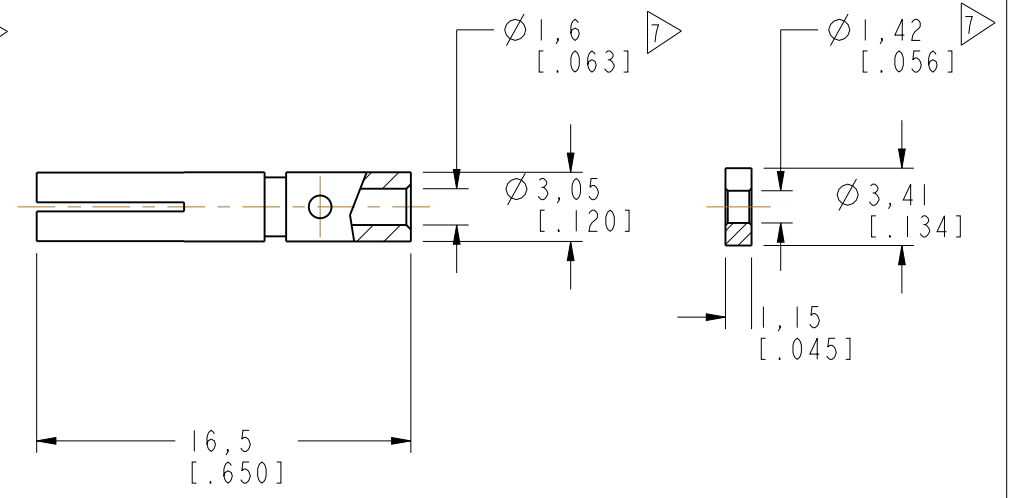
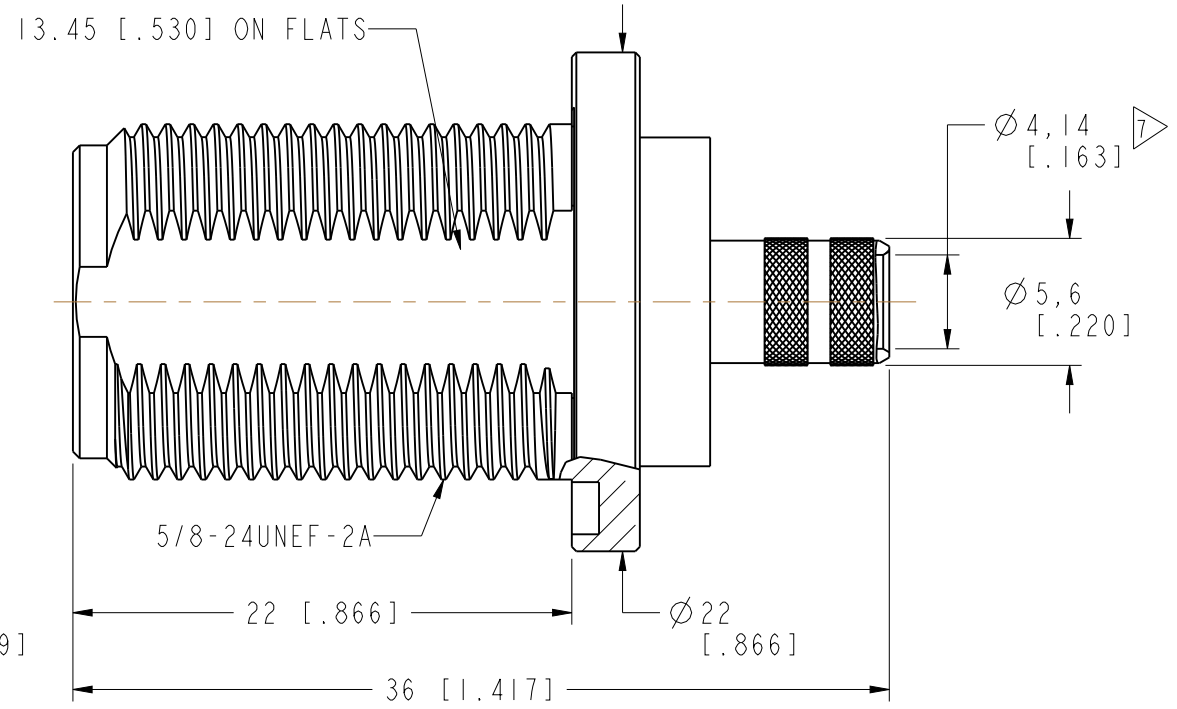
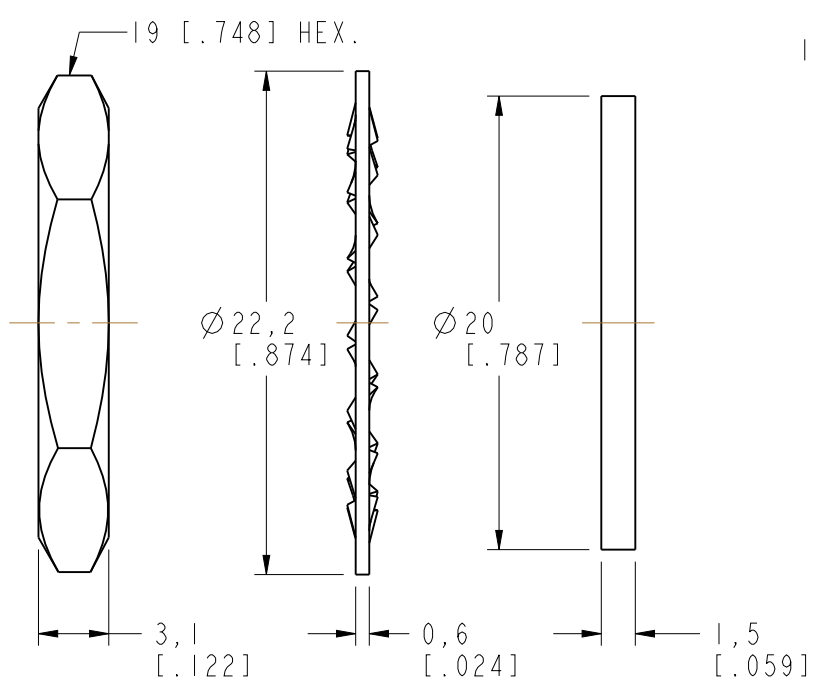
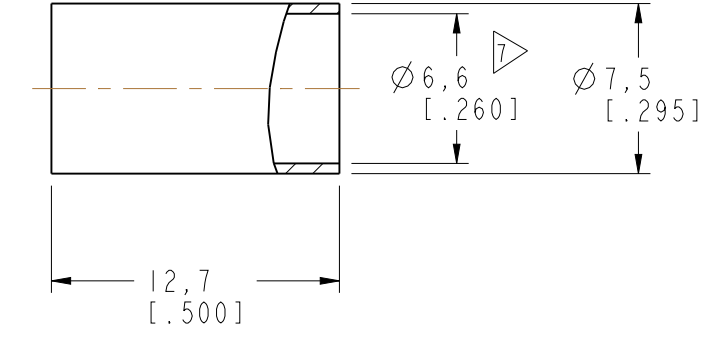

CUSTOMER OUTLINE DRAWING
ALL OTHER SHEETS ARE FOR INTERNAL USE ONLY

<p>UNLESS OTHERWISE SPECIFIED, DIMENSIONS ARE IN METRIC AND TOLERANCES ARE: <0.5mm ±0.05mm 0.5 - 6mm ±0.1mm 6 - 30mm ±0.2mm 30 - 120mm ±0.3mm ANGLES ±1°</p> <p>NOTICE - These drawings, specifications, or other data (1) are, and remain the property of Amphenol corp. (2) must be returned upon request; and (3) are confidential and not to be disclosed to any person other than those to whom they are given by Amphenol Corp. the furnishing of these drawings, specifications, or other data by Amphenol Corp., or to any other person to anyone for any purpose is not to be regarded by implication or otherwise in any manner licensing, granting rights to permitting such holder or any other person to manufacture, use or sell any product, process or design, patented or otherwise, that may in any way be related to or disclosed by said drawings, specifications, or other data.</p>	MATERIAL	DRAWN R.MAO	DATE 10-Dec-14	TITLE N BULKHEAD CRIMP JACK (FOR LMR-240 CABLE)	Amphenol Connex DRAWING NO. ITEM NO. PART NO. 172386
	REFERENCE EAR# 6467 N6421A1-AT5GP-LMR240-50 CONFIGURATION LEVEL: In Work	ENGINEER R.MAO	DATE 10-Dec-14	APPROVED B.C. GLEISSNER	
FINISH	CAD FILE	DWG SIZE B	REV A	SCALE: 3.0:1.0 SHEET 3 OF 3	