

## Evaluation Board for the **AD5116** Digital Potentiometer

### FEATURES

Full-featured evaluation board for the **AD5116**  
 Several test circuits  
 Various ac/dc input signals

### PACKAGE CONTENTS

EVAL-AD511xSDZ evaluation board  
 CD that includes  
 Electronic version of the **AD5116** data sheet  
 Electronic version of the UG-324 user guide

### GENERAL DESCRIPTION

This user guide describes the evaluation board for evaluating the **AD5116**—a single-channel, 64-position, nonvolatile memory digital potentiometer.

The **AD5116** supports single-supply 2.3 V to 5.5 V operation, making the device suited for battery-powered applications and many other applications, offering guaranteed low resistor tolerance errors of  $\pm 8\%$  and high bandwidth while allowing up to  $\pm 6$  mA current density in the A, B, and W pins.

A simple push-button interface allows manual switching and can save the last wiper position automatically into the EEPROM, making it suits to applications that require a power-up in the last wiper position.

Complete specifications for the **AD5116** part can be found in the **AD5116** data sheet, which is available from Analog Devices, Inc., and should be consulted in conjunction with this user guide when using the evaluation board.

### DIGITAL PICTURE OF EVALUATION BOARD



Figure 1.

**TABLE OF CONTENTS**

Features .....	1	ASE Configuration .....	3
Package Contents .....	1	Push Buttons .....	3
General Description .....	1	Test Circuits .....	4
Digital Picture of Evaluation Board .....	1	Evaluation Board Schematics and Artwork .....	5
Revision History .....	2	Ordering Information .....	8
Evaluation Board Hardware .....	3	Bill of Materials .....	8
Power Supplies .....	3		

**REVISION HISTORY**

11/11—Revision 0: Initial Version

## EVALUATION BOARD HARDWARE

### POWER SUPPLIES

The EVAL-AD5116SBZ supports using single power supplies.

The evaluation board should be powered externally by the EXTERNAL-1 and EXTERNAL-2 connectors, as described in Table 2. The link LK8 should be connected as shown in Table 1.

All supplies are decoupled to ground using 10  $\mu$ F tantalum and 0.1  $\mu$ F ceramic capacitors.

**Table 1. Link Connections**

Link No.	Option
LK8	+5V and EXT

**Table 2. Maximum and Minimum Voltages of the Connectors**

Connector No.	Label	Voltage
EXTERNAL-1	VDD	Analog positive power supply, $V_{DD}$ . It is 2.3 V to 5.5 V.
EXTERNAL-2	AGND	Analog ground, AGND.

### ASE CONFIGURATION

The part allows the user to configure the automatic store enable before powering up the board. If the ASE function is enabled, the led, D2, indicates when minimum/maximum resistance has been reached. The [AD5116](#) data sheet provides a detailed description of this pin.

### PUSH BUTTONS

The EVAL-AD5116EBZ provides three switches to operate the part:

- PU. This switch increases the resistance between  $R_{WB}$ .
- PD. This switch decreases the resistance between  $R_{WB}$ .
- NVM. This push button is enabled when the ASE function is disabled and allows manually storage of the RDAC register into the NVM.

**TEST CIRCUITS**

The EVAL-AD5116EBZ incorporates several test circuits to evaluate the AD5116 performance.

**DAC**

The AD5116 can be operated as a digital-to-analog converter (DAC), as shown in Figure 2.

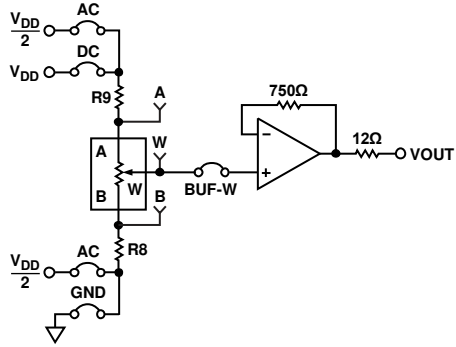

Figure 2. DAC

Table 3 shows the options available for the voltage references.

**Table 3. DAC Voltage References**

Terminal	Link	Options	Description
A	LK1	AC DC	Connects Terminal A to V <sub>DD</sub> /2 Connects Terminal A to V <sub>DD</sub>
W	BUF-W		Connects Terminal W to an output buffer
B	LK6	AC GND	Connects Terminal B to V <sub>DD</sub> /2 Connects Terminal B to analog ground

The output voltage is defined in Equation 1.

$$V_{OUT} = (V_A - V_B) \times \frac{RDAC}{256} \tag{1}$$

where:

- RDAC is the code loaded in the RDAC register.
- V<sub>A</sub> is the voltage applied to Terminal A (LK1 link).
- V<sub>B</sub> is the voltage applied to Terminal B (LK6 link).

However, by using the R8 and R9 external resistors, the user can reduce the voltage of the voltage references. In this case, use the A and B test points to measure the voltage applied to the A and B terminals and recalculate V<sub>A</sub> and V<sub>B</sub> in Equation 1.

**AC Signal Attenuation**

The AD5116 can be used to attenuate an ac signal, which must be provided externally using the AC\_INPUT connector, as shown in Figure 3.

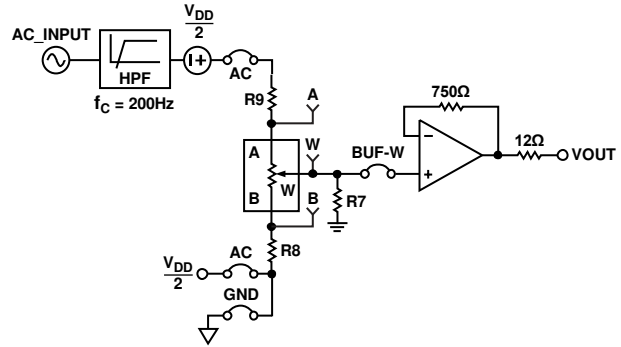

Figure 3. AC Signal Attenuator

Depending on the voltage supply rails and the dc offset voltage of the ac signal, various configurations can be used as described in Table 4.

**Table 4. AC Signal Attenuation Link Options**

Terminal	Link	Options	Description
A	LK1	AC	Remove dc voltage and biased the signal to V <sub>DD</sub> /2
W	BUF-W		Connects Terminal W to an output buffer
B	LK6	AC1 GND	Connects Terminal B to V <sub>DD</sub> /2 Connects Terminal B to analog ground

<sup>1</sup> Recommended to ensure optimal total harmonic distortion (THD) performance. The signal attenuation is defined in Equation 2.

$$Attenuation \text{ (dB)} \approx 20 \times \log\left(\frac{RDAC}{128}\right) \tag{2}$$

where:

RDAC is the code loaded in the RDAC register.

In addition, R7 can be used to achieve an exponential attenuation. To do so, adjust the R7 resistor until a desirable transfer function is found, typically value is around 1.6 kΩ for a 10 kΩ potentiometer.

# EVALUATION BOARD SCHEMATICS AND ARTWORK

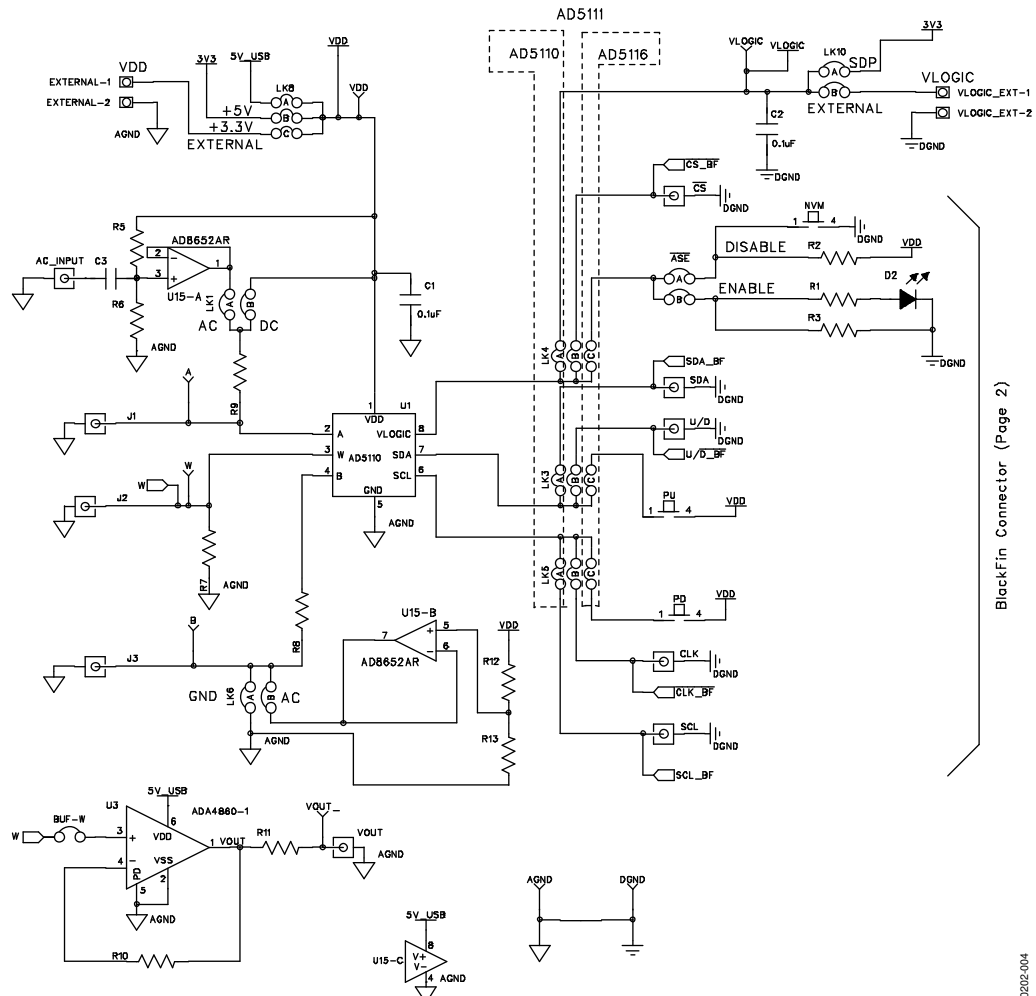

BlackFin Connector (Page 2)

10202-004

Figure 4. Schematic of the AD5116 Circuitry

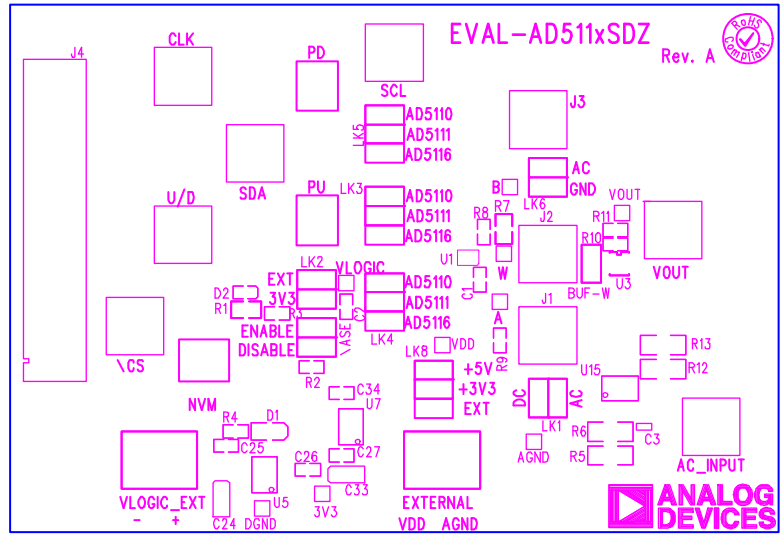

Figure 5. Component Placement Drawing

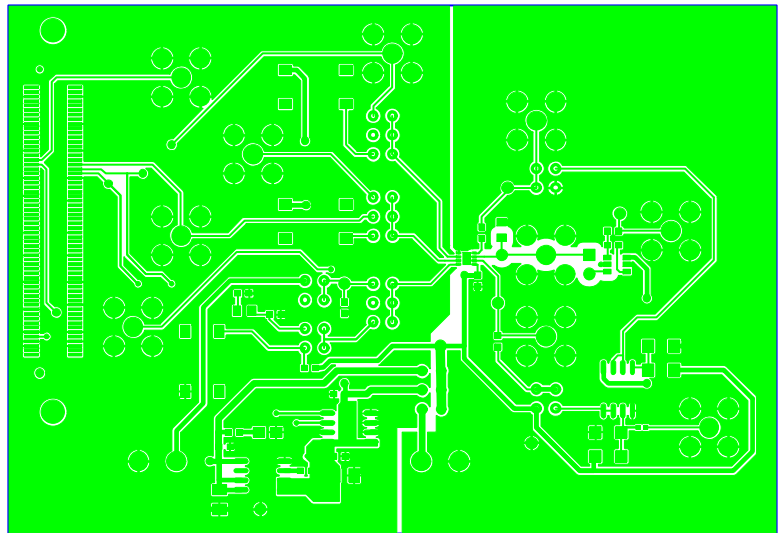

Figure 6. Component Side PCB Drawing

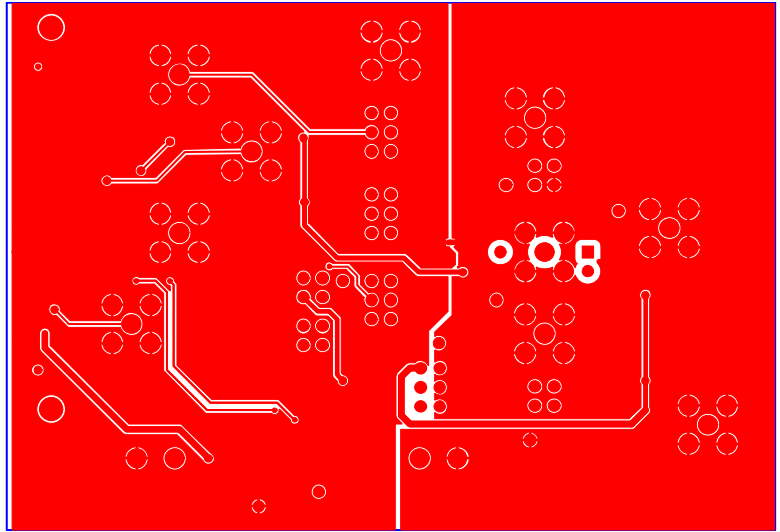

Figure 7. Solder Side PCB Drawing

110202-008

## ORDERING INFORMATION

## BILL OF MATERIALS

Table 5.

Qty	Reference Designator	Description	Supplier <sup>1</sup> /Part Number
1	C3	100 nF capacitor, 0402	FEC 1414580
1	C1	0.1 $\mu$ F capacitor, 0603	FEC 138-2224
1	C25	0.1 $\mu$ F capacitor, 0603	FEC 301-9482
1	C24	10 $\mu$ F capacitor, 1206	FEC 197-130
1	D1	LED, green	FEC 579-0852
1	D2	LED, red	FEC 1685068
1	EXTERNAL	2-pin connector	FEC 151789
3	PD, PU, NVM	Push-button	FEC 177-807
7	LK1, LK3, LK4, LK5, LK6, LK8, ASE	Header, 2-row, 36 + 36 way, and jumper socket, black	FEC 148-535 and FEC 150-411
1	BUF-W	Header, 1-row, 2-way, and jumper socket, black	FEC 102-2247 and FEC 150-411
1	R11	12 $\Omega$ resistor, 0603, 1%	FEC 9330534
1	R10	750 $\Omega$ resistor, 0603, 1%	FEC 9331506
1	R4	1 k $\Omega$ resistor, 0603, 0.01%	FEC 9330380
1	R1	1.8 k $\Omega$ resistor, 0805, 1%	FEC 1400055
4	R5, R6, R12, R13	2.7 k $\Omega$ resistor, 1206, 1%	FEC 9337288
2	R2, R3	110 k $\Omega$ resistor, 0603, 1%	FEC 9331247
2	R8, R9	0 $\Omega$ resistor, 0603	FEC 9331662
2	DGND, AGND	Test point, PCB, black, PK100	FEC 873-1128
6	3V3, A, B, VDD, VOUT, W	Test point, PCB, red, PK100	FEC 873-1144
1	U1	<a href="#">AD5116</a>	Analog Devices <a href="#">AD5116</a>
1	U3	<a href="#">ADA4860</a>	Analog Devices <a href="#">ADA4860</a>
1	U15	<a href="#">AD8652</a>	Analog Devices <a href="#">AD8652</a>

<sup>1</sup> FEC refers to Farnell Electronic Component Distributors.

<sup>12</sup>C refers to a communications protocol originally developed by Philips Semiconductors (now NXP Semiconductors).

**ESD Caution**

**ESD (electrostatic discharge) sensitive device.** Charged devices and circuit boards can discharge without detection. Although this product features patented or proprietary protection circuitry, damage may occur on devices subjected to high energy ESD. Therefore, proper ESD precautions should be taken to avoid performance degradation or loss of functionality.

**Legal Terms and Conditions**

By using the evaluation board discussed herein (together with any tools, components documentation or support materials, the "Evaluation Board"), you are agreeing to be bound by the terms and conditions set forth below ("Agreement") unless you have purchased the Evaluation Board, in which case the Analog Devices Standard Terms and Conditions of Sale shall govern. Do not use the Evaluation Board until you have read and agreed to the Agreement. Your use of the Evaluation Board shall signify your acceptance of the Agreement. This Agreement is made by and between you ("Customer") and Analog Devices, Inc. ("ADI"), with its principal place of business at One Technology Way, Norwood, MA 02062, USA. Subject to the terms and conditions of the Agreement, ADI hereby grants to Customer a free, limited, personal, temporary, non-exclusive, non-sublicensable, non-transferable license to use the Evaluation Board FOR EVALUATION PURPOSES ONLY. Customer understands and agrees that the Evaluation Board is provided for the sole and exclusive purpose referenced above, and agrees not to use the Evaluation Board for any other purpose. Furthermore, the license granted is expressly made subject to the following additional limitations: Customer shall not (i) rent, lease, display, sell, transfer, assign, sublicense, or distribute the Evaluation Board; and (ii) permit any Third Party to access the Evaluation Board. As used herein, the term "Third Party" includes any entity other than ADI, Customer, their employees, affiliates and in-house consultants. The Evaluation Board is NOT sold to Customer; all rights not expressly granted herein, including ownership of the Evaluation Board, are reserved by ADI. CONFIDENTIALITY. This Agreement and the Evaluation Board shall all be considered the confidential and proprietary information of ADI. Customer may not disclose or transfer any portion of the Evaluation Board to any other party for any reason. Upon discontinuation of use of the Evaluation Board or termination of this Agreement, Customer agrees to promptly return the Evaluation Board to ADI. ADDITIONAL RESTRICTIONS. Customer may not disassemble, decompile or reverse engineer chips on the Evaluation Board. Customer shall inform ADI of any occurred damages or any modifications or alterations it makes to the Evaluation Board, including but not limited to soldering or any other activity that affects the material content of the Evaluation Board. Modifications to the Evaluation Board must comply with applicable law, including but not limited to the RoHS Directive. TERMINATION. ADI may terminate this Agreement at any time upon giving written notice to Customer. Customer agrees to return to ADI the Evaluation Board at that time. LIMITATION OF LIABILITY. THE EVALUATION BOARD PROVIDED HEREUNDER IS PROVIDED "AS IS" AND ADI MAKES NO WARRANTIES OR REPRESENTATIONS OF ANY KIND WITH RESPECT TO IT. ADI SPECIFICALLY DISCLAIMS ANY REPRESENTATIONS, ENDORSEMENTS, GUARANTEES, OR WARRANTIES, EXPRESS OR IMPLIED, RELATED TO THE EVALUATION BOARD INCLUDING, BUT NOT LIMITED TO, THE IMPLIED WARRANTY OF MERCHANTABILITY, TITLE, FITNESS FOR A PARTICULAR PURPOSE OR NON-INFRINGEMENT OF INTELLECTUAL PROPERTY RIGHTS. IN NO EVENT WILL ADI AND ITS LICENSORS BE LIABLE FOR ANY INCIDENTAL, SPECIAL, INDIRECT, OR CONSEQUENTIAL DAMAGES RESULTING FROM CUSTOMER'S POSSESSION OR USE OF THE EVALUATION BOARD, INCLUDING BUT NOT LIMITED TO LOST PROFITS, DELAY COSTS, LABOR COSTS OR LOSS OF GOODWILL. ADI'S TOTAL LIABILITY FROM ANY AND ALL CAUSES SHALL BE LIMITED TO THE AMOUNT OF ONE HUNDRED US DOLLARS (\$100.00). EXPORT. Customer agrees that it will not directly or indirectly export the Evaluation Board to another country, and that it will comply with all applicable United States federal laws and regulations relating to exports. GOVERNING LAW. This Agreement shall be governed by and construed in accordance with the substantive laws of the Commonwealth of Massachusetts (excluding conflict of law rules). Any legal action regarding this Agreement will be heard in the state or federal courts having jurisdiction in Suffolk County, Massachusetts, and Customer hereby submits to the personal jurisdiction and venue of such courts. The United Nations Convention on Contracts for the International Sale of Goods shall not apply to this Agreement and is expressly disclaimed.