

DC Fan



Ø 172x150x51 mm

San Ace 172 9GV type

Sidecut type

General Specifications

- Material Frame: Aluminum, Impeller: Plastic (Flammability: UL 94V-1)
- Expected life See the table below. (L10 life: 90% survival rate for continuous operation in free air at 60°C, rated voltage)
Expected life at 40°C is for reference only.
- Motor protection function Locked rotor burnout protection, Reverse polarity protection
For details, please refer to p. 599.
- Dielectric strength 50/60 Hz, 500 VAC, for 1 minute (between lead wire conductors and frame)
- Insulation resistance 10 MΩ or more with a 500 VDC megger (between lead wire conductors and frame)
- Sound pressure level (SPL) At 1 m away from the air inlet
- Storage temperature -30 to +70°C (Non-condensing)
- Lead wire ⊕Red ⊖Black Sensor Yellow
- Mass 800 g

Specifications

The models listed below **have pulse sensors.**

Model no.	Rated voltage [V]	Operating voltage range [V]	Rated current [A]	Rated input [W]	Rated speed [min ⁻¹]	Max. airflow [m ³ /min] [CFM]	Max. static pressure [Pa] [inchH ₂ O]	SPL [dB (A)]	Operating temperature [°C]	Expected life [h]
9GV5724H501	24	20.4 to 27.6	4.0	96	6300	11.32 400	690 2.77	74	-20 to +70	40000/60°C (70000/40°C)
9GV5748H501	48	40.8 to 55.2	2.0	96	6300	11.32 400	690 2.77	74		

Note: Sensor and control options are available for selection. Refer to the table on p. 633.

Airflow - Static Pressure Characteristics

9GV5724H501 With pulse sensor

Operating voltage range

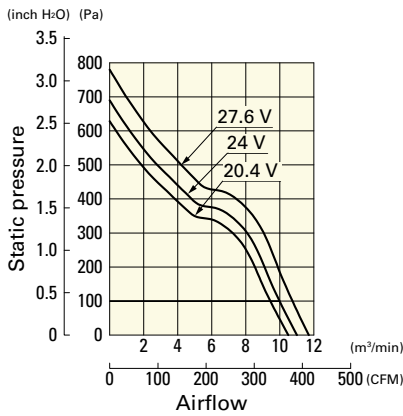

9GV5748H501 With pulse sensor

Operating voltage range

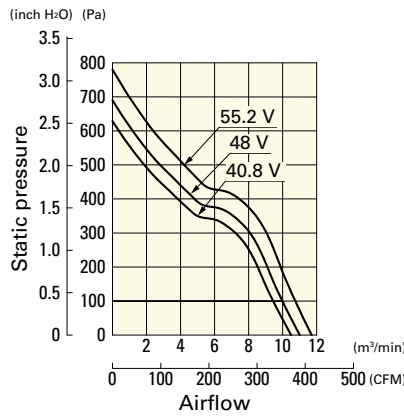

Dimensions (unit: mm)

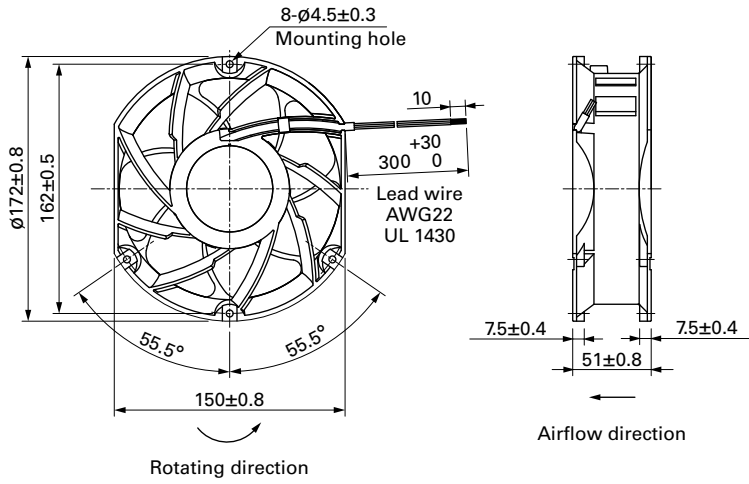

Reference Dimensions of Mounting Holes and Vent Opening (unit: mm)

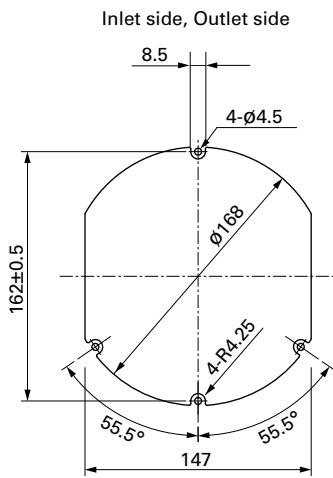

Options

Finger guards

page: p. 586

Model no.: 109-319J, 109-319E, 109-319H, 109-320