

LOC	DIST	REVISIONS				
		REV	DESCRIPTION	DATE	OWN	APVD
A1	-	A14	Dimension min. 1.25 was at misleading position	08AUG2017	FRAN	BECK
		A15	NEW VARIANT 5-1241400-1; 5-1241410-1 and 5-1241410-3	09APR2018	FRAN	BECK
		A16	NEW PN 1-2333550-3; 1-2333551-3; 1-2333552-3 AT SHEET 2	03DEC2020	FRAN	BECK
		A17	PCN-22-158848	22NOV2022	FRAN	KIEF

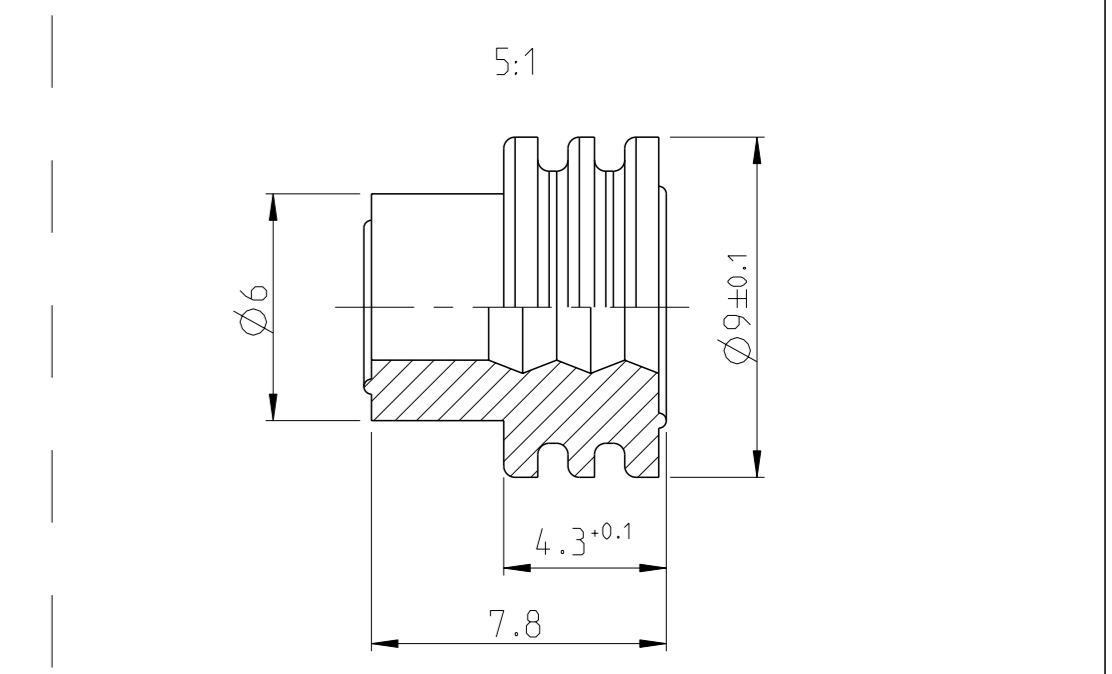

SINGLE WIRE SEAL Einzel-Dichtung		
ORDER NO. Bestell-Nr.	INSULATION-Ø Isolations-Ø	COLOUR Farbe
2177018-1	1.2-2.0	YELLOW gelb
1394511-1	2.0-2.7	WHITE weiss
1823111-1	2.7-3.0	REDBROWN rotbraun
1394512-1	3.4-3.7	BLUE blau
1719043-1	4.0-4.5	GREEN gruen

ORDER NO. STRIP Bestell-Nr. Bandware	Rev.	WIRE RANGE Drahtgrößen Bereich (mm 2)	INSULATION-Ø Isolations-Ø (mm)	MATERIAL Werkstoff	SURFACE IN CONTACT AREA Oberflaeche im Kontaktbereich	CRIMP DIMENSION Crimpabmessungen (mm)				WIRE CRIMP Drahtcrimp	INSULATION CRIMP Isolations Crimp
						A	B	C	F		
1241418-4	A				TIN PLATED / SnAg verzinkt / SnAg					E = 5.3 G = 5.6 D <sub>Dr</sub> = 2.9	H1= 8.15 H2= 7.0 K = 7.9 D <sub>Iso</sub> = 6.0
2-1241418-3	A	4.0-6.0	3.4-4.3	CuNiSi	SILVER PLATED versilbert	4.5	6.9	8.7	20.95		
1-1241418-3	A				SILVER PLATED versilbert						
1241416-3	A	>2.5-4.0	3.4-4.5	CuNiSi	SILVER PLATED versilbert	4.0	5.9	7.7	19.95	E = 4.6 G = 4.8 D <sub>Dr</sub> = 2.4	H1= 8.15 H2= 7.0 K = 7.9 D <sub>Iso</sub> = 6.0
1241416-1	A				TIN PLATED verzinkt						
1241414-3	A	>1.0-2.5	2.2-3.7	CuNiSi	SILVER PLATED versilbert	3.5	5.9	7.7	19.95	E = 3.8 G = 4.0 D <sub>Dr</sub> = 1.7	H1= 8.15 H2= 7.0 K = 7.9 D <sub>Iso</sub> = 5.7
1241414-1	A				TIN PLATED verzinkt						
1241412-3	A	0.5-1.0	1.4-2.7	CuNiSi	SILVER PLATED versilbert	3.0	5.4	7.2	19.95	E = 2.8 G = 3.0 D <sub>Dr</sub> = 1.1	H1= 7.8 H2= 6.7 K = 7.5 D <sub>Iso</sub> = 5.5
1241412-1	A				TIN PLATED verzinkt						
5-1241410-3	A				SILVER PLATED versilbert						
1241410-3	A	0.35-0.5	1.2-2.3	CuNiSi	SILVER PLATED versilbert	2.5	4.9	6.7	19.95	E = 2.2 G = 2.2 D <sub>Dr</sub> = 0.8	H1= 7.7 H2= 6.6 K = 7.5 D <sub>Iso</sub> = 5.5
5-1241410-1	A				TIN PLATED verzinkt						
1241410-1	A				TIN PLATED verzinkt						
2-1241408-3	A	4.0-6.0	3.4-4.3	CuNiSi	SILVER PLATED versilbert	4.5	6.0	7.8	19.95	E = 5.3 G = 5.6 D <sub>Dr</sub> = 2.9	H = 6.7 K = 7.0 D <sub>Iso</sub> = 3.9
1-1241408-3	A				SILVER PLATED versilbert						
1241408-1	A				TIN PLATED verzinkt						
1241406-3	A	>2.5-4.0	3.4-4.5	CuNiSi	SILVER PLATED versilbert	4.0	5.2	6.8	19.05	E = 4.6 G = 4.8 D <sub>Dr</sub> = 2.4	H = 6.4 K = 6.7 D <sub>Iso</sub> = 4.0
1241406-1	A				TIN PLATED verzinkt						
1241404-3	A	>1.0-2.5	2.2-3.0	CuNiSi	SILVER PLATED versilbert	3.5	4.7	6.3	19.05	E = 3.8 G = 4.0 D <sub>Dr</sub> = 1.7	H = 4.7 K = 4.9 D <sub>Iso</sub> = 2.6
1241404-1	A				TIN PLATED verzinkt						
1241402-3	A	0.5-1.0	1.4-2.1	CuNiSi	SILVER PLATED versilbert	3.0	4.2	5.8	19.05	E = 2.8 G = 3.0 D <sub>Dr</sub> = 1.1	H = 3.8 K = 4.1 D <sub>Iso</sub> = 1.8
1241402-1	A				TIN PLATED verzinkt						
5-1241400-1	A	0.2-0.5	1.1-1.6	CuNiSi	TIN PLATED verzinkt	2.5	3.8	6.6	19.05	E = 2.2 G = 2.2 D <sub>Dr</sub> = 0.8	H = 3.1 K = 3.1 D <sub>Iso</sub> = 1.4
1241400-1	A				TIN PLATED verzinkt						

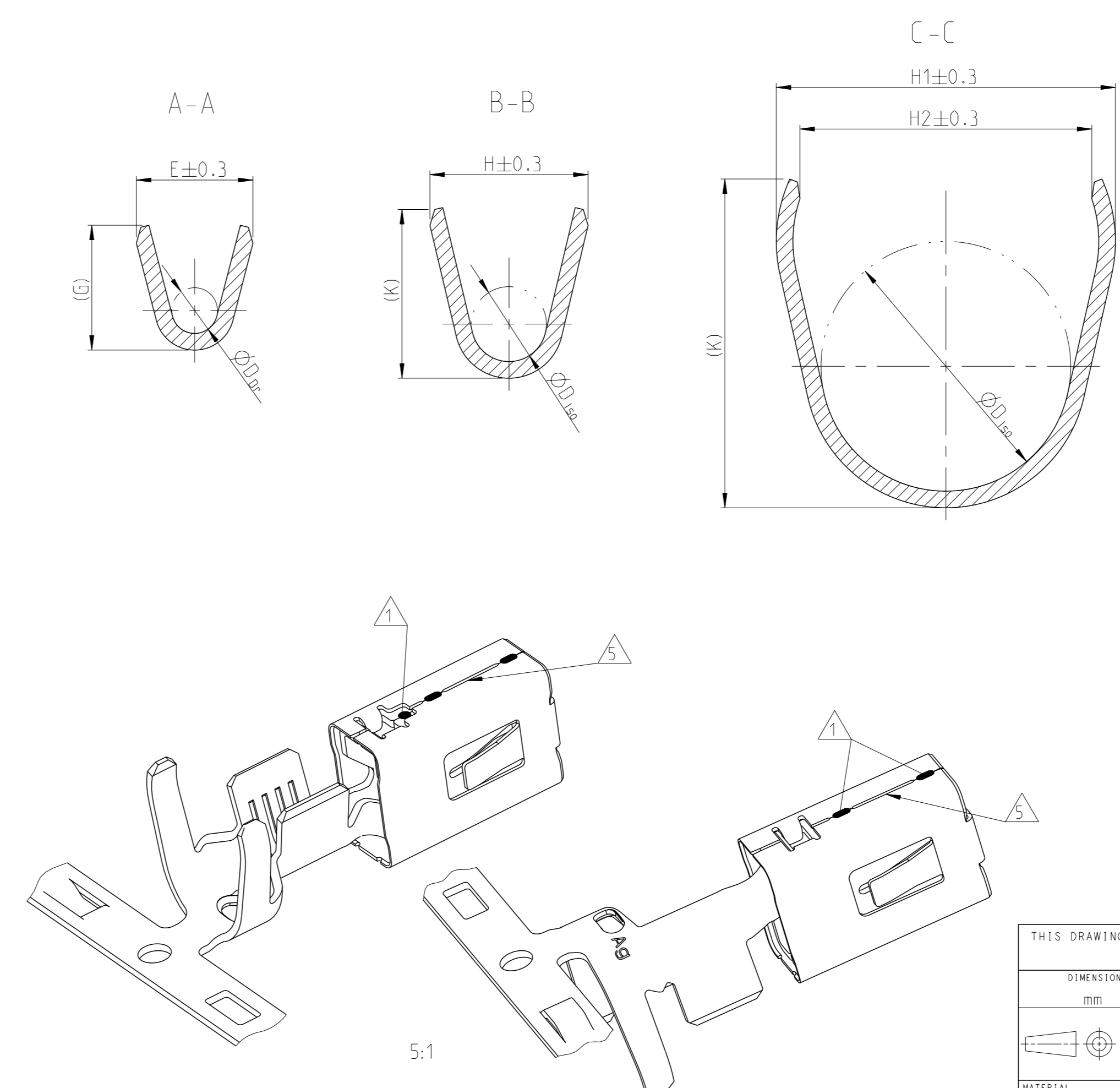

- NOTES Bemerkungen
- 1 LASER WELDED Lasergeschweisst
  - 2 SINGLE WIRE SEAL TO BE SELECTED ACCORDING TO INSULATION-Ø Auswahl der Einzeldichtung entsprechend dem Isolations-Ø
  - 3 DIFFERENT FORM AND NUMBER OF THE SERRATIONS POSSIBLE Unterschiedliche Ausfuehrung und Anzahl der Ritzen moeglich
  - 4 SILVER PLATED VERSIONS ARE MARKED WITH "Ag" Versilberte Versionen sind mit "Ag" gekennzeichnet
  - 5 DIFFERENT ASSEMBLY CAUSED BY PRODUCTION OF THE SPRING ON THE BODY. SPOTWELDS CAN BE ABOVE OR DOWN. Fertigungsbedingte unterschiedliche Montage der Ueberfeder auf dem Body moeglich. Der Stoss kann sich oben oder unten befinden.
  - 6 USED WITH TAB 0.8±0.03mm x 4.8 ... 6.3 ±0.1mm Verwendet mit Flachstecker 0.8±0.03mm x 4.8 ... 6.3 ±0.1mm
  - 7 "Ag" MARKING ON SILVER PLATED VERSIONS FOR INCREASED LIMIT TEMPERATURE "Ag" Markierung auf versilberten Versionen fuer erhoehte Grenztemperatur
  - 8 1241400-1 nicht fuer Neuanwendungen. wird ersetzt durch 5-1241400-1  
1241410-1 nicht fuer Neuanwendungen. wird ersetzt durch 5-1241410-1  
1241410-3 nicht fuer Neuanwendungen. wird ersetzt durch 5-1241410-3  
1241400-1 SUPERSEDED BY PN 5-1241400-1  
1241410-1 SUPERSEDED BY PN 5-1241410-1  
1241410-3 SUPERSEDED BY PN 5-1241410-3

THIS DRAWING IS A CONTROLLED DOCUMENT.		OWN R. Meier 03DEC2001	NAME AMP MCP6.3/4.8K FLATCONTACT AMP MCP6.3/4.8K Flachkontakt PRODUCT GROUP DRAWING
DIMENSIONS: mm		CHK R. Schaefer 03DEC2001	
TOLERANCES UNLESS OTHERWISE SPECIFIED: ±0.2		APVD M. Reichert 28JUL2011	SIZE 110-18388
MATERIAL - FINISH -		WEIGHT -	RESTRICTED TO
Customer Drawing		SCALE 5:1	SHEET 1 OF 2 REV A17

# AMP MCP 6.3/4.8K FOR FUSES AMP MCP 6.3/4.8K fuer Sicherungen

LOC	DIST	REV	DESCRIPTION	DATE	OWN	APVD
A1	-		SEE SHEET 1			

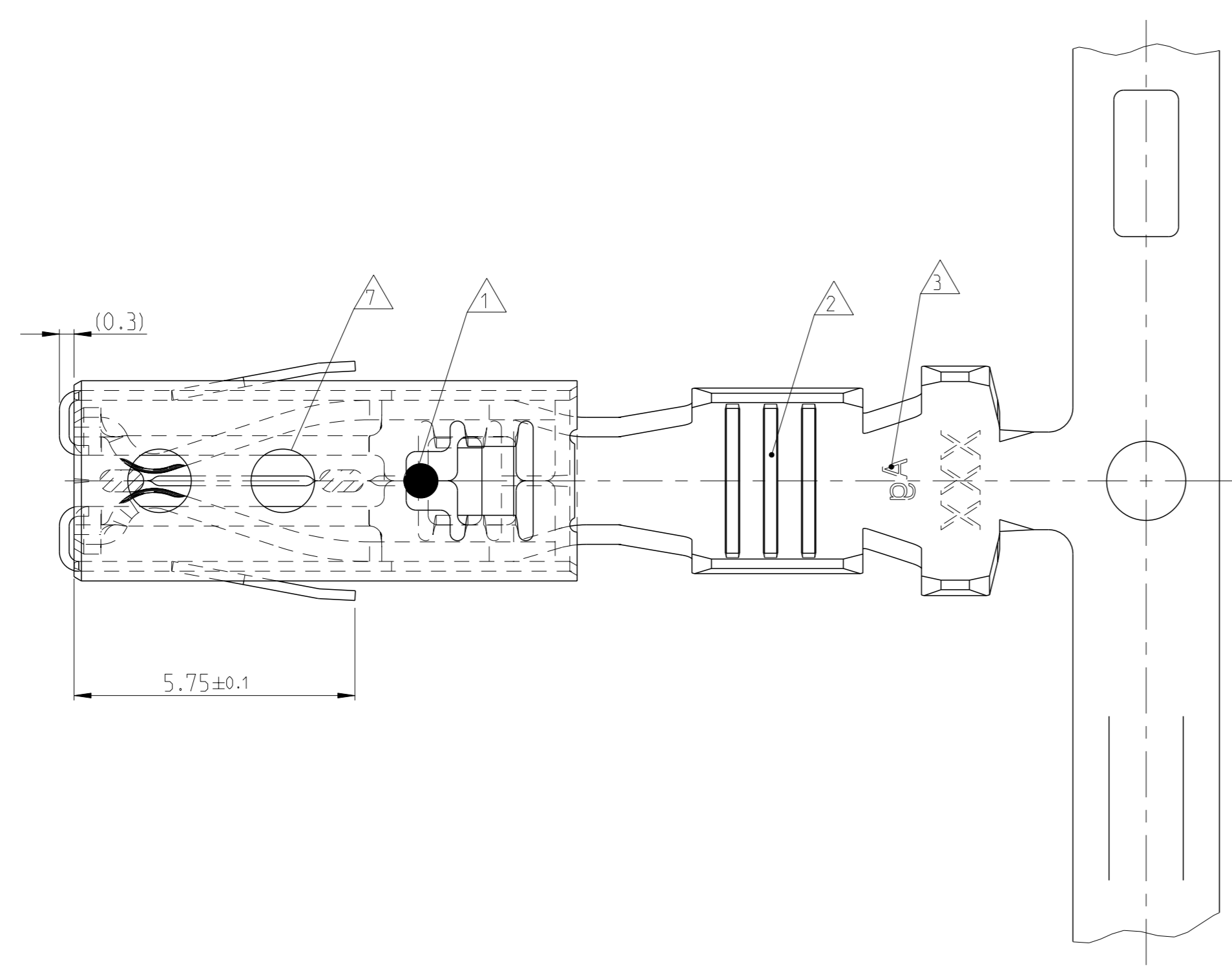
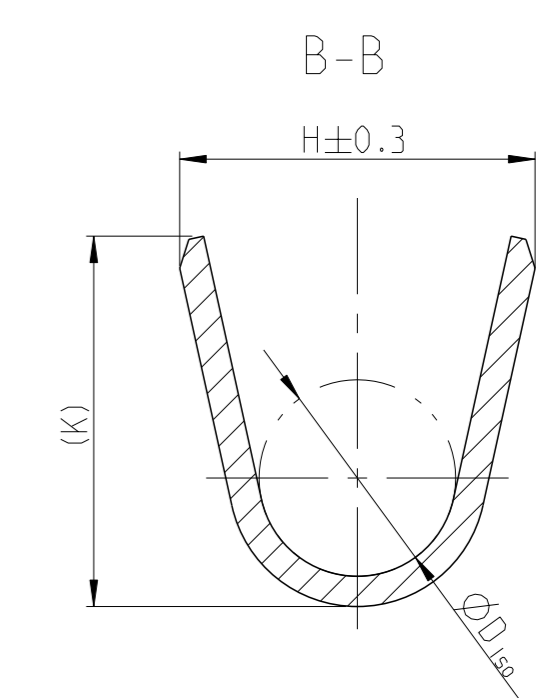
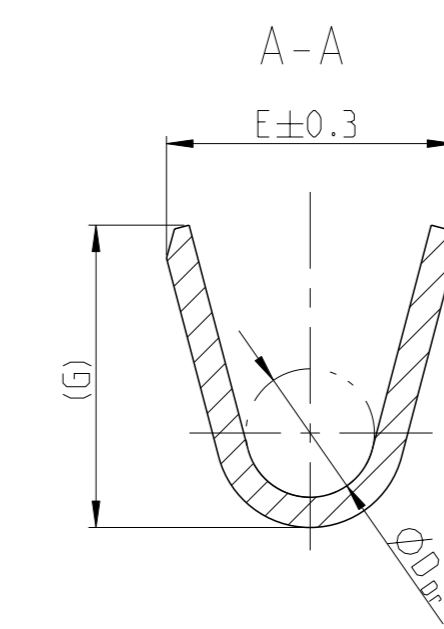
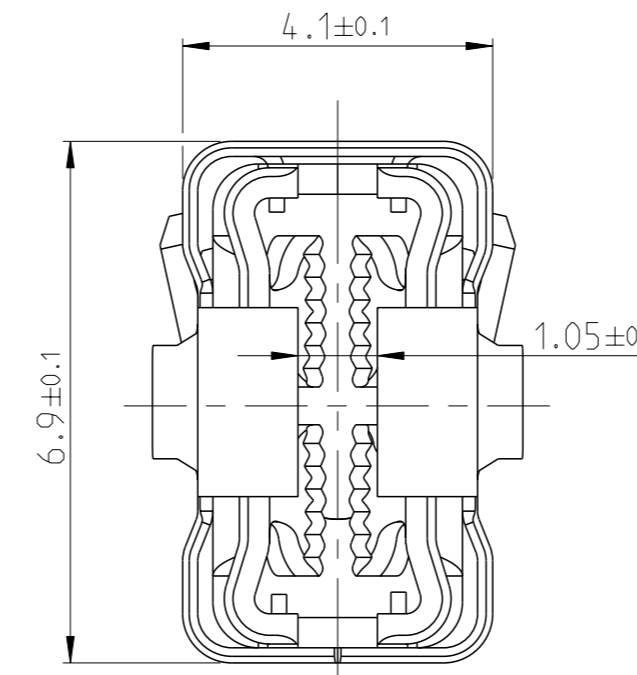
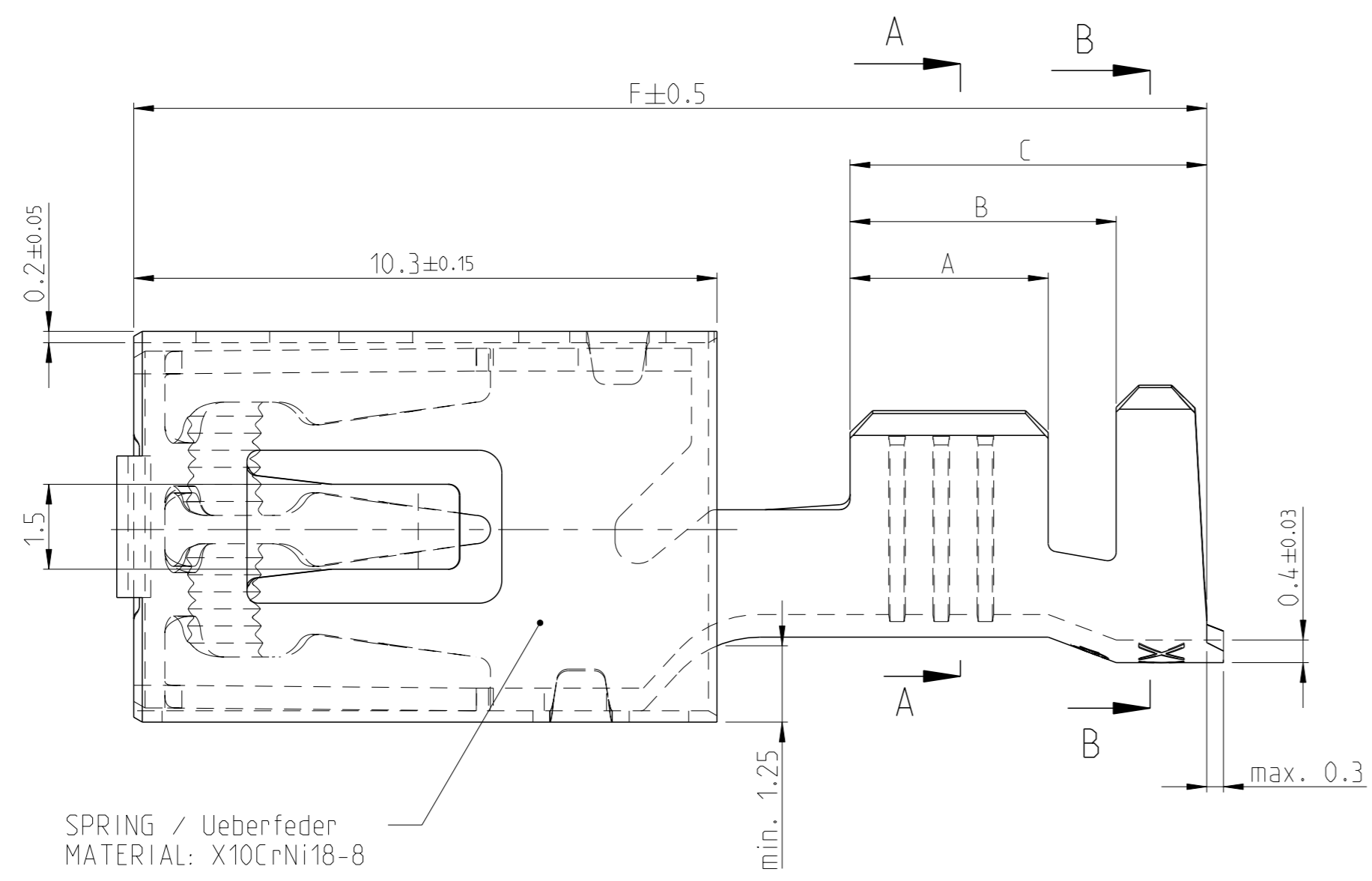

NOTES  
 Bemerkungen

- 1 LASERWELDED  
Lasergeschweisst
- 2 DIFFERENT FORM AND NUMBER OF THE SERRATIONS POSSIBLE  
Unterschiedliche Ausfuehrung und Anzahl der Rillen moeglich
- 3 SILVER PLATED VERSIONS ARE MARKED WITH "Ag"  
Versilberte Versionen sind mit "Ag" gekennzeichnet
- 4 DIFFERENT ASSEMBLY CAUSED BY PRODUCTION OF THE SPRING ON THE BODY.  
SPOTWELDS CAN BE ABOVE OR DOWN.  
Fertigungsbedingte unterschiedliche Montage der Ueberfeder auf dem Body moeglich.  
Der Stoss kann sich oben oder unten befinden.
- 5 USED WITH MEDIUM FUSE  $0.64 \pm 0.04 \text{mm} \times 5.25 \pm 0.15 \text{mm}$   
( COMPLIANT WITH ATO® FUSE TECHNOLOGY )  
ATO® IS A REGISTERED TRADE MARK OF LITTELFUSE INC.  
Verwendet mit Medium Sicherung  $0.64 \pm 0.04 \text{mm} \times 5.25 \pm 0.15 \text{mm}$   
( kompatibel mit ATO®-fuse Technologie )  
ATO® ist ein eingetragener Markenname von Littelfuse Inc.
- 6 USED WITH MaxiCompact FUSE  $0.81 \pm 0.03 \text{mm} \times 6.3 \pm 0.2 \text{mm}$   
MaxiCompact IS A REGISTERED TRADE MARK OF MTA  
Verwendet mit MaxiCompact Fuse  $0.81 \pm 0.03 \text{mm} \times 6.3 \pm 0.2 \text{mm}$   
MaxiCompact ist ein eingetragener Markenname von MTA
- 7 MaxiCompact FUSE VERSIONS ARE MARKED WITH A SECOND HOLE AT THE SPRING  
MaxiCompact Fuse Versionen sind mit einem zweiten Loch in der Ueberfeder gekennzeichnet.

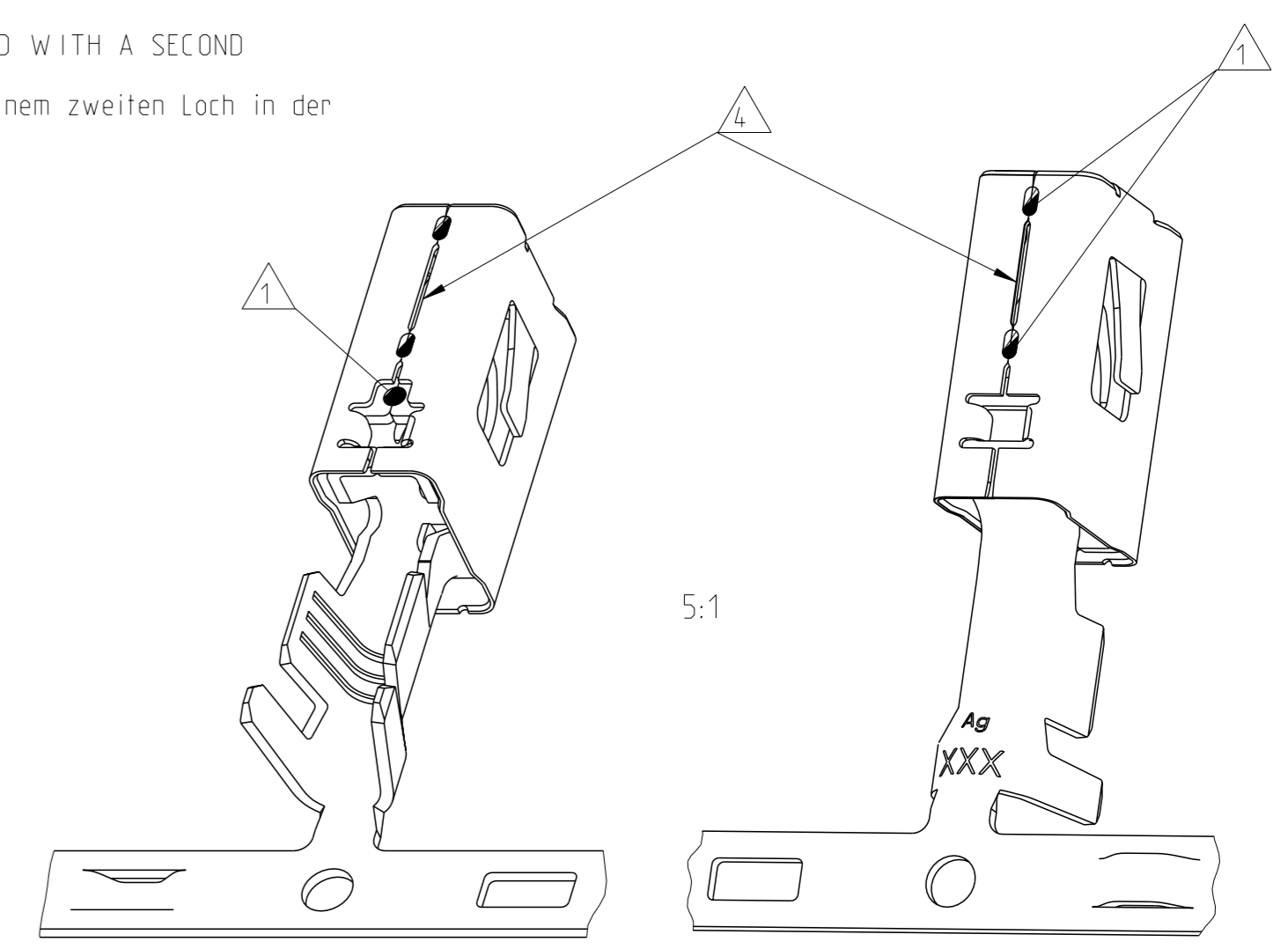

ORDER NO. STRIP Bestell-Nr. Bandware	Rev.	WIRE RANGE Drahtgroessen Bereich (mm 2)	INSULATION- Ø Isolations- Ø (mm)	MATERIAL Werkstoff	SURFACE IN CONTACT AREA Oberflaeche im Kontaktbereich	A	B	C	F	WIRE CRIMP Drahtcrimp	INSULATION CRIMP Isolations Crimp
1-2177995-3	A	>4.0-6.0	4.0-4.3	CuNiSi	SILVER PLATED versilbert	4.5	6.0	7.8	19.95	E = 5.3 G = 5.6 D <sub>Dr</sub> = 2.9	H = 6.7 K = 7.0 D <sub>Iso</sub> = 3.9
1-2333552-3	A	>2.5-4.0	3.3-4.5	CuNiSi	SILVER PLATED versilbert	4.0	5.2	6.8	19.05	E = 4.6 G = 4.8 D <sub>Dr</sub> = 2.4	H = 6.4 K = 6.7 D <sub>Iso</sub> = 4.0
1-2208461-3	A	>1.0-2.5	2.2-3.0	CuNiSi	SILVER PLATED versilbert	3.5	4.7	6.3	19.05	E = 3.8 G = 4.0 D <sub>Dr</sub> = 1.7	H = 4.7 K = 4.9 D <sub>Iso</sub> = 2.6
1-2333551-3	A	0.5-1.0	1.4-2.1	CuNiSi	SILVER PLATED versilbert	3.0	4.2	5.8	19.05	E = 2.8 G = 3.0 D <sub>Dr</sub> = 1.1	H = 3.8 K = 4.1 D <sub>Iso</sub> = 1.8

THIS DRAWING IS A CONTROLLED DOCUMENT.		OWN J. Kirschbaum CHK A. Mairosler	12DEC2013 13DEC2013	TE Connectivity NAME AMP MCP6.3/4.8K FLATCONTACT AMP MCP6.3/4.8K Flachkontakt PRODUCT GROUP DRAWING
DIMENSIONS: mm	TOLERANCES UNLESS OTHERWISE SPECIFIED: ±0.2	APVD C. Goepfel	13DEC2013	
MATERIAL	FINISH	WEIGHT	Customer Drawing	SIZE A1 CAGE CODE 007799 DRAWING NO. ©=1241438
SCALE 10:1			SHEET 2 OF 2	REV. A17