

HIGH EFFICIENCY RECTIFIER
VOLTAGE 1000 Volts CURRENT 1.0 Ampere

FEATURES

- * Low power loss,high efficiency
- * Low leakage
- * Low forward voltage drop
- * High current capability
- * High speed switching
- * High reliability
- * High current surge

MECHANICAL DATA

- * Epoxy: Device has UL flammability classification 94V-O
- * Case: Molded plastic
- * Lead: MIL-STD-202E method 208C guaranteed
- * Mounting position: Any
- * Weight: 0.33 gram
- * Halogen-free

MAXIMUM RATINGS AND ELECTRICAL CHARACTERISTICS

Ratings at 25 °C ambient temperature unless otherwise specified.
Single phase, half wave, 60 Hz, resistive or inductive load.
For capacitive load, derate current by 20%.

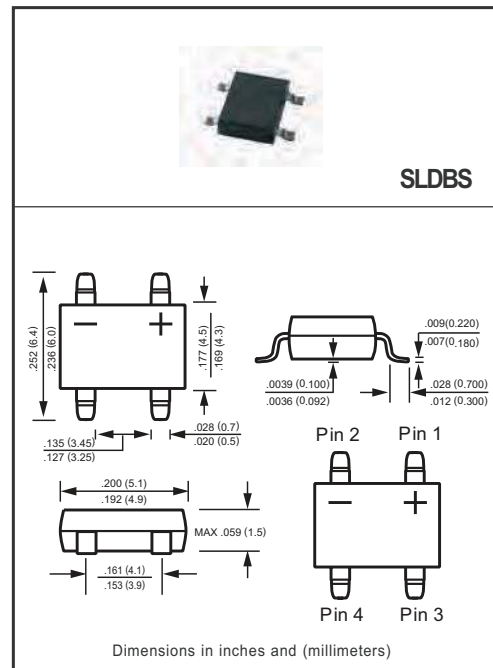

MAXIMUM RATINGS (@ TA=25 °C unless otherwise noted)

RATINGS	SYMBOL	HSLDB108S	UNITS
Maximum Recurrent Peak Reverse Voltage	V _{RRM}	1000	Volts
Maximum RMS Voltage	V _{RMS}	700	Volts
Maximum DC Blocking Voltage	V _{DC}	1000	Volts
Maximum Average Forward Rectified Current at T _A = 50°C	I _O	1.0	Amps
Peak Forward Surge Current 8.3 ms single half sine-wave superimposed on rated load (JEDEC method)	I _{FSM}	30	Amps
Current Squared Time	i ² t	3.7	A ² /Sec
Typical Thermal Resistance (Note 1)	R _{θJL}	18	°C/W
Typical Thermal Resistance (Note 1)	R _{θJA}	60	°C/W
Typical Junction Capacitance (Note 2)	C _J	12	pF
Operating Temperature Range	T _J	150	°C
Storage Temperature Range	T _{STG}	-55 to + 150	°C

ELECTRICAL CHARACTERISTICS (@TA=25 °C unless otherwise noted)

CHARACTERISTICS	SYMBOL	HSLDB108S	UNITS
Maximum Instantaneous Forward Voltage at 1.0A DC	V _F	1.7	Volts
Maximum Average Reverse Current at Rated DC Blocking Voltage	I _R	@T _A = 25°C	0.5
		@T _A = 100°C	100
Maximum Reverse Recovery Time (Note 4)	t _{rr}	75	nSec

- NOTES : 1. Thermal Resistance : At 9.5mm lead length,PCB mounted.
2. Measured at 1 MHz and applied reverse voltage of 4.0 volts.
3. "Fully ROHS compliant", "100% Sn plating (Pb-free)".
4. Test Conditions: I_F= 0.5A, I_R= -1.0A, I_{RR}= -0.25A.

RATING AND CHARACTERISTICS CURVES (HSLDB108S)

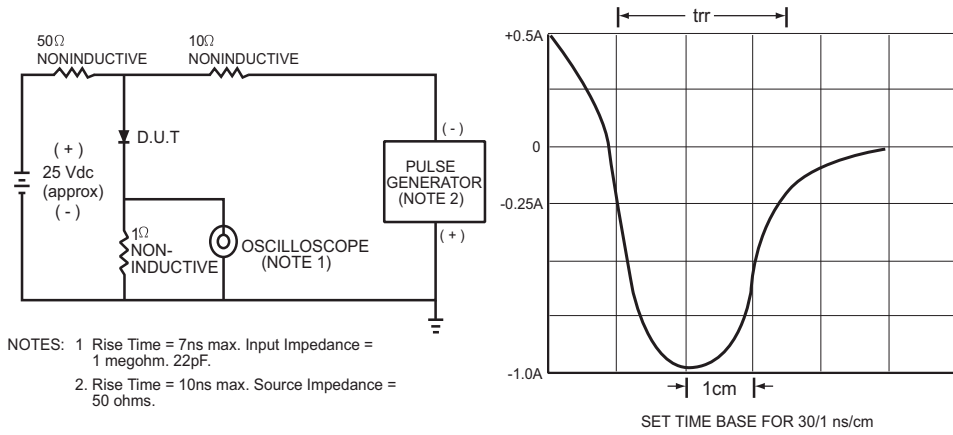

FIG.1 TEST CIRCUIT DIAGRAM AND REVERSE RECOVERY TIME CHARACTERISTIC

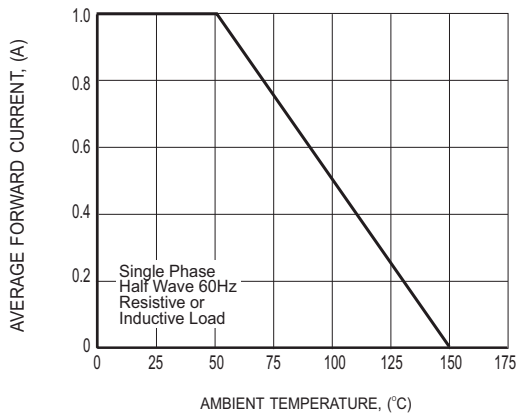

FIG.2 TYPICAL FORWARD CURRENT DERATING CURVE

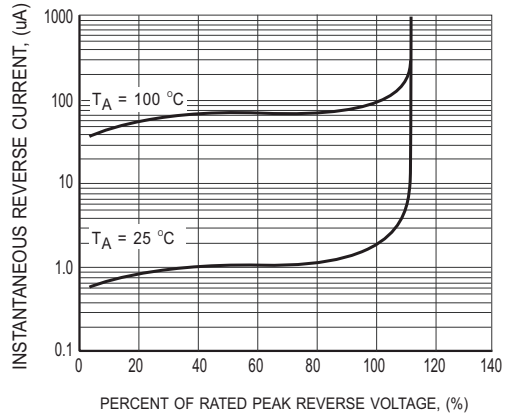

FIG.3 TYPICAL REVERSE CHARACTERISTICS

RATING AND CHARACTERISTICS CURVES (HSLDB108S)

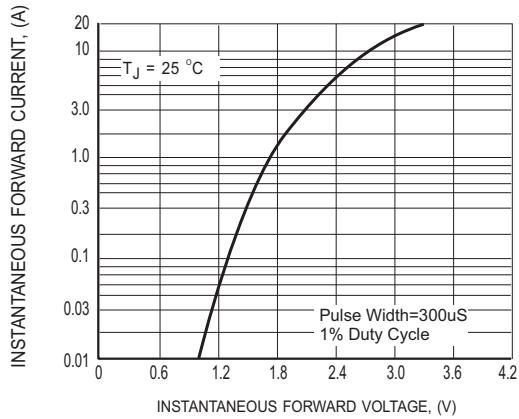

FIG.4 TYPICAL INSTANTANEOUS FORWARD CHARACTERISTICS

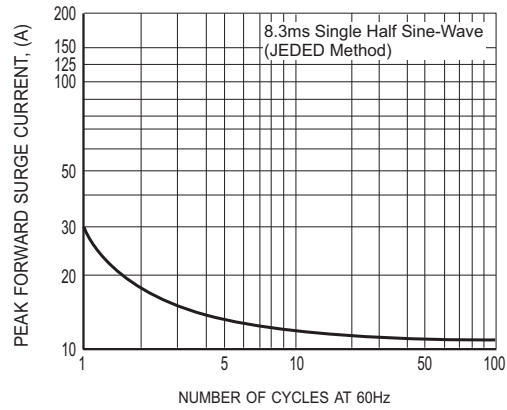

FIG.5 MAXIMUM NON-REPETITIVE FORWARD SURGE CURRENT

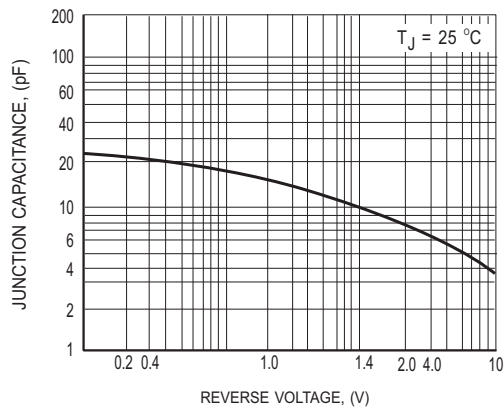
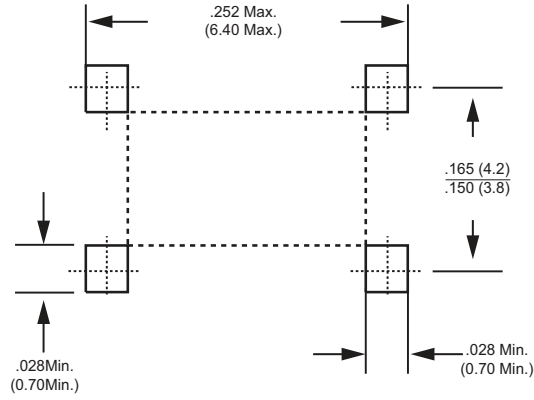

FIG.6 TYPICAL JUNCTION CAPACITANCE

Mounting Pad Layout



Dimensions in inches and (millimeters)

REEL TAPING SPECIFICATIONS FOR SURFACE MOUNT DEVICES-SLDBS

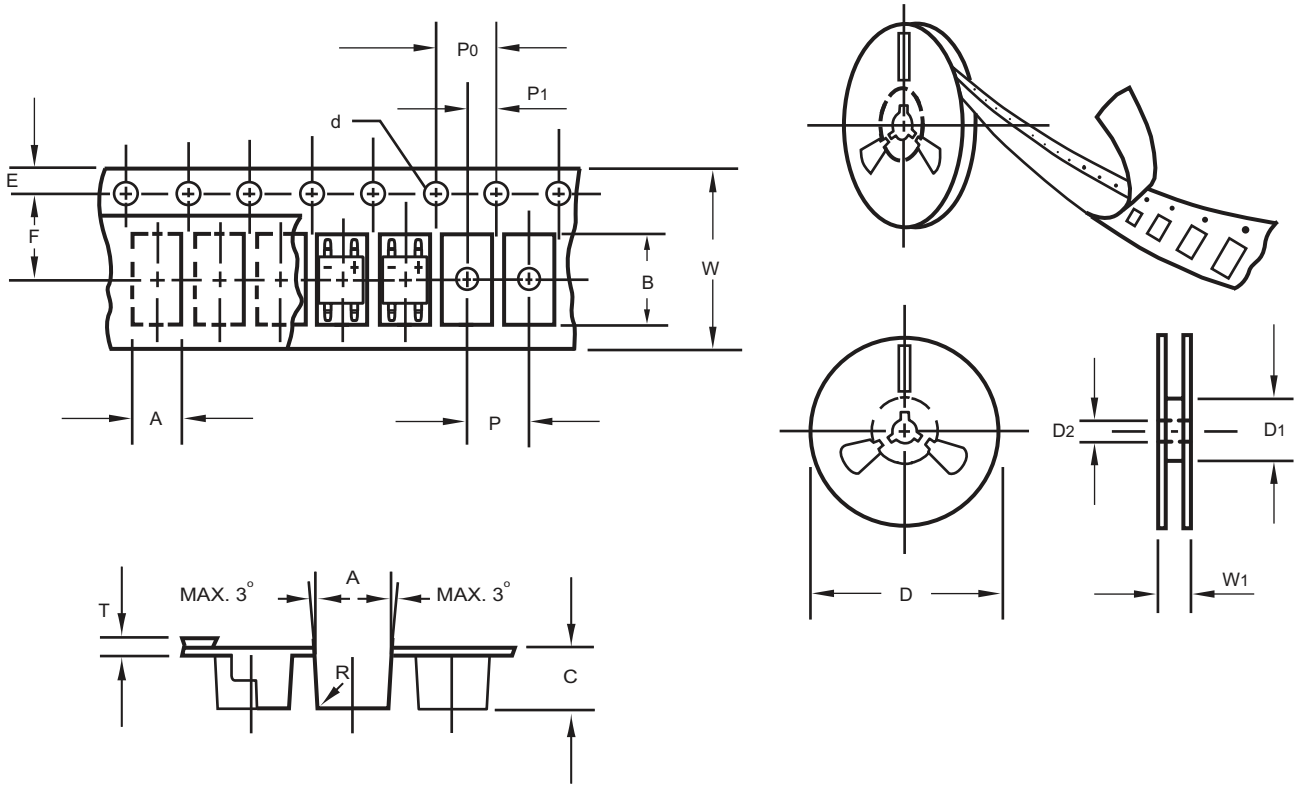
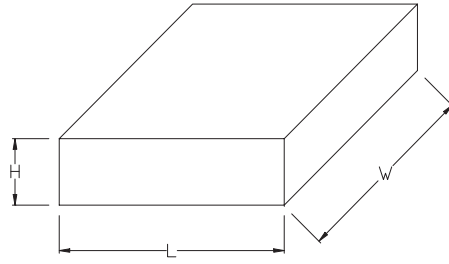

Fig.: Configuration of SLDBS TAPING

ITEM	SYMBOL	SLDBS mm(inch)
Carrier width	A	6.0 ± 0.1 (0.236 ± 0.004)
Carrier length	B	8.30 ± 0.1 (0.327 ± 0.004)
Carrier depth	C	2.5 ± 0.1 (0.098 ± 0.004)
Sprocket hole	d	1.5 ± 0.1 (0.059 ± 0.004)
Reel outside diameter	D	330 ± 2.0 (13.0 ± 0.079)
Reel inner diameter	D1	50 Min.
Feed hole diameter	D2	13 ± 0.5 (0.512 ± 0.020)
Stroket hole position	E	1.5 ± 0.1 (0.059 ± 0.004)
Punch hole position	F	7.65 ± 0.05 (0.301 ± 0.002)
Punch hole pitch	P	8.0 ± 0.1 (0.315 ± 0.004)
Sprocket hole pitch	P0	4.0 ± 0.1 (0.157 ± 0.004)
Embossment center	P1	4.0 ± 0.1 (0.157 ± 0.004)
Totall tape thickness	T	0.6 Max.
Tape width	W	16.0 ± 0.2 (0.630 ± 0.008)
Reel width	W1	24.0 ± 2.0 (0.945 ± 0.079)

Note: 1.Devices are packed in accordance with EIA standard RS-481-A and specification given above.
 2.13 inch (5000 ct.) diameter reels.

1. BOX



Packing Code	L (mm)	W (mm)	H (mm)
-T	340	340	40

2. REEL

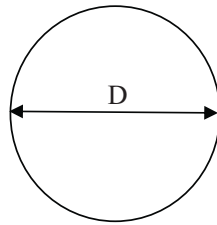

Packing Code	D (mm)
-T	330

3. CARTON

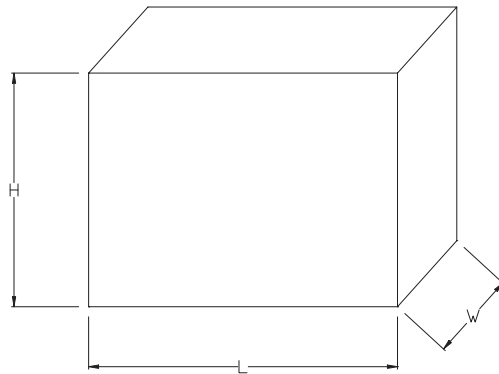

Packing Code	L (mm)	W (mm)	H (mm)
-T	355	360	360

PACKAGING OF DIODE AND BRIDGE RECTIFIERS

REEL PACK

PACKAGE	PACKING CODE	EA PER REEL	EA PER INNER BOX	COMPONENT SPACE (mm)	TAPE SPACE (mm)	REEL DIA (mm)	CARTON SIZE (mm)	EA PER CARTON	GROSS WEIGHT(Kg)
SLDBS	-T/W	5,000	10,000	---	---	330	360*355*360	80,000	16.18

Marking Description

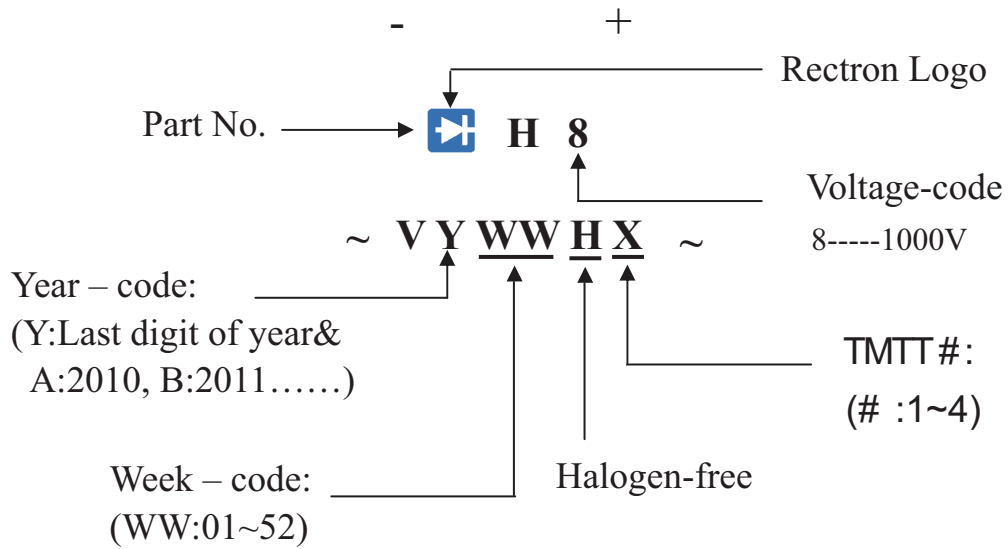

DISCLAIMER NOTICE

Rectron Inc reserves the right to make changes without notice to any product specification herein, to make corrections, modifications, enhancements or other changes. Rectron Inc or anyone on its behalf assumes no responsibility or liability for any errors or inaccuracies. Data sheet specifications and its information contained are intended to provide a product description only. "Typical" parameters which may be included on RECTRON data sheets and/ or specifications can and do vary in different applications and actual performance may vary over time. Rectron Inc does not assume any liability arising out of the application or use of any product or circuit.

Rectron products are not designed, intended or authorized for use in medical, life-saving implant or other applications intended for life-sustaining or other related applications where a failure or malfunction of component or circuitry may directly or indirectly cause injury or threaten a life without expressed written approval of Rectron Inc. Customers using or selling Rectron components for use in such applications do so at their own risk and shall agree to fully indemnify Rectron Inc and its subsidiaries harmless against all claims, damages and expenditures.