

SAM4S-EK Development Board

User Guide





Section 1

Introduction	1-1
1.1 SAM4S Evaluation Kit	1-1
1.2 User Guide	1-1
1.3 References and Applicable Documents	1-1

Section 2

Kit Contents	2-1
2.1 Deliverables	2-1
2.2 Electrostatic Warning	2-2

Section 3

Power Up	3-1
3.1 Power up the Board	3-1
3.2 Sample Code and Technical Support	3-1

Section 4

Evaluation Kit Hardware	4-1
4.1 Board Overview	4-1
4.2 Features List	4-2
4.3 Function Blocks	4-2
4.3.1 Processor	4-2
4.3.2 Memory	4-2
4.3.3 Clock Circuitry	4-3
4.3.4 Reset Circuitry	4-4
4.3.5 Power Supply and Management	4-4
4.3.6 UART	4-5
4.3.7 USART	4-5
4.3.8 RS232	4-6
4.3.9 RS485	4-6
4.3.10 Display Interface	4-6
4.3.11 LCD Module	4-6
4.3.12 Backlight Control	4-7
4.3.13 Touch Screen Interface	4-8
4.3.14 JTAG/ICE	4-8
4.3.15 Audio Interface	4-9
4.3.16 Microphone Input	4-9
4.3.17 USB Device	4-11
4.3.18 Analog Interface	4-11
4.3.19 QTouch Elements	4-12
4.3.20 User Buttons	4-13



4.3.21	LEDs	4-14
4.3.22	SD/MMC Card.....	4-14
4.3.23	ZigBEE.....	4-14
4.3.24	PIO Expansion	4-15
4.4	Configuration.....	4-16
4.4.1	PIO Usage	4-16
4.4.2	Jumpers	4-19
4.4.3	Test Points.....	4-20
4.4.4	Solder Drops.....	4-20
4.4.5	Assigned PIO Lines, Disconnection Possibility.....	4-20
4.5	Connectors.....	4-22
4.5.1	Power Supply Connector J9	4-22
4.5.2	USART Connector J5 With RTS/CTS Handshake Support.....	4-22
4.5.3	UART Connector J7	4-23
4.5.4	USB Device Connector J15	4-23
4.5.5	TFT LCD Connector J8.....	4-24
4.5.6	JTAG Debugging Connector J6.....	4-25
4.5.7	SD/MMC - MCI Connector J3	4-26
4.5.8	Analog Connector CN1 & CN2	4-27
4.5.9	RS485 Connector J14	4-27
4.5.10	Headphone Connector J11	4-28
4.5.11	ZigBEE Connector J16	4-28
4.5.12	PIO Expansion Port C Connector J12	4-29
4.5.13	PIO Expansion Port A Connector J13	4-30
4.5.14	PIO Expansion Port B Connector J14	4-31

Section 5

Schematics	5-1
5.1 Schematics.....	5-1

Section 6

Troubleshooting	6-1
6.1 Board Recovery	6-1

Section 7

Revision History.....	7-1
7.1 Revision History	7-1



Section 1

Introduction

1.1 SAM4S Evaluation Kit

The SAM4S Evaluation Kit (SAM4S-EK) enables evaluation capabilities and code development of applications running on a SAM4S16 device.

1.2 User Guide

This guide focuses on the SAM4S-EK board as an evaluation platform. It is made up of 6 sections:

- Section 1 includes references, applicable documents, acronyms and abbreviations.
- Section 2 describes the kit contents, its main features and specifications.
- Section 3 provides board specifications.
- Section 4 describes the development environment.
- Section 5 provides instructions to power up the SAM4S-EK and describes how to use it.
- Section 6 describes the hardware resources, default jumper and switch settings, and connectors.
- Section 7 provides schematics.
- Section 8 describes the troubleshooting.

1.3 References and Applicable Documents

Table 1-1. References and Applicable Documents

Title	Comment
SAM4S Datasheet	http://www.atmel.com/dyn/resources/prod_documents/11100.pdf





Section 2

Kit Contents

2.1 Deliverables

The Atmel® SAM4S-EK toolkit contains the following items:

- Board:
 - a SAM4S-EK board
 - a universal input AC/DC power supply with US, Europe and UK plug adapters
- Cables:
 - one USB cable
 - one serial RS232 cable
- A Welcome Letter

Figure 2-1. Unpacked SAM4S-EK



Unpack and inspect the kit carefully. Contact your local Atmel distributor, should you have issues concerning the contents of the kit.

2.2 Electrostatic Warning

The SAM4S-EK board is shipped in a protective anti-static package. The board must not be subjected to high electrostatic potentials. A grounding strap or similar protective device should be worn when handling the board. Avoid touching the components or any other metallic element of the board.





3.1 Power up the Board

Unpack the board taking care to avoid electrostatic discharge. Unpack the power supply, select the right power plug adapter corresponding to that of your country, and insert it in the power supply.

Connect the power supply DC connector to the board and plug the power supply to an AC power plug.

The board LCD should light up and display a welcome page. Then, click or touch icons displayed on the screen and enjoy the demo.

3.2 Sample Code and Technical Support

After boot up, you can run some sample code or your own application on the development kit. You can download sample code and get technical support from Atmel website http://www.atmel.com/dyn/products/tools.asp?category_id=163&family_id=605&subfamily_id=2404

Figure 3-1. Atmel Website for AT91SAM Products

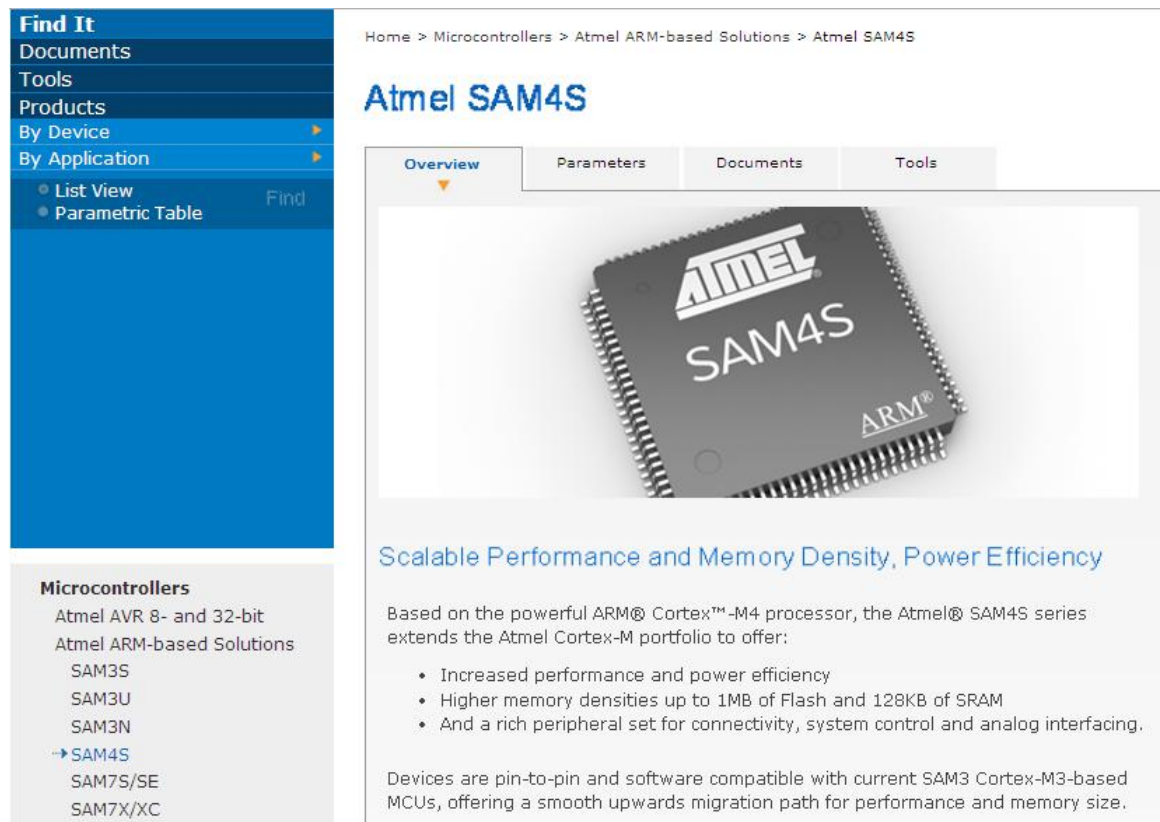

Evaluation Kit Hardware

4.1 Board Overview

This section introduces the Atmel SAM4S Evaluation Kit design. It introduces system-level concepts, such as power distribution, memory, and interface assignments.

The SAM4S-EK board is based on the integration of an ARM® Cortex®-M3 processor with on-board NAND Flash and a set of popular peripherals. It is designed to provide a high performance processor evaluation solution with high flexibility for various kinds of applications.

Figure 4-1. SAM4S-EK Block Diagram

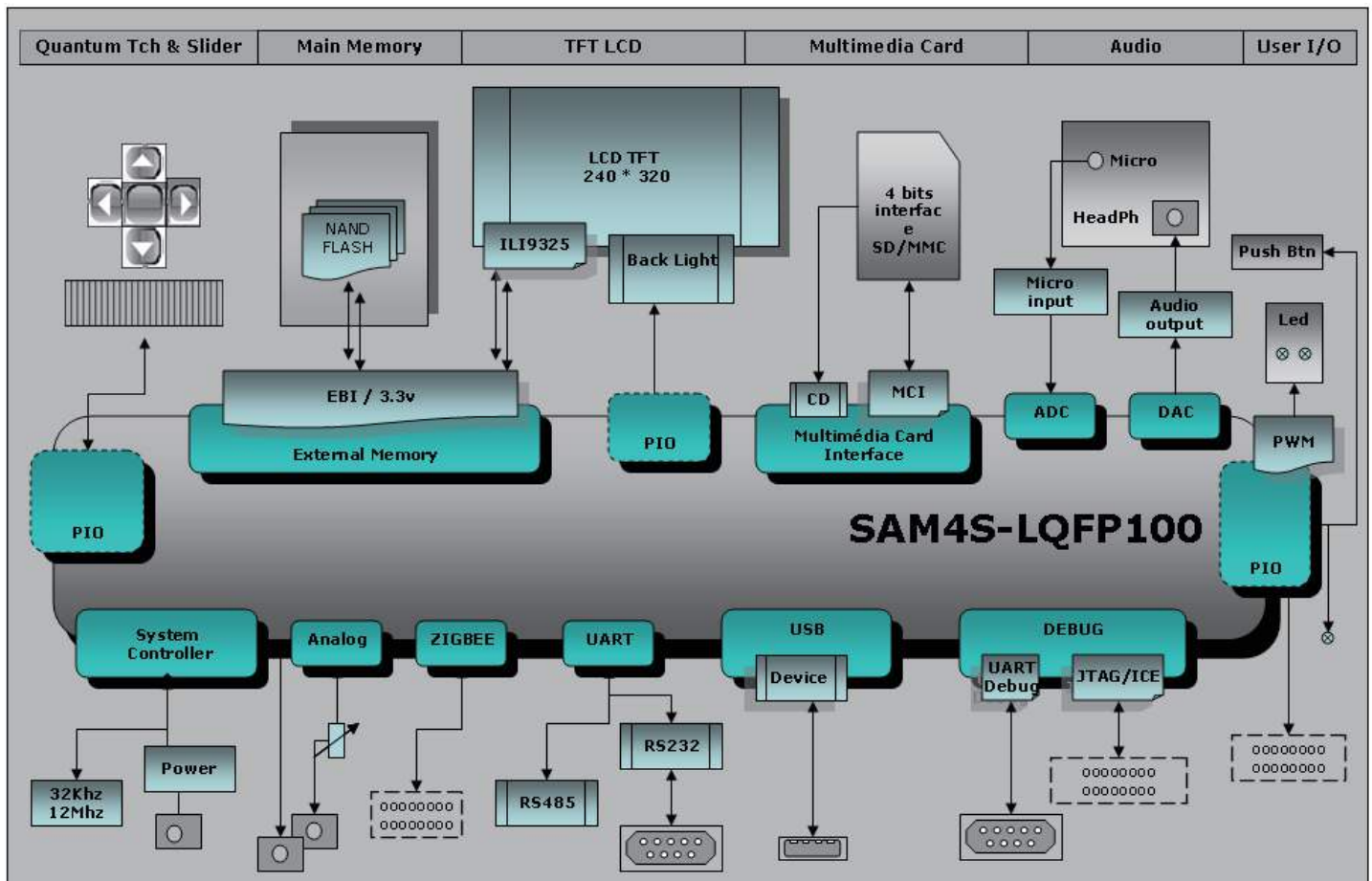

4.2 Features List

Here is the list of the main board components and interfaces:

- SAM4S16 chip LQFP100 package with optional socket footprint
- 12 MHz crystal
- 32.768 KHz crystal
- Optional SMB connector for external system clock input
- NAND Flash
- 2.8 inch TFT color LCD display with touch panel and backlight
- UART port with level shifter circuit
- USART port with level shifter circuit multiplexed with RS485 port with level shifter circuit
- Microphone input and mono/stereo headphone jack output
- SD/MMC interface
- Reset button: NRST
- User buttons: Left and Right
- QTouch[®] buttons: Up, Down, Left, Right, Valid and Slider
- Full Speed USB device port
- JTAG/ICE port
- On-board power regulation
- Two user LEDs
- Power LED
- BNC connector for ADC input
- BNC connector for DAC output
- User potentiometer connected to the ADC input
- ZigBEE connector
- 2x32 bit PIO connection interfaces (PIOA, PIOC) and 1x16 bit PIO connection interface (PIOB)

4.3 Function Blocks

4.3.1 Processor

The SAM4S-EK is equipped with a SAM4S16 device in LQFP100 package.

4.3.2 Memory

The SAM4S16 chip embeds:

- 1024 Kbytes of embedded Flash
- 128 Kbytes of embedded SRAM
- 16 Kbytes of ROM with embedded BootLoader routines (UART, USB) and In-Application Programming functions (IAP) routines.



The SAM4S chip internally generates the following clocks:

- SLCK, the Slow Clock, which is the only permanent clock of the system
- MAINCK, the output of the Main Clock Oscillator selection: either a Crystal Oscillator or a 4/8/12 MHz Fast RC Oscillator
- PLLACK, the output of the Divider and 60 to 130 MHz programmable PLL (PLLA)
- PLLBCK, the output of the Divider and 60 to 130 MHz programmable PLL (PLLB)

4.3.4 Reset Circuitry

On-board NRST button BP1 provides an external reset control of the SAM4S.

The NRST pin is bidirectional. It is handled by the on-chip reset controller. It can be driven low to provide a reset signal out to the external components. Conversely, it can be asserted low from the outside to reset the microcontroller Core and the peripherals. The NRST pin integrates a permanent pull-up resistor of about 100 kOhm to VDDIO.

On the SAM4S-EK board, the NRST signal is connected to the LCD module and JTAG port.

Note: At power-on, the NRST signal is asserted with a default duration of 2 clock cycles. That duration may not be sufficient to correctly reset any other system or board devices connected to that signal. First, in your custom application, you need to check for these devices' datasheets about reset duration requirements. Then, you need to set an appropriate configuration in the NRST Manager. This is done through the ERSTL field in the RSTC_MR register. The NRST duration is thereby configurable between 60 μ s and 2 s, whether it is subsequently activated by a software reset or a user reset. Refer to the SAM4S datasheet for in depth information.

4.3.5 Power Supply and Management

The SAM4S-EK board is supplied with an external 5V DC block through input J9. It is protected by a PolyZen diode MN9 and an LC combinatory filter MN10. The PolyZen is used in the event of an incorrect power supply connection.

The adjustable LDO regulator MN12 is used for the 3.3V rail main supply. It powers all the 3.3V components on the board.

Figure 4-4. Power Block

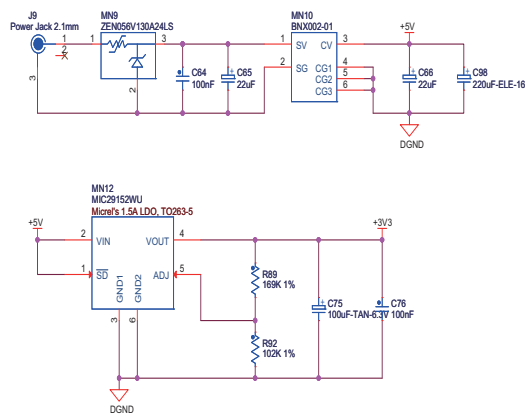

The SAM4S product series has different types of power supply pins:

- VDDIN pin:
Power for the internal voltage regulator, ADC, DAC, and analog comparator power supplies.
The voltage ranges from 1.8V to 3.6V.



- VDDIO pins:
Power for the Peripherals I/O lines.
The voltage ranges from 1.62V to 3.6V.
 - VDDOUT pin:
Output of the internal voltage regulator.
 - VDDCORE pins:
Power for the core, including the processor, embedded memories and peripherals.
The voltage ranges from 1.62V to 1.95V.
 - VDDPLL pin:
Power for the PLL A, PLL B and 12 MHz oscillator.
The voltage ranges from 1.62V to 1.95V.
- Note:** VDDPLL should be decoupled and filtered from VDDCORE.

4.3.6 UART

The Universal Asynchronous Receiver Transmitter features a two-pin UART that can be used for communication and trace purposes. It offers an ideal channel for in-situ programming solutions. This UART is associated with two PDC channels to reduce the processor time on packet handling.

This two-pin UART (TXD and RXD only) is buffered through an RS232 Transceiver MN6 and brought to the DB9 male connector J7.

Figure 4-5. UART

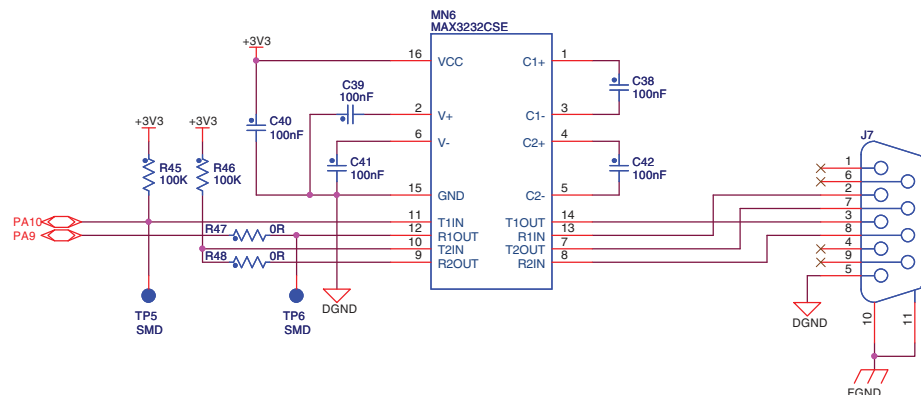

4.3.7 USART

The Universal Synchronous/Asynchronous Receiver Transmitter (USART) provides one full duplex universal synchronous/asynchronous serial link. The data frame format is extensively configurable (data length, parity, number of stop bits) to support a broad range of serial communication standards. The USART is also associated with PDC channels for TX/RX data access.

Note: For design optimization purposes, both transmitters have been implemented on the same PIO lines, that is PA21, 22, 23, 24 25.

To avoid any electrical conflict, the RS485 transceiver is isolated from the receiving line PA21.

Should you need to implement an RS485 channel in place of the RS232, follow the procedure below:

1. make sure your software will permanently set PA23 to a high level - this will permanently disable the RS232 receiver.
2. solder a shunt resistor in place of R25 (a solder drop will do).



4.3.8 RS232

SAM4S-EK connects the USART1 bus (including TXD, RXD, RTS, CTS handshake signal controls and EN command) to the DB9 male connector J5 through the RS232 Transceiver MN5.

Figure 4-6. USART

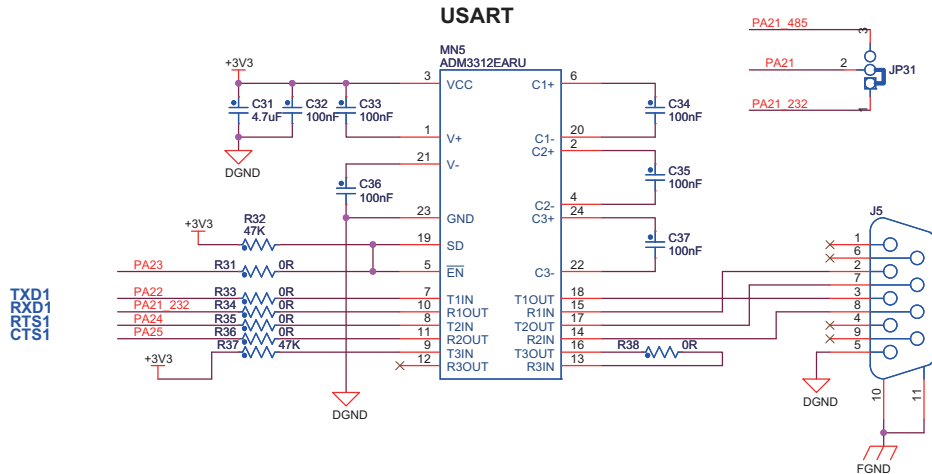

4.3.9 RS485

As noticed above, the USART1 is shared with the RS485 port, connected to the transceiver MN4, connected to the 3-point connector J4. The design includes selectable jumpers for RS485 bus termination resistors selection (JP10, JP11, JP12).

Figure 4-7. RS485

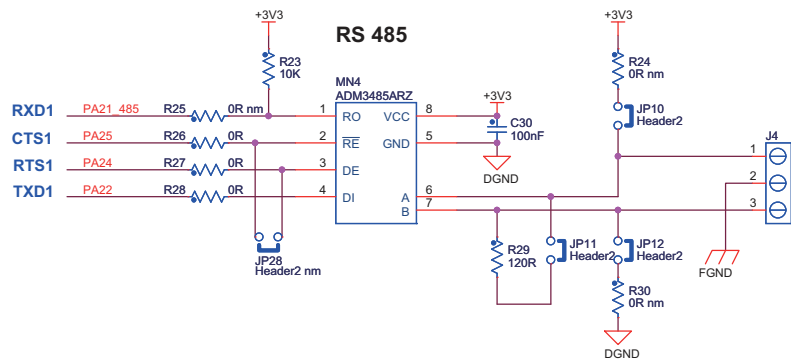

4.3.10 Display Interface

The SAM4S-EK carries a TFT Transmissive LCD module with touch panel, FTM280C34D. Its integrated driver IC is ILI9325. The LCD display area is 2.8 inches diagonally measured, with a native resolution of 240 x 320 dots.

4.3.11 LCD Module

The LCD module gets reset from the NRST signal. As explained, this NRST is shared with the JTAG port and the push-button BP1. The LCD chip select signal is connected to NCS1; the jumper JP13 can disconnect it so that this PIO line is available for other custom usage.

The SAM4S communicates with the LCD through PIOC where an 8-bit parallel “8080-like” protocol data bus has to be implemented by software.



Figure 4-8. LCD Block

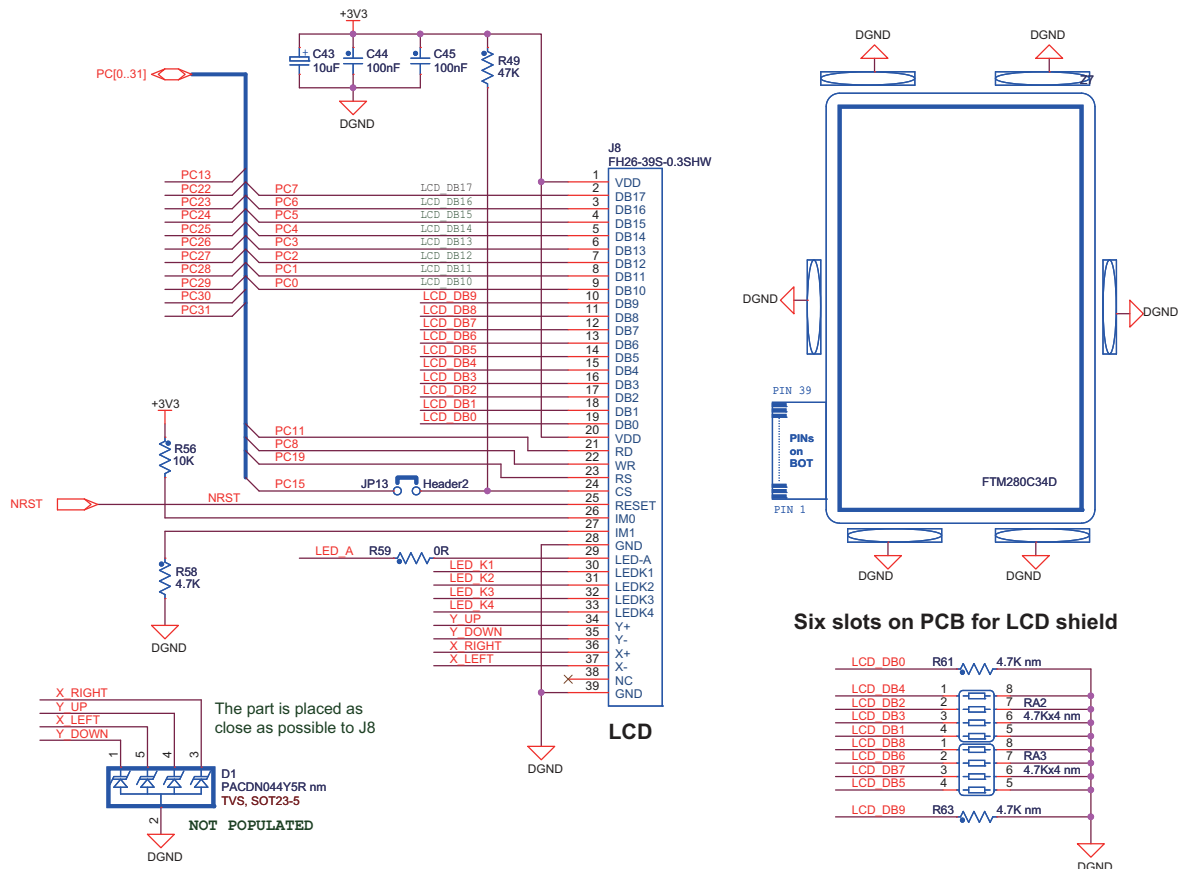

4.3.12 Backlight Control

The LCD backlight is made of four integrated white chip-LEDs arranged in parallel. These are driven by an AAT3155 charge pump, MN8. The AAT3155 is controlled by the SAM4S through a single PIO line PC13 interface; the 0 Ohm resistor R68 is mounted in series on this line, which permits to use it for other custom purposes. In that case, the pull-up resistor R64 maintains the charge pump permanently enabled by default.

On the anode drive line, a 0 Ohm resistor R59 is implemented in series for an optional current limitation.

Figure 4-9. Backlight Control

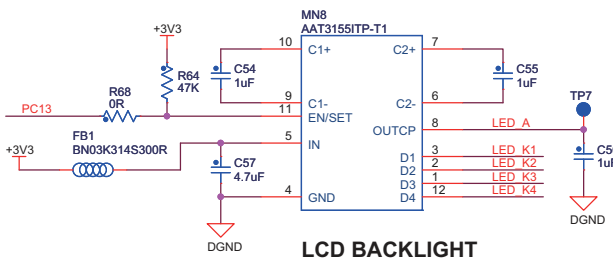

4.3.13 Touch Screen Interface

The LCD module integrates a 4-wire touch panel controlled by MN7 (ADS7843) which is a slave device on the SAM4S SPI bus. The controller sends back the information about the X and Y positions, as well as a measurement for the pressure applied to the touch panel. The touch panel can be used with either a stylus or a finger.

The ADS7843 touch panel controller connects to the SPI0 interface via the NPCS0 control signal. Two interrupt signals are connected and provide events information back to the microcontroller: PenIrq and Busy.

- Note:** PenIrq (PA16) is shared with ZigBEE signal IRQ0.
 Busy (PA17) is shared with ZigBEE signal IRQ1.
 Therefore, if using a ZigBEE interface in concurrence with the TouchScreen controller, take care not to have both drivers enabled at the same time on either PA16 or PA17.

For that purpose, 0 Ohm resistors have been implemented on these PIO lines in order to disconnect either end driver from the other:

- On the touch panel controller side, R67 and R69.
- On ZigBEE side, R117 and R120.

for further information, refer to the “Schematics” section.

Touch ADC auxiliary inputs IN3/IN4 of the ADS7843 are connected to test point (TP8, TP9) for optional function extension.

Figure 4-10. Touch Panel Control

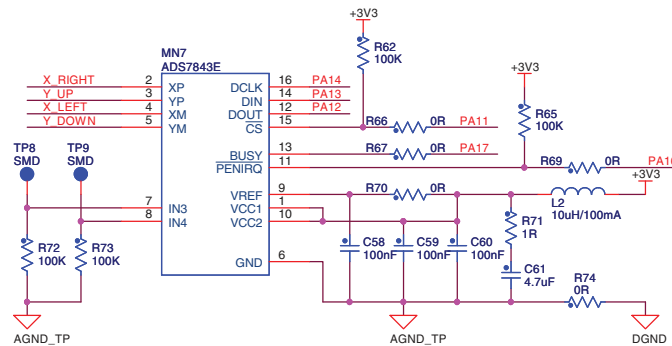

4.3.14 JTAG/ICE

A standard 20-pin JTAG/ICE connector is implemented on the SAM4S-EK for the connection of a compatible ARM JTAG emulator interface, such as the SAM-ICE from Segger.

- Notes:**
1. The NRST signal is connected to BP1 system button and is also used to reset the LCD module. The 0 ohm resistor R44 may be removed in order to isolate the JTAG port from this system reset signal.
 2. The TDO pin is in input mode with the pull-up resistor disabled when the Cortex M3 is not in debug mode. To avoid current consumption on VDDIO and/or VDDCORE due to floating input, the internal pull-up resistor corresponding to this PIO line must be enabled.



Figure 4-11. JTAG Interface

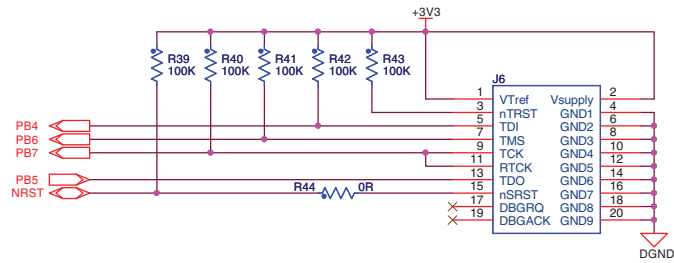

4.3.15 Audio Interface

The SAM4S-EK board supports both audio recording and playback.

The audio volume can be adjusted using the potentiometer RV1, and the microphone amplifier gain can be adjusted via jumpers (fixed gain of 24 or 26 dB).

4.3.16 Microphone Input

The embedded microphone is connected to an audio pre-amplifier using the TS922 operational amplifier (MN11). The gain is set by using JP14 and JP15 jumpers; both must be set or removed at the same time.

By modifying the jumper positions, you can select each of the following gain values:

- 20 dB (default setting, both JP14 and JP15 are off)
- 26 dB (both JP14 and JP15 are on).

Note:

3. The TB1 series 0 Ohm resistor is a reservation for future impedance adaptation facility. Under specific amplifier settings conditions, this enables the easy insertion of a capacitor or any other bipolar device on the audio path. On the other hand, R83 is a default 0 Ohm resistor that enables the disconnection of PB0 from the audio input path for custom usage.
4. The audio pre-amplifier MN11 is powered by a dedicated low dropout regulator MIC5219-3.3 (MN14).



Figure 4-12. Microphone Input

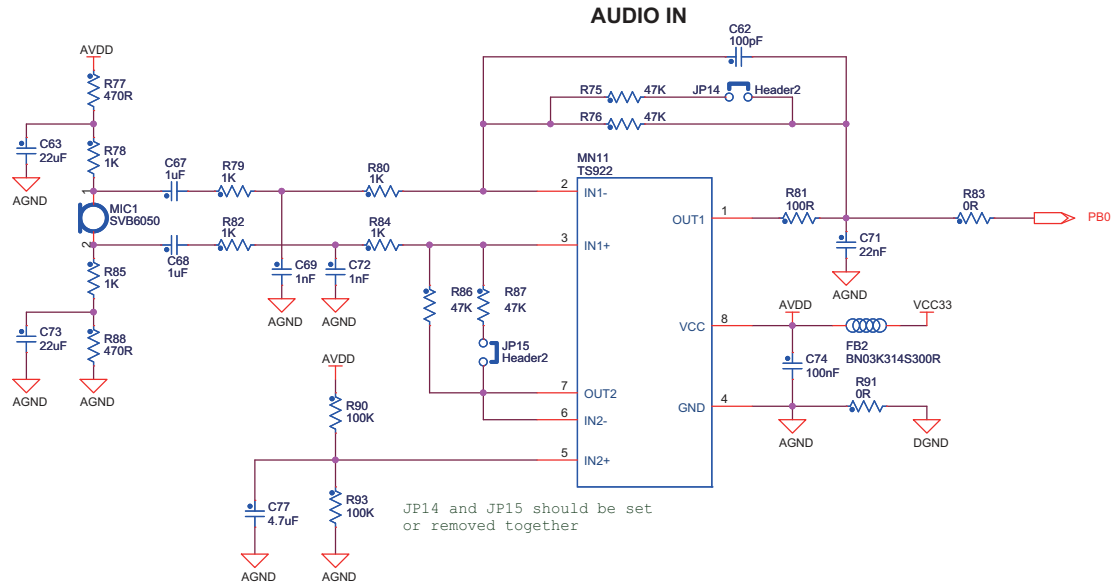

4.3.16.1 Headphone Output

The SAM4S-EK evaluation kit supports mono/stereo audio playback driven by a TPA0223 audio amplifier connected to two DAC channels of the microcontroller.

The TPA0223 is a 2W mono Bridge-Tied-Load (BTL) amplifier designed to drive speakers with as low as 4 Ohm impedance. The amplifier can be reconfigured on the fly to drive two stereo Single-Ended (SE) signals into headphones.

Figure 4-13. Headphone Output

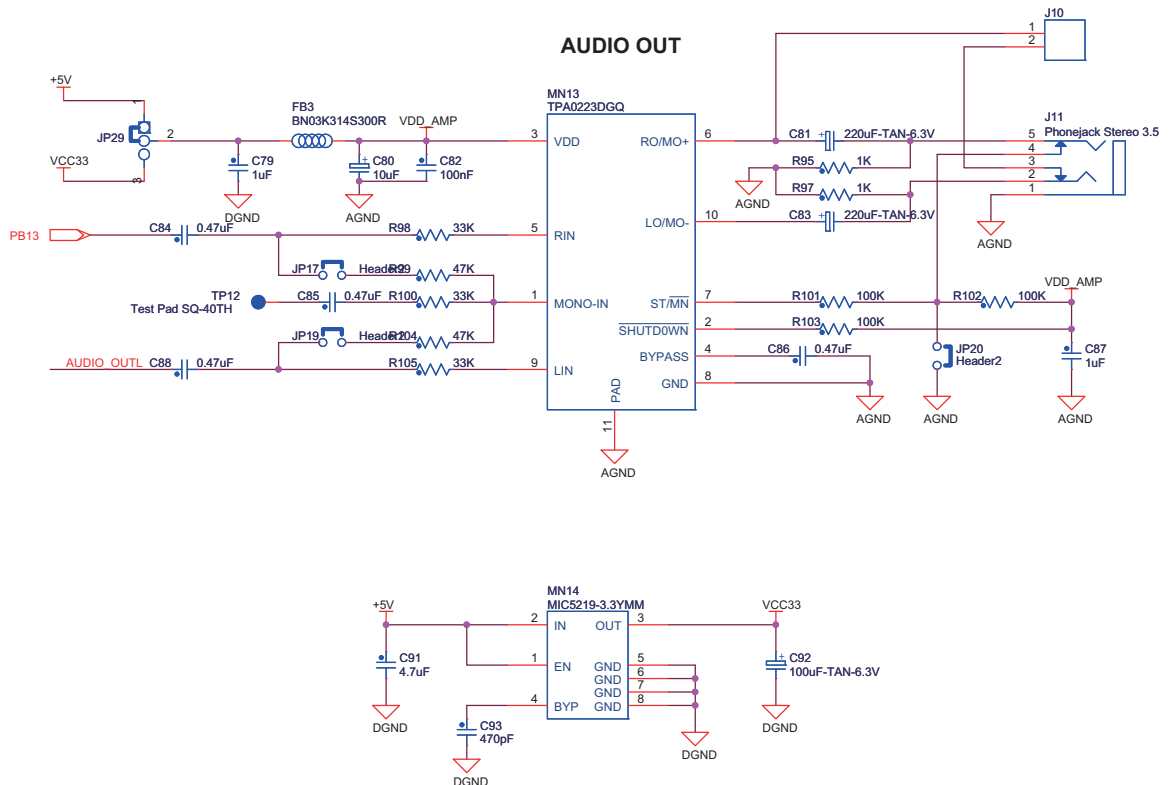

Using a readily available 1/8-in. (3,5 mm) stereo headphone jack, the control switch is closed when no plug is inserted. When closed, a 100-kOhm/1-kOhm divider pulls the ST/MN input low. When a jack plug is inserted, the 1-kOhm resistor is disconnected and the ST/MN input is pulled high. The mono speaker (J10 connector) is also physically disconnected from the RO/MO+ output so that no sound is heard from the speaker while the headphones are inserted.

4.3.17 USB Device

The SAM4S UDP port is compliant with the Universal Serial Bus (USB) rev 2.0 Full Speed device specification. J15 is a micro B-type receptacle for USB device.

Both 27-Ohm resistors R114 and R116 build up a 90-Ohm differential impedance together with the (embedded) 6-Ohm output impedance of the SAM4S full speed channel drivers.

R110 and R112 build up a divider bridge from VBUS +5V to implement plug-in detection (5V level gets lowered to a PIO compatible 3.3V level) through PC21.

Figure 4-14. USB

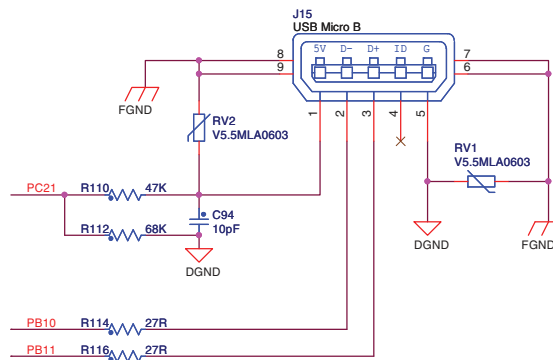

4.3.18 Analog Interface

4.3.18.1 Analog Reference

The 3V voltage reference is based on an LM4040 (Precision Micropower Shunt Voltage Reference). This ADVREF level can be set as 3V or 3.3V via the jumper JP2.

Figure 4-15. Analog Vref

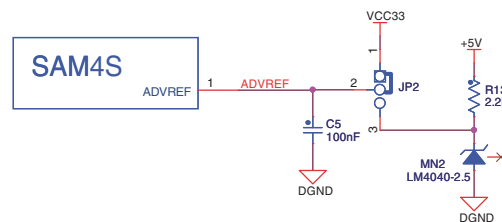

4.3.18.2 Analog Input

The BNC connector CN1 is connected to the ADC port PB1 as an external analog input. An on-board 50-Ohm resistor termination can be applied by closing jumper JP16. A low pass filter can be implemented for the BNC connector CN1 by replacing R94 and C78 with custom resistor and capacitor values, depending on your application requirements.

A 10-KOhm potentiometer (VR1) is also connected to this channel to implement an easy access to ADC programming and debugging (or implement an analog user control like display brightness, volume, etc.).

Either of these two functions can be selected by jumper JP18.

Figure 4-16. ADC Input

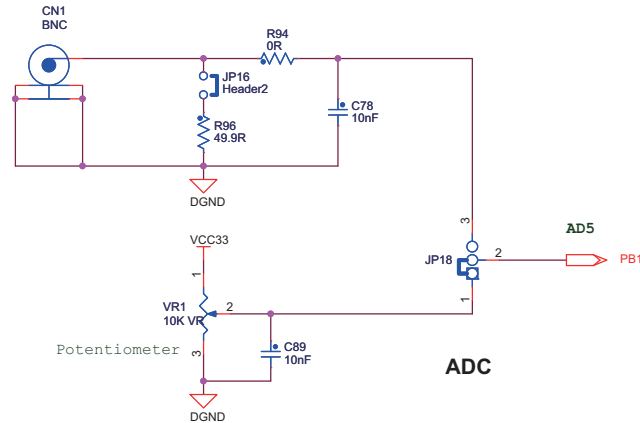

4.3.18.3 Analog Output

The BNC connector CN2 is connected to the DAC port PB14 and provides an external analog output. An on-board 50-Ohm resistor termination can be enabled by closing jumper JP21. A filter can be implemented on this output channel by replacing R106 and C90 with appropriate resistor and capacitor values, depending on the application requirements.

Figure 4-17. DAC Output

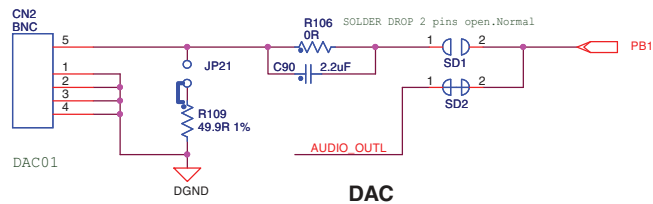

4.3.19 QTouch Elements

QTouch keys consist in a series of sensors formed by the association of a copper area and the capacitive effect of human fingers approaching it.

4.3.19.1 Keys

The SAM4S-EK implements five individual capacitive touch keys (UP, DOWN, RIGHT, LEFT and VALID) using five pairs of PIO.



Figure 4-18. QST Keys

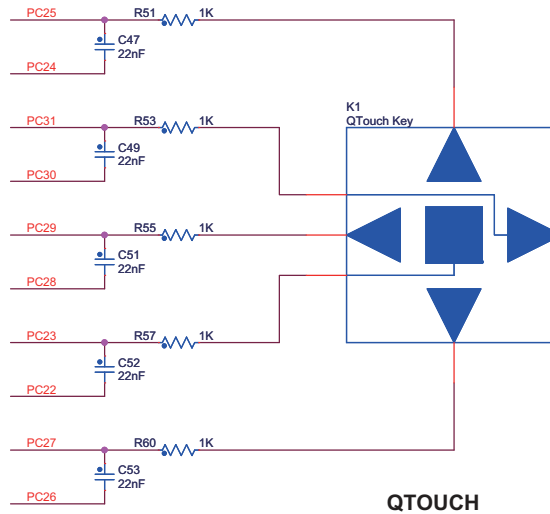

4.3.19.2 Slider

A group of channels forms a Slider. A Slider is composed of three channels for a QTouch acquisition method using three pairs of PIO. Such a sensor is used to detect a linear finger displacement on a sensitive area. A typical implementation is volume control.

Figure 4-19. QT_Slider

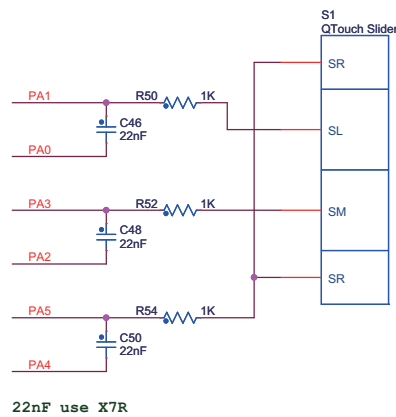

4.3.20 User Buttons

There are two mechanical user buttons on the SAM4S-EK, which are connected to PIO lines and defined to be "left" and "right" buttons by default.

In addition, a mechanical button controls the system reset, signal NRST.

Figure 4-20. System Buttons

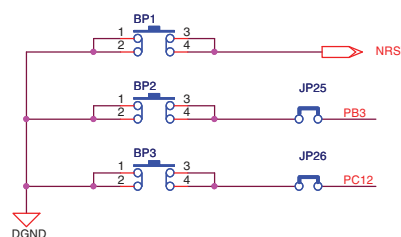

4.3.21 LEDs

There are three LEDs on the SAM4S-EK board:

- A blue LED (D2) and a green LED (D3), which are user defined and controlled by the GPIO.
- A red LED (D4), which is a power LED indicating that the 3.3V power rail is active. It is also controlled by the GPIO and can be treated as a user LED as well. The only difference with the two others is that it is controlled through a MOS transistor. By default, the PIO line is disabled; a pull-up resistor controls the MOS to light the LED when the power is ON).

Figure 4-21. LEDs

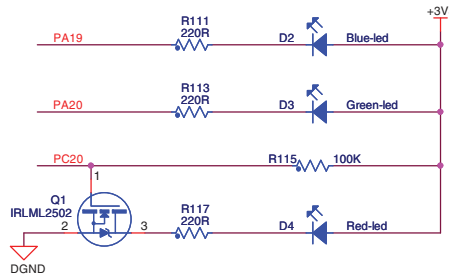

4.3.22 SD/MMC Card

The SAM4S EK has a high-speed 4-bit multimedia MMC interface, which is connected to a 4-bit SD/MMC micro card slot featuring a card detection switch.

Figure 4-22. SD Card

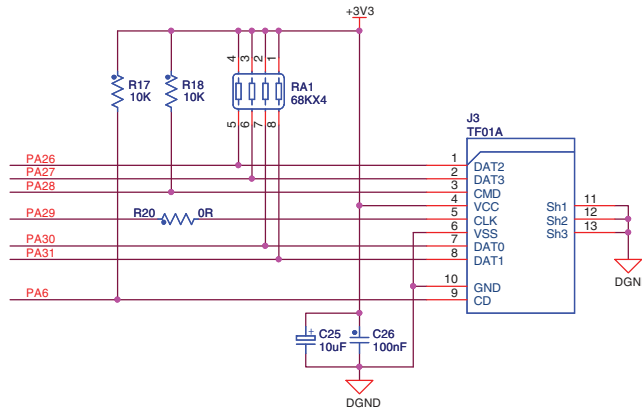

4.3.23 ZigBEE

SAM4S has a 10-pin male connector for the RZ600 ZigBEE module.

Note: 0 Ohm resistors have been implemented in series with the PIO lines that are used elsewhere in the design, thereby enabling their individual disconnection, should a conflict occur in your application.



Figure 4-23. ZigBEE Interface

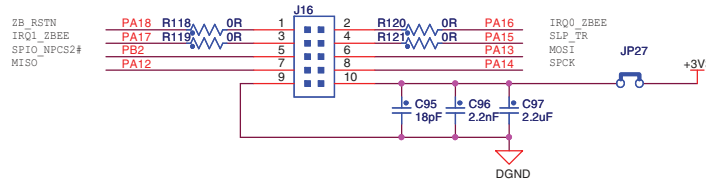

4.3.24 PIO Expansion

The SAM4S product features three PIO controllers, PIOA, PIOB and PIOC, which are multiplexed with the I/O lines of the embedded peripherals. Each PIO Controller controls up to 32 lines (16 for PIOB). Expansion ports J12, J13 and J14 provide PIO lines access for customer defined usage.

Figure 4-24. PIO Expansion

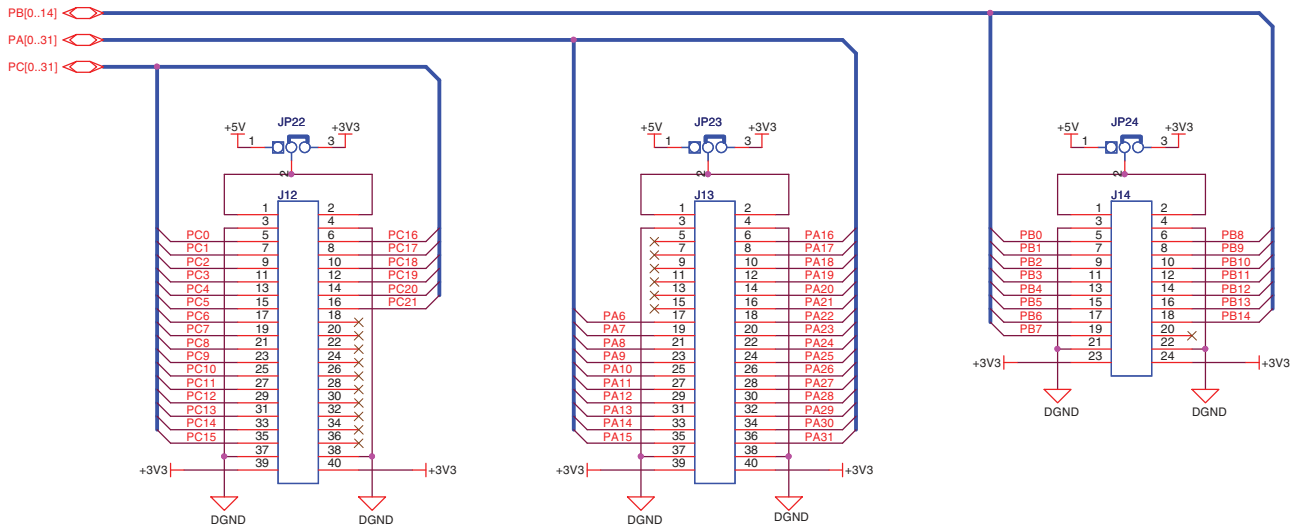

Note: All PIO lines are available on these expansion connectors, except those that are used for the QTouch elements.



4.4 Configuration

This section describes the PIO usage, the jumpers, the test points and the solder drops of a SAM4S-EK board.

4.4.1 PIO Usage

Table 4-1. PIO Port A Pin Assignments and Signal Descriptions

No	I/O Line	Peripheral A	Peripheral B	Peripheral C	Extra Function	System Function	Comment
1	PA0	PWMH0	TIOA0	A17	WKUP0		QTouch slider (left) SNS
2	PA1	PWMH1	TIOB0	A18	WKUP1		QTouch slider (left) SNSK
3	PA2	PWMH2	SCK0	DATRG	WKUP2		QTouch slider (middle) SNS
4	PA3	TWD0	NPCS3				QTouch slider (middle) SNSK
5	PA4	TWCK0	TCLK0		WKUP3		QTouch slider (right) SNS
6	PA5	RXD0	NPCS3		WKUP4		QTouch slider (right) SNSK
7	PA6	TXD0	PCK0				MCI card detection
8	PA7	RTS0	PWMH3			XIN32	CLK32KHz
9	PA8	CTS0	AD12BTRG		WKUP5	XOUT32	CLK32KHz
10	PA9	URXD0	NPCS1	PWMFIO	WKUP6		UART receive data
11	PA10	UTXD0	NPCS2				UART transmit data
12	PA11	NPCS0	PWMH0		WKUP7		NPCS0# (TSC)
13	PA12	MISO	PWMH1				MISO_TSC ZigBEE MISO
14	PA13	MOSI	PWMH2				MOSI_TSC ZigBEE MOSI
15	PA14	SPCK	PWMH3		WKUP8		SPCK_TSC ZigBEE CLK
16	PA15	TF	TIOA1	PWML3	WKUP14 / PIO_DCEN1		ZigBEE SLPTR
17	PA16	TK	TIOB1	PWML2	WKUP15 / PIO_DCEN2		IRQ_TSC ZigBEE IRQ0
18	PA17	TD	PCK1	PWMH3	AD0		BUSY_TSC ZigBEE IRQ1
19	PA18	RD	PCK2	A14	AD1		ZigBEE RSTN
20	PA19	RK	PWML0	A15	AD2/ WKUP9		Blue LED (UserLED1)
21	PA20	RF	PWML1	A16	AD3/ WKUP10		Green LED (UserLED2)
22	PA21	RXD1	PCK1		AD8		USART RXD
23	PA22	TXD1	NPCS3	NCS2	AD9		USART TXD
24	PA23	SCK1	PWMH0	A19	POI_DCCLK		USART transceiver enable
25	PA24	RTS1	PWMH1	A20	POI_DC0		USART RTS
26	PA25	CTS1	PWMH2	A23	POI_DC1		USART CTS
27	PA26	DCD1	TIOA2	MCDA2	POI_DC2		MCI data bit 2
28	PA27	DTR1	TIOB2	MCDA3	POI_DC3		MCI data bit 3
29	PA28	DSR1	TCLK1	MCCDA	POI_DC4		MCI command



Table 4-1. PIO Port A Pin Assignments and Signal Descriptions (Continued)

No	I/O Line	Peripheral A	Peripheral B	Peripheral C	Extra Function	System Function	Comment
30	PA29	RI1	TCLK2	MCKK	POI_DC5		MCI clock
31	PA30	PWML2	NPCS2	MCDA0	WKUP11 / POI_DC6		MCI data bit 0
32	PA31	NPCS1	PCK2	MCDA1	POI_DC7		MCI data bit 1

Table 4-2. PIO Port B Pin Assignments and Signal Descriptions

No	I/O Line	Peripheral A	Peripheral B	Peripheral C	Extra Function	System Function	Comment
1	PB0	PWMH0			AD4		Microphone input
2	PB1	PWMH1			AD5		Analog input
3	PB2	URXD1	NPCS2		AD6 / WKUP12		ZigBee chip select
4	PB3	UTXD1	PCK2		AD7		User push-button 1
5	PB4	TWD1	PWMH2			TDI	JTAG data in
6	PB5	TWCK1	PWML0		WKUP13	TDO/ TRACESWO	JTAG data out
7	PB6					TMS/SWDIO	JTAG test mode select
8	PB7					TCK/SWCLK	JTAG clock
9	PB8					XOUT	CLK12MHz
10	PB9					XIN	CLK12MHz
11	PB10					DDM	USB DM
12	PB11					DDP	USB DP
13	PB12	PWML1				ERASE	Flash erase selector
14	PB13	PWML2	PCK0		DAC0		Audio Output R
15	PB14	NPCS1	PWMH3		DAC1		Audio Output L



Table 4-3. PIO Port C Pin Assignments and Signal Descriptions

No	I/O Line	Peripheral A	Peripheral B	Peripheral C	Extra Function	System Function	Comments
1	PC0	D0	PWML0				EBI D0
2	PC1	D1	PWML1				EBI D1
3	PC2	D2	PWML2				EBI D2
4	PC3	D3	PWML3				EBI D3
5	PC4	D4	NPCS1				EBI D4
6	PC5	D5					EBI D5
7	PC6	D6					EBI D6
8	PC7	D7					EBI D7
9	PC8	NWR0/NWE					TFT LCD write enable
10	PC9	NANDOE					NAND Flash output enable
11	PC10	NANDWE					NAND Flash write enable
12	PC11	NRD					TFT LCD read enable
13	PC12	NCS3			AD12		User push-button 2
14	PC13	NWAIT	PWML0		AD10		LCD backlight control
15	PC14	NCS0					NAND Flash chip select
16	PC15	NCS1	PWML1		AD11		TFT LCD chip select
17	PC16	A21/NANDALE					NAND Flash ALE
18	PC17	A22/NANDCLE					NAND Flash CLE
19	PC18	A0/NBS0	PWMH0			RDYBSY	NAND Flash RDY/BSY
20	PC19	A1	PWMH1				TFT LCD RegSel
21	PC20	A2	PWMH2				Red LED (Power)
22	PC21	A3	PWMH3				USB Vbus detection
23	PC22	A4	PWML3				QTouch valid button SNS
24	PC23	A5	TIOA3				QTouch valid button SNSK
25	PC24	A6	TIOB3				QTouch up button SNS
26	PC25	A7	TCLK3				QTouch up button SNSK
27	PC26	A8	TIOA4				QTouch down button SNS
28	PC27	A9	TIOB4				QTouch down button SNSK
29	PC28	A10	TCLK4		AD13		QTouch left button SNS
30	PC29	A11	TIOA5		AD14		QTouch left button SNSK
31	PC30	A12	TIOB5				QTouch right button SNS
32	PC31	A13	TCLK5				QTouch right button SNSK



4.4.2 Jumpers

The SAM4S-EK board jumpers are essentially used for two main purposes: functional selection or current measurement. Details are given below.

Table 4-4. Jumpers Setting

Designation	Label	Default Setting	Feature
JP1	JTAG	OPEN	Close to select the JTAG boundary scan of the SAM4S
JP2	ADVREF	1-2	Analog reference voltage selection between 3.3V (close 1-2) and 2.5V (close 2-3)
JP3	ERASE	OPEN	Close to reinitialize the Flash contents and some of its NVM bits.
JP4	TEST	Not populated (OPEN)	Close for manufacturing test or fast programming mode
JP5	VDDPLL	CLOSE	Access for current measurement on VDDPLL
JP6	VDDIO	CLOSE	Access for current measurement on VDDIO
JP7	VDDIN	CLOSE	Access for current measurement on VDDIN
JP8	VDDCORE	CLOSE	Access for current measurement on VDDCORE
JP9	CE FLASH	CLOSE	NCS0 enable NAND Flash chip select
JP10	RS485	OPEN	Maintain differential impedance for RS485 interface
JP11	RS485	CLOSE	Maintain impedance matching for RS485 interface
JP12	RS485	OPEN	Maintain differential impedance for RS485 interface
JP13	CS	CLOSE	NCS1 chip select LCD
JP14 - JP15	MIC GAIN0	CLOSE (both) 20db OPEN (both) 26db	Close both to lower gain stage on microphone input.
JP16	ADC input	OPEN	Close for impedance matching on ADC BNC port
JP17 – JP19	MIC Gain stage		Close to mux RIN/LIN into MONO-IN path within audio PA
JP18	SELECT ADC INP	1-2 2-3	ADC input potentiometer ADC input BNC
JP20	MONO/STEREO	CLOSE	Close to fix in mono speaker, no matter the stereo plug state
JP21	DAC output	OPEN	Close for impedance matching on DAC BNC port
JP22	PIO expansion J12 voltage supply	2-3	Set to 3.3V (position 1-2 sets to 5V)
JP23	PIO expansion J13 voltage supply	2-3	Set to 3.3V (position 1-2 sets to 5V)
JP24	PIO expansion J14 voltage supply	2-3	Set to 3.3V (position 1-2 sets to 5V)
JP25	BP2	CLOSE	Open to disconnect and free PB3 for custom usage
JP26	BP3	CLOSE	Open to disconnect and free PC12 for custom usage
JP27	ZIGBEE	CLOSE	Power supply connection/disconnection for the ZigBEE module May also be used as a current measurement point



Table 4-5. Audio Input Configuration

JP17	JP19	MONO-STEREO INPUT
OFF	OFF	PIN test point (TP12)
OFF	ON	Left-in only
ON	OFF	Right-in only
ON	ON	Sum of Left-in and Right-in

4.4.3 Test Points

Some test points have been placed on the SAM4S-EK board for the verification of important signals.

Table 4-6. Test Points

Designation	Part	Description
TP1	Ring Hook	GND
TP2	Ring Hook	GND
TP3	Ring Hook	GND
TP4	Ring Hook	GND
TP5	Pad	UART TXD
TP6	Pad	UART RXD
TP7	Pad	LCD Backlight driver anode
TP8	Pad	Aux ADC input for Touch Screen controller
TP9	Pad	Aux ADC input for Touch Screen controller
TP10	Ring Hook	+5V
TP11	Ring Hook	+3V3
TP12	Pad	Optional Audio PA input

4.4.4 Solder Drops

There are two solder drops designed on the SAM4S-EK for isolation.

Table 4-7. Solder Drops

Designation	Default Setting	Feature
SD1	OPEN	Isolation of DAC output from shared channel (PB14)
SD2	CLOSE	Connects PB14 to the AUDIO_OUTL channel

4.4.5 Assigned PIO Lines, Disconnection Possibility

As pointed out in some previous interface description, 0 Ohm resistors have been inserted on the path of the receiver PIO lines of the SAM4S-EK. These are the PIO lines connected to an external driver on the board. The 0 Ohm resistors allow disconnecting each of these for custom usage (through PIO expansion connectors for example). This feature gives the user an added level of versatility for prototyping a system of his own. See the table below.



Table 4-8. Disconnecting Possibility

Designation	Default Assignment	PIO
R19	0R	PC18, RDY/BSY on NAND Flash
R20	0R	PA29
R22	DNP	Optional write protection on NAND Flash
R25	0R	PA21
R26	0R	PA25
R27	0R	PA24
R28	0R	PA22
R31	0R	PA23
R33	0R	PA22
R34	0R	PA21
R35	0R	PA24
R36	0R	PA25
R44	0R	NRST
R47	0R	PA9
R48	0R	R2OUT/MN5
R59	0R	LCD backlight LED anode
R66	0R	PA11
R67	0R	PA5
R68	0R	PC13
R69	0R	PA4
R70	0R	Vref TSC
R118	0R	PA3 ZB_RSTN
R119	0R	PA5 IRQ1_ZBEE
R120	0R	PA4 IRQ0_ZBEE
R121	0R	PA6 SLP_TR

Table 4-9. Default Not Populated Parts

Reference	Function
J1, R1	External clock resource input
Y1, R3, R7	Backup 12 MHz crystal
R6, R8	Isolation on 12 MHz clock source and GPIO expansion
R9, R10	Isolation on 32 KHz clock source and GPIO expansion
R22	Optional write protection NAND Flash
R23	Optional pull-up for open drain output or equivalent device
R24, R30	Differential impedance matching for RS485 cable



Table 4-9. Default Not Populated Parts

Reference	Function
D1	Optional ESD protection for LCD touch panel
R61, R63, RA2, RA3	Optional data bus termination for LCD controller
JP4	Test mode selection for the SAM chip
J2	Optional QFP socket for the SAM4 chip
K1	Virtual component for QTouch keys set - implemented as copper areas
S1	Virtual component for QTouch slider set - implemented as copper areas
TPxx	Surface-mounted test points (copper area)

4.5 Connectors

4.5.1 Power Supply Connector J9

The SAM4S-EK evaluation board can be powered from a 5VDC power supply connected to the external power supply jack J9. The positive pole is the center pin.

Figure 4-25. Power Supply Connector J9

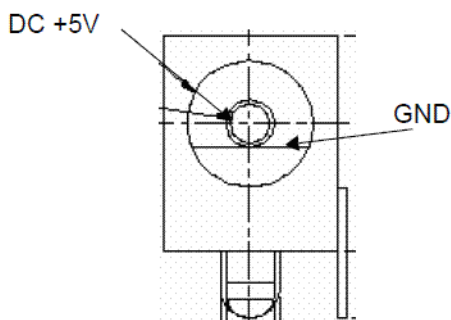

Table 4-10. Power Supply Connector J9 Signal Descriptions

Pin	Mnemonic	Signal Description
1	Center	+5vcc
2	Gnd	Ground reference

4.5.2 USART Connector J5 With RTS/CTS Handshake Support

Figure 4-26. Male RS232/USART Connector J5

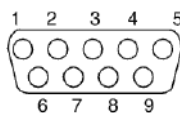

Table 4-11. Serial COM1 Connector J5 Signal Descriptions

Pin	Mnemonic	Signal Description
1, 4, 6, 9	NC	NO CONNECTION
2	TXD TRANSMITTED DATA	RS232 serial data output signal
3	RXD RECEIVED DATA	RS232 serial data input signal
5	GND	GROUND
7	RTS READY TO SEND	Active-positive RS232 input signal
8	CTS CLEAR TO SEND	Active-positive RS232 output signal

4.5.3 UART Connector J7

Male RS232/UART connector J7

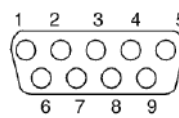

Table 4-12. Male RS232/UART Connector J7 Signal Descriptions

Pin	Mnemonic	Signal Description
1, 4, 6, 7, 8, 9	NC	NO CONNECTION
2	TXD TRANSMITTED DATA	RS232 serial data output signal
3	RXD RECEIVED DATA	RS232 serial data input signal
5	GND	GROUND

4.5.4 USB Device Connector J15

Figure 4-27. Micro-B USB Connector J15

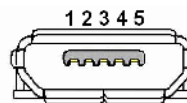

Table 4-13. Micro-B USB Connector J15 Signal Descriptions

Pin	Mnemonic	Signal Description
1	Vbus	5v power
2	DM	Data -
3	DP	Data +
4	Gnd	Ground
5	Shield	Shield



4.5.5 TFT LCD Connector J8

One 39-pin connector is available on the board to connect the LCD module, backlight and touch screen.

Figure 4-28. LCD Connector J8

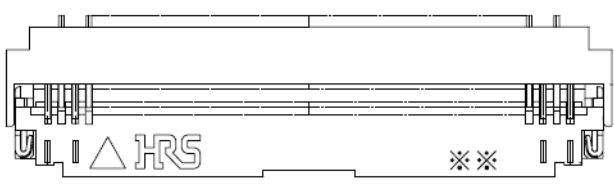

Table 4-14. LCD Connector J8 Signal Descriptions

Pin	Mnemonic	Pin	Mnemonic
1	3V3	2	LCD_DB17 (PC7)
3	LCD_DB16 (PC6)	4	LCD_DB15 (PC5)
5	LCD_DB14 (PC4)	6	LCD_DB13 (PC3)
7	LCD_DB12 (PC2)	8	LCD_DB11 (PC1)
9	LCD_DB10 (PC0)	10	LCD_DB09 (NC)
11	LCD_DB08 (NC)	12	LCD_DB07
13	LCD_DB06 (NC)	14	LCD_DB05 (NC)
15	LCD_DB04 (NC)	16	LCD_DB03 (NC)
17	LCD_DB02 (NC)	18	LCD_DB01 (NC)
19	LCD_DB00 (NC)	20	3V3
21	RD (PC11)	22	WR (PC8)
23	RS (PC19)	24	CS (PC15)
25	RESET	26	IM0
27	IM1	28	GND
29	LED-A	30	LED-K1
31	LED-K2	32	LED-K3
33	LED-K4	34	Y UP
35	Y DOWN	36	X RIGHT
37	X LEFT	38	NC
39	GND		



4.5.6 JTAG Debugging Connector J6

This JTAG connector is a 20-way Insulation Displacement Connector (IDC) keyed box header (2.54 mm male) that mates with IDC sockets mounted on a ribbon cable. Its signal assignment is compatible with the SAM-ICE or any similar third-party interface.

Figure 4-29. JTAG/ICE Connector J6

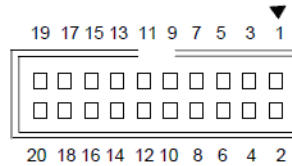

Table 4-15. JTAG/ICE Connector J13 Signal Descriptions

Pin	Mnemonic	Description
1	VTref. 3.3V power	This is the target reference voltage. It is used to check if the target has power, to create the logic-level reference for the input comparators and to control the output logic levels to the target. It is normally fed from Vdd on the target board and must not have a series resistor.
2	Vsupply. 3.3V power	This pin is not connected in SAM-ICE. It is reserved for compatibility with other equipment. Connect to Vdd or leave open in target system.
3	nTRST TARGET RESET — Active-low output signal that resets the target	JTAG Reset. Output from SAM-ICE to the Reset signal on the target JTAG port. Typically connected to nTRST on the target CPU. This pin is normally pulled HIGH on the target to avoid unintentional resets when there is no connection.
4	GND	Common ground
5	TDI TEST DATA INPUT — Serial data output line, sampled on the rising edge of the TCK signal	JTAG data input of target CPU. It is recommended that this pin is pulled to a defined state on the target board. Typically connected to TDI on target CPU.
6	GND	Common ground
7	TMS TEST MODE SELECT –	JTAG mode set input of target CPU. This pin should be pulled up on the target. Typically connected to TMS on target CPU. Output signal that sequences the target's JTAG state machine, sampled on the rising edge of the TCK signal.
8	GND	Common ground
9	TCK TEST CLOCK — Output timing signal, for synchronizing test logic and control register access	JTAG clock signal to target CPU. It is recommended that this pin is pulled to a defined state on the target board. Typically connected to TCK on target CPU.
10	GND	Common ground
11	RTCK Input Return test clock signal from the target	Some targets must synchronize the JTAG inputs to internal clocks. To assist in meeting this requirement, a returned and retimed TCK can be used to dynamically control the TCK rate. SAM-ICE supports adaptive clocking which waits for TCK changes to be echoed correctly before making further changes. Connect to RTCK if available, otherwise to GND.
12	GND	Common ground
13	TDO JTAG TEST DATA OUTPUT — Serial data input from the target	JTAG data output from target CPU. Typically connected to TDO on target CPU.
14	GND	Common ground



Table 4-15. JTAG/ICE Connector J13 Signal Descriptions (Continued)

Pin	Mnemonic	Description
15	nSRST RESET —	Active-low reset signal. Target CPU reset signal
16	GND	Common ground
17	RFU	This pin is not connected in SAM-ICE.
18	GND	Common ground
19	RFU	This pin is not connected in SAM-ICE.
20	GND	Common ground

4.5.7 SD/MMC - MCI Connector J3

Figure 4-30. SD/MMC Connector J3

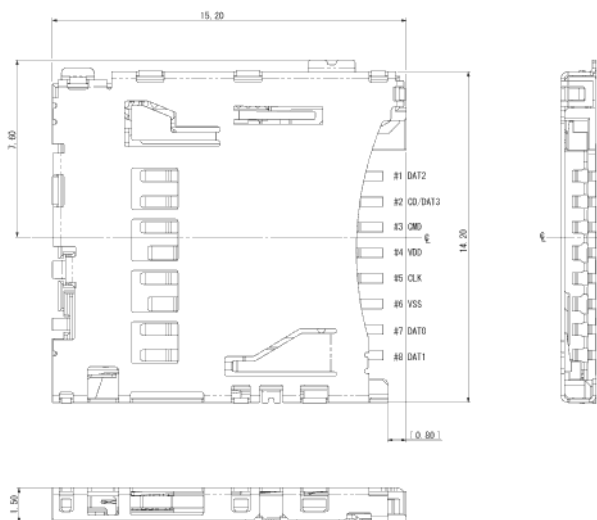

Table 4-16. SD/MMC Connector J3 Signal Descriptions

Pin	Mnemonic	Pin	Mnemonic
1	RSV/DAT3	2	CDA
3	GND	4	VCC
5	CLK	6	GND
7	DAT0	8	DAT1
9	DAT2	10	Card Detect
11	GND	12	



4.5.8 Analog Connector CN1 & CN2

Figure 4-31. Analog Input Connector CN1 and Analog Output CN2, Bottom View

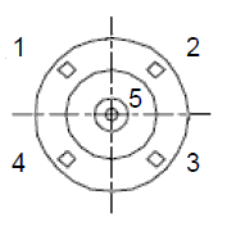

Table 4-17. Analog Input, Output Connector CN1, CN2 Signal Descriptions

Pin	Mnemonic
1, 2, 3, 4	GND
5	Analog input PB1 for CN1 and analog output PB13 for CN2 respectively

4.5.9 RS485 Connector J14

Figure 4-32. RS485 Connector J14

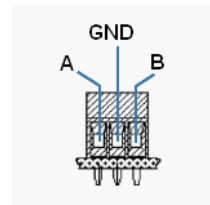

Table 4-18. RS485 J14 Signal Descriptions

Pin	Mnemonic
1	A - non-inverted RS485 signal A
2	Frame ground
3	B - non-inverted RS485 signal B



4.5.10 Headphone Connector J11

Figure 4-33. Headphone J11



Table 4-19. Headphone J11 Signal Descriptions

Pin	Mnemonic
1	AGND
2	Out left
3	
4	
5	Out Right

4.5.11 ZigBEE Connector J16

Figure 4-34. ZigBee Connector J16

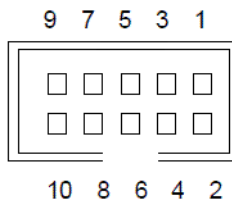

Table 4-20. Connector J16 Signal Descriptions

Function	Signal Name	Port	Pin	Pin	Port	Signal Name	Function	Option on Misc. Port Set by Zero Ohm Resistor or Solder Shunts
Reset	/RST		1	2		Misc.		EEPROM for MAC address, CAP array settings and serial number TST: test mode activation CLKM: RF chip clock output
Interrupt Request	IRQ		3	4		SLP_TR	SLP_TR	
SPI chip select	/SEL		5	6		MOSI	SPI MOSI	
SPI MISO	MISO		7	8		SCLK	SPI CLK	
Power Supply	GND	GND	9	10	VCC	VCC	VCC	Voltage range: 1.8v to 5.5v, typically regulated to 3.3v



4.5.12 PIO Expansion Port C Connector J12

Figure 4-35. PIO Expansion Connector J12

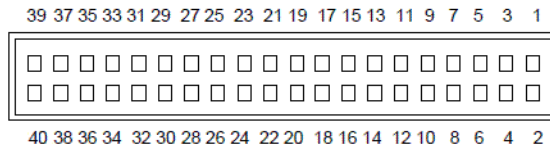

Table 4-21. Connector J12 Signal Descriptions

Pin	Mnemonic	Pin	Mnemonic
1	+5V or +3v3	2	+5V or +3v3
3	GND	4	GND
5	PC0	6	PC16
7	PC1	8	PC17
9	PC2	10	PC18
11	PC3	12	PC19
13	PC4	14	PC20
15	PC5	16	PC21
17	PC6	18	NC
19	PC7	20	NC
21	PC8	22	NC
23	PC9	24	NC
25	PC10	26	NC
27	PC11	28	NC
29	PC12	30	NC
31	PC13	32	NC
33	PC14	34	NC
35	PC15	36	NC
37	GND	38	GND
39	3V3	40	3V3



4.5.13 PIO Expansion Port A Connector J13

Figure 4-36. PIO Expansion Connector J13

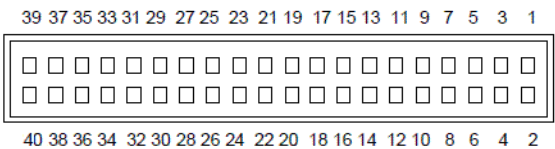

Table 4-22. Connector J13 Signal Descriptions

Pin	Mnemonic	Pin	Mnemonic
1	+5V or +3v3	2	+5V or +3v3
3	GND	4	GND
5	NC	6	PA16
7	NC	8	PA17
9	NC	10	PA18
11	NC	12	PA19
13	NC	14	PA20
15	NC	16	PA21
17	PA6	18	PA22
19	PA7	20	PA23
21	PA8	22	PA24
23	PA9	24	PA25
25	PA10	26	PA26
27	PA11	28	PA27
29	PA12	30	PA28
31	PA13	32	PA29
33	PA14	34	PA30
35	PA15	36	PA31
37	GND	38	GND
39	3V3	40	3V3





Section 5

Schematics

5.1 Schematics

This section contains the following schematics:

- Block diagram
- General information
- Microcontroller
- NAND Flash, serial interface
- TFT LCD & Touch
- Audio & Power Supply
- USB, LEDs, push-buttons & ZigBEE

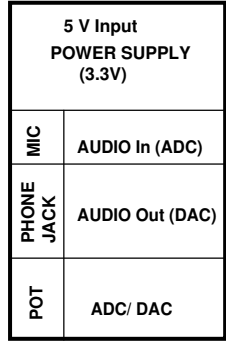

Sheet 6

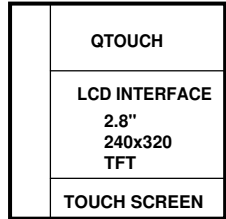

Sheet 5



Sheet 2

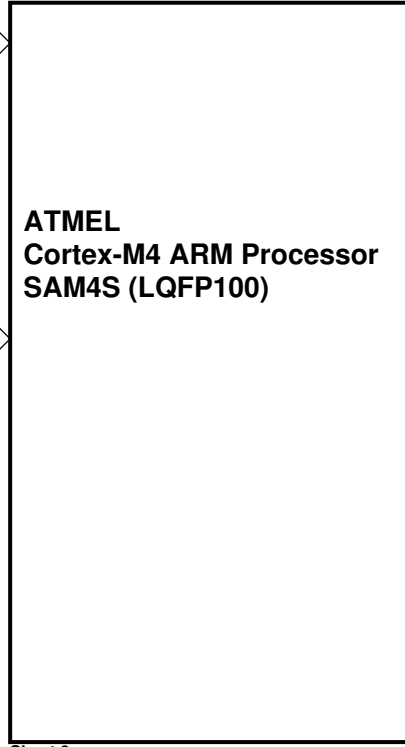

Sheet 3

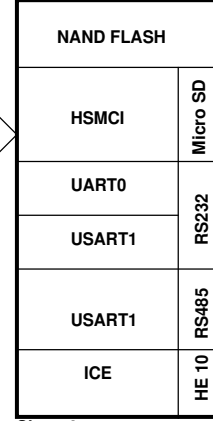

Sheet 4

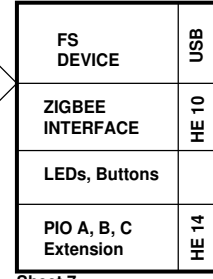

Sheet 7

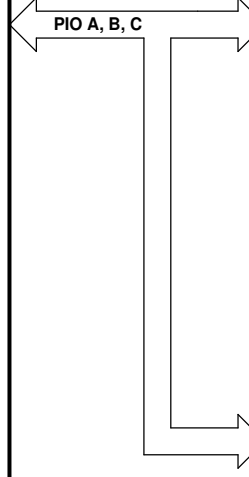
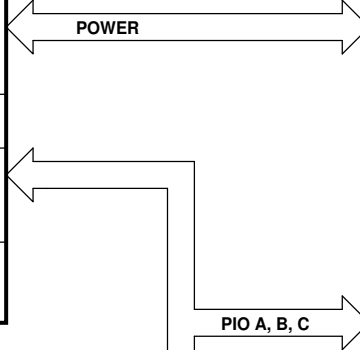

ATMEL ROUSSET®					
REV. A	INIT EDIT	JH	08-Mar-11	XXX	XX-XXX-XX
MODIF.	DES.	DATE	VER.	DATE	
SCALE 1/1				REV. A	SHEET 1/1
Block Diagram					
<small>This agreement is our property. Reproduction and publication without our written authorization shall expose offender to legal proceedings.</small>					

REVISION HISTORY

REV	DATA	NOTE
A	2011.03	ORIGINAL RELEASED

SCHEMATICS CONVENTIONS

(1) Resistance Unit: "K" is "Kohm", "R" is "Ohm?"
(2) "nm" means the component is not populated by default

JUMPER and SOLDERDROP

PAGE	REFERENCE	DEFAULT	FUNCTION
3	JP1	OPEN	Close to select JTAG boundary scan
	JP2	1-2	Analog reference voltage selection between 3.3V and 3.0V
	JP3	OPEN	Close to reinitialize the Flash contents and some of its NVM bits
	JP4	OPEN	Close for manufacturing test or fast programming mode
	JP5, JP6, JP7, JP8	CLOSE	Access for current measurement on each power rail
4	JP9	CLOSE	Nand Flash chip select enable
	JP11	CLOSE	RS485 bus termination enable
	JP10, JP12	OPEN	RS485 pull resistor selectors
	JP31	1-2	RS232 USART and RS485 selection
5	JP13	CLOSE	LCD chip select enable
6	JP14, JP15	OPEN	Sync close to degrade gain stage on microphone input
	JP17, JP19	OPEN	Close to mux RIN/LIN into MONO-IN path within audio PA
	JP16, JP21	OPEN	Close for impedance matching on AD/DA BNC port
	JP18	1-2	ADC input selection between BNC port and potentiometer
	JP20	OPEN	Close to fix in mono speaker mode, no matter stereo plug state
	JP29	1-2	AUDIO Amplifier power select between +5V and VCC33
	JP30	1-2	DAC output between AUDIO left channel and BNC connector
7	JP22, JP23, JP24	1-2	DC voltage selection between 3.3V and 5V on PIO expansion ports
	JP25	CLOSE	Button BP2 disable
	JP26	CLOSE	Button BP3 disable
	JP27	CLOSE	Power consumption measure for ZigBEE module

TABLE OF CONTENTS

PAGE	DESCRIPTION
1	Block Diagram
2	Reference guide
3	Microcontroller
4	NAND Flash, RS232, RS485, MCI, JTAG
5	LCD, Touch items
6	Audio, AD/DA, Power
7	IO Expansion, USB, ZigBEE, LED, Button

TEST POINT

PAGE	REFERENCE	FUNCTION
3	TP1, TP2, TP3, TP4	GND
4	TP5	UART TXD
	TP6	UART RXD
5	TP7	LCD backlight driver anode
	TP8, TP9	Aux ADC input for TSC
6	TP12	Optional audio PA input

PIO MUXING

PIOA	USAGE	PIOA	USAGE	PIOB	USAGE	PIOC	USAGE	PIOC	USAGE
PA0	TSLIDR_SL_SNS	PA16	TSC_IRQ/ZB_IRQ0	PB0	MIC INPUT	PC0	D0	PC16	NAND_ALE
PA1	TSLIDR_SL_SNSK	PA17	TSC_BUSY/ZB_IRQ1	PB1	ANA INPUT	PC1	D1	PC17	NAND_CLE
PA2	TSLIDR_SM_SNS	PA18	ZB_RSTN	PB2	ZB_NPCS2	PC2	D2	PC18	NAND_RDYBSY
PA3	TSLIDR_SM_SNSK	PA19	LED_BLUE	PB3	USER_PB1	PC3	D3	PC19	REGSEL_LCD
PA4	TSLIDR_SR_SNS	PA20	LED_GREEN	PB4	JTAG	PC4	D4	PC20	LED_RED(POWER)
PA5	TSLIDR_SR_SNSK	PA21	RXD1	PB5	JTAG	PC5	D5	PC21	USB_CNX
PA6	MCI_CD	PA22	TXD1	PB6	JTAG	PC6	D6	PC22	TVALID_SNS
PA7	CLK_32K	PA23	COM1EN	PB7	JTAG	PC7	D7	PC23	TVALID_SNSK
PA8	CLK_32K	PA24	RTS1	PB8	CLK_12M	PC8	WR_LCD	PC24	TUP_SNS
PA9	RX_UART0	PA25	CTS1	PB9	CLK_12M	PC9	NAND_OE	PC25	TUP_SNSK
PA10	TX_UART0	PA26	MCI	PB10	USB_DDM	PC10	NAND_WE	PC26	TDWN_SNS
PA11	TSC_CS	PA27	MCI	PB11	USB_DDP	PC11	RD_LCD	PC27	TDWN_SNSK
PA12	MISO	PA28	MCI	PB12	ERASE	PC12	USER_PB2	PC28	TLEFT_SNS
PA13	MOSI	PA29	MCI	PB13	AUDIO OUT R	PC13	EN_LCD	PC29	TLEFT_SNSK
PA14	SPCK	PA30	MCI	PB14	AUDIO OUT L	PC14	NAND_NCS0	PC30	TRIGHT_SNS
PA15	ZB_SLPTR	PA31	MCI			PC15	NSC1_LCD	PC31	TRIGHT_SNSK

DEFAULT NO POPULATE PARTS

PAGE	REFERENCE	FUNCTION
3	J1, R1	External clock resource input
	Y1, R3, R7 R6, R8 R9, R10	Backup 12MHz crystal Isolation between 12MHz clock source and GPIO line Isolation between 32KHz clock source and GPIO line
4	R22	Optional write protection on NAND flash
	R24, R30 R25	Differential impedance matching for RS485 cable Disconnect RS485 Receive data from PA21
5	D1	Optional ESD protection for LCD touch panel
	R61, R62, RA2, RA3	Optional databus termination for LCD controller

A	INIT EDIT	JH	08-Mar-11	XXX	XX-XXX-XX				
REV	MODIF.	DES.	DATE	VER.	DATE				
SCALE 1/1				REV.	SHEET				
Board Configuration				A	2/7				

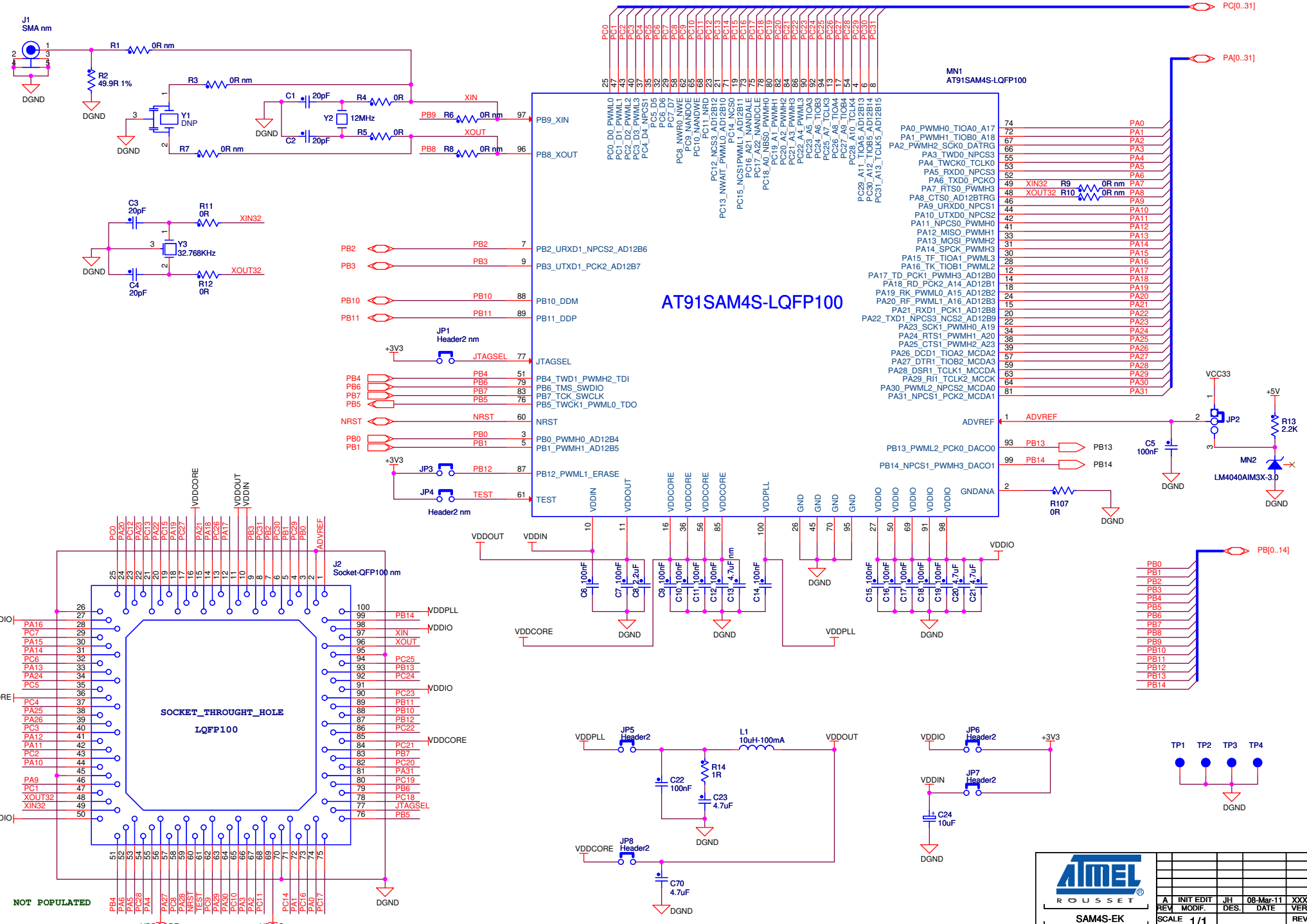

AT91SAM4S-LQFP100

		INIT	EDIT	JH	08-Mar-11	XXX	XX-XXX-XX
		REV	MODIF.	DES.	DATE	VER.	DATE
SAM4S-EK Microcontroller		SCALE	1/1			REV.	3/7
<small>This agreement is our property. Reproduction and publication without our written authorization shall expose offender to legal proceedings.</small>							

NOT POPULATED

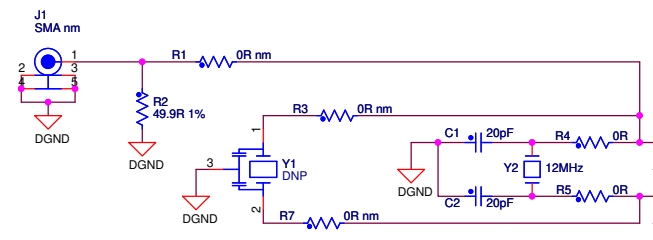
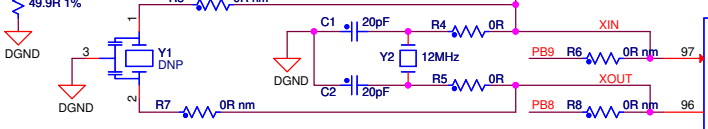
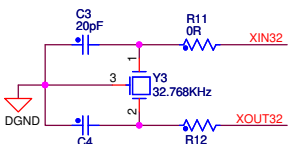
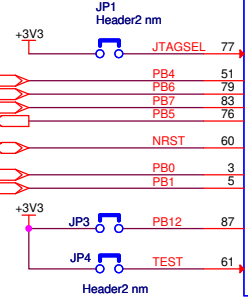
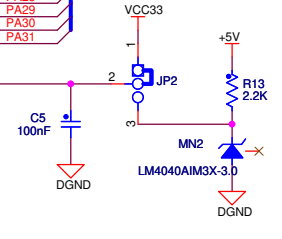
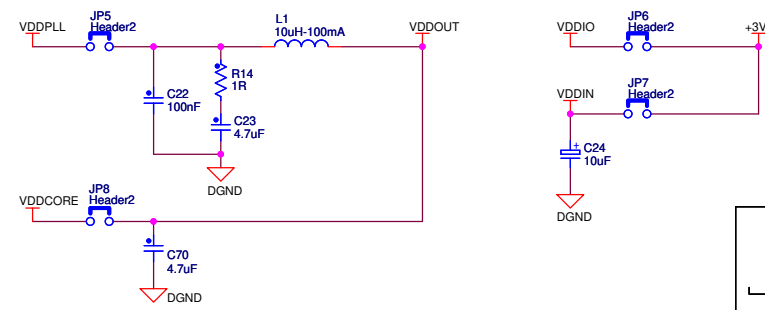
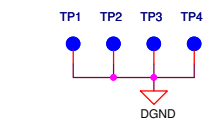

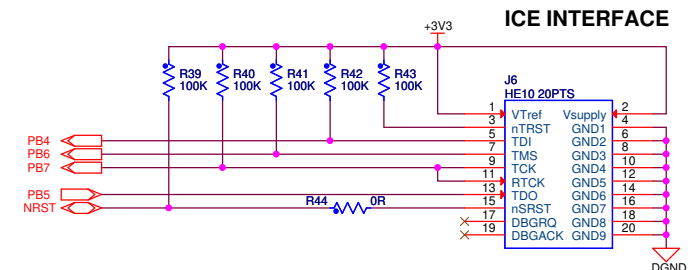
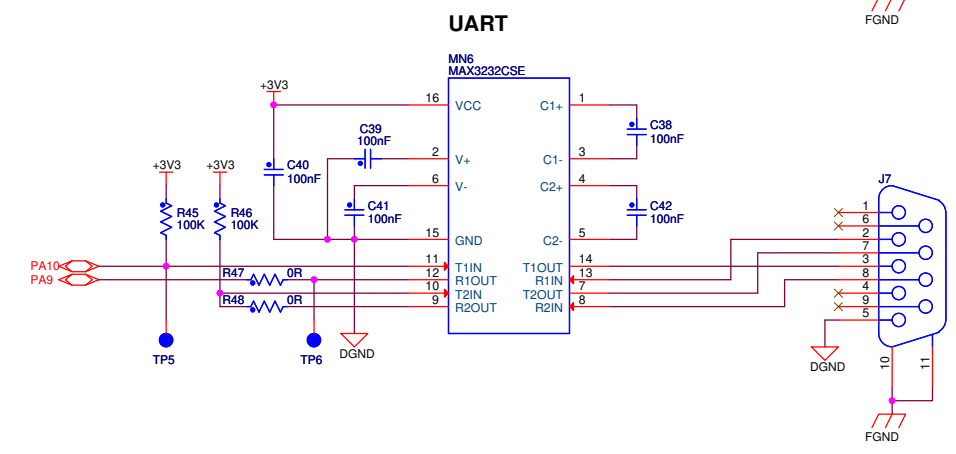
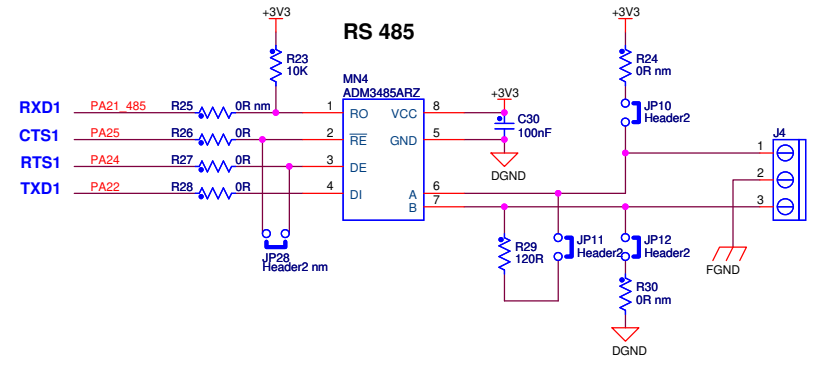
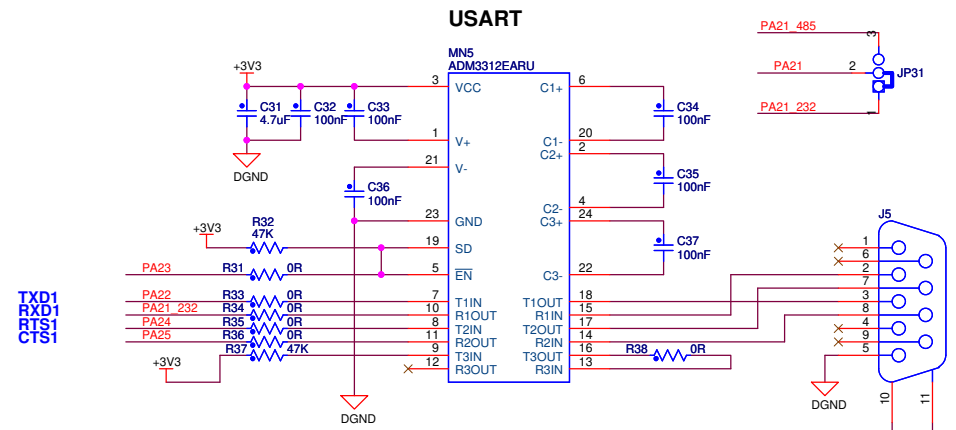
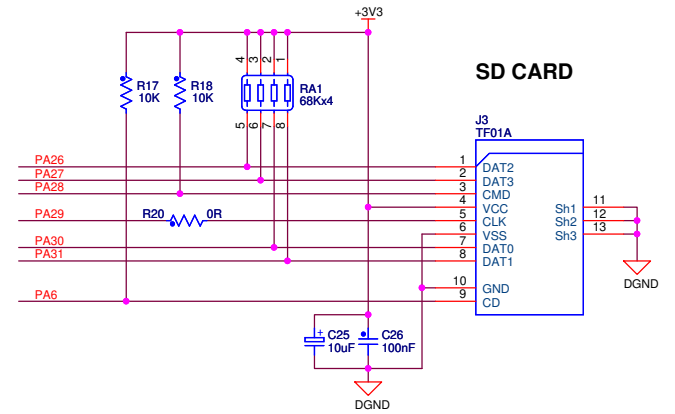
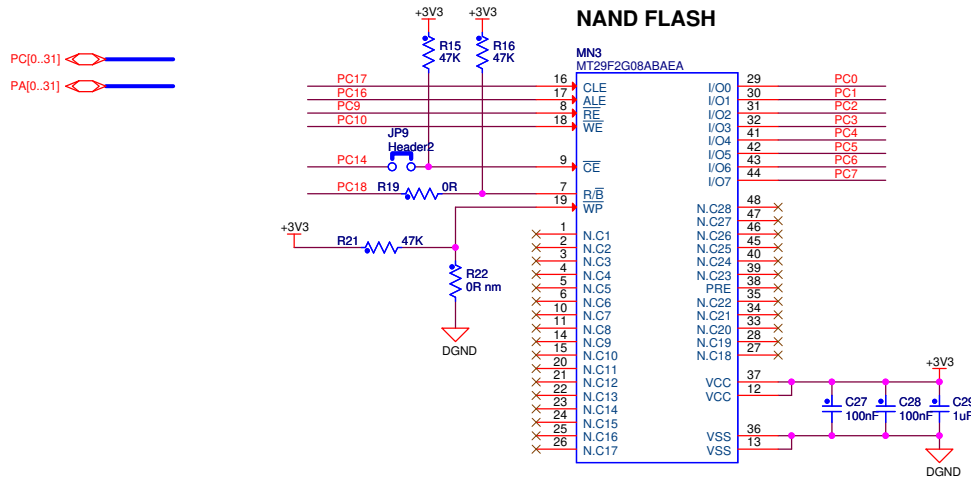

ATMEL ROUSSET					
SAM4S-EK		SCALE 1/1		REV. SHEET A 4/7	
NAND Flash & Serial IF					
REV. A	INIT EDIT	JH	08-Mar-11	XXX	XX-XXX-XX
MODIF.	DES.	DATE		VER.	DATE

This agreement is our property. Reproduction and publication without our written authorization shall expose offender to legal proceedings.

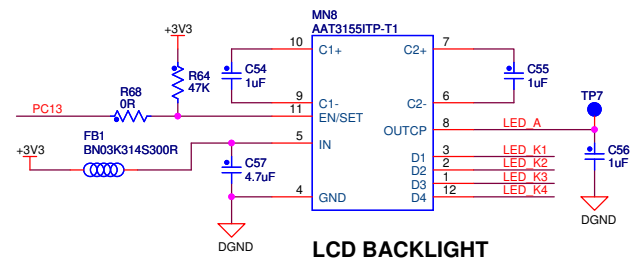
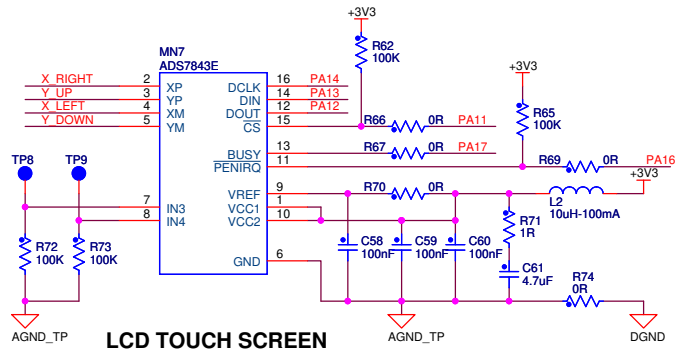
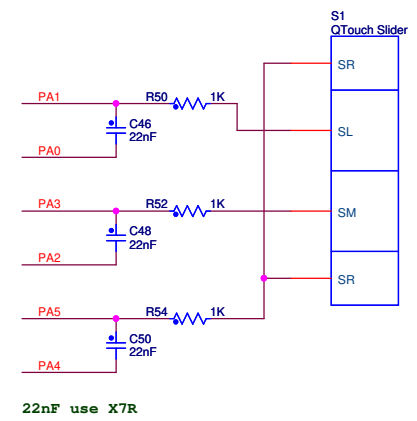
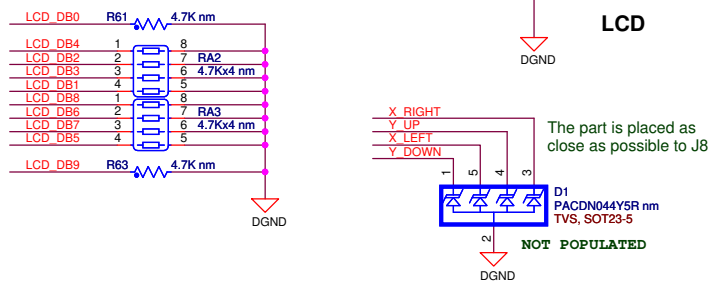
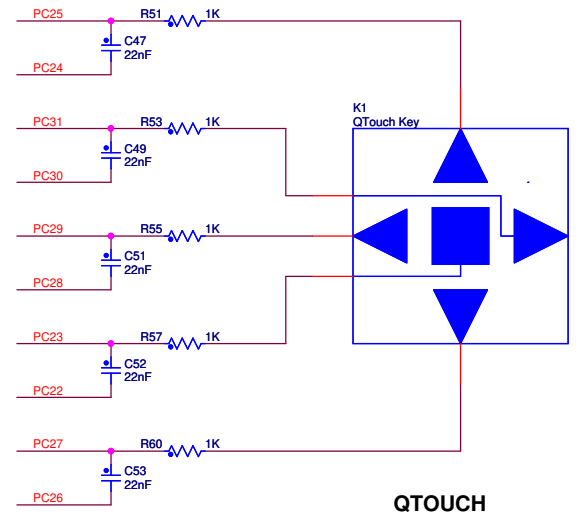
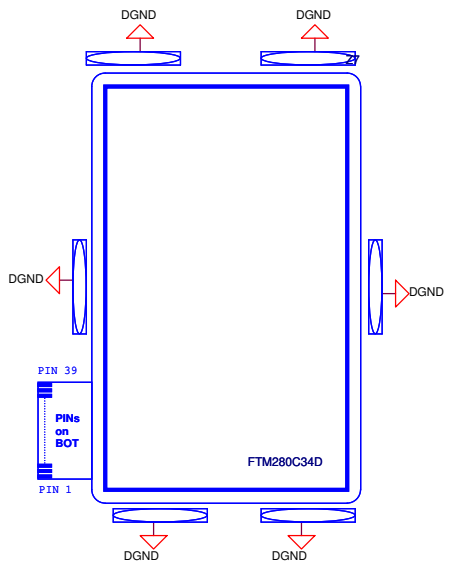
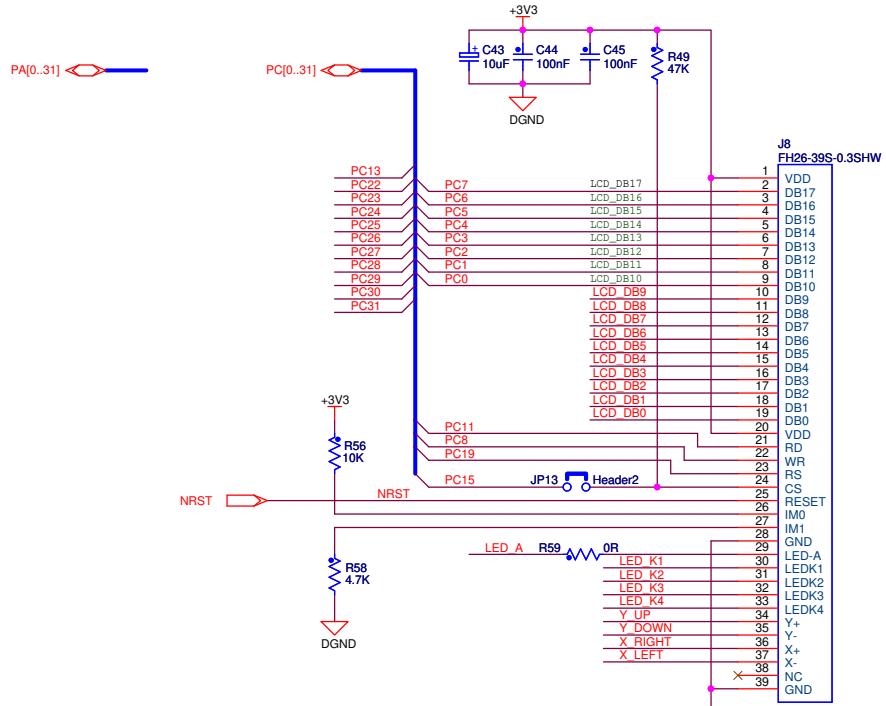

ATMEL							
ROUSSET							
REV	INIT EDIT	JH	DES.	08-Mar-11	XXX	XX-XXX-XX	
SCALE	1/1				REV.	SHEET	
SAM4S-EK						5/	
TFT-LCD & QTouch						A	

AUDIO IN

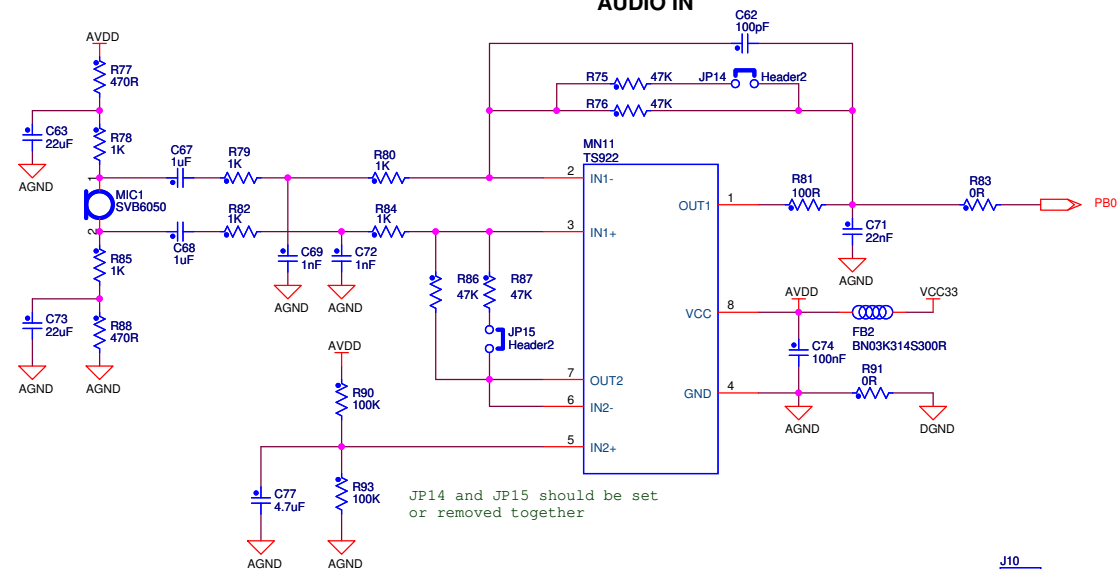

AUDIO OUT

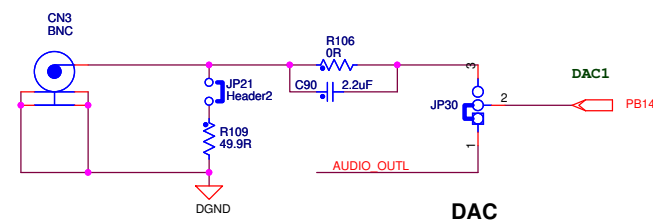
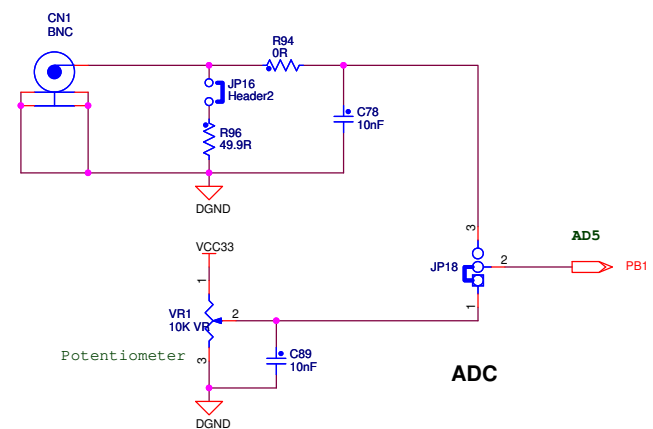
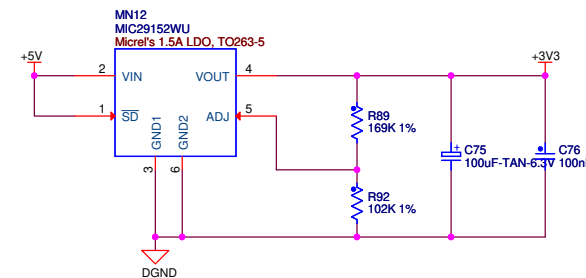
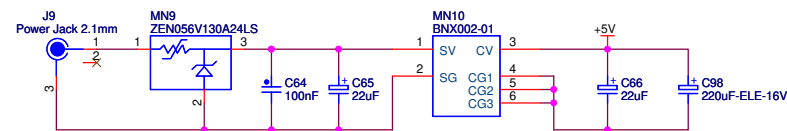
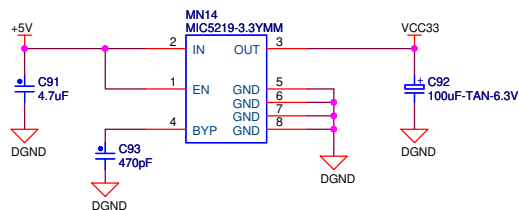
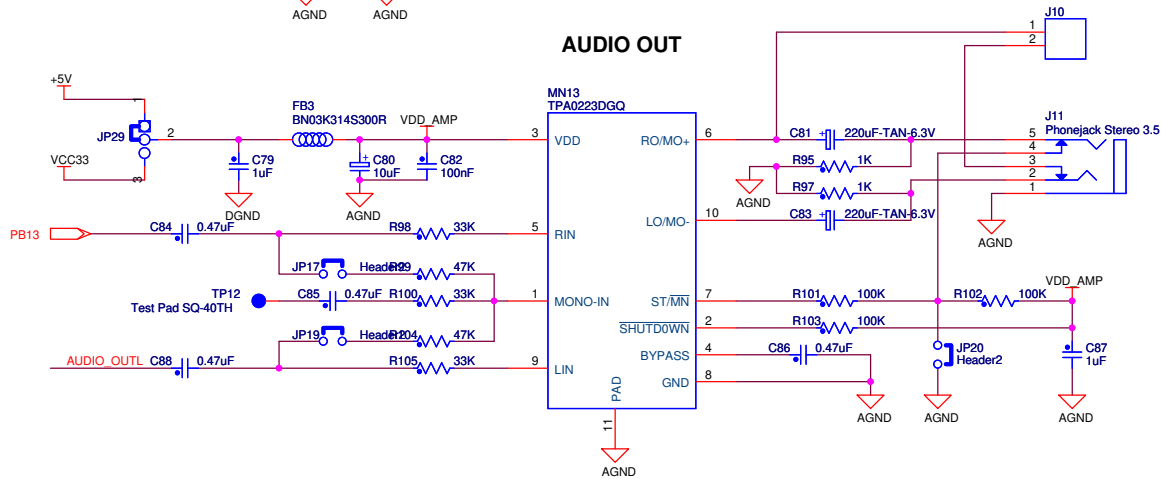

		A		INIT EDIT		JH		08-Mar-11		XXX		XX-XXX-XX	
		REV		MODIF.		DES.		DATE		VER.		DATE	
SAM4S-EK		SCALE		1/1		REV.		A		SHEET		6/7	
Audio & Power supply		SCALE		1/1		REV.		A		SHEET		6/7	

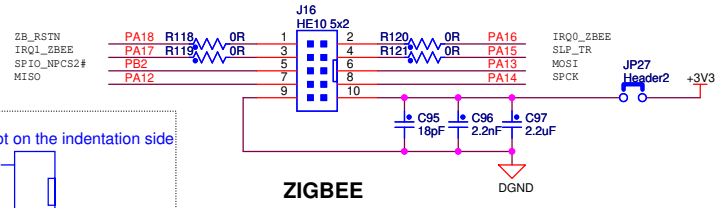
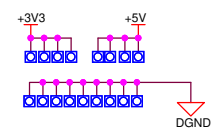
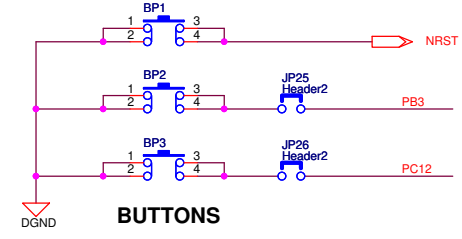
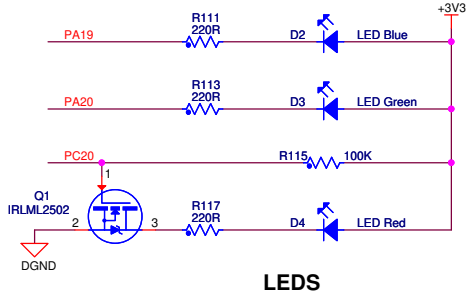
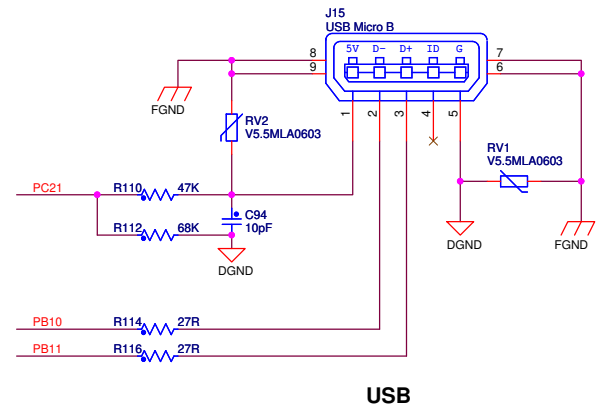
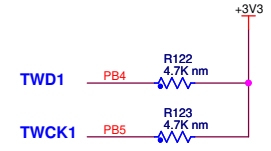
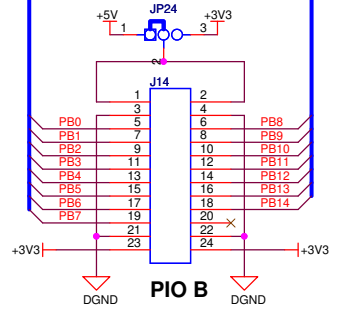
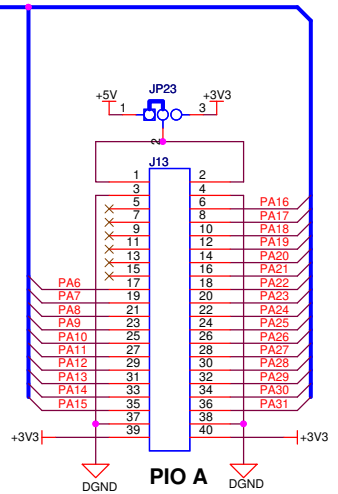
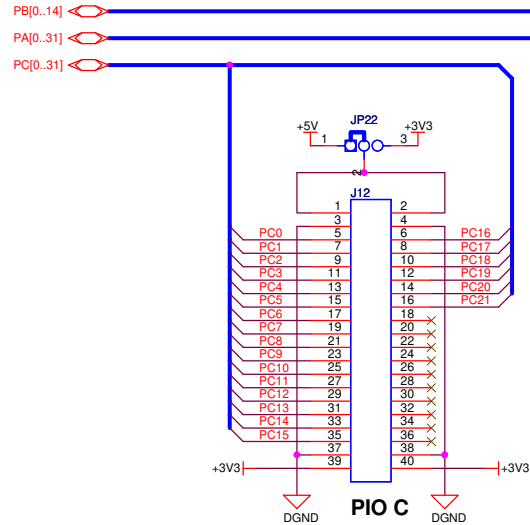

Note:
Pin1 is not on the indentation side

HE10

PROTOTYPE AREA
Pitch = 2.54MM

ATMEL ROUSSET		REV	INIT	EDIT	JH	DES.	08-Mar-11	XXX	XX-XXX-XX
SAM4S-EK		SCALE	1/1					REV.	SHEET
User IF & ZigBee								A	7/7



6.1 Board Recovery

Closing JP3 and powering the board will assert ERASE and clear GPNVM bit 1, and thereby selects the boot from the ROM by default. The MCU will boot from the internal ROM to enable a SAM-BA connection through the UART. Connect the SAM4S-EK UART port (J3) to a PC COM port through an RS232 cross-over cable.

You can then run the SAM-BA application from that PC to program the internal Flash of the MCU as well as the GPNVM bit 1.



Section 7

Revision History

7.1 Revision History

Table 7-1.

Document	Comments	Change Request Ref.
11139A	Initial version.	



Headquarters

Atmel Corporation

2325 Orchard Parkway
San Jose, CA 95131
USA
Tel: (+1) (408) 441-0311
Fax: (+1) (408) 487-2600

International

Atmel Asia Limited

Unit 01-5 & 16, 19F
BEA Tower, Millennium City 5
418 Kwun Tong Road
Kwun Tong, Kowloon
HONG KONG
Tel: (+852) 2245-6100
Fax: (+852) 2722-1369

Atmel Munich GmbH

Business Campus
Parkring 4
D-85748 Garching b. Munich
GERMANY
Tel: (+49) 89-31970-0
Fax: (+49) 89-3194621

Atmel Japan

9F, Tonetsu Shinkawa Bldg.
1-24-8 Shinkawa
Chuo-ku, Tokyo 104-0033
JAPAN
Tel: (81) 3-3523-3551
Fax: (81) 3-3523-7581

Product Contact

Web Site

www.atmel.com
www.atmel.com/AT91SAM

Technical Support

AT91SAM Support
Atmel technical support

Sales Contacts

www.atmel.com/contacts/

Literature Requests

www.atmel.com/literature

Disclaimer: The information in this document is provided in connection with Atmel products. No license, express or implied, by estoppel or otherwise, to any intellectual property right is granted by this document or in connection with the sale of Atmel products. **EXCEPT AS SET FORTH IN ATMEL'S TERMS AND CONDITIONS OF SALE LOCATED ON ATMEL'S WEB SITE, ATMEL ASSUMES NO LIABILITY WHATSOEVER AND DISCLAIMS ANY EXPRESS, IMPLIED OR STATUTORY WARRANTY RELATING TO ITS PRODUCTS INCLUDING, BUT NOT LIMITED TO, THE IMPLIED WARRANTY OF MERCHANTABILITY, FITNESS FOR A PARTICULAR PURPOSE, OR NON-INFRINGEMENT. IN NO EVENT SHALL ATMEL BE LIABLE FOR ANY DIRECT, INDIRECT, CONSEQUENTIAL, PUNITIVE, SPECIAL OR INCIDENTAL DAMAGES (INCLUDING, WITHOUT LIMITATION, DAMAGES FOR LOSS OF PROFITS, BUSINESS INTERRUPTION, OR LOSS OF INFORMATION) ARISING OUT OF THE USE OR INABILITY TO USE THIS DOCUMENT, EVEN IF ATMEL HAS BEEN ADVISED OF THE POSSIBILITY OF SUCH DAMAGES.** Atmel makes no representations or warranties with respect to the accuracy or completeness of the contents of this document and reserves the right to make changes to specifications and product descriptions at any time without notice. Atmel does not make any commitment to update the information contained herein. Unless specifically provided otherwise, Atmel products are not suitable for, and shall not be used in, automotive applications. Atmel's products are not intended, authorized, or warranted for use as components in applications intended to support or sustain life.



© 2011 Atmel Corporation. All rights reserved. Atmel®, logo and combinations thereof DataFlash®, SAM-BA® and others are registered trademarks or trademarks of Atmel Corporation or its subsidiaries. ARM®, Thumb® and the ARMPowered logo® and others are registered trademarks or trademarks ARM Ltd. Windows® and others are registered trademarks or trademarks of Microsoft Corporation in the US and/or other countries. Other terms and product names may be trademarks of others.