

10G Base-T LAN Transformer

ALAN-516

RoHS/RoHS II Compliant



15.37 x 13.84 x 6.35mm

FEATURES:

- Compliant with IEEE802.3 standard
- Compatible with top 10Gig PHY ICs
- ROHS peak reflow temperature rating: 245C
- Low profile package designed for PCI Express
- 1500Vrms Hi-pot

APPLICATIONS:

- 10 Gigabit Ethernet
- Hub, Router, Switch

STANDARD SPECIFICATIONS:

Parameters	Minimum	Typical	Maximum	Units	Notes
Operating Temperature	0		+70	°C	
Storage Temperature	-40		+85	°C	
Turn Ratio (±2%)		1CT: 1CT			Primary: Secondary
Inductance	100			uH	Primary@100KHz/0.1V
Insertion Loss		0.6	1.5	dB	1-500MHz
Return Loss	18			dB	1-40MHz
	17-10log(F/40)				40-500MHz
CM-DMRR	30			dB	1-250MHz
	22				250-500MHz
Crosstalk	40			dB	1-100MHz
	30				100-500MHz
High Pot	1500Vrms				Primary: Secondary
Polarity	Per Schematic				Primary: Secondary

OUTLINE DIMENSIONS:

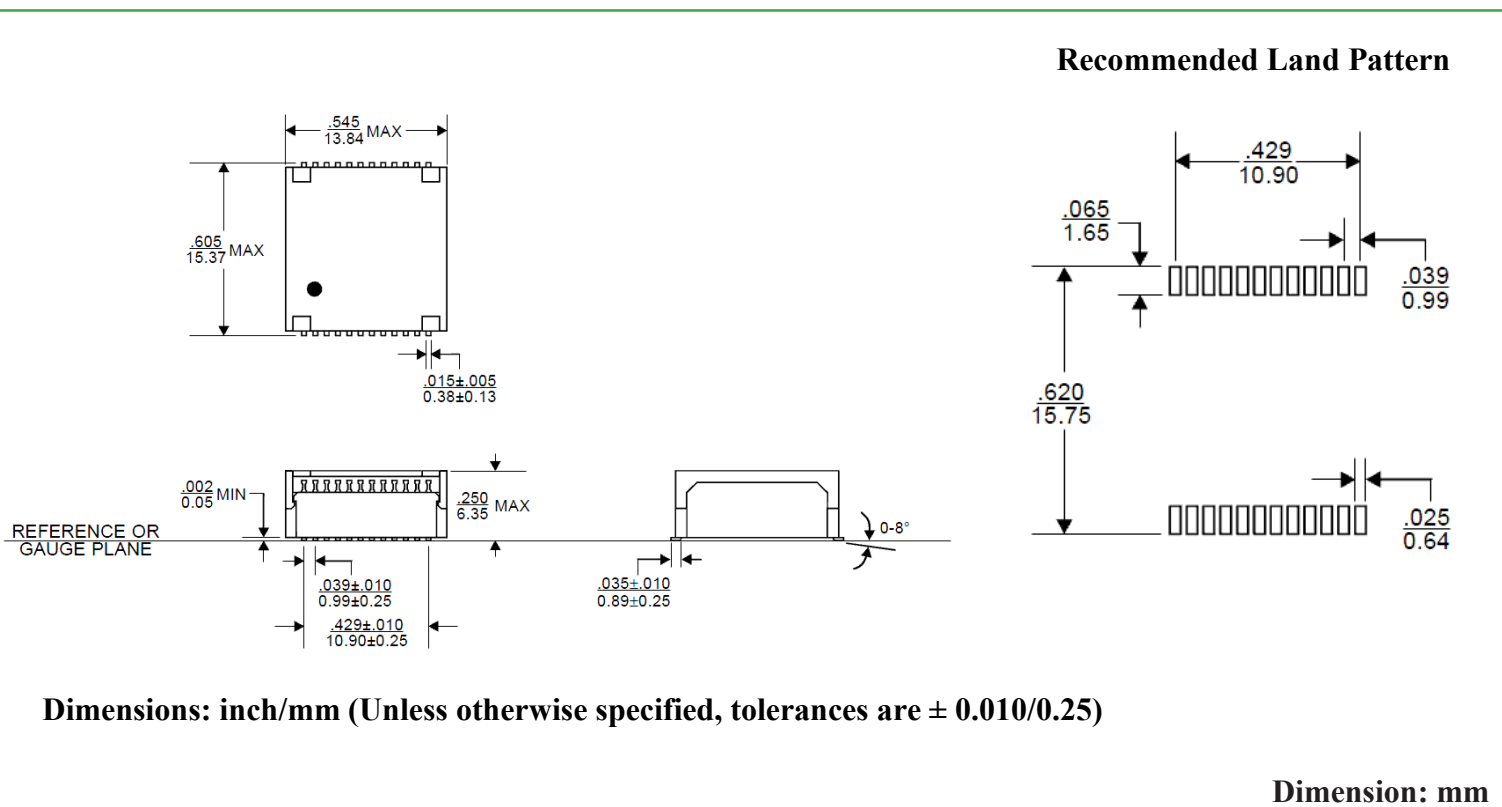

ABRACON IS
ISO 9001:2008
CERTIFIED



Visit www.abracon.com for Terms & Conditions of Sale
30332 Esperanza, Rancho Santa Margarita, California 92688
tel 949-546-8000 | fax 949-546-8001 | www.abracon.com

Revised: 09.08.14

10G Base-T LAN Transformer

ALAN-516

RoHS/RoHS II Compliant



15.37 x 13.84 x 6.35mm

SCHEMATICS:

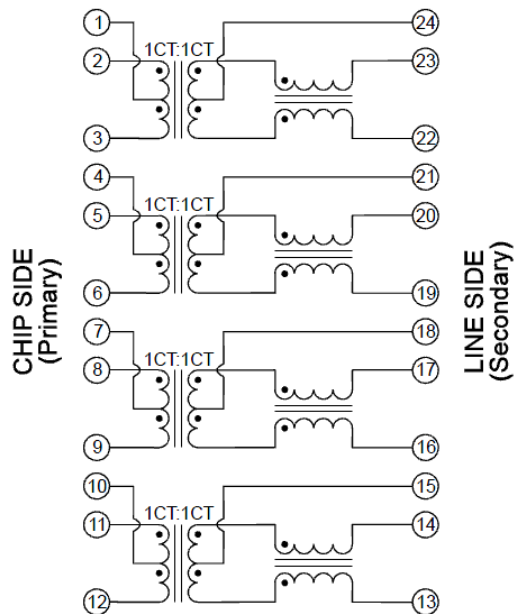

REFLOW PROFILE:

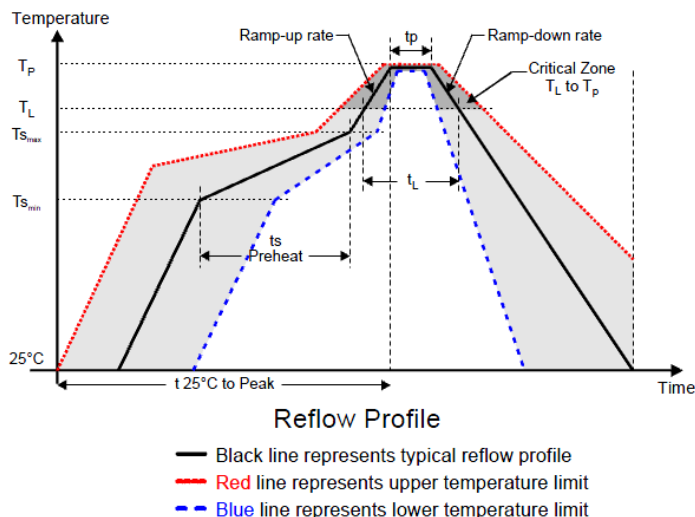

Profile Feature	Pb-Free Assembly
Average Ramp-Up Rate (Ts _{max} to Tp)	3°C /second max.
Preheat	
-Temperature Min (Ts _{min})	150°C
-Temperature Max (Ts _{max})	200°C
-Time (ts _{min} to ts _{max})	60-180 seconds
Time maintained above:	
-Temperature (TL)	217°C
-Time (tL)	60-150 seconds
Peak/Classification Temperature (Tp)	245+0/-5°C
Time within 5°C of actual Peak Temperature (tp)	20-40 seconds
Ramp-Down Rate	6°C /seconds max
Time 25°C to Peak Temperature	8 minutes max.

10G Base-T LAN Transformer

ALAN-516

RoHS/RoHS II Compliant



15.37 x 13.84 x 6.35mm

TAPE & REEL:

Packing 450pcs/ 13" Reel

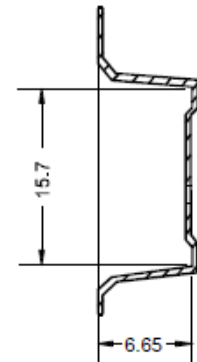
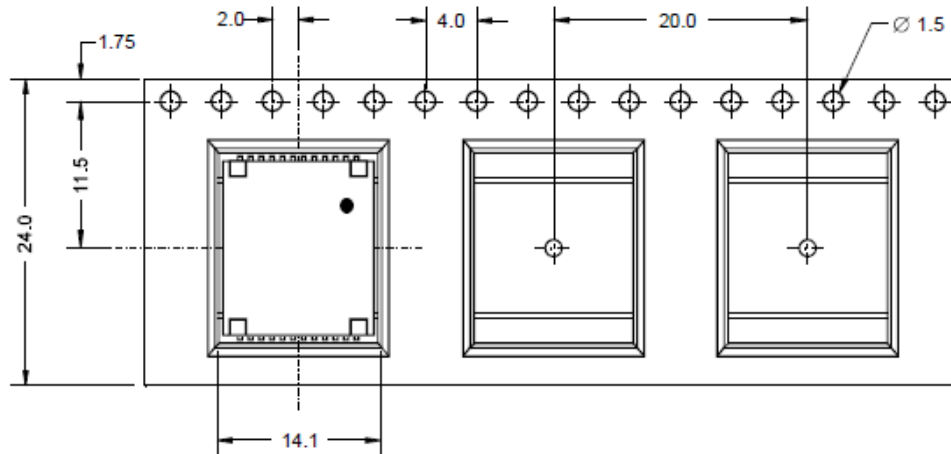

Dimensions: mm

ATTENTION: Abracon Corporation's products are COTS – Commercial-Off-The-Shelf products; suitable for Commercial, Industrial and, where designated, Automotive Applications. Abracon's products are not specifically designed for Military, Aviation, Aerospace, Life-dependant Medical applications or any application requiring high reliability where component failure could result in loss of life and/or property. For applications requiring high reliability and/or presenting an extreme operating environment, written consent and authorization from Abracon Corporation is required. Please contact Abracon Corporation for more information.

ABRACON IS
ISO 9001:2008
CERTIFIED



Visit www.abracon.com for Terms & Conditions of Sale **Revised: 09.08.14**
30332 Esperanza, Rancho Santa Margarita, California 92688
tel 949-546-8000 | fax 949-546-8001 | www.abracon.com