

THIS DRAWING IS UNPUBLISHED. RELEASED FOR PUBLICATION
 © COPYRIGHT BY TYCO ELECTRONICS CORPORATION. ALL INTERNATIONAL RIGHTS RESERVED.

LOC	DIST	REVISIONS					
		P	LTR	DESCRIPTION	DATE	DWN	APVD
CM	52		T1	REVISED PER ECO-09-003230	10FEB09	HMR	KR

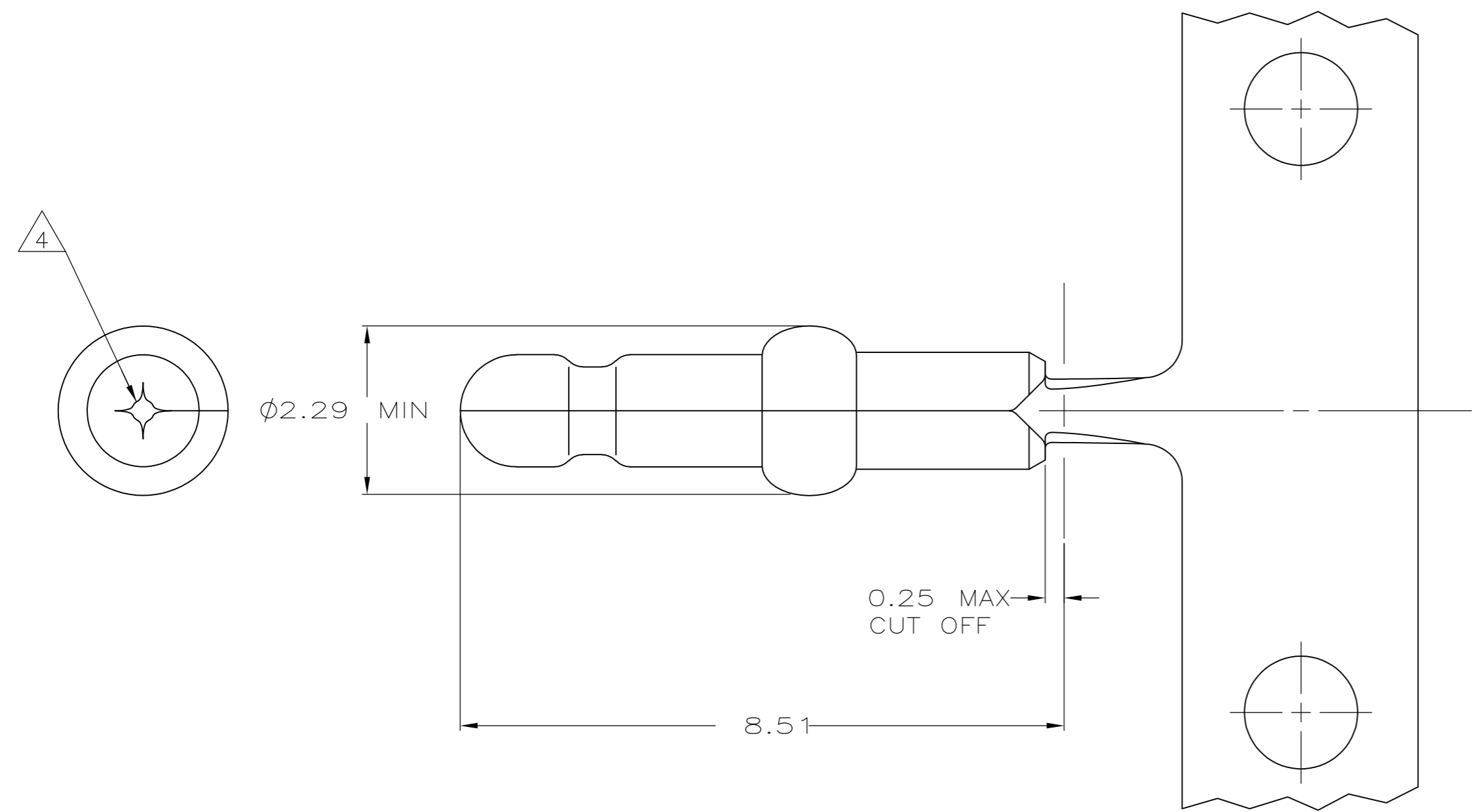

- 1 0.00076 MIN GOLD PLATING IN THIS AREA WITH 0.00381 MIN MATTE TIN LEAD ON THE REMAINDER, BOTH OVER 0.00122 MIN NICKEL UNDERPLATE.
- 2 FITS 1.70 - 1.85 DIAMETER HOLE IN A 1.57 PRINTED CIRCUIT BOARD.
- 3 PARTS TO COMPLY WITH AMP SOLDERABILITY SPECIFICATION 109-11-3.
- 4 0.05 - 0.25 DIAMETER OPENING REQUIRED IN TIP OF PIN.
- 5 APPLICATOR FEED: 8.00 - 8.26
- 6 0.00076 MIN GOLD PLATING IN THIS AREA WITH 0.00381 MIN MATTE TIN ON THE REMAINDER, BOTH OVER 0.00122 MIN NICKEL UNDERPLATE.

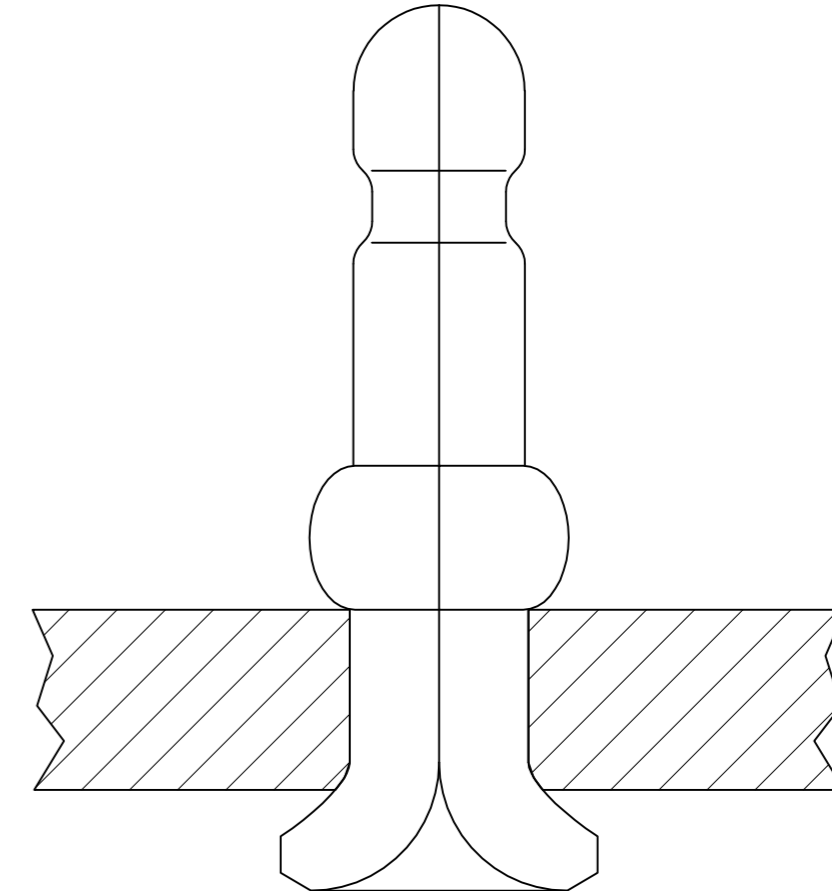
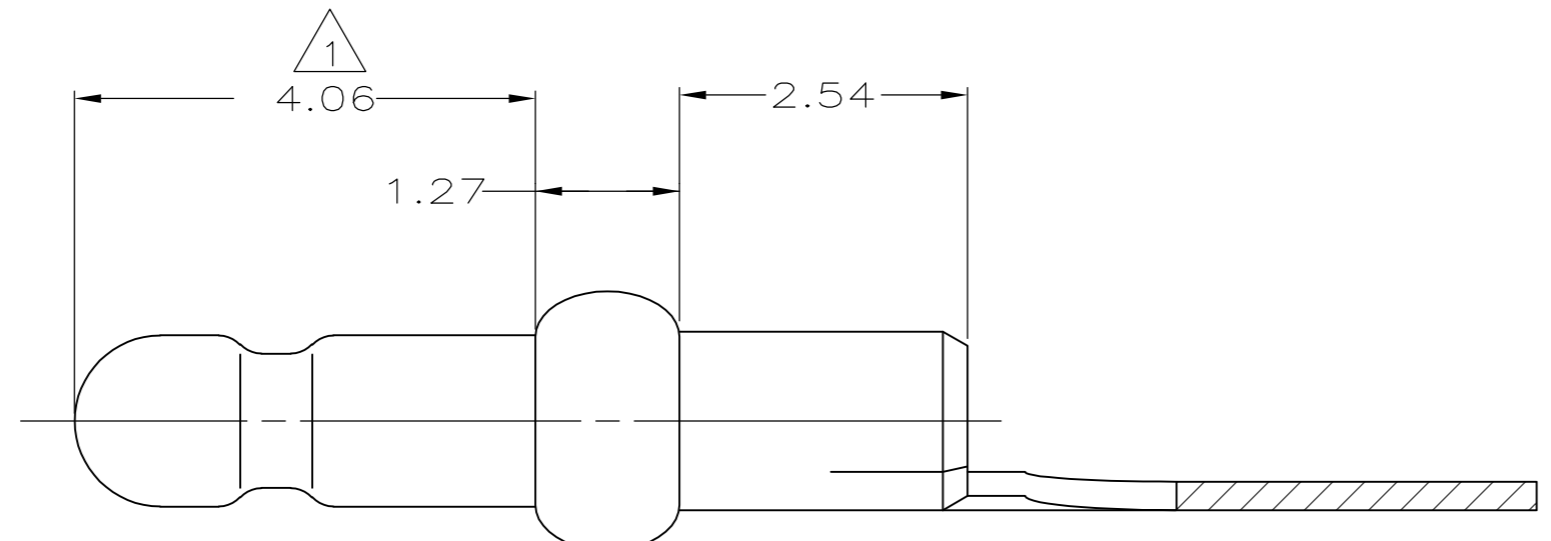

OBSOLETE		3-60824-2
OBSOLETE	PRE TIN	3-60824-1
OBSOLETE		60824-2
	PRE TIN	60824-1
	FINISH	PART NUMBER

0.13	.005	1.70	.067	8.00	.315	-	-
0.05	.002	1.57	.062	4.06	.160	-	-
0.00381	0.000150	1.47	.058	2.54	.100	-	-
0.00127	0.000050	1.27	.050	2.29	.090	8.51	.335
0.00076	0.000030	0.25	.010	1.85	.073	8.26	.325
MM	IN	MM	IN	MM	IN	MM	IN

CONVERSION TABLE

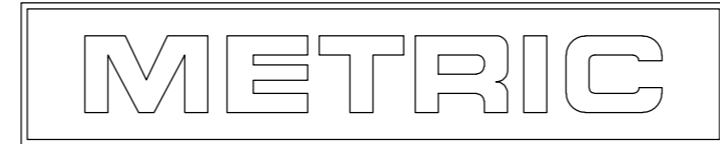

THIS DRAWING IS A CONTROLLED DOCUMENT.		DWN	T. BECK	8-14-97	Tyco Electronics Corporation Harrisburg, PA 17105-3608	
DIMENSIONS: mm		CHK	R. SWING	8-14-97		
TOLERANCES UNLESS OTHERWISE SPECIFIED:		APVD	A. BEDDICK	9-10-97		
0 PLC ± - 1 PLC ± - 2 PLC ± 0.13 3 PLC ± - 4 PLC ± - ANGLES ± -		PRODUCT SPEC	108-1025			
MATERIAL: 0.25 PH BRZ		FINISH	SEE TABLE		APPLICATION SPEC	114-1008
		WEIGHT	-		SIZE	A2
		CUSTOMER DRAWING			CAGE CODE	00779
		SCALE	15:1		DRAWING NO	C=60824
		SHEET	1 of 1		RESTRICTED TO	-
		REV	T1			