

DEVELOPMENT BOARD

HELIKE UA-E3010 | PRODUCT BRIEF

U))) SOUND

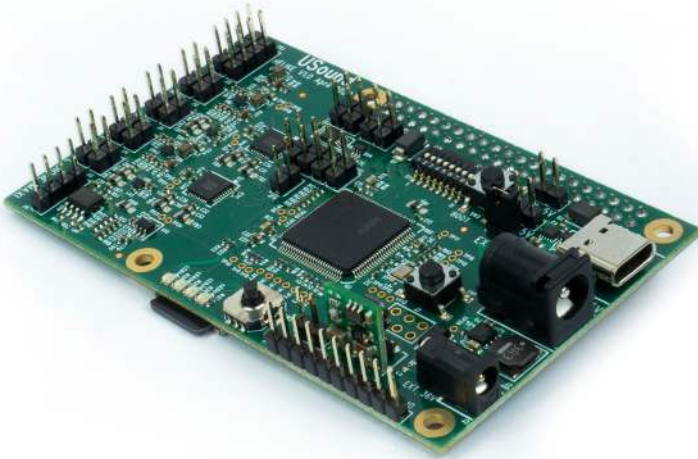

Helike is a development board for assessing multiple USound MEMS speaker-based products and for rapid prototyping. The evaluation board is designed to function in three modes — standalone, as a USB audio device (UAC 2.0) or as an extension board to a Raspberry Pi platform with 40 Pin GPIO interface. Helike also contains a set of amplifiers to drive two MEMS speakers and two electrodynamic speakers along with multiple supply options.

FEATURES

- Standalone mode (SD card playback)
- USB Audio Device (UAC 2.0)
- Extension to Raspberry Pi platform via I2S interface
- Multiple supply options, depending on the availability and application
- Compatible with several USound audio products
- 2 MEMS speaker amplifiers
- 2 electrodynamic speaker amplifiers
- Digital audio equalizer
- Dynamic compression algorithm for MEMS speakers
- SD-Card slot
- Joystick for playback control

CONTENT

INTRODUCTION	3
SYSTEM OVERVIEW	3
MODES OF OPERATION	4
KEY COMPONENTS	4
SOFTWARE	5
SUPPLY OPTIONS	5
MECHANICAL PROPRIETIES	6
PRODUCT COMPATIBILITY	7

REVISION HISTORY

Released in June 2020

INTRODUCTION

Helike is an evaluation board developed to integrate and test USound products. The board functions in a standalone mode, as an extension to Raspberry Pi platform or even as a USB soundcard connected to a mobile device or a PC via USB-C.

In slave mode, the board receives a stereo I2S input signal as an I2S slave (the host MCU drives all the I2S clocks). The I2S signal is provided from the platform at 3.3 V logical levels. A microcontroller on the expansion board receives the I2S signals and performs digital signal processing on them. The audio streams from the μ C/DSP are sent to a pair of digital to analog converters and from there the analog audio streams are routed to the amplifiers.

The μ C/DSP implements a multi-stage equalizer that can be configured via the USB port to adjust the au-

dio streams for the MEMS and electrodynamic speakers according to the used application. Additionally, equalization presets are available for the compatible USound products.

MEMS speaker amplifiers (MEMS AMP), electrodynamic speaker amplifiers (Dynamic AMP) as well as a differential amplifier (Differential AMP) are mounted on the PCB to work with a variety of loads and applications. An output connector section is present to interface to these loads and applications.

This device will be used for evaluating USound audio solutions, rapid prototyping and designing new customer solutions.

SYSTEM OVERVIEW

BLOCK DIAGRAM

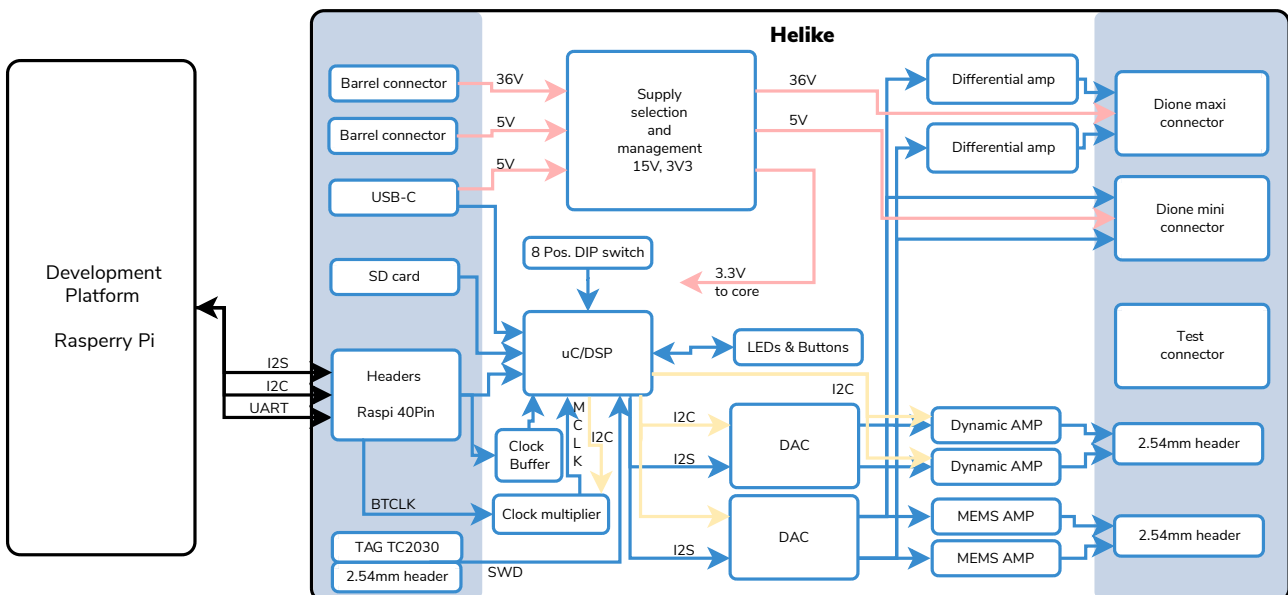

Figure 1: Helike block diagram

MODES OF OPERATION

STANDALONE MODE

In Standalone mode, Helike implements a playback feature in which audio files (mp3 & WAV) are read from a FAT32 formatted SD card and played in an indefinite loop. The audio files are read by the DSP and decoded in case of MP3 and run through a filter chain for MEMS speaker linearization and crossovers. 16 bit per channel & 48 KHz audio sample rate is supported for this mode.

USB AUDIO DEVICE (UAC 2.0) MODE

As a USB audio device (UAC 2.0), Helike implements a USB soundcard feature. The USB audio data is run through a filter chain for MEMS speaker linearization and crossovers. The digital data is then forwarded to the digital to analogue converter and, subsequently, to the amplifiers. Helike can be connected to a PC or a mobile device. 16 bit per channel and 48 kHz audio sample rate are supported in this mode.

SLAVE MODE — EXTENSION TO RASPBERRY PI 4 PLATFORM

The host development board provides data in I2S format. The onboard DSP receives these signals and applies a filter chain for MEMS speaker linearization and crossovers. The digital data is then forwarded to the digital to analogue converter and, subsequently, to the amplifiers. Helike can be connected to a PC or a mobile device. 16 bit per channel and 48 kHz audio sample rate are supported in this mode.

KEY COMPONENTS

- MEMS amplifier is a TI LM48580 with a differential signal amplitude of 30 Vpp.
- Electrodynamic speaker amplifier is TPA2028D1 with a maximum output power of 3 W.
- Differential amp TINE5532 used to convert the balanced DAC output signal to a single-ended variant, and it adapts the signal voltage level in order to drive an (external) Amalthea amplifier to the maximum input voltage of 1.84 Vpp
- μ C/DSP STM32H750 controls the power-up of the devices (enable lines on GPIO's) and configures the DACs and amplifiers via I2C. It implements the audio interface from the host board (I2S slave) to the DAC converter (I2S master). The μ C implements a set of filters that can be configured via the USB port to equalize the MEMS and electrodynamic speakers according to the used application.
- Digital to analogue converter (DAC) Asahi Kasei AK4452VN with 32bit digital filter processing and 115dB of SNR(Signal-to-noise ratio) controlled via I2C by the μ C.

SOFTWARE

The DSP firmware software stack is implemented in C and C++ code, with the low-level BSP, provided by ST Microelectronics (STM32 HAL) and the core DSP functionality is based on ARM CMSIS. Additionally, FreeRTOS is providing real-time scheduling capabilities and manages the system threads. The middleware layer (FATFS & USB UAC) is also provided by ST Microelectronics.

The firmware includes the following standard libraries:

- ARM CMSIS v5
- STMicroelectronics HAL
- FATFS
- USB UAC 2.0

TOOLCHAIN

ARM GCC 9 (2019-q4-major) is used to compile the code. System Workbench is the IDE used to build and debug the firmware (<https://www.openstm32.org/System+Workbench+for+STM32>).

The code can be downloaded and tested from System Workbench via OpenOCD 0.10.0-13 (<https://xpack.github.io/blog/2019/07/17/openocd-v0-10-0-13-released/>) and “GNU MCU C/C++ OpenOCD Debugging v4.4.1” eclipse add-on <https://gnu-mcu-eclipse.github.io/debug/openocd/>

SUPPLY OPTIONS

Depending on the desired application, there are multiple supply options available on the Helike board:

- 36 V barrel connector (Can be replaced by 2.54 mm screw terminal if desired)
- 5 V barrel connector (Can be replaced by 2.54 mm screw terminal if desired)
- USB-C connector with 3A @ 5 V supply

MECHANICAL PROPERTIES

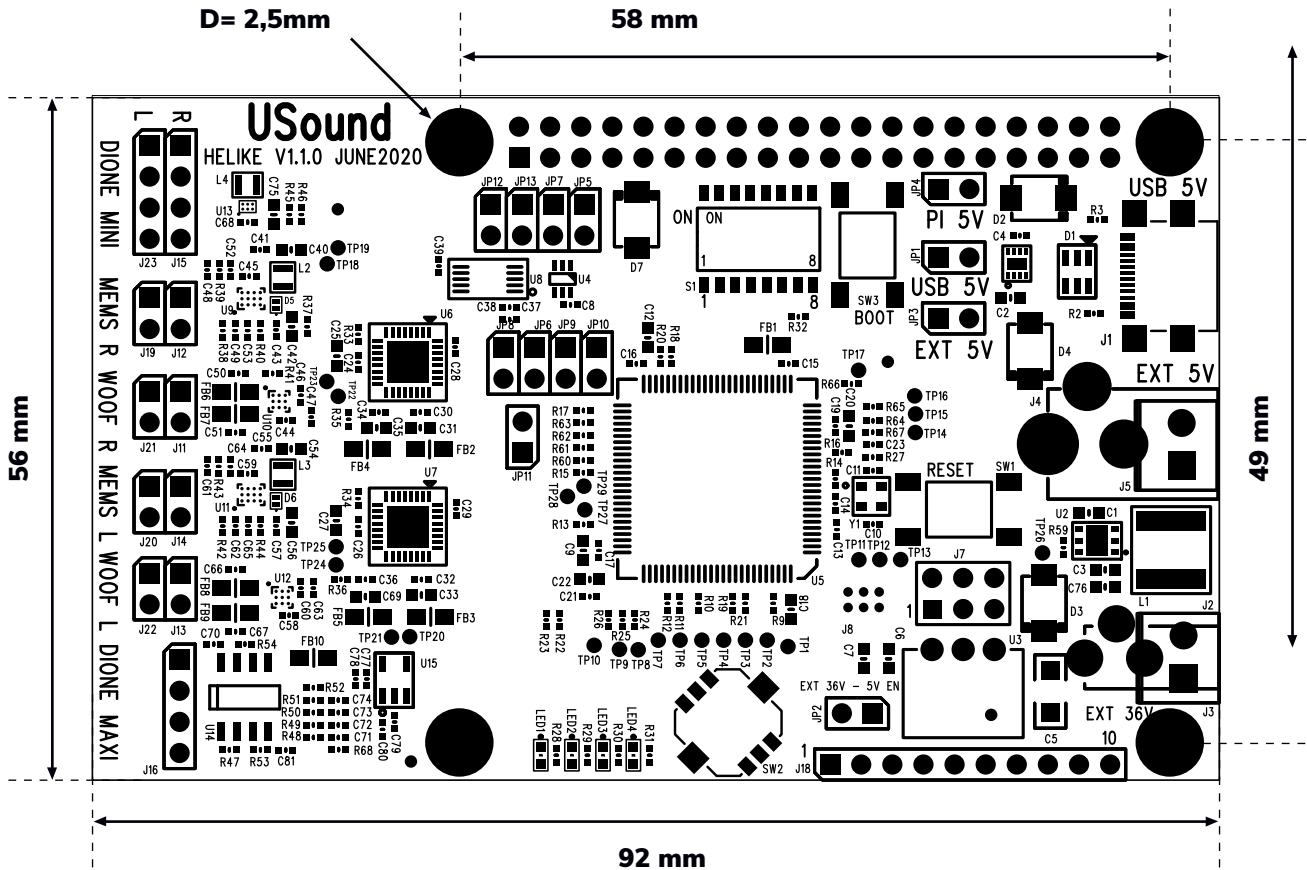

USOUND'S PRODUCTS COMPATIBILITY AND CONNECTION

Usound product	Description	Connector
Dione Maxi	Passive sound stripe includes up to 65 MEMS speakers with external amplifier board	Dione maxi connector
Dione Mini	Sound stripe includes 35 MEMS speakers with integrated amplifiers	Dione mini connector
Carme 3.0	Speaker box for one Ganymede MEMS speaker	2.54 mm header
Sentia 2.0 (coming soon)	In ear earphones using Ganymede MEMS speakers	2.54 mm header
Danube 5.0 (coming soon)	Audio module combining MEMS tweeter and electrodynamic woofer	2.54 mm header
Thera box 1.0 (coming soon)	Speaker box for one Thera hexagonal MEMS speaker	2.54 mm header

IMPORTANT NOTICE AND DISCLAIMER

USound GmbH (“USound”) makes no warranties for the use of USound products, other than those expressly contained in USound’s applicable General Terms of Sale, located at www.usound.com. USound assumes no responsibility for any errors which may have crept into this document, reserves the right to change devices or specifications detailed herein at any time without notice, and does not make any commitment to update the information contained herein. No license to patents or other intellectual property rights of USound are granted in connection with the sale of USound products, neither expressly nor implicitly.

In respect of the intended use of USound products by the customer, the customer is solely responsible for observing existing patents and other intellectual property rights of third parties and for obtaining, as the case may be, the necessary licenses. For more information about USound patents visit <https://www.usound.com/patents/>.

Important note: The use of USound products as components in medical devices and/or medical applications, including but not limited to, safety and life supporting systems, where malfunctions of such USound products might result in damage to and/or injury or death of persons is expressly prohibited, as USound products are neither destined nor qualified for use as components in such medical devices and/or medical applications. The prohibited use of USound products in such medical devices and/or medical applications is exclusively at the risk of the customer.