

712RAHLP

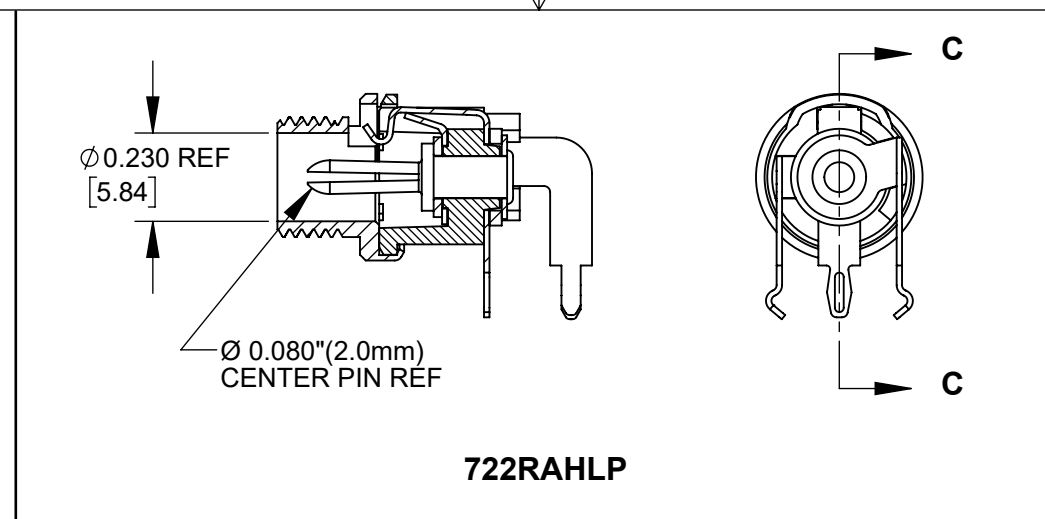

722RAHLP

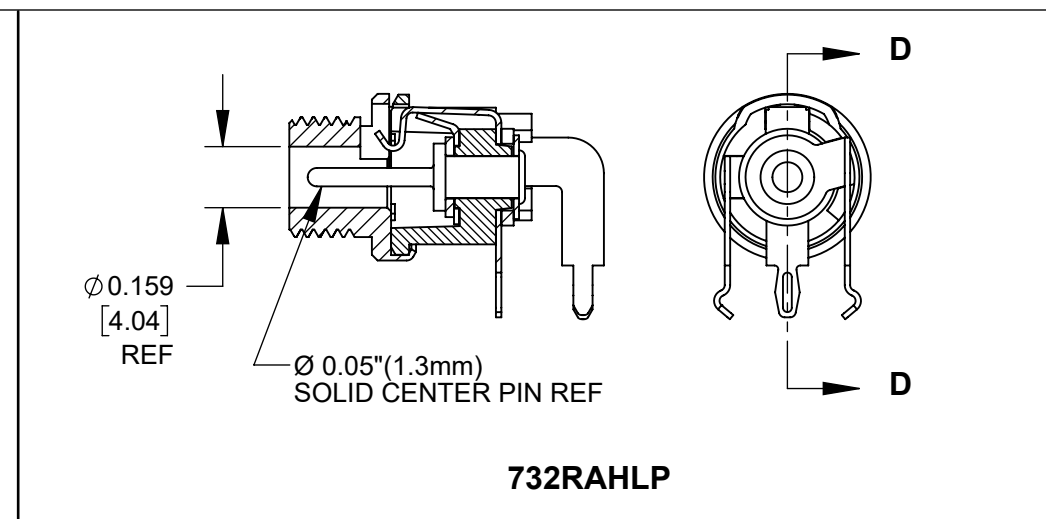

732RAHLP

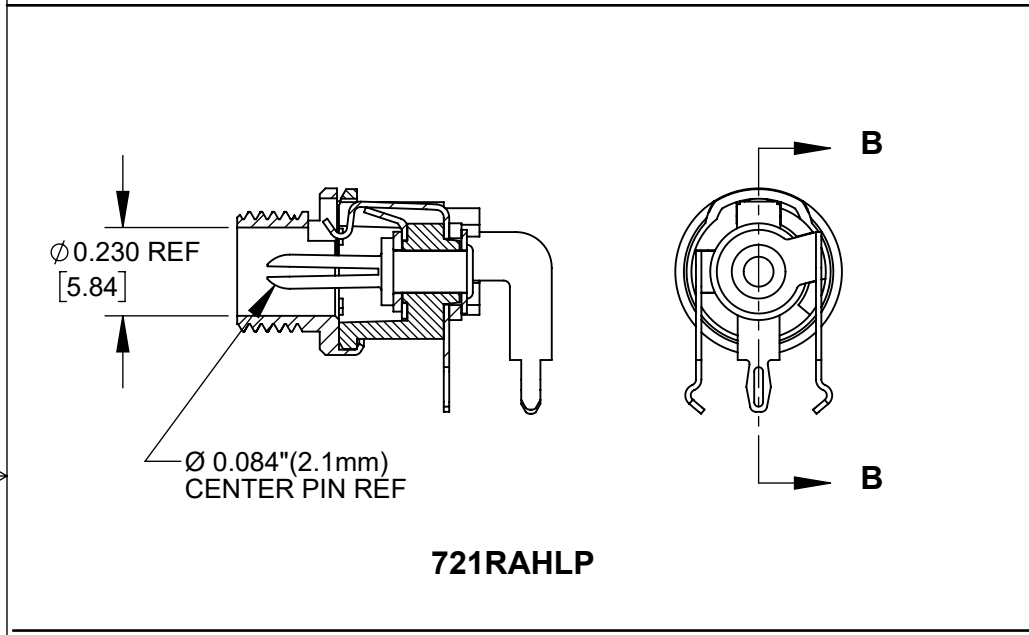

721RAHLP

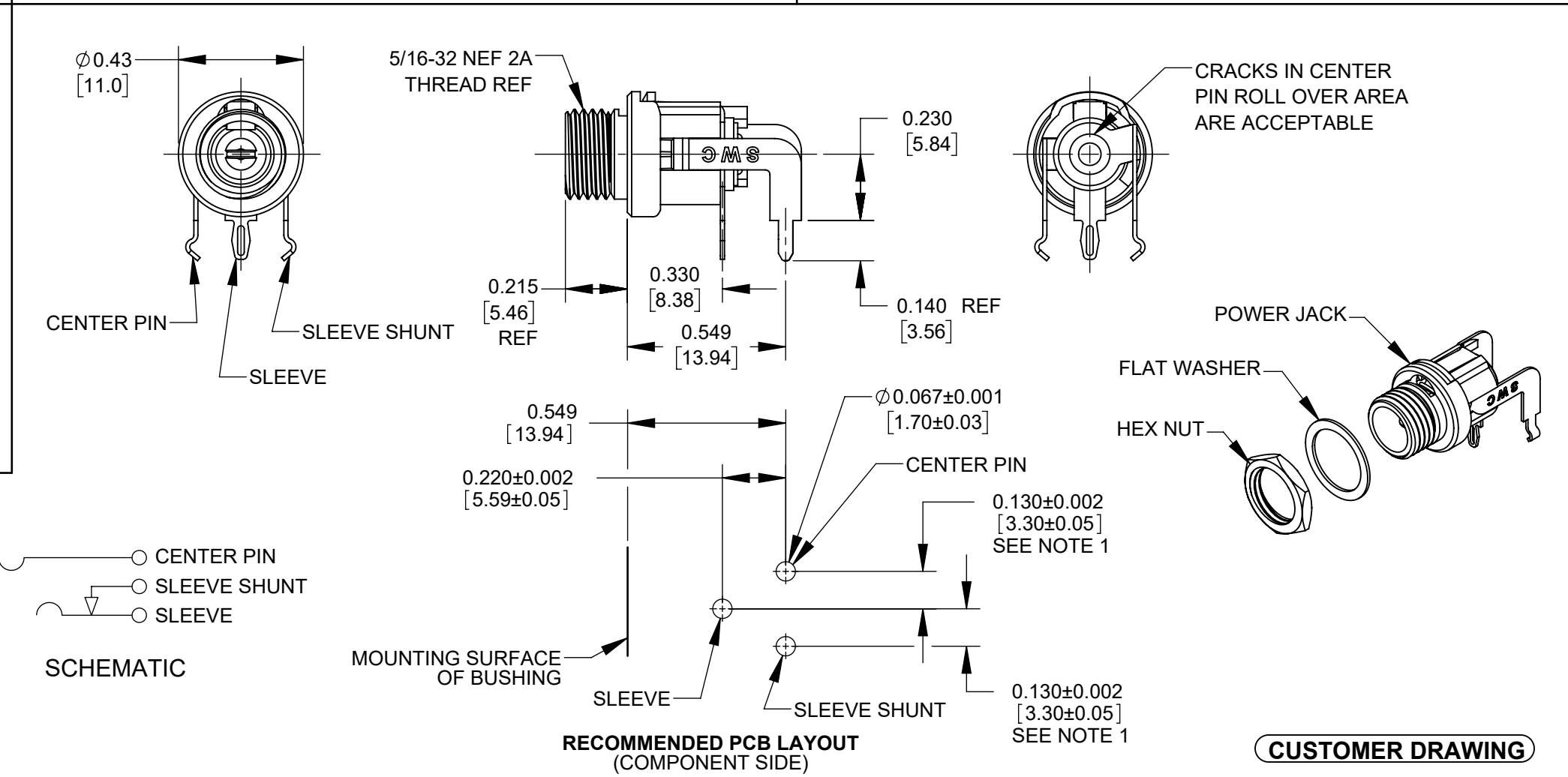

- NOTES:
- FOR HAND INSERTION USE SPACING 0.130 [3.30]
FOR AUTOMATED INSERTION USE SPACING 0.135 [3.43]
 - HEX NUT AND FLAT WASHER SUPPLIED UNASSEMBLED.
 - MATERIAL:
HOUSING, HEX NUT - COPPER ALLOY, NICKEL PLATED
INSULATOR HOUSING - THERMOPLASTIC
TERMINAL INSULATORS - PHENOLIC
FLAT WASHER - STEEL, NICKEL PLATED
PIN, SPRING, TERMINALS - COPPER ALLOY, SILVER PLATED
 - IT IS RECOMMENDED THAT THE JACK MOUNTING NUT BE TIGHTENED SNUG BY HAND BEFORE APPLYING A FINAL TIGHTENING TORQUE OF 8-10 IN-LBS USING HAND TOOLS ONLY. POWER DRIVER OR IMPACT DRIVERS ARE NOT RECOMMENDED.
 - THESE PRODUCTS ARE RoHS COMPLIANT

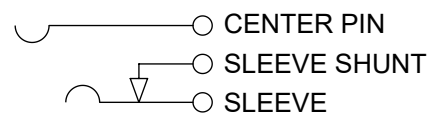

SCHEMATIC

RECOMMENDED PCB LAYOUT (COMPONENT SIDE)

CUSTOMER DRAWING

REV	ECO NUMBER	DATE	BY	APVD
A	28408	03-08-22	PC	TJK
REVISIONS				

UNLESS OTHERWISE SPECIFIED

1. ALL DIMENSIONS IN INCHES [mm]
- TWO PLACE DECIMALS ±0.02 [0.5]
- THREE PLACE DECIMALS ±0.005 [0.13]

DO NOT SCALE DRAWING

THIS DRAWING DESCRIBES A DESIGN CONSIDERED PROPRIETARY IN NATURE, DEVELOPED AND MANUFACTURED BY SWITCHCRAFT INC. AND IS RELEASED ON A CONFIDENTIAL BASIS FOR IDENTIFICATION PURPOSES ONLY.									
SIZE	WIDTH	MULT	LBS/M	TEMPER					
FINISH SPEC No.					MATERIAL SPEC No.				
FIRST USED ON					SCALE 2:1				
DATE DRAWN	BY	CHKD	APVD						
4-16-2020	SRC	TJK	TJK						
			05-10-22	05-10-22					
NAME HIGH TEMP POWER JACKS RIGHT-ANGLE LOW PROFILE, RoHS								PART No. 7__RAHLP SERIES	
								REV A	