

# Using the UCD3138ALLCEVM150

## User's Guide



Literature Number: SLUUB97A  
March 2015–Revised January 2016



## **WARNING**

Always follow TI's set-up and application instructions, including use of all interface components within their recommended electrical rated voltage and power limits. Always use electrical safety precautions to help ensure your personal safety and the safety of those working around you. Contact TI's Product Information Center <http://support/ti.com> for further information.

**Save all warnings and instructions for future reference.**

**Failure to follow warnings and instructions may result in personal injury, property damage, or death due to electrical shock and/or burn hazards.**

The term TI HV EVM refers to an electronic device typically provided as an open framed, unenclosed printed circuit board assembly. It is intended strictly for use in development laboratory environments, solely for qualified professional users having training, expertise, and knowledge of electrical safety risks in development and application of high-voltage electrical circuits. Any other use and/or application are strictly prohibited by Texas Instruments. If you are not suitably qualified, you should immediately stop from further use of the HV EVM.

### **1. Work Area Safety:**

- (a) Keep work area clean and orderly.
- (b) Qualified observer(s) must be present anytime circuits are energized.
- (c) Effective barriers and signage must be present in the area where the TI HV EVM and its interface electronics are energized, indicating operation of accessible high voltages may be present, for the purpose of protecting inadvertent access.
- (d) All interface circuits, power supplies, evaluation modules, instruments, meters, scopes and other related apparatus used in a development environment exceeding 50 V<sub>RMS</sub>/75 VDC must be electrically located within a protected Emergency Power Off (EPO) protected power strip.
- (e) Use a stable and non-conductive work surface.
- (f) Use adequately insulated clamps and wires to attach measurement probes and instruments. No freehand testing whenever possible.

### **2. Electrical Safety:**

- (a) De-energize the TI HV EVM and all its inputs, outputs, and electrical loads before performing any electrical or other diagnostic measurements. Revalidate that TI HV EVM power has been safely de-energized.
- (b) With the EVM confirmed de-energized, proceed with required electrical circuit configurations, wiring, measurement equipment hook-ups and other application needs, while still assuming the EVM circuit and measuring instruments are electrically live.
- (c) Once EVM readiness is complete, energize the EVM as intended.

**WARNING: while the EVM is energized, never touch the EVM or its electrical circuits as they could be at high voltages capable of causing electrical shock hazard.**

### **3. Personal Safety:**

- (a) Wear personal protective equipment e.g. latex gloves and/or safety glasses with side shields or protect EVM in an adequate lucent plastic box with interlocks from accidental touch.

### **4. Limitation for Safe Use:**

- (a) EVMs are not to be used as all or part of a production unit.



# Digitally Controlled LLC Resonant Half-Bridge DC-to-DC Converter

## 0.1 Introduction

The UCD3138ALLCEVM150 EVM helps evaluate the UCD3138A 64-pin digital control device in an off-line power converter application and then to aid in its design. The EVM is a standalone LLC resonant half-bridge DC-to-DC power converter. The EVM is used together with its control card, the UCD3138ACCEVM149 EVM. The UCD3138ARGC is placed on the UCD3138ACCEVM149 EVM.

The UCD3138ALLCEVM150 and UCD3138ACCEVM149 devices can be used as delivered without additional work, from either hardware or firmware, to evaluate an LLC resonant half-bridge DC-to-DC converter. This EVM combination allows for some of its design parameters to be returned using a GUI based tool, called [Texas Instruments Fusion Digital Power Designer](#). It is also possible to load custom firmware with user's own definition and development.

The two EVMs included are the UCD3138ALLCEVM150 and the UCD3138ACCEVM149.

This user's guide provides basic evaluation instruction from a viewpoint of system operation in a standalone LLC resonant half-bridge DC-to-DC power converter.

### **WARNING**

- High voltages are present on this evaluation module during operation and for a while even after power off. This module should only be tested by skilled personnel in a controlled laboratory environment.
- An isolated DC voltage source meeting IEC61010 reinforced insulation standards is recommended for evaluating this EVM.
- High temperature exceeding 60°C may be found during EVM operation and for a while even after power off.
- This EVM's purpose is to facilitate the evaluation of digital control in an LLC using the UCD3138A, and cannot be tested and treated as a final product.
- Extreme caution should be taken to eliminate the possibility of electric shock and heat burn.
- Read and understand this user's guide thoroughly before starting any physical evaluation.

## 0.2 Description

The UCD3138ALLCEVM150 and UCD3138ACCEVM149 demonstrate an LLC resonant half-bridge DC-DC power converter with digital control using the UCD3138A device. The UCD3138A device is located on the UCD3138ACCEVM149 board. The UCD3138ACCEVM149 is a daughter card with preloaded firmware that provides the required control functions for an LLC converter. For details of the firmware please contact TI. UCD3138ALLCEVM150 accepts a DC input from 350 V<sub>DC</sub> to 400 V<sub>DC</sub>, and outputs a nominal 12 V<sub>DC</sub> with full load output power of 340 W, or full output current of 29 A.

---

**NOTE:** This EVM does not have an input fuse and relies on the input current limit from the input voltage source used.

---

### 0.2.1 Typical Applications

- Offline DC-to-DC Power Conversion
- Servers
- Telecommunication Systems

### 0.2.2 Features

- Digitally Controlled LLC Resonant Half-Bridge DC-to-DC Power Conversion
- DC Input from 350 V<sub>DC</sub> to 400 V<sub>DC</sub>
- 12 V<sub>DC</sub> Regulated Output from No Load to Full Load
- Full-Load Power 340 W, or Full-Load Current 29 A
- High Efficiency
- Constant Soft-Start Time
- Protection: Over Voltage, Over Current, Brownout and Output Short-Circuit Protection
- Test Points to Facilitate Device and Topology Evaluation
- Synchronous Rectification
- Automatic Mode Switching between LLC Mode and PWM Mode
- Cycle-by-Cycle Current Limiting with Duty Cycle Matching
- Constant Current and Constant Power Control Mode
- PMBUS Communication
- Current Sharing Capability (GUI Enable), Across Paralleled Units

### 0.3 Performance Specifications

**Table 0-1. UCD3138ALLCEVM150 Performance Specifications**

PARAMETER	TEST CONDITIONS	MIN	TYP	MAX	UNITS
<b>Input Characteristics</b>					
Voltage operation range		350		400	$V_{DC}$
Input UVLO On			325		
Input UVLO Off			310		
Input current	Input = 350 $V_{DC}$ , full load = 29 A			1.2	A
Input current	Input = 380 $V_{DC}$ , full load = 29 A			1.1	
Input current	Input = 400 $V_{DC}$ , full load = 29 A			1.0	
<b>Output Characteristics</b>					
Output voltage, $V_{OUT}$	No load to full load		12		VDC
Output load current, $I_{OUT}$	350 $V_{DC}$ to 400 $V_{DC}$			29	A
Output voltage ripple	380 $V_{DC}$ and full load = 29 A		200		mVpp
Output over current	Operation 10s then latch-off shutdown	30			A
<b>Systems Characteristics</b>					
Switching frequency	Resonant mode	35		150	kHz
	PWM Mode		150		
Peak efficiency	380 $V_{DC}$ , full load = 29 A		94.85%		
Full-load efficiency	380 $V_{DC}$ , load = 20 A		94.20%		
Operating temperature	Natural convection		25		$^{\circ}C$
<b>Firmware</b>					
Device ID (version)	UCD3138A				
Filename	3138ALLCEVM_150_150205.x0				

## 0.4 Schematics

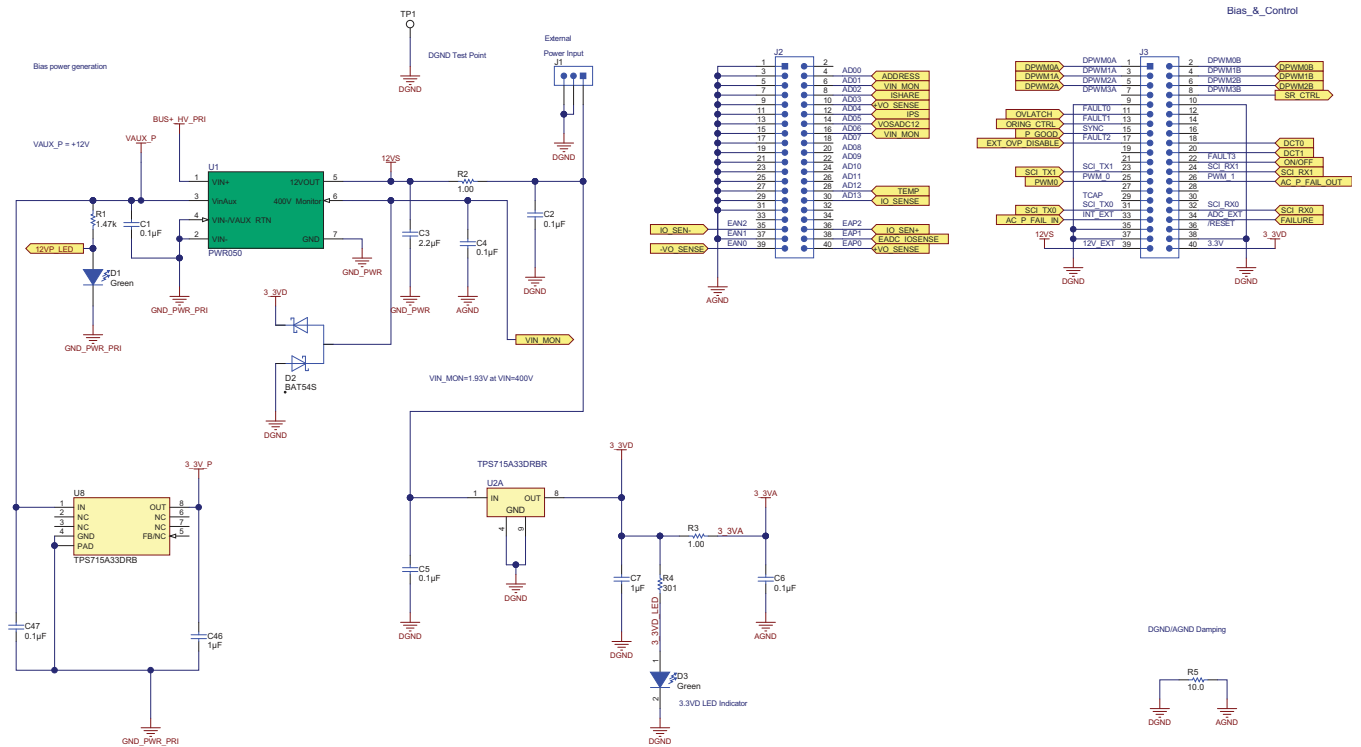

Figure 0-1. UCD3138ALLCEVM150 Schematics (1 of 9)

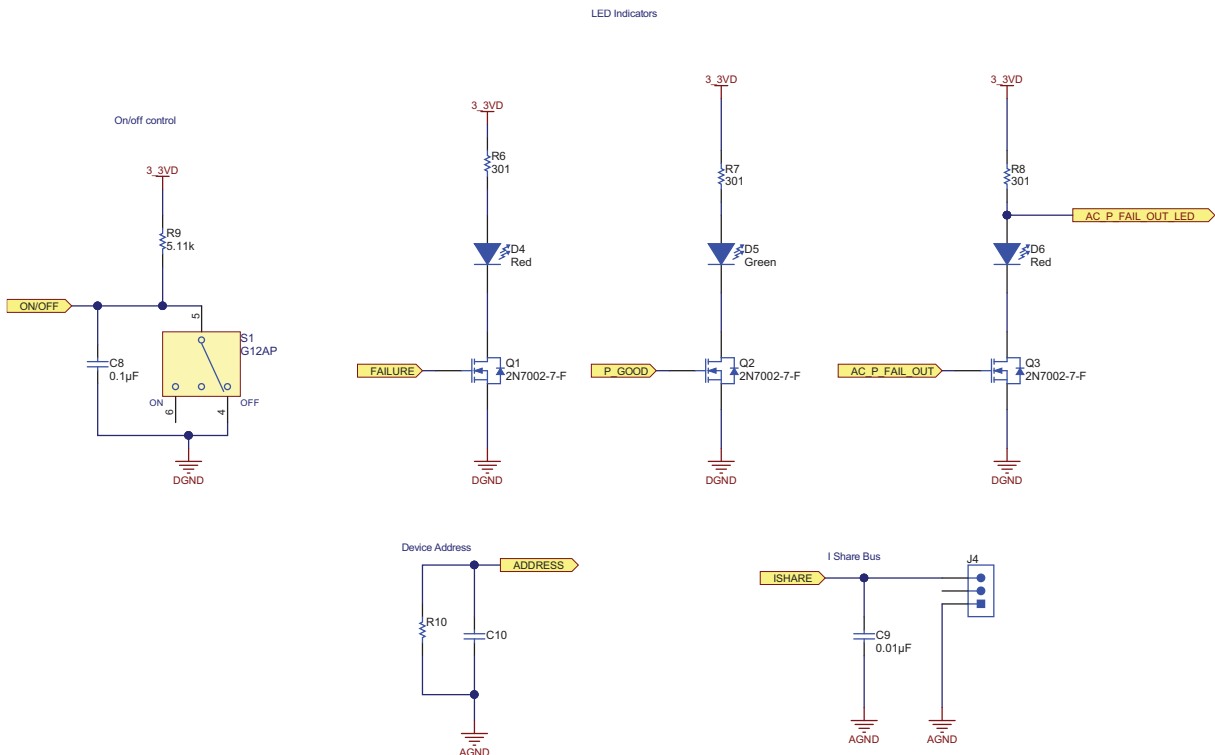

Figure 0-2. UCD3138ALLCEVM150 Schematics (2 of 9)

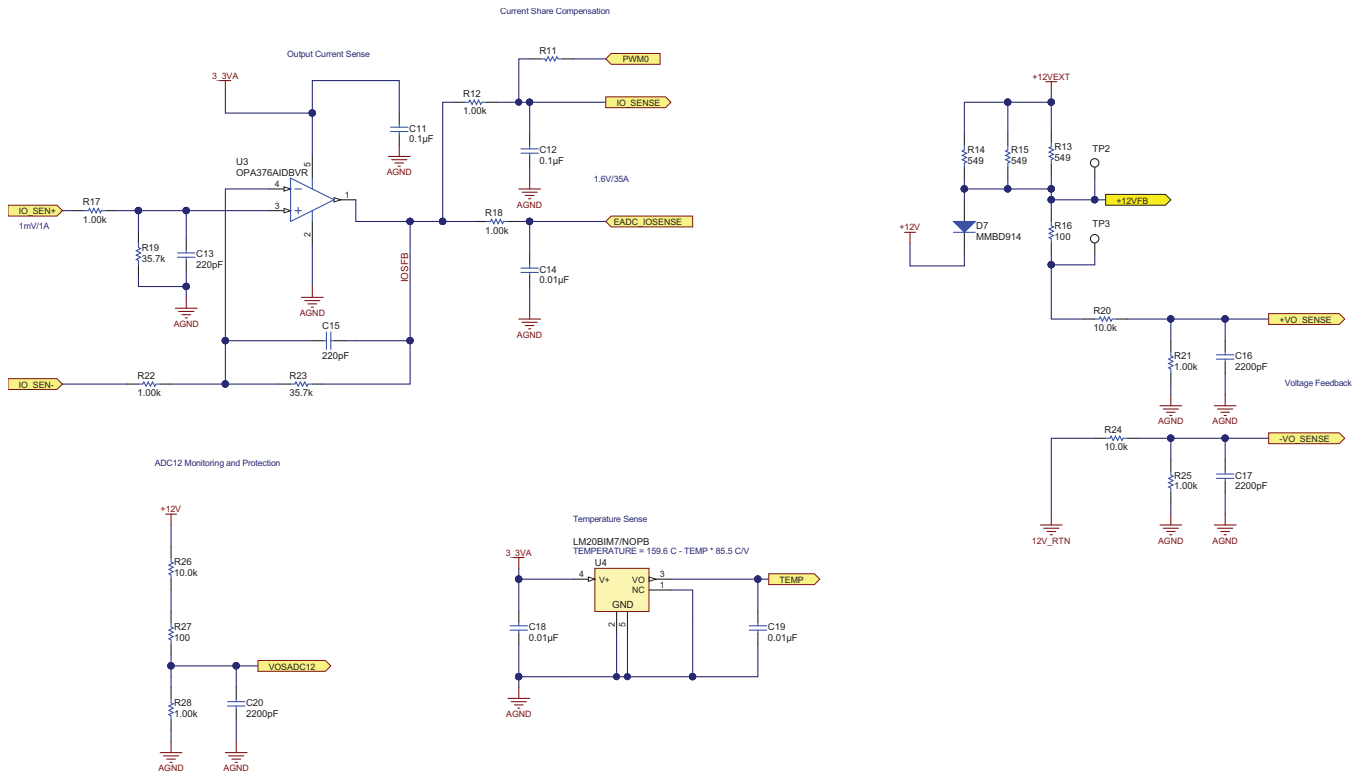

Figure 0-3. UCD3138ALLCEVM150 Schematics (3 of 9)

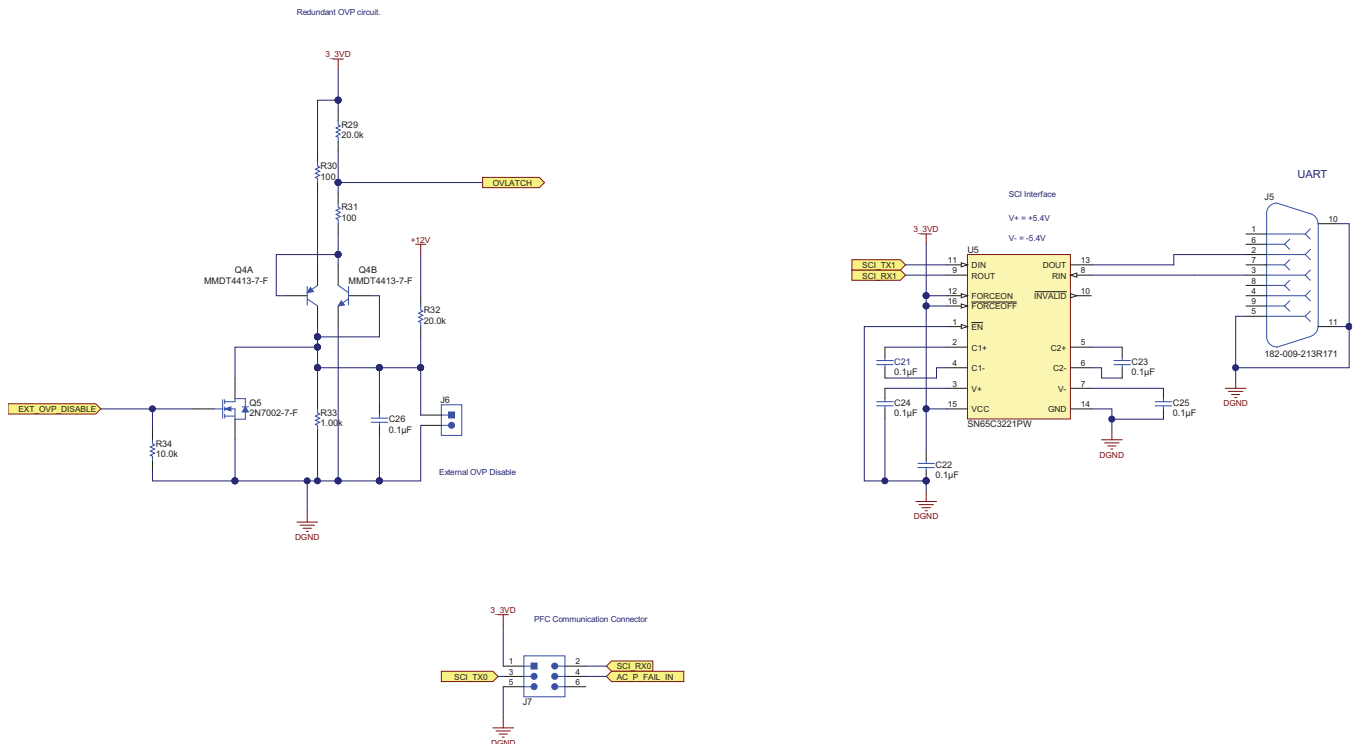

Figure 0-4. UCD3138ALLCEVM150 Schematics (4 of 9)

VIN = 350 to 400VDC, Iin max = 1.5A.

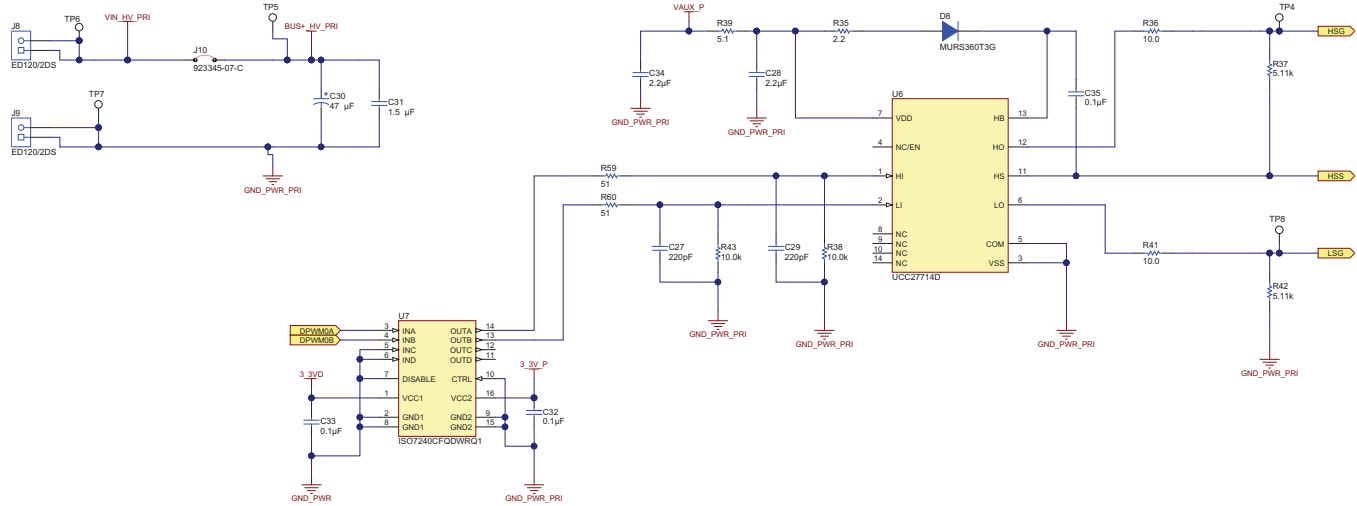

Figure 0-5. UCD3138ALLCEVM150 Schematics (5 of 9)

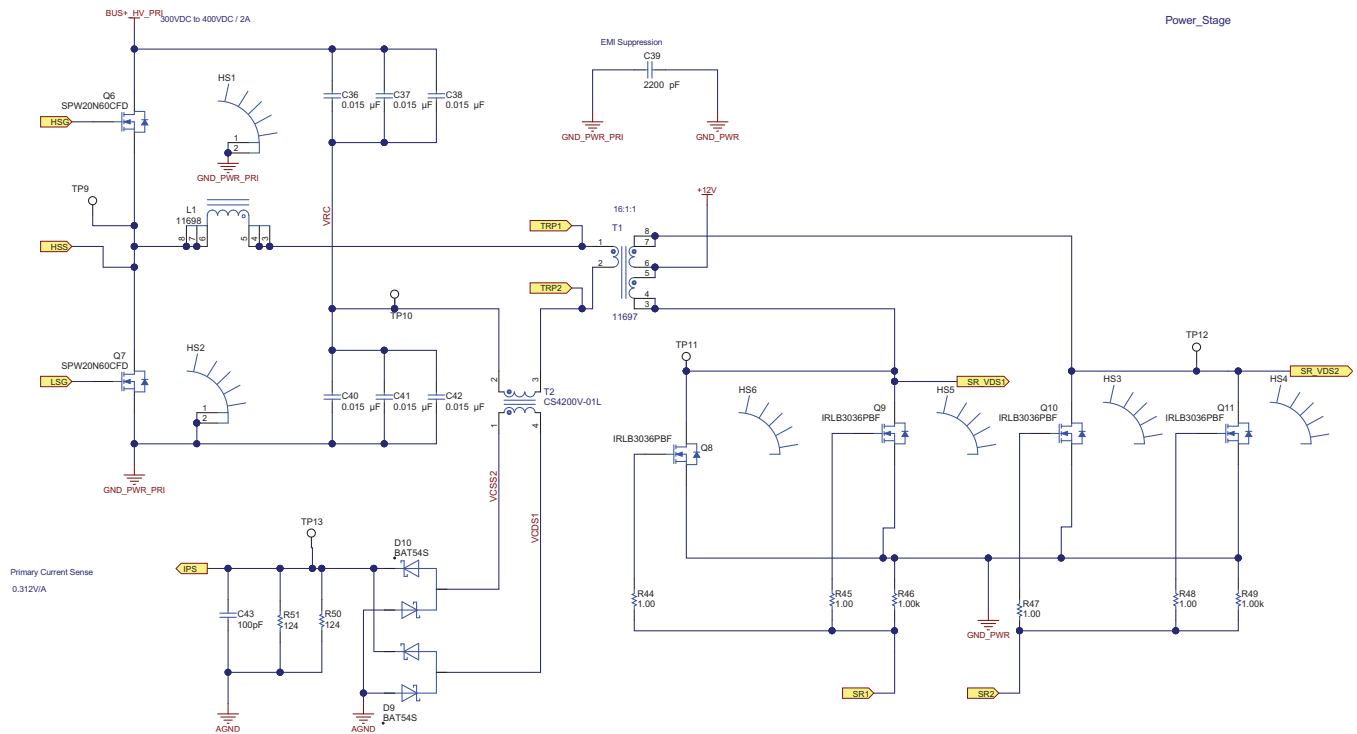

Figure 0-6. UCD3138ALLCEVM150 Schematics (6 of 9)



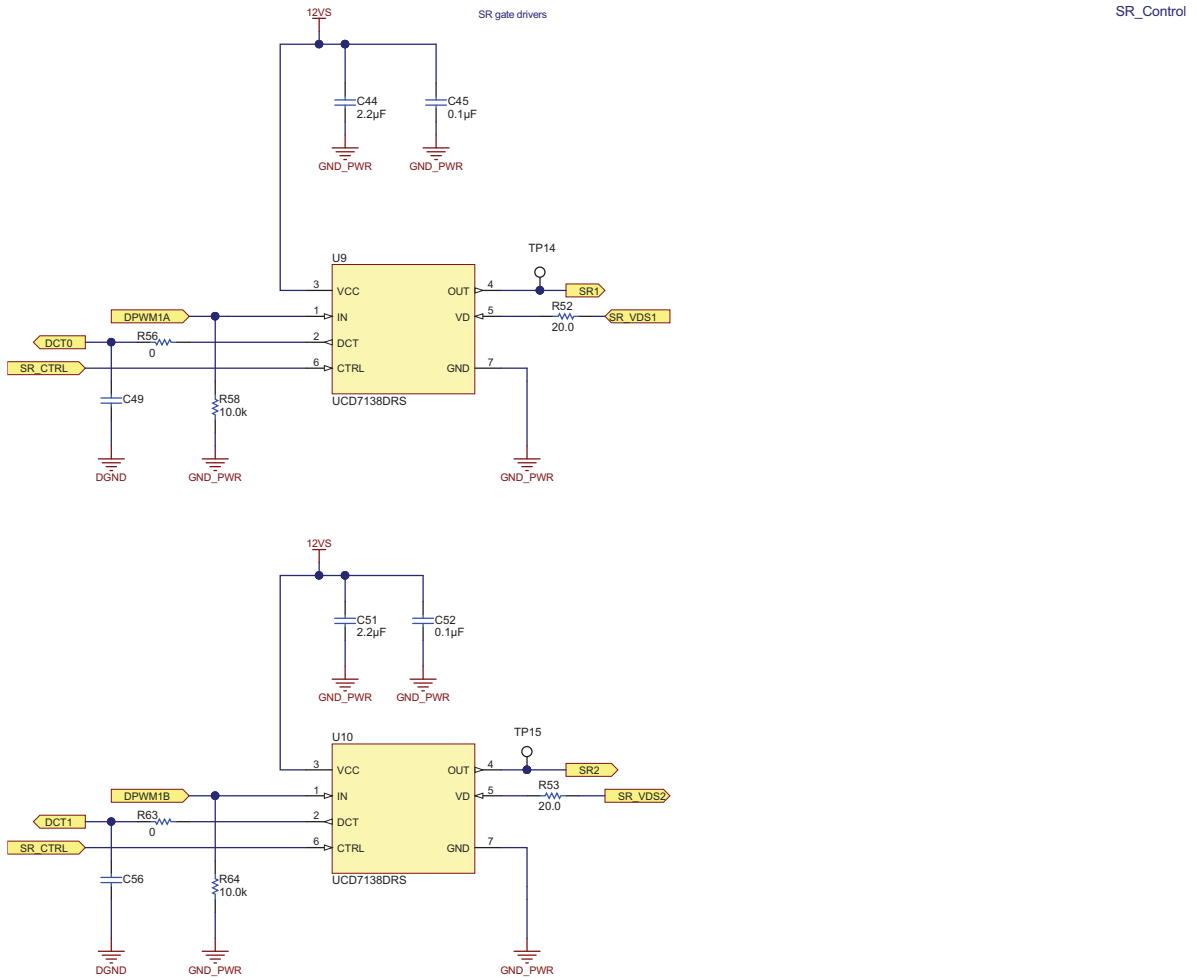

Figure 0-7. UCD3138ALLCEVM150 Schematics (7 of 9)

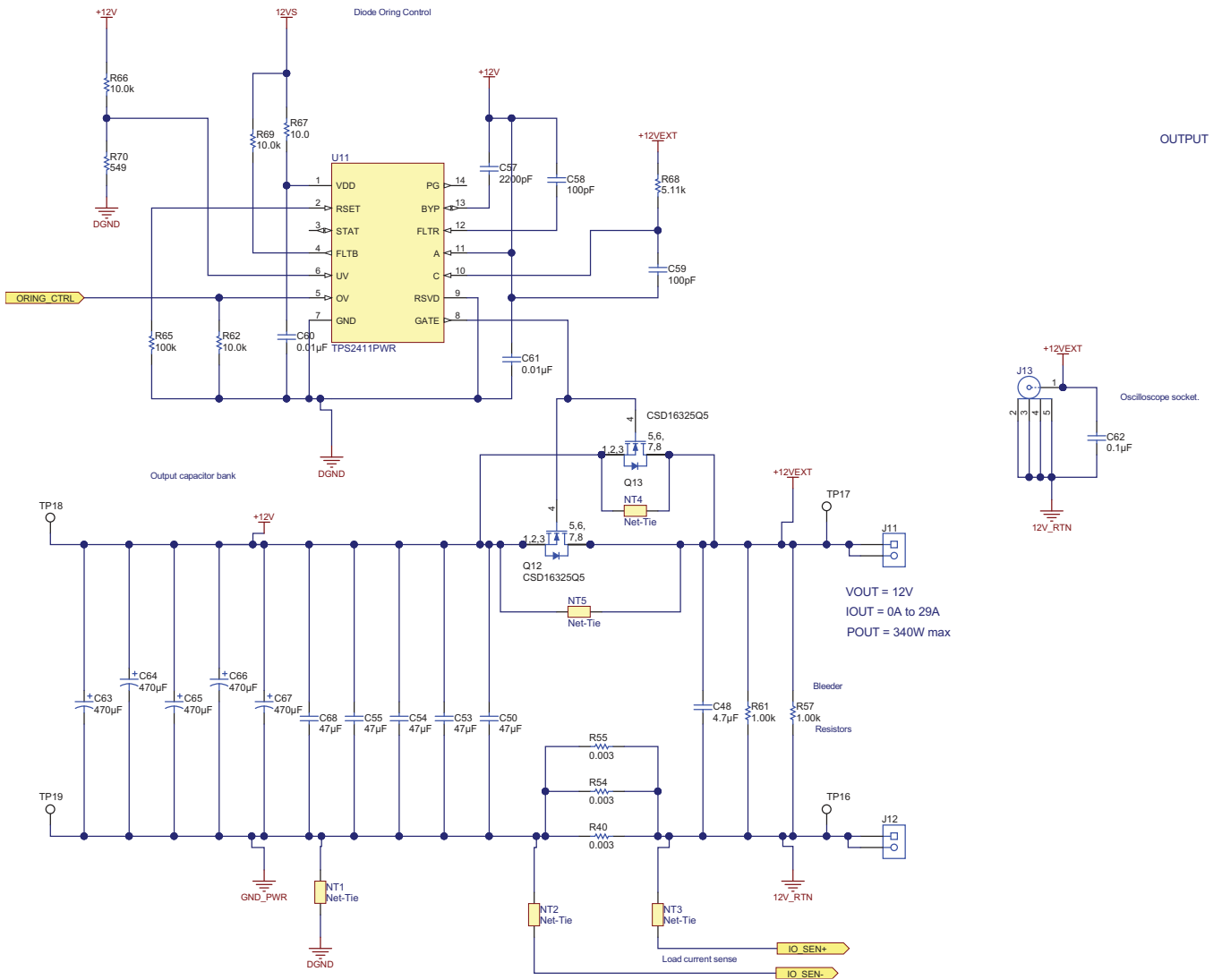
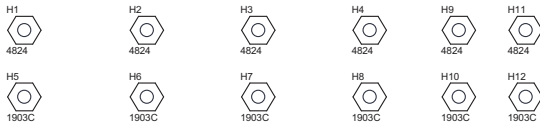

Figure 0-8. UCD3138ALLCEVM150 Schematics (8 of 9)



PCB Number:SV601150  
 PCB Rev:A

PCB LOGO  
 Texas Instruments



PCB LOGO  
 FCC disclaimer



PCB LOGO  
 CAUTION, READ USER GUIDE BEFORE USE

PCB LOGO  
 Pb-Free Symbol



**ZZ1**

**Assembly Note**

These assemblies are ESD sensitive, ESD precautions shall be observed.

**ZZ2**

**Assembly Note**

These assemblies must be clean and free from flux all contaminants. Use of no clean flux is not applicable.

**ZZ3**

**Assembly Note**

These assemblies must comply with workmanship standards IPC-A-610 Class 2, unless otherwise specified.

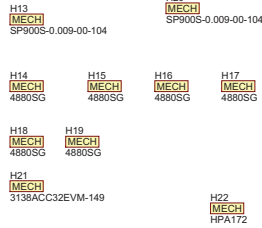

**Figure 0-9. UCD3138ALLCEVM150 Schematics (9 of 9)**

## 0.5 Test Setup

### 0.5.1 Test Equipment

**DC Voltage Source:** capable of 350 V<sub>DC</sub> to 400 V<sub>DC</sub>, adjustable, with minimum power rating of 400 W, or current rating not less than 1.5 A, with current limit function. The DC voltage source to be used should meet IEC61010 safety requirements.

**DC Multimeter:** One unit capable of 0-V<sub>DC</sub> to 400-V<sub>DC</sub> input range, four digits display preferred; and one unit capable of 0-V<sub>DC</sub> to 15-V<sub>DC</sub> input range, four digits display preferred.

**Output Load:** DC load capable of receiving 0 V<sub>DC</sub> to 15 V<sub>DC</sub>, 0 A to 30 A, and 0 W to 360 W or greater, with display such as load current and load power.

Current-meter, DC, optional in case the load has no display, one unit, capable of 0 A to 30 A. A low ohmic shunt and DMM are recommended.

**Oscilloscope:** capable of 500-MHz full bandwidth, digital or analog, if digital 5 Gs/s or better.

**Fan:** 200 LFM to 400 LFM forced air cooling is recommended, but not a must.

**Recommended Wire Gauge:** capable of 30 A, or better than number 14 AWG, with the total length of wire less than 8 feet (a four foot input and a four foot return).

### 0.5.2 Recommended Test Setup

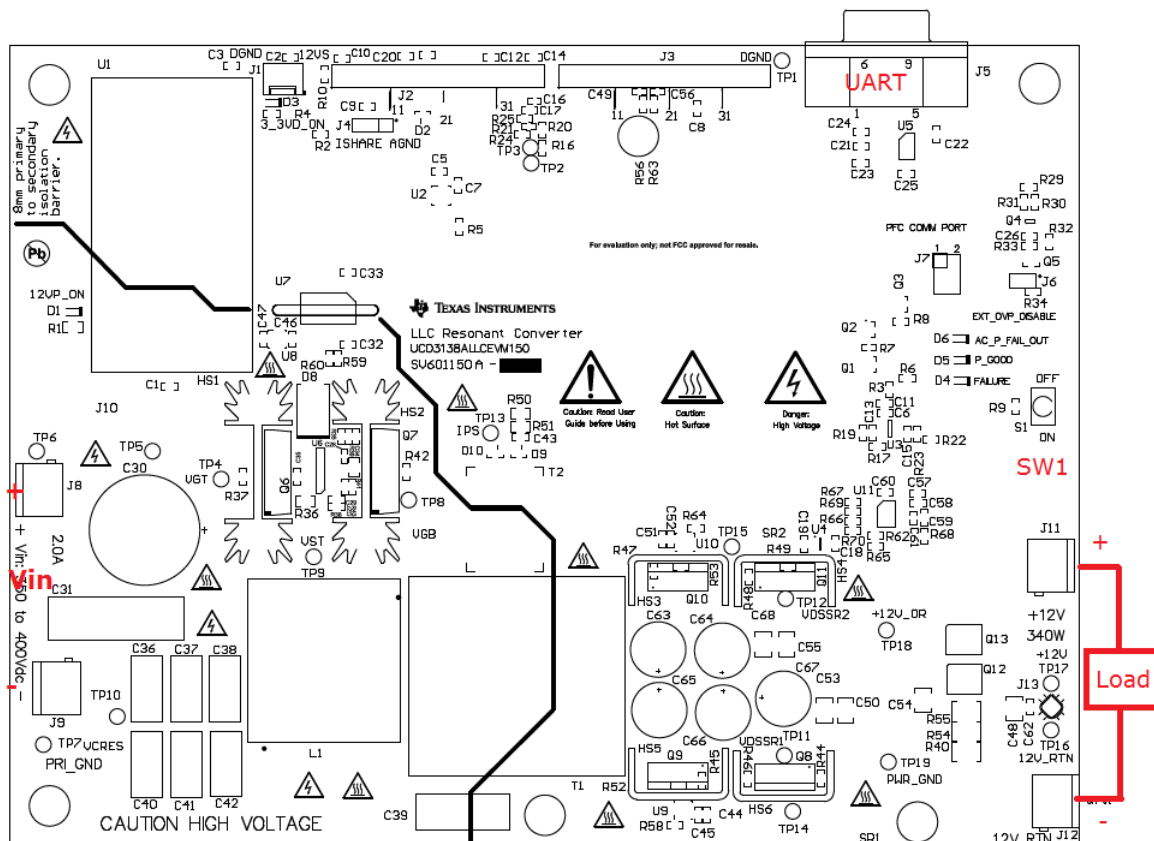

Figure 0-10. UCD3138ALLCEVM150 Recommended Test Set Up

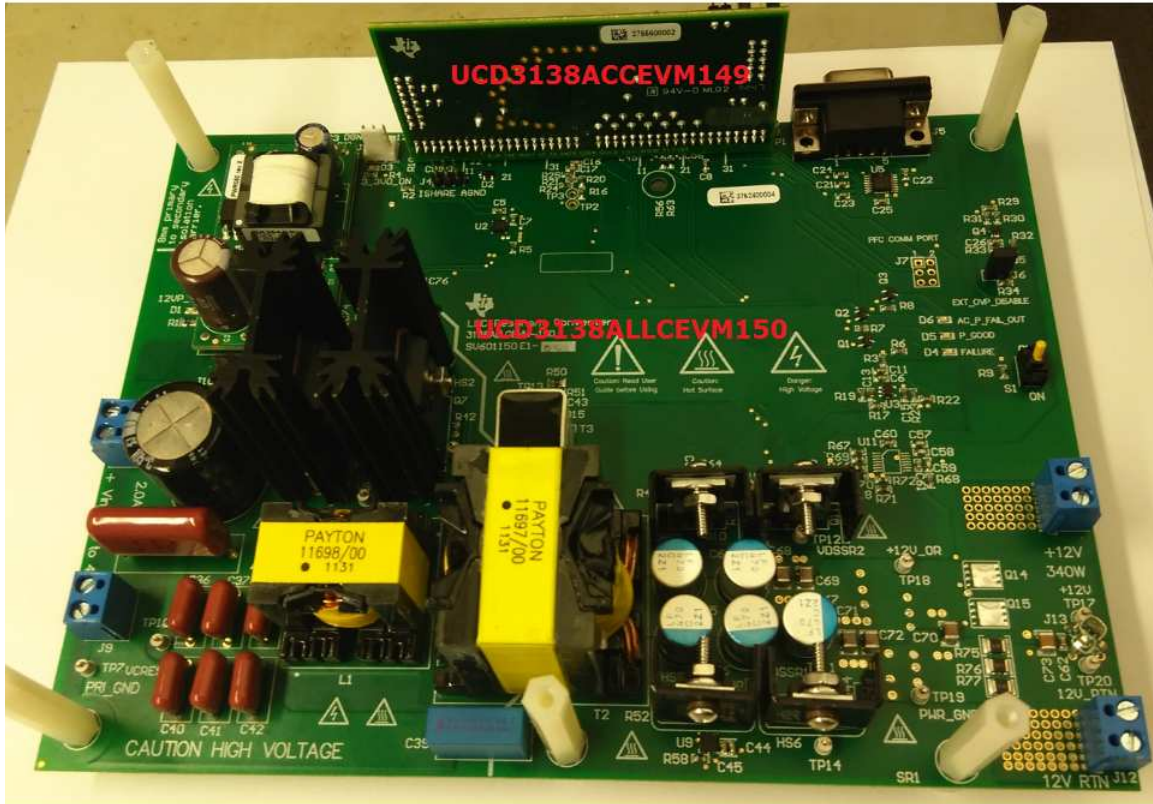

Figure 0-11. Orientation of Board UCD3138ACCEVM149 on Board UCD3138ALLCEVM150

## 0.6 List of Test Points

**Table 0-2. UCD3138ACCEVM149 Test Points**

TEST POINTS	NAME	DESCRIPTION
TP1	DGND	Digital GND
TP2	Not Used	
TP3	Not Used	
TP4	HSG	Primary high-side MOSFET gate, Q6
TP5	Input +	Input + after jumper J10
TP6	Input_P	Input voltage positive terminal
TP7	Input_N	Input voltage return terminal
TP8	LSG	Primary low-side MOSFET gate, Q7
TP9	HSS	Primary-side switch node, or the intersection of Q6 and Q7
TP10	SWC	Primary side, the intersection of bridge capacitors
TP11	SR_VDS1	Drain of secondary side sync FET Q8 and Q9
TP12	SR_VDS2	Drain of secondary side sync FET Q10 and Q11
TP13	IPS	Primary current sense
TP14	SR1	SR gate drive to Q8 and Q9
TP15	SR2	SR gate drive to Q10 and Q11
TP16	Vo_N	Output voltage return
TP17	Vo_P	Output voltage positive terminal
TP18	Xmer_C	Power transformer center point of the secondary side windings.
TP19	GND_PWR	Power GND

## 0.7 List of Terminals

**Table 0-3. List of Terminals**

TERMINAL	NAME	DESCRIPTION
J1	Bias Input	3 pin, external power input, 12 V
J2	Analog Signal	40-pin header, analog signal to control card (UCD3138ACCEVM149)
J3	Digital Signal	40-pin header, digital signal to control card
J4	I-Share	Current share bus connector, 3-pin
J5	UART1	Standard UART connection, RS232, 9 pin
J6	OVP-1	2-pin header, jump across to disable external OVP
J7	Not Used	
J8	Input_P	Input voltage positive terminal
J9	Input_N	Input voltage return terminal
J10	Jumper	Reserved to an input fuse substitution
J11	Output_P	Output voltage positive terminal
J12	Output_N	Output voltage return terminal
J13	Vout	Oscilloscope socket

## 0.8 Test Procedure

### 0.8.1 Efficiency Measurement Procedure

#### **WARNING**

- Danger of electrical shock! High voltage present during the measurement.
- Do not leave EVM powered when unattended.
- Danger of heat burn from high temperature.

1. Refer to [Figure 0-10](#) for basic set up to measure power conversion efficiency. The required equipment for this measurement is listed in [Section 0.5.1](#).
2. Before making electrical connections, visually check the boards to make sure no shipping damage occurred.
3. In this EVM package, two EVMs are included, UCD3138ALLCEVM150, and the UCD3138ACCEVM149. For this measurement, the UCD3138ALLCEVM150 and UCD3138ACCEVM149 boards are needed.
4. First install the UCD3138ACCEVM149 board onto the UCD3138ALLCEVM150. Care must be taken with the alignment and orientation of the two boards, or damage may occur. Refer to [Figure 0-11](#) for UCD3138ACCEVM149 board orientation.
5. Connect the DC voltage source to J8 (+) and J9 (-). The DC voltage source should be isolated and meet IEC61010 requirements. Set up the DC output voltage in the range specified in [Table 0-1](#), between 350 V<sub>DC</sub> and 400 V<sub>DC</sub>; set up the DC source current limit 1.2 A.

---

**NOTE:** The board has no fuse installed and relies on the external voltage source current limit for circuit protection.

---

6. Connect an electronic load with either constant-current mode or constant-resistance mode. The load range is from zero to 29 A.
7. Check and make sure a jumper is installed on J6.
8. It is recommended to use the switch SW1 to turn on the board output after the input voltage is applied to the board. Before applying input voltage, make sure the switch, SW1, is in the *OFF* position.
9. If the load does not have a current or a power display, a current meter or low ohmic shunt and DMM is needed between the load and the board for current measurements.
10. Connect a volt-meter across the output connector and set the volt-meter scale 0 V to 15 V on its voltage, DC.
11. Turn on the DC voltage source output, flip SW1 to *ON* and vary the load. Record output voltage and current measurements.

### 0.8.2 Equipment Shutdown

1. Shut down the DC voltage source.
2. Shut down the electronic load.

## 0.9 Performance Data and Typical Characteristic Curves

Figure 0-12 through Figure 0-25 present typical performance curves for UCD3138ALLCEVM150.

### 0.9.1 Efficiency

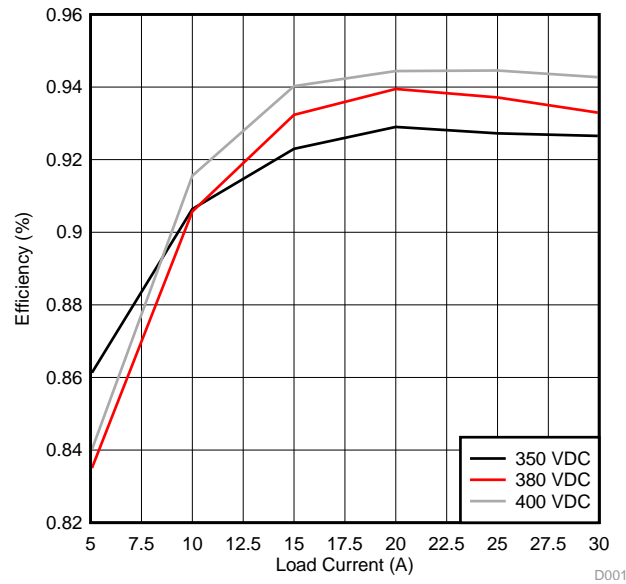

**Figure 0-12. UCD3138ALLCEVM150 Efficiency**

### 0.9.2 Load Regulation

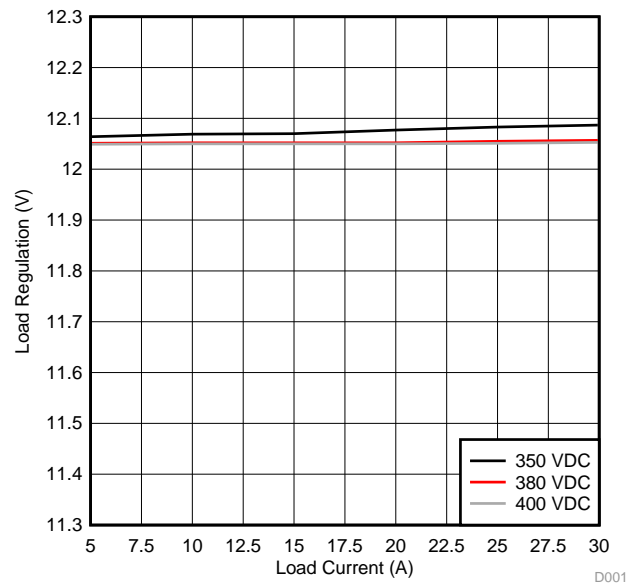

**Figure 0-13. UCD3138ALLCEVM150 Load Regulation**



### 0.9.3 Switching Frequency Control

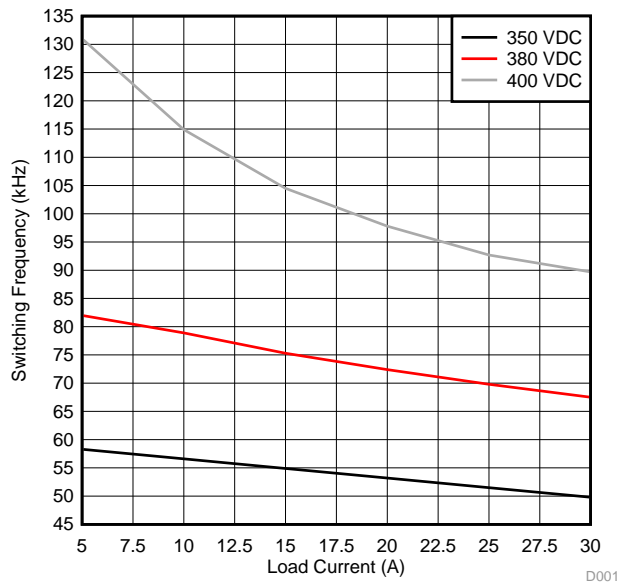

Figure 0-14. Switching Frequency Control in LLC Mode

### 0.9.4 Load Operation with LLC and PWM

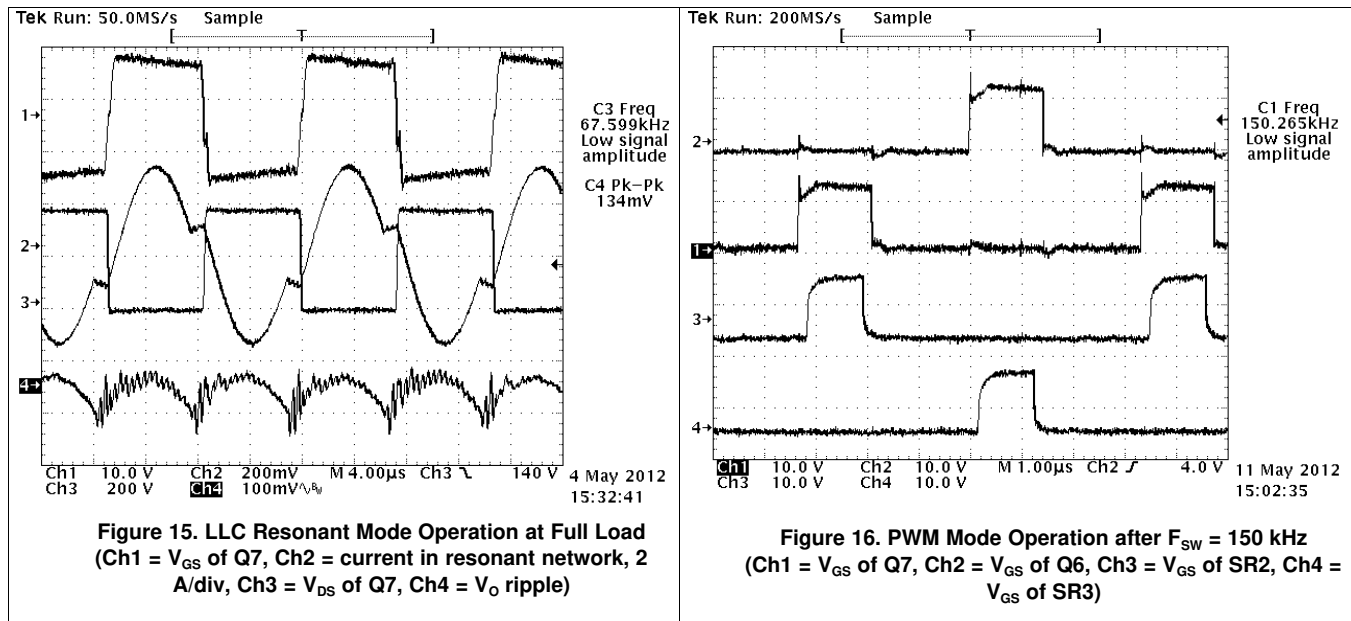
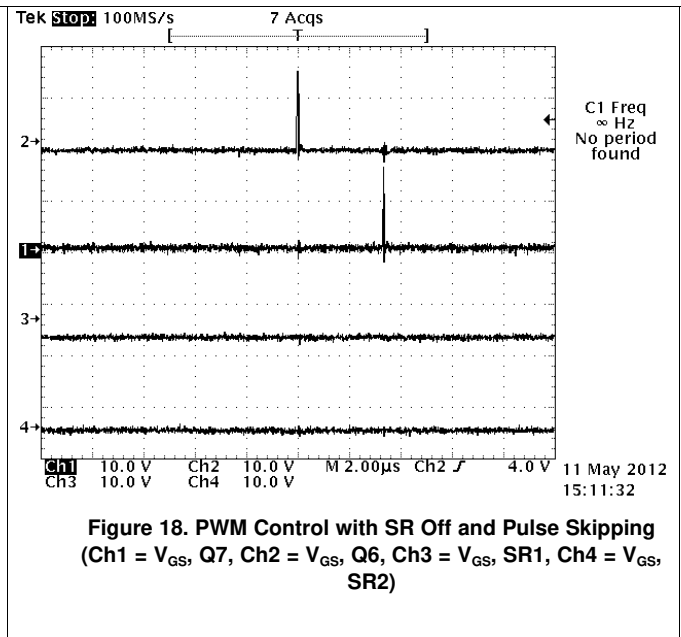
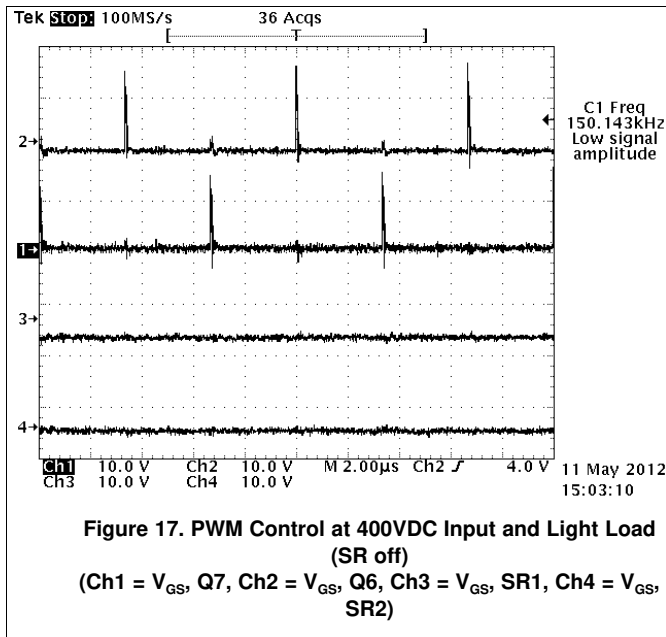

Figure 15. LLC Resonant Mode Operation at Full Load (Ch1 =  $V_{GS}$  of Q7, Ch2 = current in resonant network, 2 A/div, Ch3 =  $V_{DS}$  of Q7, Ch4 =  $V_o$  ripple)

Figure 16. PWM Mode Operation after  $F_{SW} = 150$  kHz (Ch1 =  $V_{GS}$  of Q7, Ch2 =  $V_{GS}$  of Q6, Ch3 =  $V_{GS}$  of SR2, Ch4 =  $V_{GS}$  of SR3)

### 0.9.5 Very Light-Load Operation at High Line of Input



### 0.9.6 Output Voltage Ripple

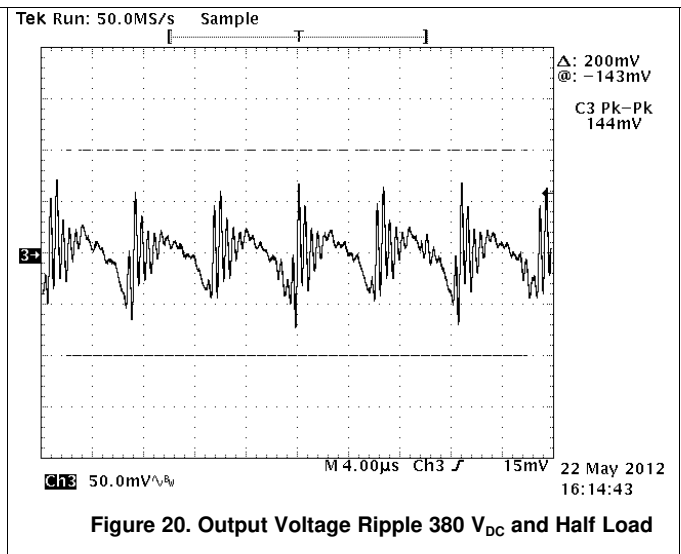
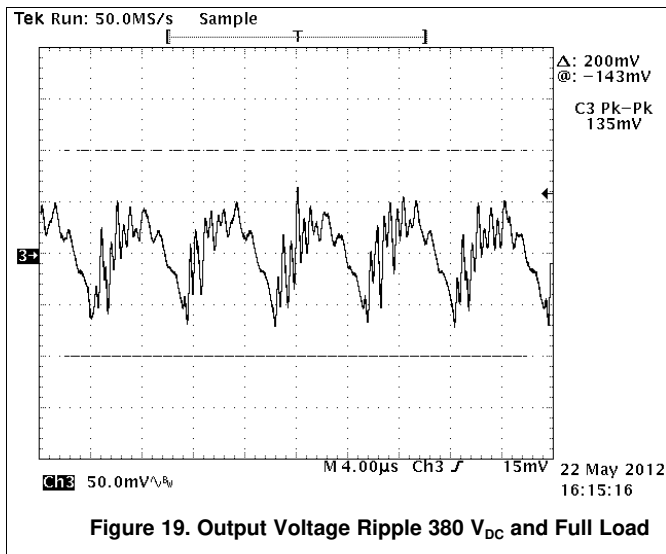

### 0.9.7 Output Turn On

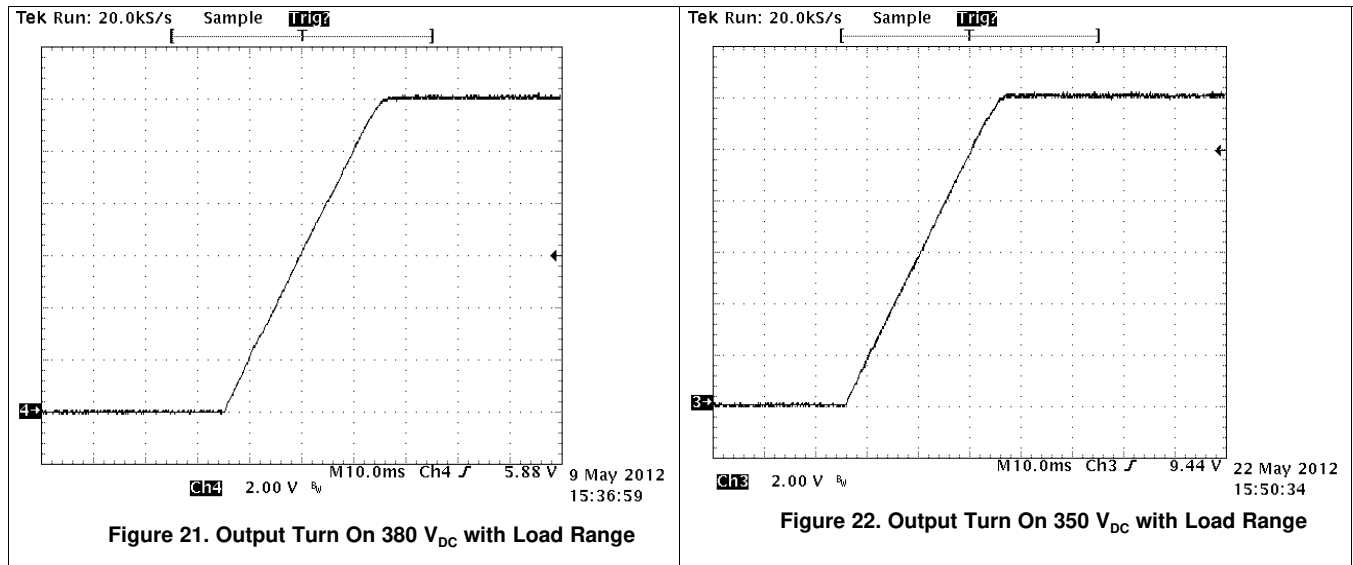

### 0.9.8 Other Waveforms

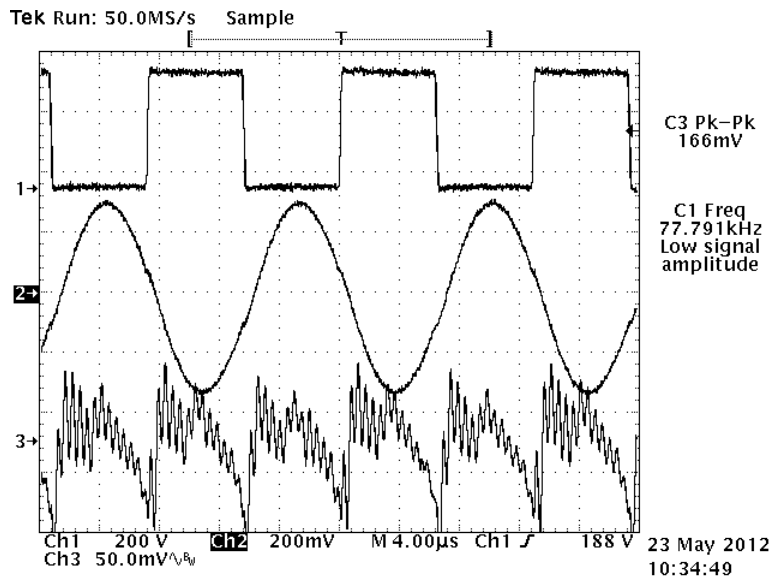
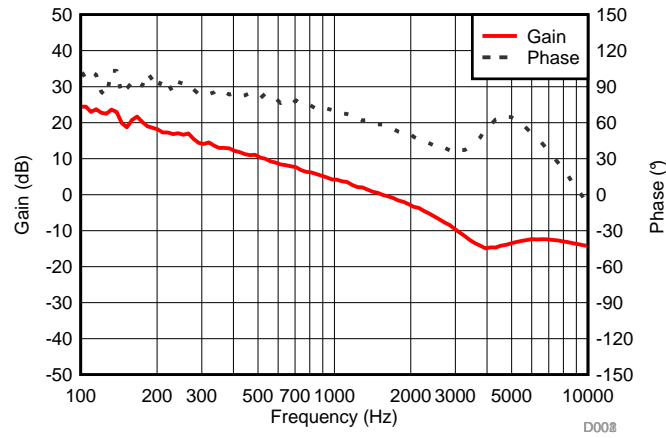
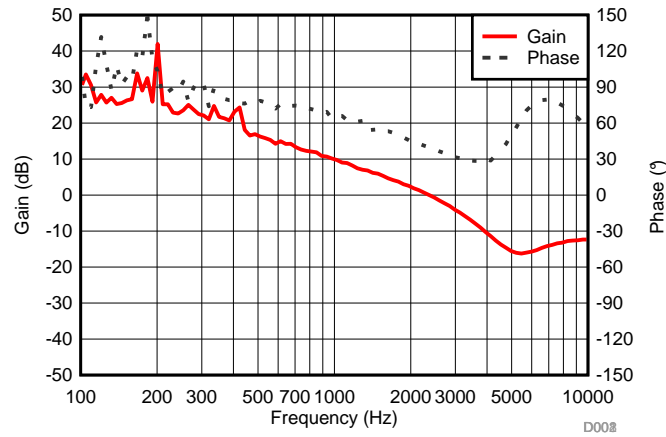

Figure 0-23. 380 V<sub>DC</sub> and 30 A Before OCP Latch-Off Shutdown (Ch1 = V<sub>DS</sub> of Q7, Ch2 = current of resonant network, Ch3 = V<sub>o</sub> ripple)



**Figure 0-24. Control Loop Bode Plots at 380 V<sub>DC</sub> and Full Load**



**Figure 0-25. Control Loop Bode Plots at 400 V<sub>DC</sub> and Full Load**

### 0.10 EVM Assembly Drawing and PCB layout

The following figures (Figure 0-26 through Figure 0-31) show the design of the UCD3138ALLCEVM150 printed circuit board. PCB dimensions: L x W = 8.0 inch x 6.0 inch, PCB material: FR4 or compatible, four layers and 2-ounce copper on each layer

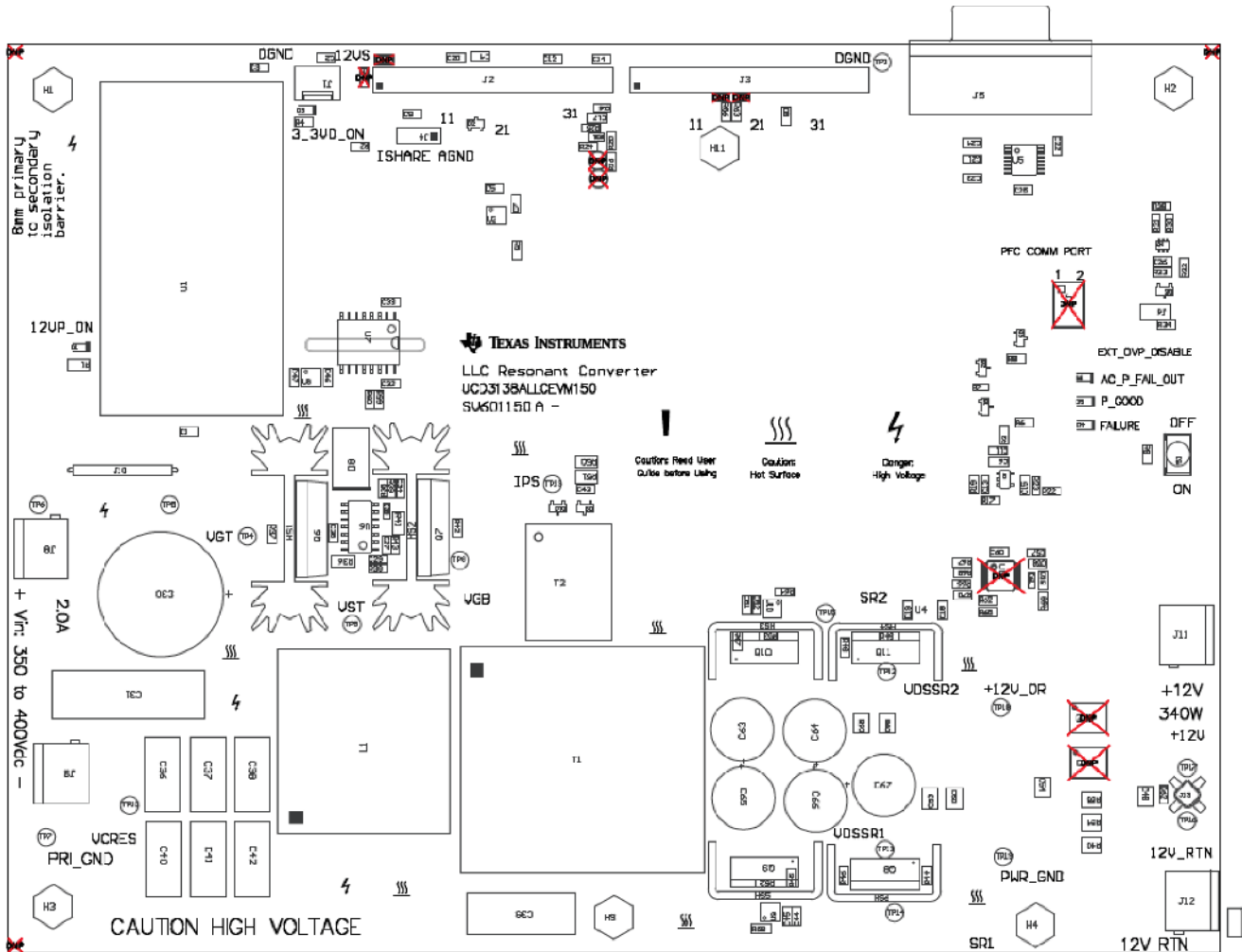

**Figure 0-26. UCD3138ALLCEVM150 Top Layer Assembly Drawing (Top View)**

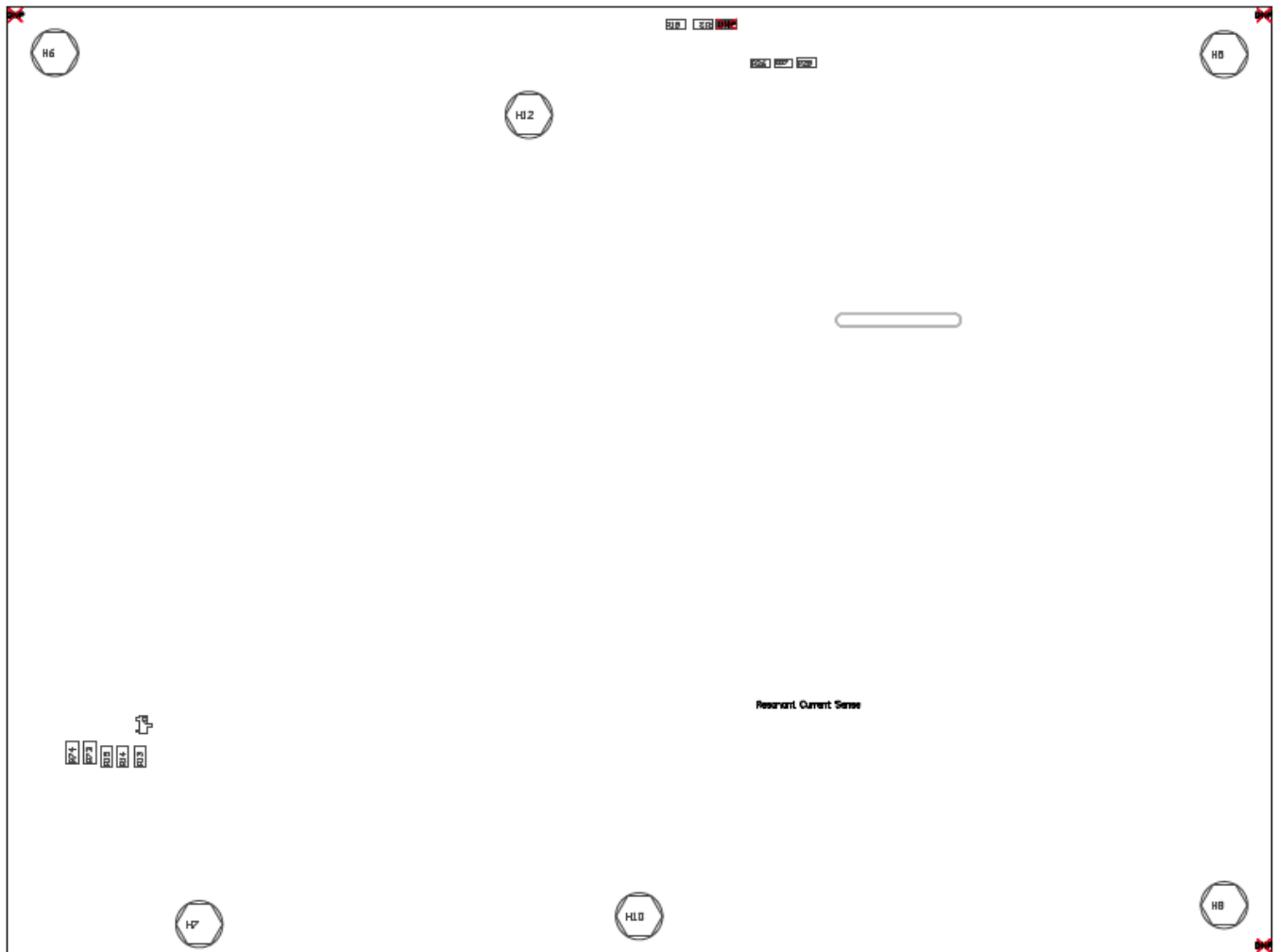

**Figure 0-27. UCD3138ALLCEVM150 Bottom Assembly Drawing (Bottom View)**

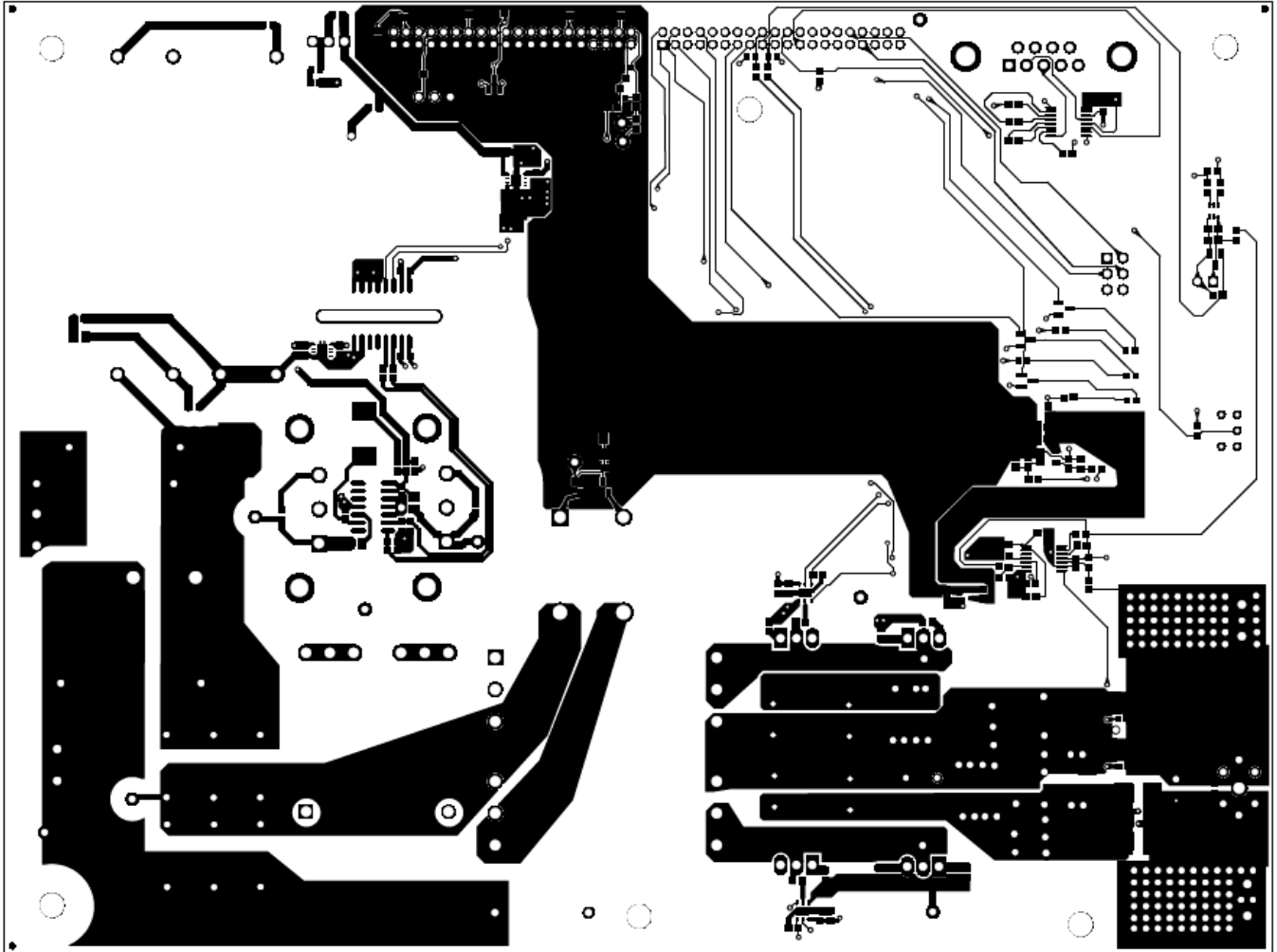
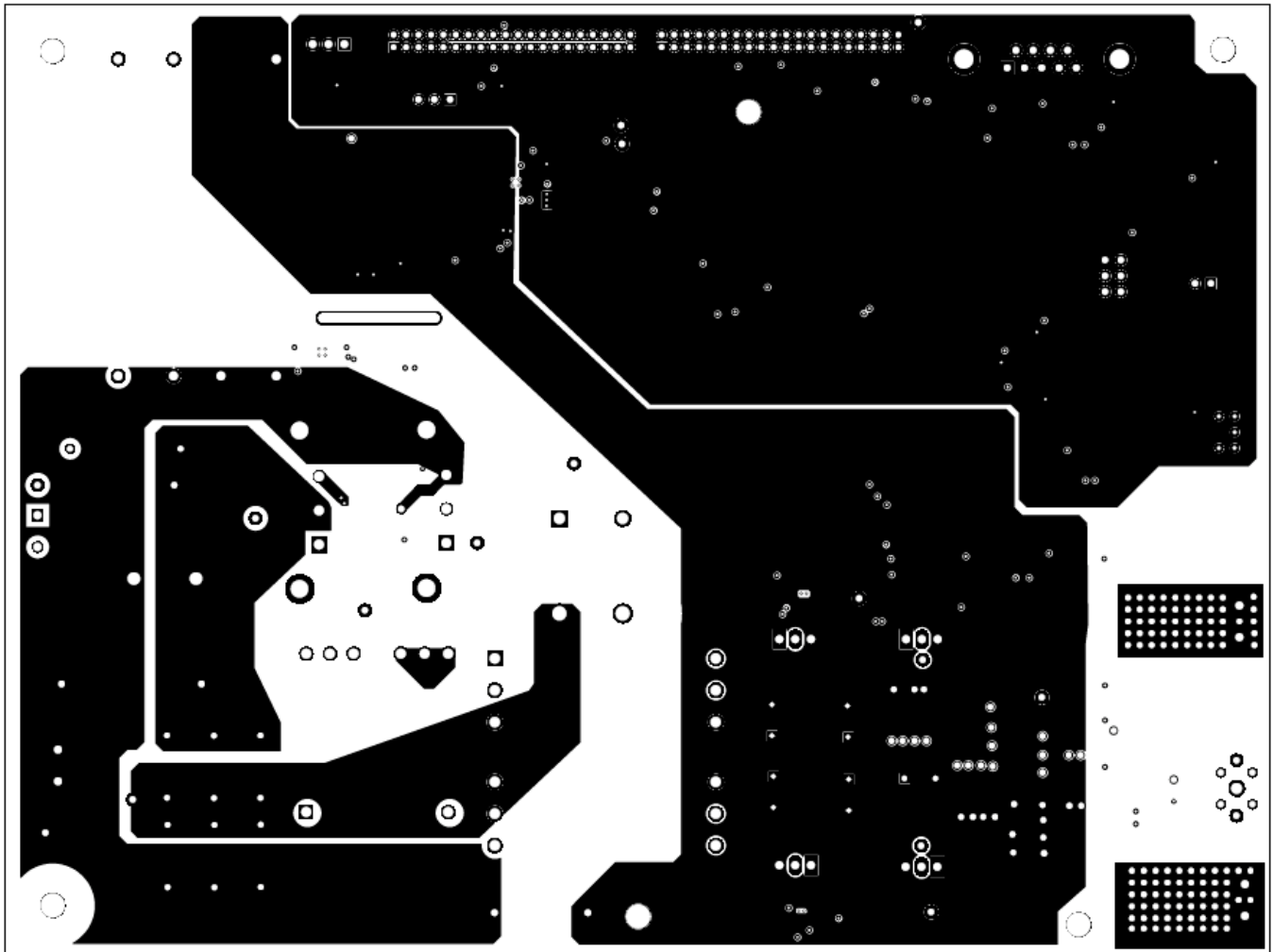

Figure 0-28. UCD3138LLCEVM150 Top Copper (Top View)



**Figure 0-29. UCD3138LLCEVM150 Internal Layer 1 (Top View)**



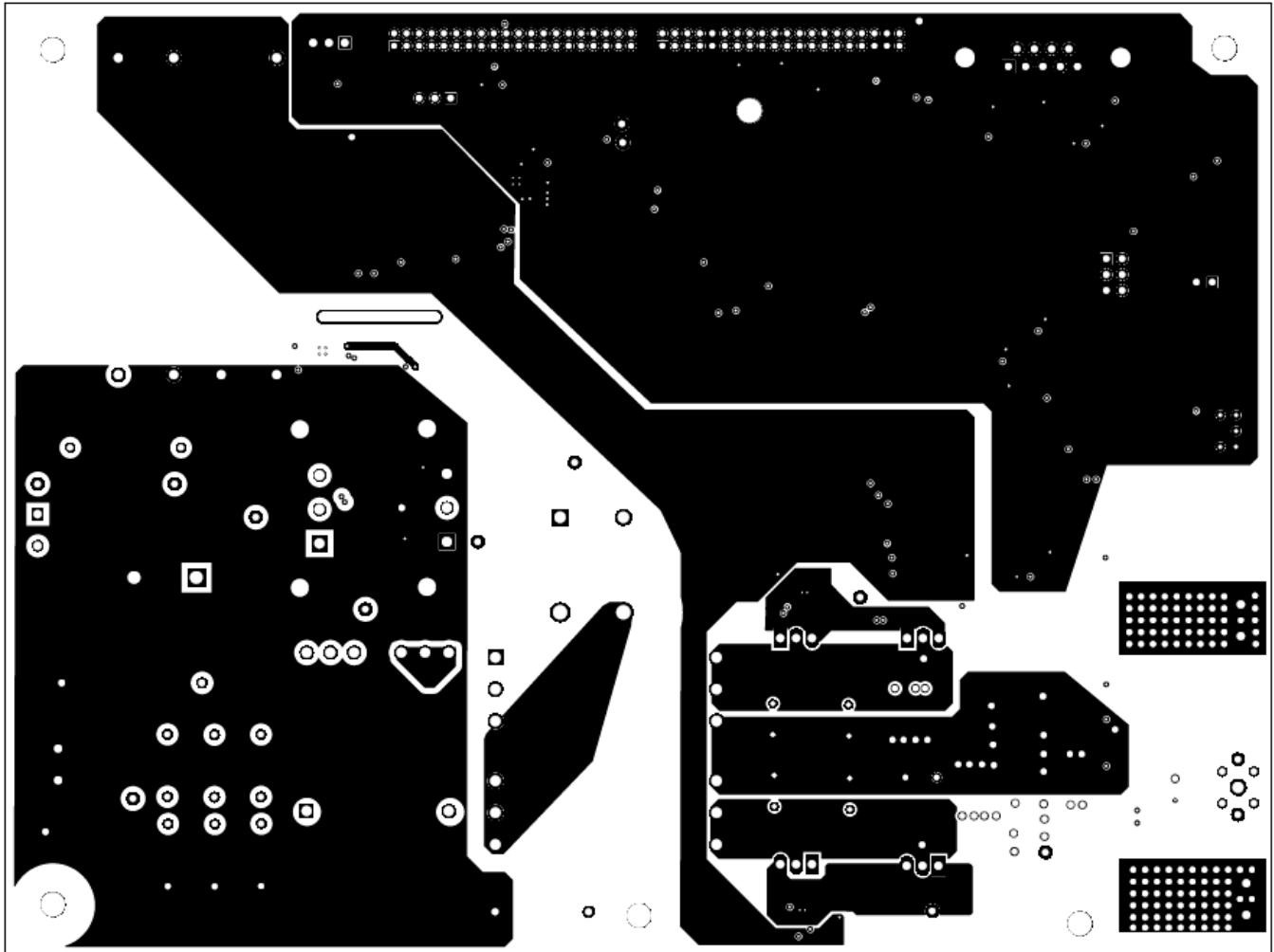

Figure 0-30. UCD3138LLCEVM150 Internal Layer 2 (Top View)

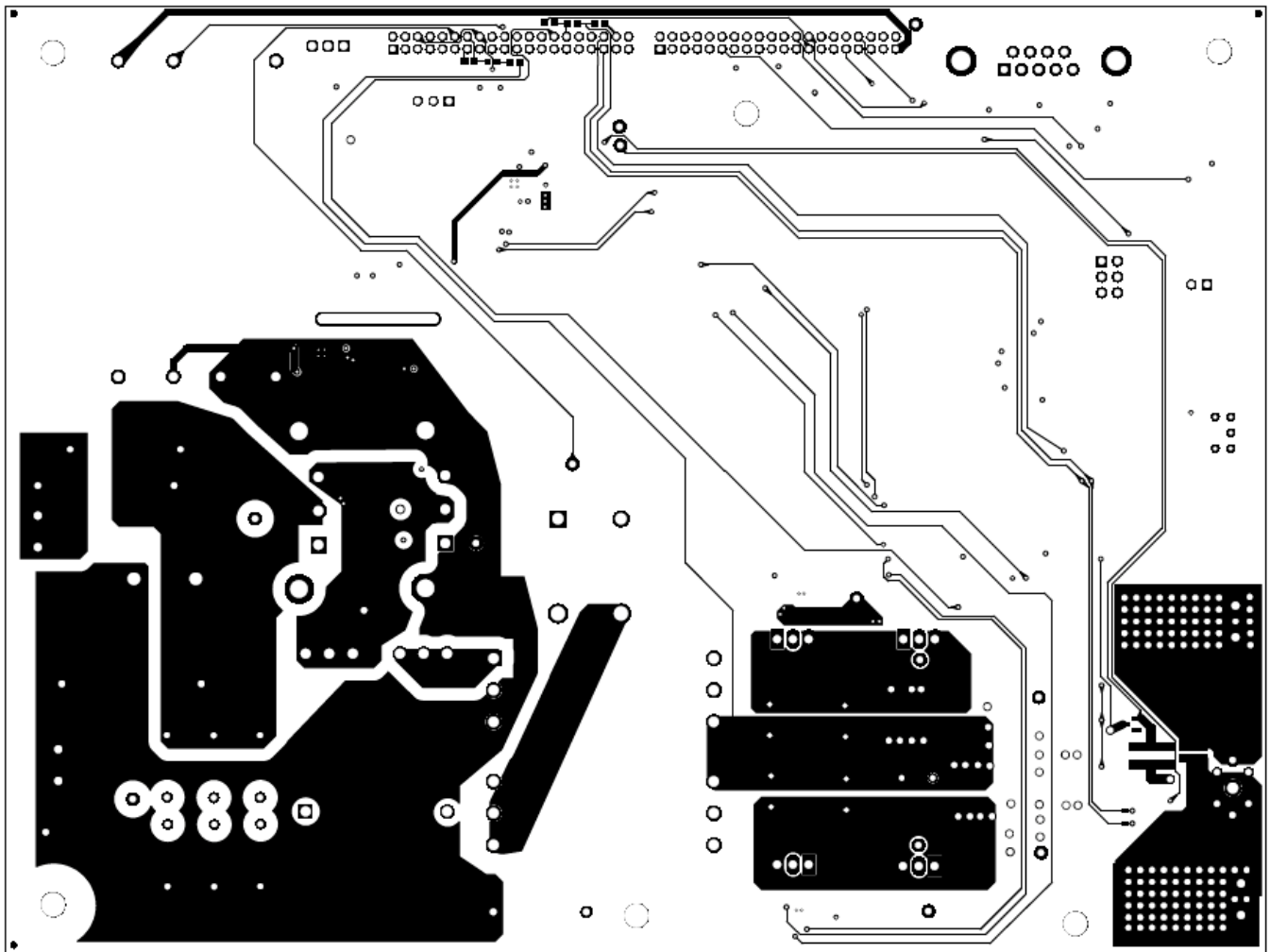

Figure 0-31. UCD3138LLCEVM150 Bottom Copper (Top View)

## 0.11 List of Materials

Component list based on [Figure 0-10](#) and [Figure 0-11](#).

**Table 0-4. UCD3138LLCEVM150 List of Materials**

REFERENCE DESIGNATOR	QTY	DESCRIPTION	PART NO.	MANUFACTURER
PCB	1	Printed Circuit Board	SV601150	Any
C1, C2, C4, C5, C6, C8, C11, C12, C21, C22, C23, C24, C25, C26, C32, C33, C35, C45, C52, C62	20	Capacitor, ceramic, 0.1 $\mu$ F, 16 V, $\pm$ 10%, X7R, 0603	C0603C104K4RACTU	Kemet
C3, C28, C34, C44, C51	5	Capacitor, ceramic, 2.2 $\mu$ F, 16 V, $\pm$ 10%, X5R, 0603	GRM188R61C225KE15D	MuRata
C7, C46	2	Capacitor, ceramic, 1 $\mu$ F, 16 V, $\pm$ 10%, X7R, 0603	C1608X7R1C105K	TDK
C9, C14, C18, C19, C60, C61	6	Capacitor, ceramic, 0.01 $\mu$ F, 16 V, $\pm$ 10%, X7R, 0603	GRM188R71C103KA01D	MuRata
C10	0	Capacitor, ceramic, 0.1 $\mu$ F, 16 V, $\pm$ 10%, X7R, 0603	C0603C104K4RACTU	Kemet
C13, C15	2	Capacitor, ceramic, 220 pF, 50 V, $\pm$ 10%, X7R, 0603	C0603C221K5RACTU	Kemet
C16, C17, C20, C57	4	Capacitor, ceramic, 2200 pF, 50 V, $\pm$ 10%, X7R, 0603	C0603C222K5RAC	Kemet
C27, C29	2	Capacitor, ceramic, 220 pF, 100 V, $\pm$ 10%, X7R, 0603	0603C221KAT2A	AVX
C30	1	Capacitor, aluminum, 47 $\mu$ F, 450 V, $\pm$ 20%, TH	LGU2W470MELY	Nichicon
C31	1	Capacitor, film, 1.5 $\mu$ F, 450 V, $\pm$ 10%, TH	ECQ-E2W155KH	Panasonic
C36, C37, C38, C40, C41, C42	6	Capacitor, film, 0.015 $\mu$ F, 630 V, $\pm$ 5%, TH	ECWF6153JL	Panasonic
C39	1	Capacitor, film, 2200 pF, 3000 V, $\pm$ 20%, TH	B81123C1222M	EPCOS Inc
C43, C58, C59	3	Capacitor, ceramic, 100 pF, 25 V, $\pm$ 10%, X7R, 0603	06033C101KAT2A	AVX
C47	1	Capacitor, ceramic, 0.1 $\mu$ F, 16 V, $\pm$ 5%, X7R, 0603	0603YC104JAT2A	AVX
C48	1	Capacitor, ceramic, 4.7 $\mu$ F, 50 V, $\pm$ 10%, X7R, 1210	GRM32ER71H475KA88L	MuRata
C49, C56	0	Capacitor, ceramic, 100 pF, 25 V, $\pm$ 10%, X7R, 0603	06033C101KAT2A	AVX
C50, C53, C54, C55, C68	5	Capacitor, ceramic, 47 $\mu$ F, 16 V, $\pm$ 20%, X5R, 1210	GRM32ER61C476ME15L	MuRata
C63, C64, C65, C66, C67	5	Capacitor, aluminum, 470 $\mu$ F, 16 V, $\pm$ 20%, 0.009 $\Omega$ , TH	PLF1C471MDO1	Nichicon
D1, D3, D5	3	LED, green, SMD	LTST-C190GKT	Lite-On
D2, D9, D10	3	Diode, Schottky, 30 V, 0.2 A, SOT-23	BAT54S-E3-08	Vishay-Semiconductor
D4, D6	2	LED, red, SMD	LTST-C190CKT	Lite-On
D7	1	Diode, P-N, 100 V, 0.2 A, SOT-23	MMD914	Fairchild Semiconductor
D8	1	Diode, ultrafast, 600 V, 3 A, SMC	MURS360T3G	ON Semiconductor
H1, H2, H3, H4, H9, H11	6	HEX standoff 6-32 nylon 1-1/2"	4824	Keystone
H5, H6, H7, H8, H10, H12	6	Standoff, hex, 0.5"L #6-32 nylon	1903C	Keystone
H13, H20	2	Large thermal pad to substitute for the smaller one in the TO-247 mounting kit	SP900S-0.009-00-104	Bergquist
H14, H15, H16, H17	4	TO-220 mounting kit	4880SG	Aavid Thermalloy
H18, H19	2	TO-247 mounting kit	4880SG	Aavid Thermalloy
H21	1	3138ACC32EVM-149	3138ACC32EVM-149	Texas Instruments
H22	1	USB to GPIO adaptor	HPA172	Used in BOM report
HS1, HS2	2	Heat sink TO-218/TO-247 W/pins 2"	513201B02500G	Aavid
HS3, HS4, HS5, HS6	4	Heat sink, TO-220	507302B00000G	Aavid
J1	1	Conn header 3 pos .100 vert tin	22-27-2031	Molex
J2, J3	2	Header, 2mm, 20 x 2, gold, TH	87758-4016	Molex
J4	1	Header, 100mil, 3 x 1, tin, TH	PEC03SAAN	Sullins Connector Solutions
J5	1	Conn DB9 female R/A solder TH	182-009-213R171	NorComp
J6	1	Header, 100 mil, 2 x 1, tin, TH	PEC02SAAN	Sullins Connector Solutions
J7	0	Header, 100 mil, 3 x 2, tin, TH	PEC03DAAN	Sullins Connector Solutions
J8, J9, J11, J12	4	Terminal block 5.08 mm verticle 2pos, TH	ED120/2DS	On-Shore Technology
J10	1	Jumper wire, 700-mil spacing, violet, pkg of 150, TH	923345-07-C	3M
J13	1	Compact probe tip circuit board test points, TH, 25 per	131-5031-00	Tektronix
L1	1	Inductor, , TH	11698	Payton
Q1, Q2, Q3, Q5	4	MOSFET, N-channel, 60 V, 0.17 A, SOT-23	2N7002-7-F	Diodes Inc.
Q4	1	Transistor, NPN/PNP Pair, 40 V, 0.6 A, SOT-363	MMDT4413-7-F	Diodes Inc.
Q6, Q7	2	MOSFET, N-channel, 650 V, 20.7 A, TO-247	SPW20N60CFD	Infineon Technologies
Q8, Q9, Q10, Q11	4	MOSFET, N-channel, 60 V, 195 A, TO-220AB	IRLB3036PBF	International Rectifier
Q12, Q13	0	MOSFET, N-channel, 25 V, 100 A, SON 5 mm x 6 mm	CSD16325Q5	Texas Instruments
R1	1	Resistor, 1.47 k $\Omega$ , 1%, 0.125 W, 0805	CRCW08051K47FKEA	Vishay-Dale
R2, R3, R44, R45, R47, R48	6	Resistor, 1.00 $\Omega$ , 1%, 0.1 W, 0603	CRCW06031R00FKEA	Vishay-Dale
R4, R6, R7, R8	4	Resistor, 301 $\Omega$ , 1%, 0.1 W, 0603	CRCW0603301RFKEA	Vishay-Dale

**Table 0-4. UCD3138LLCEVM150 List of Materials (continued)**

REFERENCE DESIGNATOR	QTY	DESCRIPTION	PART NO.	MANUFACTURER
R5, R67	2	Resistor, 10.0 Ω, 1%, 0.1 W, 0603	CRCW060310R0FKEA	Vishay-Dale
R9, R37, R42, R68	4	Resistor, 5.11 kΩ, 1%, 0.1 W, 0603	CRCW06035K11FKEA	Vishay-Dale
R10, R11	0	Resistor, 1.00 kΩ, 1%, 0.1 W, 0603	CRCW06031K00FKEA	Vishay-Dale
R12, R17, R18, R21, R22, R25, R28, R33, R46, R49	10	Resistor, 1.00 kΩ, 1%, 0.1 W, 0603	CRCW06031K00FKEA	Vishay-Dale
R13, R14, R15	3	Resistor, 549 Ω, 1%, 0.25 W, 1206	RC1206FR-07549RL	Yageo America
R16, R27, R30, R31	4	Resistor, 100 Ω, 1%, 0.1 W, 0603	CRCW0603100R0FKEA	Vishay-Dale
R19, R23	2	Resistor, 35.7 kΩ, 1%, 0.1 W, 0603	CRCW060335K7FKEA	Vishay-Dale
R20, R24, R26, R34, R38, R43, R58, R62, R64, R66, R69	11	Resistor, 10.0 kΩ, 1%, 0.1 W, 0603	CRCW060310K0FKEA	Vishay-Dale
R29, R32	2	Resistor, 20.0 kΩ, 1%, 0.1 W, 0603	CRCW060320K0FKEA	Vishay-Dale
R35	1	Resistor, 2.2 Ω, 5%, 0.1 W, 0603	CRCW06032R20JNEA	Vishay-Dale
R36, R41	2	Resistor, 10.0 Ω, 1%, 0.125 W, 0805	RC0805FR-0710RL	Yageo America
R39	1	Resistor, 5.1 Ω, 5%, 0.1 W, 0603	CRCW06035R10JNEA	Vishay-Dale
R40, R54, R55	3	Resistor, 0.003 Ω, 1%, 1 W, 1210	PMR25HZPFV3L00	Rohm
R50, R51	2	Resistor, 124 Ω, 1%, 0.125 W, 0805	CRCW0805124R0FKEA	Vishay-Dale
R52, R53	2	Resistor, 20.0 Ω, 1%, 0.1 W, 0603	CRCW060320R0FKEA	Vishay-Dale
R56, R63	2	Resistor, 0 Ω, 5%, 0.1 W, 0603	CRCW06030000Z0EA	Vishay-Dale
R57, R61	2	Resistor, 1.00 kΩ, 1%, 0.125 W, 0805	CRCW08051K00FKEA	Vishay-Dale
R59, R60	2	Resistor, 51 Ω, 5%, 0.1 W, 0603	CRCW060351R0JNEA	Vishay-Dale
R65	1	Resistor, 100 kΩ, 1%, 0.1 W, 0603	CRCW0603100K0FKEA	Vishay-Dale
R70	1	Resistor, 549 Ω, 1%, 0.1 W, 0603	CRCW0603549R0FKEA	Vishay-Dale
S1	1	Switch, toggle, SPDT 1 pos, TH	G12AP	NKK Switches
SH-J1	1	Shunt, 100 mil, flash gold black	SPC02SYAN	Sullins Connector Solutions
T1	1	Transformer, PQ35/35, TH	11697	Payton
T2	1	Transformer, current sense, 80 mH, TH	CS4200V-01L	Coilcraft
TP1, TP4, TP5, TP6, TP7, TP8, TP9, TP10, TP11, TP12, TP13, TP14, TP15, TP16, TP17, TP18, TP19	17	Test point, miniature, white, TH	5002	Keystone
TP2, TP3	0	Test point, miniature, white, TH	5002	Keystone
U1	1	UCC28600EVM, 400 V, 12 V	PWR050	Texas Instruments
U2	1	Single Output LDO, 80 mA, Fixed 3.3 V Output, 2.5 to 24 V Input, with Low IQ, 8-pin SON (DRB), -40°C to 125°C, Green (RoHS & no Sb/Br)	TPS715A33DRBR	Texas Instruments
U3	1	Precision, Low Noise, Low IQ Operational Amplifier, 2.2 V to 5.5 V, -40°C to 125°C, 5-pin SOT23 (DBV0005A), Green (RoHS & no Sb/Br)	OPA376AIDBVR	Texas Instruments
U4	1	2.4-V, 10-μA Temperature Sensor, 5-pin SC-70 Micro SMD, Pb-Free	LM20BIM7/NOPB	Texas Instruments
U5	1	3-V to 5.5-V Single-Channel RS-232 Compatible Line Driver/Receiver, -40°C to 85°C, 16-Pin TSSOP (PW), Green (RoHS & no Sb/Br)	SN65C3221PW	Texas Instruments
U6	1	High-Speed, 4-A, 600-V High-side Low-side Gate Driver Device, D0014A	UCC27714D	Texas Instruments
U7	1	25-Mbps Automotive Catalog Quad, 4/0, Digital Isolator, Selectable Failsafe, 3.3 V / 5 V, -40°C to 125°C, 16-pin SOIC (DW), Green (RoHS & no Sb/Br)	ISO7240CFQDWRQ1	Texas Instruments
U8	1	High Input Voltage, Micropower SON Packaged, 80-mA, LDO Linear Regulators, DRB0008A	TPS715A33DRB	Texas Instruments
U9, U10	2	UCD7138 Low-Side Power MOSFET Driver with Body Diode Conduction Sensing	UCD7138DRS	Texas Instruments
U11	0	Full Featured N+1 and ORing Power Rail Controller	TPS2411PWR	Texas Instruments

**NOTE:** PWR050 is a bias board and its design documents can be found from [www.ti.com](http://www.ti.com).

## 0.12 References

1. UCD3138A Data Manual, [SLUSC66](#)
2. UCD3138ACCEVM149 Evaluation Module and User's Guide, Programmable Digital Power Controller Control Card Evaluation Module, [SLUUB82](#)
3. Fusion Digital Power Designer GUI for Isolated Power Applications User Guide (for UCD3138, UCD3138064, UCD3138A Applications), [SLUA676](#)
4. [Designing an LLC Resonant Half-Bridge Power Converter](#), SEM1900
5. [Feedback Loop Design of an LLC Resonant Power Converter](#), SLUA582A
6. [UCD3138 Digital Power Peripherals Programmer's Manual](#), SLUU995
7. [UCD3138 Monitoring and Communications Programmer's Manual](#), SLUU996
8. [UCD3138 ARM and Digital System Programmer's Manual](#), SLUU994

## Revision History

### Changes from Original (March 2015) to A Revision

Page

• Deleted USB-to-GPIO from EVM package.....	3
• Deleted USB-to-GPIO from EVM package. ....	15

NOTE: Page numbers for previous revisions may differ from page numbers in the current version.

## STANDARD TERMS AND CONDITIONS FOR EVALUATION MODULES

1. *Delivery:* TI delivers TI evaluation boards, kits, or modules, including any accompanying demonstration software, components, or documentation (collectively, an "EVM" or "EVMs") to the User ("User") in accordance with the terms and conditions set forth herein. Acceptance of the EVM is expressly subject to the following terms and conditions.
  - 1.1 EVMs are intended solely for product or software developers for use in a research and development setting to facilitate feasibility evaluation, experimentation, or scientific analysis of TI semiconductors products. EVMs have no direct function and are not finished products. EVMs shall not be directly or indirectly assembled as a part or subassembly in any finished product. For clarification, any software or software tools provided with the EVM ("Software") shall not be subject to the terms and conditions set forth herein but rather shall be subject to the applicable terms and conditions that accompany such Software
  - 1.2 EVMs are not intended for consumer or household use. EVMs may not be sold, sublicensed, leased, rented, loaned, assigned, or otherwise distributed for commercial purposes by Users, in whole or in part, or used in any finished product or production system.
2. *Limited Warranty and Related Remedies/Disclaimers:*
  - 2.1 These terms and conditions do not apply to Software. The warranty, if any, for Software is covered in the applicable Software License Agreement.
  - 2.2 TI warrants that the TI EVM will conform to TI's published specifications for ninety (90) days after the date TI delivers such EVM to User. Notwithstanding the foregoing, TI shall not be liable for any defects that are caused by neglect, misuse or mistreatment by an entity other than TI, including improper installation or testing, or for any EVMs that have been altered or modified in any way by an entity other than TI. Moreover, TI shall not be liable for any defects that result from User's design, specifications or instructions for such EVMs. Testing and other quality control techniques are used to the extent TI deems necessary or as mandated by government requirements. TI does not test all parameters of each EVM.
  - 2.3 If any EVM fails to conform to the warranty set forth above, TI's sole liability shall be at its option to repair or replace such EVM, or credit User's account for such EVM. TI's liability under this warranty shall be limited to EVMs that are returned during the warranty period to the address designated by TI and that are determined by TI not to conform to such warranty. If TI elects to repair or replace such EVM, TI shall have a reasonable time to repair such EVM or provide replacements. Repaired EVMs shall be warranted for the remainder of the original warranty period. Replaced EVMs shall be warranted for a new full ninety (90) day warranty period.
3. *Regulatory Notices:*
  - 3.1 *United States*
    - 3.1.1 *Notice applicable to EVMs not FCC-Approved:*

This kit is designed to allow product developers to evaluate electronic components, circuitry, or software associated with the kit to determine whether to incorporate such items in a finished product and software developers to write software applications for use with the end product. This kit is not a finished product and when assembled may not be resold or otherwise marketed unless all required FCC equipment authorizations are first obtained. Operation is subject to the condition that this product not cause harmful interference to licensed radio stations and that this product accept harmful interference. Unless the assembled kit is designed to operate under part 15, part 18 or part 95 of this chapter, the operator of the kit must operate under the authority of an FCC license holder or must secure an experimental authorization under part 5 of this chapter.
    - 3.1.2 *For EVMs annotated as FCC – FEDERAL COMMUNICATIONS COMMISSION Part 15 Compliant:*

### CAUTION

This device complies with part 15 of the FCC Rules. Operation is subject to the following two conditions: (1) This device may not cause harmful interference, and (2) this device must accept any interference received, including interference that may cause undesired operation.

Changes or modifications not expressly approved by the party responsible for compliance could void the user's authority to operate the equipment.

### FCC Interference Statement for Class A EVM devices

*NOTE: This equipment has been tested and found to comply with the limits for a Class A digital device, pursuant to part 15 of the FCC Rules. These limits are designed to provide reasonable protection against harmful interference when the equipment is operated in a commercial environment. This equipment generates, uses, and can radiate radio frequency energy and, if not installed and used in accordance with the instruction manual, may cause harmful interference to radio communications. Operation of this equipment in a residential area is likely to cause harmful interference in which case the user will be required to correct the interference at his own expense.*

## FCC Interference Statement for Class B EVM devices

*NOTE: This equipment has been tested and found to comply with the limits for a Class B digital device, pursuant to part 15 of the FCC Rules. These limits are designed to provide reasonable protection against harmful interference in a residential installation. This equipment generates, uses and can radiate radio frequency energy and, if not installed and used in accordance with the instructions, may cause harmful interference to radio communications. However, there is no guarantee that interference will not occur in a particular installation. If this equipment does cause harmful interference to radio or television reception, which can be determined by turning the equipment off and on, the user is encouraged to try to correct the interference by one or more of the following measures:*

- Reorient or relocate the receiving antenna.
- Increase the separation between the equipment and receiver.
- Connect the equipment into an outlet on a circuit different from that to which the receiver is connected.
- Consult the dealer or an experienced radio/TV technician for help.

### 3.2 Canada

3.2.1 For EVMs issued with an Industry Canada Certificate of Conformance to RSS-210

#### Concerning EVMs Including Radio Transmitters:

This device complies with Industry Canada license-exempt RSS standard(s). Operation is subject to the following two conditions: (1) this device may not cause interference, and (2) this device must accept any interference, including interference that may cause undesired operation of the device.

#### Concernant les EVMs avec appareils radio:

Le présent appareil est conforme aux CNR d'Industrie Canada applicables aux appareils radio exempts de licence. L'exploitation est autorisée aux deux conditions suivantes: (1) l'appareil ne doit pas produire de brouillage, et (2) l'utilisateur de l'appareil doit accepter tout brouillage radioélectrique subi, même si le brouillage est susceptible d'en compromettre le fonctionnement.

#### Concerning EVMs Including Detachable Antennas:

Under Industry Canada regulations, this radio transmitter may only operate using an antenna of a type and maximum (or lesser) gain approved for the transmitter by Industry Canada. To reduce potential radio interference to other users, the antenna type and its gain should be so chosen that the equivalent isotropically radiated power (e.i.r.p.) is not more than that necessary for successful communication. This radio transmitter has been approved by Industry Canada to operate with the antenna types listed in the user guide with the maximum permissible gain and required antenna impedance for each antenna type indicated. Antenna types not included in this list, having a gain greater than the maximum gain indicated for that type, are strictly prohibited for use with this device.

#### Concernant les EVMs avec antennes détachables

Conformément à la réglementation d'Industrie Canada, le présent émetteur radio peut fonctionner avec une antenne d'un type et d'un gain maximal (ou inférieur) approuvé pour l'émetteur par Industrie Canada. Dans le but de réduire les risques de brouillage radioélectrique à l'intention des autres utilisateurs, il faut choisir le type d'antenne et son gain de sorte que la puissance isotrope rayonnée équivalente (p.i.r.e.) ne dépasse pas l'intensité nécessaire à l'établissement d'une communication satisfaisante. Le présent émetteur radio a été approuvé par Industrie Canada pour fonctionner avec les types d'antenne énumérés dans le manuel d'usage et ayant un gain admissible maximal et l'impédance requise pour chaque type d'antenne. Les types d'antenne non inclus dans cette liste, ou dont le gain est supérieur au gain maximal indiqué, sont strictement interdits pour l'exploitation de l'émetteur.

### 3.3 Japan

3.3.1 *Notice for EVMs delivered in Japan:* Please see [http://www.tij.co.jp/lstds/ti\\_ja/general/eStore/notice\\_01.page](http://www.tij.co.jp/lstds/ti_ja/general/eStore/notice_01.page) 日本国内に輸入される評価用キット、ボードについては、次のところをご覧ください。  
[http://www.tij.co.jp/lstds/ti\\_ja/general/eStore/notice\\_01.page](http://www.tij.co.jp/lstds/ti_ja/general/eStore/notice_01.page)

3.3.2 *Notice for Users of EVMs Considered "Radio Frequency Products" in Japan:* EVMs entering Japan may not be certified by TI as conforming to Technical Regulations of Radio Law of Japan.

If User uses EVMs in Japan, not certified to Technical Regulations of Radio Law of Japan, User is required by Radio Law of Japan to follow the instructions below with respect to EVMs:

1. Use EVMs in a shielded room or any other test facility as defined in the notification #173 issued by Ministry of Internal Affairs and Communications on March 28, 2006, based on Sub-section 1.1 of Article 6 of the Ministry's Rule for Enforcement of Radio Law of Japan,
2. Use EVMs only after User obtains the license of Test Radio Station as provided in Radio Law of Japan with respect to EVMs, or
3. Use of EVMs only after User obtains the Technical Regulations Conformity Certification as provided in Radio Law of Japan with respect to EVMs. Also, do not transfer EVMs, unless User gives the same notice above to the transferee. Please note that if User does not follow the instructions above, User will be subject to penalties of Radio Law of Japan.

【無線電波を送信する製品の開発キットをお使いになる際の注意事項】 開発キットの中には技術基準適合証明を受けていないものがあります。技術適合証明を受けていないものご使用に際しては、電波法遵守のため、以下のいずれかの措置を取っていただく必要がありますのでご注意ください。

1. 電波法施行規則第6条第1項第1号に基づく平成18年3月28日総務省告示第173号で定められた電波暗室等の試験設備でご使用いただく。
2. 実験局の免許を取得後ご使用いただく。
3. 技術基準適合証明を取得後ご使用いただく。

なお、本製品は、上記の「ご使用にあたっての注意」を譲渡先、移転先に通知しない限り、譲渡、移転できないものとします。

上記を遵守頂けない場合は、電波法の罰則が適用される可能性があることをご留意ください。日本テキサス・インスツルメンツ株式会社  
東京都新宿区西新宿 6 丁目 2 4 番 1 号  
西新宿三井ビル

3.3.3 *Notice for EVMs for Power Line Communication:* Please see [http://www.tij.co.jp/llds/ti\\_ja/general/eStore/notice\\_02.page](http://www.tij.co.jp/llds/ti_ja/general/eStore/notice_02.page)  
電力線搬送波通信についての開発キットをお使いになる際の注意事項については、次のところをご覧ください。 [http://www.tij.co.jp/llds/ti\\_ja/general/eStore/notice\\_02.page](http://www.tij.co.jp/llds/ti_ja/general/eStore/notice_02.page)

#### 4 *EVM Use Restrictions and Warnings:*

4.1 EVMS ARE NOT FOR USE IN FUNCTIONAL SAFETY AND/OR SAFETY CRITICAL EVALUATIONS, INCLUDING BUT NOT LIMITED TO EVALUATIONS OF LIFE SUPPORT APPLICATIONS.

4.2 User must read and apply the user guide and other available documentation provided by TI regarding the EVM prior to handling or using the EVM, including without limitation any warning or restriction notices. The notices contain important safety information related to, for example, temperatures and voltages.

#### 4.3 *Safety-Related Warnings and Restrictions:*

4.3.1 User shall operate the EVM within TI's recommended specifications and environmental considerations stated in the user guide, other available documentation provided by TI, and any other applicable requirements and employ reasonable and customary safeguards. Exceeding the specified performance ratings and specifications (including but not limited to input and output voltage, current, power, and environmental ranges) for the EVM may cause personal injury or death, or property damage. If there are questions concerning performance ratings and specifications, User should contact a TI field representative prior to connecting interface electronics including input power and intended loads. Any loads applied outside of the specified output range may also result in unintended and/or inaccurate operation and/or possible permanent damage to the EVM and/or interface electronics. Please consult the EVM user guide prior to connecting any load to the EVM output. If there is uncertainty as to the load specification, please contact a TI field representative. During normal operation, even with the inputs and outputs kept within the specified allowable ranges, some circuit components may have elevated case temperatures. These components include but are not limited to linear regulators, switching transistors, pass transistors, current sense resistors, and heat sinks, which can be identified using the information in the associated documentation. When working with the EVM, please be aware that the EVM may become very warm.

4.3.2 EVMs are intended solely for use by technically qualified, professional electronics experts who are familiar with the dangers and application risks associated with handling electrical mechanical components, systems, and subsystems. User assumes all responsibility and liability for proper and safe handling and use of the EVM by User or its employees, affiliates, contractors or designees. User assumes all responsibility and liability to ensure that any interfaces (electronic and/or mechanical) between the EVM and any human body are designed with suitable isolation and means to safely limit accessible leakage currents to minimize the risk of electrical shock hazard. User assumes all responsibility and liability for any improper or unsafe handling or use of the EVM by User or its employees, affiliates, contractors or designees.

4.4 User assumes all responsibility and liability to determine whether the EVM is subject to any applicable international, federal, state, or local laws and regulations related to User's handling and use of the EVM and, if applicable, User assumes all responsibility and liability for compliance in all respects with such laws and regulations. User assumes all responsibility and liability for proper disposal and recycling of the EVM consistent with all applicable international, federal, state, and local requirements.

5. *Accuracy of Information:* To the extent TI provides information on the availability and function of EVMs, TI attempts to be as accurate as possible. However, TI does not warrant the accuracy of EVM descriptions, EVM availability or other information on its websites as accurate, complete, reliable, current, or error-free.



6. *Disclaimers:*
- 6.1 EXCEPT AS SET FORTH ABOVE, EVMS AND ANY WRITTEN DESIGN MATERIALS PROVIDED WITH THE EVM (AND THE DESIGN OF THE EVM ITSELF) ARE PROVIDED "AS IS" AND "WITH ALL FAULTS." TI DISCLAIMS ALL OTHER WARRANTIES, EXPRESS OR IMPLIED, REGARDING SUCH ITEMS, INCLUDING BUT NOT LIMITED TO ANY IMPLIED WARRANTIES OF MERCHANTABILITY OR FITNESS FOR A PARTICULAR PURPOSE OR NON-INFRINGEMENT OF ANY THIRD PARTY PATENTS, COPYRIGHTS, TRADE SECRETS OR OTHER INTELLECTUAL PROPERTY RIGHTS.
- 6.2 EXCEPT FOR THE LIMITED RIGHT TO USE THE EVM SET FORTH HEREIN, NOTHING IN THESE TERMS AND CONDITIONS SHALL BE CONSTRUED AS GRANTING OR CONFERRING ANY RIGHTS BY LICENSE, PATENT, OR ANY OTHER INDUSTRIAL OR INTELLECTUAL PROPERTY RIGHT OF TI, ITS SUPPLIERS/LICENSORS OR ANY OTHER THIRD PARTY, TO USE THE EVM IN ANY FINISHED END-USER OR READY-TO-USE FINAL PRODUCT, OR FOR ANY INVENTION, DISCOVERY OR IMPROVEMENT MADE, CONCEIVED OR ACQUIRED PRIOR TO OR AFTER DELIVERY OF THE EVM.
7. *USER'S INDEMNITY OBLIGATIONS AND REPRESENTATIONS.* USER WILL DEFEND, INDEMNIFY AND HOLD TI, ITS LICENSORS AND THEIR REPRESENTATIVES HARMLESS FROM AND AGAINST ANY AND ALL CLAIMS, DAMAGES, LOSSES, EXPENSES, COSTS AND LIABILITIES (COLLECTIVELY, "CLAIMS") ARISING OUT OF OR IN CONNECTION WITH ANY HANDLING OR USE OF THE EVM THAT IS NOT IN ACCORDANCE WITH THESE TERMS AND CONDITIONS. THIS OBLIGATION SHALL APPLY WHETHER CLAIMS ARISE UNDER STATUTE, REGULATION, OR THE LAW OF TORT, CONTRACT OR ANY OTHER LEGAL THEORY, AND EVEN IF THE EVM FAILS TO PERFORM AS DESCRIBED OR EXPECTED.
8. *Limitations on Damages and Liability:*
- 8.1 *General Limitations.* IN NO EVENT SHALL TI BE LIABLE FOR ANY SPECIAL, COLLATERAL, INDIRECT, PUNITIVE, INCIDENTAL, CONSEQUENTIAL, OR EXEMPLARY DAMAGES IN CONNECTION WITH OR ARISING OUT OF THESE TERMS AND CONDITIONS OR THE USE OF THE EVMS PROVIDED HEREUNDER, REGARDLESS OF WHETHER TI HAS BEEN ADVISED OF THE POSSIBILITY OF SUCH DAMAGES. EXCLUDED DAMAGES INCLUDE, BUT ARE NOT LIMITED TO, COST OF REMOVAL OR REINSTALLATION, ANCILLARY COSTS TO THE PROCUREMENT OF SUBSTITUTE GOODS OR SERVICES, RETESTING, OUTSIDE COMPUTER TIME, LABOR COSTS, LOSS OF GOODWILL, LOSS OF PROFITS, LOSS OF SAVINGS, LOSS OF USE, LOSS OF DATA, OR BUSINESS INTERRUPTION. NO CLAIM, SUIT OR ACTION SHALL BE BROUGHT AGAINST TI MORE THAN ONE YEAR AFTER THE RELATED CAUSE OF ACTION HAS OCCURRED.
- 8.2 *Specific Limitations.* IN NO EVENT SHALL TI'S AGGREGATE LIABILITY FROM ANY WARRANTY OR OTHER OBLIGATION ARISING OUT OF OR IN CONNECTION WITH THESE TERMS AND CONDITIONS, OR ANY USE OF ANY TI EVM PROVIDED HEREUNDER, EXCEED THE TOTAL AMOUNT PAID TO TI FOR THE PARTICULAR UNITS SOLD UNDER THESE TERMS AND CONDITIONS WITH RESPECT TO WHICH LOSSES OR DAMAGES ARE CLAIMED. THE EXISTENCE OF MORE THAN ONE CLAIM AGAINST THE PARTICULAR UNITS SOLD TO USER UNDER THESE TERMS AND CONDITIONS SHALL NOT ENLARGE OR EXTEND THIS LIMIT.
9. *Return Policy.* Except as otherwise provided, TI does not offer any refunds, returns, or exchanges. Furthermore, no return of EVM(s) will be accepted if the package has been opened and no return of the EVM(s) will be accepted if they are damaged or otherwise not in a resalable condition. If User feels it has been incorrectly charged for the EVM(s) it ordered or that delivery violates the applicable order, User should contact TI. All refunds will be made in full within thirty (30) working days from the return of the components(s), excluding any postage or packaging costs.
10. *Governing Law:* These terms and conditions shall be governed by and interpreted in accordance with the laws of the State of Texas, without reference to conflict-of-laws principles. User agrees that non-exclusive jurisdiction for any dispute arising out of or relating to these terms and conditions lies within courts located in the State of Texas and consents to venue in Dallas County, Texas. Notwithstanding the foregoing, any judgment may be enforced in any United States or foreign court, and TI may seek injunctive relief in any United States or foreign court.

Mailing Address: Texas Instruments, Post Office Box 655303, Dallas, Texas 75265  
Copyright © 2016, Texas Instruments Incorporated

## STANDARD TERMS AND CONDITIONS FOR EVALUATION MODULES

1. *Delivery:* TI delivers TI evaluation boards, kits, or modules, including any accompanying demonstration software, components, or documentation (collectively, an "EVM" or "EVMs") to the User ("User") in accordance with the terms and conditions set forth herein. Acceptance of the EVM is expressly subject to the following terms and conditions.
  - 1.1 EVMs are intended solely for product or software developers for use in a research and development setting to facilitate feasibility evaluation, experimentation, or scientific analysis of TI semiconductors products. EVMs have no direct function and are not finished products. EVMs shall not be directly or indirectly assembled as a part or subassembly in any finished product. For clarification, any software or software tools provided with the EVM ("Software") shall not be subject to the terms and conditions set forth herein but rather shall be subject to the applicable terms and conditions that accompany such Software
  - 1.2 EVMs are not intended for consumer or household use. EVMs may not be sold, sublicensed, leased, rented, loaned, assigned, or otherwise distributed for commercial purposes by Users, in whole or in part, or used in any finished product or production system.
2. *Limited Warranty and Related Remedies/Disclaimers:*
  - 2.1 These terms and conditions do not apply to Software. The warranty, if any, for Software is covered in the applicable Software License Agreement.
  - 2.2 TI warrants that the TI EVM will conform to TI's published specifications for ninety (90) days after the date TI delivers such EVM to User. Notwithstanding the foregoing, TI shall not be liable for any defects that are caused by neglect, misuse or mistreatment by an entity other than TI, including improper installation or testing, or for any EVMs that have been altered or modified in any way by an entity other than TI. Moreover, TI shall not be liable for any defects that result from User's design, specifications or instructions for such EVMs. Testing and other quality control techniques are used to the extent TI deems necessary or as mandated by government requirements. TI does not test all parameters of each EVM.
  - 2.3 If any EVM fails to conform to the warranty set forth above, TI's sole liability shall be at its option to repair or replace such EVM, or credit User's account for such EVM. TI's liability under this warranty shall be limited to EVMs that are returned during the warranty period to the address designated by TI and that are determined by TI not to conform to such warranty. If TI elects to repair or replace such EVM, TI shall have a reasonable time to repair such EVM or provide replacements. Repaired EVMs shall be warranted for the remainder of the original warranty period. Replaced EVMs shall be warranted for a new full ninety (90) day warranty period.
3. *Regulatory Notices:*
  - 3.1 *United States*
    - 3.1.1 *Notice applicable to EVMs not FCC-Approved:*

This kit is designed to allow product developers to evaluate electronic components, circuitry, or software associated with the kit to determine whether to incorporate such items in a finished product and software developers to write software applications for use with the end product. This kit is not a finished product and when assembled may not be resold or otherwise marketed unless all required FCC equipment authorizations are first obtained. Operation is subject to the condition that this product not cause harmful interference to licensed radio stations and that this product accept harmful interference. Unless the assembled kit is designed to operate under part 15, part 18 or part 95 of this chapter, the operator of the kit must operate under the authority of an FCC license holder or must secure an experimental authorization under part 5 of this chapter.
    - 3.1.2 *For EVMs annotated as FCC – FEDERAL COMMUNICATIONS COMMISSION Part 15 Compliant:*

### CAUTION

This device complies with part 15 of the FCC Rules. Operation is subject to the following two conditions: (1) This device may not cause harmful interference, and (2) this device must accept any interference received, including interference that may cause undesired operation.

Changes or modifications not expressly approved by the party responsible for compliance could void the user's authority to operate the equipment.

### FCC Interference Statement for Class A EVM devices

*NOTE: This equipment has been tested and found to comply with the limits for a Class A digital device, pursuant to part 15 of the FCC Rules. These limits are designed to provide reasonable protection against harmful interference when the equipment is operated in a commercial environment. This equipment generates, uses, and can radiate radio frequency energy and, if not installed and used in accordance with the instruction manual, may cause harmful interference to radio communications. Operation of this equipment in a residential area is likely to cause harmful interference in which case the user will be required to correct the interference at his own expense.*

## FCC Interference Statement for Class B EVM devices

*NOTE: This equipment has been tested and found to comply with the limits for a Class B digital device, pursuant to part 15 of the FCC Rules. These limits are designed to provide reasonable protection against harmful interference in a residential installation. This equipment generates, uses and can radiate radio frequency energy and, if not installed and used in accordance with the instructions, may cause harmful interference to radio communications. However, there is no guarantee that interference will not occur in a particular installation. If this equipment does cause harmful interference to radio or television reception, which can be determined by turning the equipment off and on, the user is encouraged to try to correct the interference by one or more of the following measures:*

- Reorient or relocate the receiving antenna.
- Increase the separation between the equipment and receiver.
- Connect the equipment into an outlet on a circuit different from that to which the receiver is connected.
- Consult the dealer or an experienced radio/TV technician for help.

### 3.2 Canada

3.2.1 For EVMs issued with an Industry Canada Certificate of Conformance to RSS-210

#### Concerning EVMs Including Radio Transmitters:

This device complies with Industry Canada license-exempt RSS standard(s). Operation is subject to the following two conditions: (1) this device may not cause interference, and (2) this device must accept any interference, including interference that may cause undesired operation of the device.

#### Concernant les EVMs avec appareils radio:

Le présent appareil est conforme aux CNR d'Industrie Canada applicables aux appareils radio exempts de licence. L'exploitation est autorisée aux deux conditions suivantes: (1) l'appareil ne doit pas produire de brouillage, et (2) l'utilisateur de l'appareil doit accepter tout brouillage radioélectrique subi, même si le brouillage est susceptible d'en compromettre le fonctionnement.

#### Concerning EVMs Including Detachable Antennas:

Under Industry Canada regulations, this radio transmitter may only operate using an antenna of a type and maximum (or lesser) gain approved for the transmitter by Industry Canada. To reduce potential radio interference to other users, the antenna type and its gain should be so chosen that the equivalent isotropically radiated power (e.i.r.p.) is not more than that necessary for successful communication. This radio transmitter has been approved by Industry Canada to operate with the antenna types listed in the user guide with the maximum permissible gain and required antenna impedance for each antenna type indicated. Antenna types not included in this list, having a gain greater than the maximum gain indicated for that type, are strictly prohibited for use with this device.

#### Concernant les EVMs avec antennes détachables

Conformément à la réglementation d'Industrie Canada, le présent émetteur radio peut fonctionner avec une antenne d'un type et d'un gain maximal (ou inférieur) approuvé pour l'émetteur par Industrie Canada. Dans le but de réduire les risques de brouillage radioélectrique à l'intention des autres utilisateurs, il faut choisir le type d'antenne et son gain de sorte que la puissance isotrope rayonnée équivalente (p.i.r.e.) ne dépasse pas l'intensité nécessaire à l'établissement d'une communication satisfaisante. Le présent émetteur radio a été approuvé par Industrie Canada pour fonctionner avec les types d'antenne énumérés dans le manuel d'usage et ayant un gain admissible maximal et l'impédance requise pour chaque type d'antenne. Les types d'antenne non inclus dans cette liste, ou dont le gain est supérieur au gain maximal indiqué, sont strictement interdits pour l'exploitation de l'émetteur.

### 3.3 Japan

3.3.1 *Notice for EVMs delivered in Japan:* Please see [http://www.tij.co.jp/lstds/ti\\_ja/general/eStore/notice\\_01.page](http://www.tij.co.jp/lstds/ti_ja/general/eStore/notice_01.page) 日本国内に輸入される評価用キット、ボードについては、次のところをご覧ください。  
[http://www.tij.co.jp/lstds/ti\\_ja/general/eStore/notice\\_01.page](http://www.tij.co.jp/lstds/ti_ja/general/eStore/notice_01.page)

3.3.2 *Notice for Users of EVMs Considered "Radio Frequency Products" in Japan:* EVMs entering Japan may not be certified by TI as conforming to Technical Regulations of Radio Law of Japan.

If User uses EVMs in Japan, not certified to Technical Regulations of Radio Law of Japan, User is required by Radio Law of Japan to follow the instructions below with respect to EVMs:

1. Use EVMs in a shielded room or any other test facility as defined in the notification #173 issued by Ministry of Internal Affairs and Communications on March 28, 2006, based on Sub-section 1.1 of Article 6 of the Ministry's Rule for Enforcement of Radio Law of Japan,
2. Use EVMs only after User obtains the license of Test Radio Station as provided in Radio Law of Japan with respect to EVMs, or
3. Use of EVMs only after User obtains the Technical Regulations Conformity Certification as provided in Radio Law of Japan with respect to EVMs. Also, do not transfer EVMs, unless User gives the same notice above to the transferee. Please note that if User does not follow the instructions above, User will be subject to penalties of Radio Law of Japan.

【無線電波を送信する製品の開発キットをお使いになる際の注意事項】 開発キットの中には技術基準適合証明を受けていないものがあります。技術適合証明を受けていないものご使用に際しては、電波法遵守のため、以下のいずれかの措置を取っていただく必要がありますのでご注意ください。

1. 電波法施行規則第6条第1項第1号に基づく平成18年3月28日総務省告示第173号で定められた電波暗室等の試験設備でご使用いただく。
2. 実験局の免許を取得後ご使用いただく。
3. 技術基準適合証明を取得後ご使用いただく。

なお、本製品は、上記の「ご使用にあたっての注意」を譲渡先、移転先に通知しない限り、譲渡、移転できないものとします。

上記を遵守頂けない場合は、電波法の罰則が適用される可能性があることをご留意ください。日本テキサス・インスツルメンツ株式会社

東京都新宿区西新宿 6 丁目 2 4 番 1 号

西新宿三井ビル

3.3.3 *Notice for EVMs for Power Line Communication:* Please see [http://www.tij.co.jp/llds/ti\\_ja/general/eStore/notice\\_02.page](http://www.tij.co.jp/llds/ti_ja/general/eStore/notice_02.page)

電力線搬送波通信についての開発キットをお使いになる際の注意事項については、次のところをご覧ください。[http://www.tij.co.jp/llds/ti\\_ja/general/eStore/notice\\_02.page](http://www.tij.co.jp/llds/ti_ja/general/eStore/notice_02.page)

#### 4 *EVM Use Restrictions and Warnings:*

4.1 EVMS ARE NOT FOR USE IN FUNCTIONAL SAFETY AND/OR SAFETY CRITICAL EVALUATIONS, INCLUDING BUT NOT LIMITED TO EVALUATIONS OF LIFE SUPPORT APPLICATIONS.

4.2 User must read and apply the user guide and other available documentation provided by TI regarding the EVM prior to handling or using the EVM, including without limitation any warning or restriction notices. The notices contain important safety information related to, for example, temperatures and voltages.

#### 4.3 *Safety-Related Warnings and Restrictions:*

4.3.1 User shall operate the EVM within TI's recommended specifications and environmental considerations stated in the user guide, other available documentation provided by TI, and any other applicable requirements and employ reasonable and customary safeguards. Exceeding the specified performance ratings and specifications (including but not limited to input and output voltage, current, power, and environmental ranges) for the EVM may cause personal injury or death, or property damage. If there are questions concerning performance ratings and specifications, User should contact a TI field representative prior to connecting interface electronics including input power and intended loads. Any loads applied outside of the specified output range may also result in unintended and/or inaccurate operation and/or possible permanent damage to the EVM and/or interface electronics. Please consult the EVM user guide prior to connecting any load to the EVM output. If there is uncertainty as to the load specification, please contact a TI field representative. During normal operation, even with the inputs and outputs kept within the specified allowable ranges, some circuit components may have elevated case temperatures. These components include but are not limited to linear regulators, switching transistors, pass transistors, current sense resistors, and heat sinks, which can be identified using the information in the associated documentation. When working with the EVM, please be aware that the EVM may become very warm.

4.3.2 EVMs are intended solely for use by technically qualified, professional electronics experts who are familiar with the dangers and application risks associated with handling electrical mechanical components, systems, and subsystems. User assumes all responsibility and liability for proper and safe handling and use of the EVM by User or its employees, affiliates, contractors or designees. User assumes all responsibility and liability to ensure that any interfaces (electronic and/or mechanical) between the EVM and any human body are designed with suitable isolation and means to safely limit accessible leakage currents to minimize the risk of electrical shock hazard. User assumes all responsibility and liability for any improper or unsafe handling or use of the EVM by User or its employees, affiliates, contractors or designees.

4.4 User assumes all responsibility and liability to determine whether the EVM is subject to any applicable international, federal, state, or local laws and regulations related to User's handling and use of the EVM and, if applicable, User assumes all responsibility and liability for compliance in all respects with such laws and regulations. User assumes all responsibility and liability for proper disposal and recycling of the EVM consistent with all applicable international, federal, state, and local requirements.

5. *Accuracy of Information:* To the extent TI provides information on the availability and function of EVMs, TI attempts to be as accurate as possible. However, TI does not warrant the accuracy of EVM descriptions, EVM availability or other information on its websites as accurate, complete, reliable, current, or error-free.

6. *Disclaimers:*
- 6.1 EXCEPT AS SET FORTH ABOVE, EVMS AND ANY WRITTEN DESIGN MATERIALS PROVIDED WITH THE EVM (AND THE DESIGN OF THE EVM ITSELF) ARE PROVIDED "AS IS" AND "WITH ALL FAULTS." TI DISCLAIMS ALL OTHER WARRANTIES, EXPRESS OR IMPLIED, REGARDING SUCH ITEMS, INCLUDING BUT NOT LIMITED TO ANY IMPLIED WARRANTIES OF MERCHANTABILITY OR FITNESS FOR A PARTICULAR PURPOSE OR NON-INFRINGEMENT OF ANY THIRD PARTY PATENTS, COPYRIGHTS, TRADE SECRETS OR OTHER INTELLECTUAL PROPERTY RIGHTS.
- 6.2 EXCEPT FOR THE LIMITED RIGHT TO USE THE EVM SET FORTH HEREIN, NOTHING IN THESE TERMS AND CONDITIONS SHALL BE CONSTRUED AS GRANTING OR CONFERRING ANY RIGHTS BY LICENSE, PATENT, OR ANY OTHER INDUSTRIAL OR INTELLECTUAL PROPERTY RIGHT OF TI, ITS SUPPLIERS/LICENSORS OR ANY OTHER THIRD PARTY, TO USE THE EVM IN ANY FINISHED END-USER OR READY-TO-USE FINAL PRODUCT, OR FOR ANY INVENTION, DISCOVERY OR IMPROVEMENT MADE, CONCEIVED OR ACQUIRED PRIOR TO OR AFTER DELIVERY OF THE EVM.
7. *USER'S INDEMNITY OBLIGATIONS AND REPRESENTATIONS.* USER WILL DEFEND, INDEMNIFY AND HOLD TI, ITS LICENSORS AND THEIR REPRESENTATIVES HARMLESS FROM AND AGAINST ANY AND ALL CLAIMS, DAMAGES, LOSSES, EXPENSES, COSTS AND LIABILITIES (COLLECTIVELY, "CLAIMS") ARISING OUT OF OR IN CONNECTION WITH ANY HANDLING OR USE OF THE EVM THAT IS NOT IN ACCORDANCE WITH THESE TERMS AND CONDITIONS. THIS OBLIGATION SHALL APPLY WHETHER CLAIMS ARISE UNDER STATUTE, REGULATION, OR THE LAW OF TORT, CONTRACT OR ANY OTHER LEGAL THEORY, AND EVEN IF THE EVM FAILS TO PERFORM AS DESCRIBED OR EXPECTED.
8. *Limitations on Damages and Liability:*
- 8.1 *General Limitations.* IN NO EVENT SHALL TI BE LIABLE FOR ANY SPECIAL, COLLATERAL, INDIRECT, PUNITIVE, INCIDENTAL, CONSEQUENTIAL, OR EXEMPLARY DAMAGES IN CONNECTION WITH OR ARISING OUT OF THESE TERMS AND CONDITIONS OR THE USE OF THE EVMS PROVIDED HEREUNDER, REGARDLESS OF WHETHER TI HAS BEEN ADVISED OF THE POSSIBILITY OF SUCH DAMAGES. EXCLUDED DAMAGES INCLUDE, BUT ARE NOT LIMITED TO, COST OF REMOVAL OR REINSTALLATION, ANCILLARY COSTS TO THE PROCUREMENT OF SUBSTITUTE GOODS OR SERVICES, RETESTING, OUTSIDE COMPUTER TIME, LABOR COSTS, LOSS OF GOODWILL, LOSS OF PROFITS, LOSS OF SAVINGS, LOSS OF USE, LOSS OF DATA, OR BUSINESS INTERRUPTION. NO CLAIM, SUIT OR ACTION SHALL BE BROUGHT AGAINST TI MORE THAN ONE YEAR AFTER THE RELATED CAUSE OF ACTION HAS OCCURRED.
- 8.2 *Specific Limitations.* IN NO EVENT SHALL TI'S AGGREGATE LIABILITY FROM ANY WARRANTY OR OTHER OBLIGATION ARISING OUT OF OR IN CONNECTION WITH THESE TERMS AND CONDITIONS, OR ANY USE OF ANY TI EVM PROVIDED HEREUNDER, EXCEED THE TOTAL AMOUNT PAID TO TI FOR THE PARTICULAR UNITS SOLD UNDER THESE TERMS AND CONDITIONS WITH RESPECT TO WHICH LOSSES OR DAMAGES ARE CLAIMED. THE EXISTENCE OF MORE THAN ONE CLAIM AGAINST THE PARTICULAR UNITS SOLD TO USER UNDER THESE TERMS AND CONDITIONS SHALL NOT ENLARGE OR EXTEND THIS LIMIT.
9. *Return Policy.* Except as otherwise provided, TI does not offer any refunds, returns, or exchanges. Furthermore, no return of EVM(s) will be accepted if the package has been opened and no return of the EVM(s) will be accepted if they are damaged or otherwise not in a resalable condition. If User feels it has been incorrectly charged for the EVM(s) it ordered or that delivery violates the applicable order, User should contact TI. All refunds will be made in full within thirty (30) working days from the return of the components(s), excluding any postage or packaging costs.
10. *Governing Law:* These terms and conditions shall be governed by and interpreted in accordance with the laws of the State of Texas, without reference to conflict-of-laws principles. User agrees that non-exclusive jurisdiction for any dispute arising out of or relating to these terms and conditions lies within courts located in the State of Texas and consents to venue in Dallas County, Texas. Notwithstanding the foregoing, any judgment may be enforced in any United States or foreign court, and TI may seek injunctive relief in any United States or foreign court.

Mailing Address: Texas Instruments, Post Office Box 655303, Dallas, Texas 75265  
Copyright © 2015, Texas Instruments Incorporated

## IMPORTANT NOTICE

Texas Instruments Incorporated and its subsidiaries (TI) reserve the right to make corrections, enhancements, improvements and other changes to its semiconductor products and services per JESD46, latest issue, and to discontinue any product or service per JESD48, latest issue. Buyers should obtain the latest relevant information before placing orders and should verify that such information is current and complete. All semiconductor products (also referred to herein as "components") are sold subject to TI's terms and conditions of sale supplied at the time of order acknowledgment.

TI warrants performance of its components to the specifications applicable at the time of sale, in accordance with the warranty in TI's terms and conditions of sale of semiconductor products. Testing and other quality control techniques are used to the extent TI deems necessary to support this warranty. Except where mandated by applicable law, testing of all parameters of each component is not necessarily performed.

TI assumes no liability for applications assistance or the design of Buyers' products. Buyers are responsible for their products and applications using TI components. To minimize the risks associated with Buyers' products and applications, Buyers should provide adequate design and operating safeguards.

TI does not warrant or represent that any license, either express or implied, is granted under any patent right, copyright, mask work right, or other intellectual property right relating to any combination, machine, or process in which TI components or services are used. Information published by TI regarding third-party products or services does not constitute a license to use such products or services or a warranty or endorsement thereof. Use of such information may require a license from a third party under the patents or other intellectual property of the third party, or a license from TI under the patents or other intellectual property of TI.

Reproduction of significant portions of TI information in TI data books or data sheets is permissible only if reproduction is without alteration and is accompanied by all associated warranties, conditions, limitations, and notices. TI is not responsible or liable for such altered documentation. Information of third parties may be subject to additional restrictions.

Resale of TI components or services with statements different from or beyond the parameters stated by TI for that component or service voids all express and any implied warranties for the associated TI component or service and is an unfair and deceptive business practice. TI is not responsible or liable for any such statements.

Buyer acknowledges and agrees that it is solely responsible for compliance with all legal, regulatory and safety-related requirements concerning its products, and any use of TI components in its applications, notwithstanding any applications-related information or support that may be provided by TI. Buyer represents and agrees that it has all the necessary expertise to create and implement safeguards which anticipate dangerous consequences of failures, monitor failures and their consequences, lessen the likelihood of failures that might cause harm and take appropriate remedial actions. Buyer will fully indemnify TI and its representatives against any damages arising out of the use of any TI components in safety-critical applications.

In some cases, TI components may be promoted specifically to facilitate safety-related applications. With such components, TI's goal is to help enable customers to design and create their own end-product solutions that meet applicable functional safety standards and requirements. Nonetheless, such components are subject to these terms.

No TI components are authorized for use in FDA Class III (or similar life-critical medical equipment) unless authorized officers of the parties have executed a special agreement specifically governing such use.

Only those TI components which TI has specifically designated as military grade or "enhanced plastic" are designed and intended for use in military/aerospace applications or environments. Buyer acknowledges and agrees that any military or aerospace use of TI components which have **not** been so designated is solely at the Buyer's risk, and that Buyer is solely responsible for compliance with all legal and regulatory requirements in connection with such use.

TI has specifically designated certain components as meeting ISO/TS16949 requirements, mainly for automotive use. In any case of use of non-designated products, TI will not be responsible for any failure to meet ISO/TS16949.

### Products

Audio	<a href="http://www.ti.com/audio">www.ti.com/audio</a>
Amplifiers	<a href="http://amplifier.ti.com">amplifier.ti.com</a>
Data Converters	<a href="http://dataconverter.ti.com">dataconverter.ti.com</a>
DLP® Products	<a href="http://www.dlp.com">www.dlp.com</a>
DSP	<a href="http://dsp.ti.com">dsp.ti.com</a>
Clocks and Timers	<a href="http://www.ti.com/clocks">www.ti.com/clocks</a>
Interface	<a href="http://interface.ti.com">interface.ti.com</a>
Logic	<a href="http://logic.ti.com">logic.ti.com</a>
Power Mgmt	<a href="http://power.ti.com">power.ti.com</a>
Microcontrollers	<a href="http://microcontroller.ti.com">microcontroller.ti.com</a>
RFID	<a href="http://www.ti-rfid.com">www.ti-rfid.com</a>
OMAP Applications Processors	<a href="http://www.ti.com/omap">www.ti.com/omap</a>
Wireless Connectivity	<a href="http://www.ti.com/wirelessconnectivity">www.ti.com/wirelessconnectivity</a>

### Applications

Automotive and Transportation	<a href="http://www.ti.com/automotive">www.ti.com/automotive</a>
Communications and Telecom	<a href="http://www.ti.com/communications">www.ti.com/communications</a>
Computers and Peripherals	<a href="http://www.ti.com/computers">www.ti.com/computers</a>
Consumer Electronics	<a href="http://www.ti.com/consumer-apps">www.ti.com/consumer-apps</a>
Energy and Lighting	<a href="http://www.ti.com/energy">www.ti.com/energy</a>
Industrial	<a href="http://www.ti.com/industrial">www.ti.com/industrial</a>
Medical	<a href="http://www.ti.com/medical">www.ti.com/medical</a>
Security	<a href="http://www.ti.com/security">www.ti.com/security</a>
Space, Avionics and Defense	<a href="http://www.ti.com/space-avionics-defense">www.ti.com/space-avionics-defense</a>
Video and Imaging	<a href="http://www.ti.com/video">www.ti.com/video</a>

### TI E2E Community

[e2e.ti.com](http://e2e.ti.com)