

## Bluetooth® 4.2 Low Energy Module

### Features

- Fully Qualified Bluetooth® Smart Module
- On-Board Bluetooth 4.2 Low Energy Stack
- ASCII Command Interface API over UART
- Scripting Engine for Hostless Operation
- Compact Form Factor – The RN4870/71 family comes in four different sizes from 6 mm x 8 mm to 12 mm x 22 mm:
  - RN4870: 12 mm x 22 mm
  - RN4871: 9 mm x 11.5 mm
  - RN4870U: 12 mm x 15 mm
  - RN4871U: 6 mm x 8 mm
- Beacon Private Service for Beacon Services
- UART Transparent Service for Serial Data Applications
- Remote Configuration Over The Air

### Operational

- Operating Voltage: 1.9V to 3.6V (3.3V typical)
- Temperature Range: -20°C to +70°C
- Supports UART
- Up to Three Pulse Width Modulation (PWM) Outputs

### RF/Analog Features

- ISM Band 2.402 to 2.480 GHz Operation
- Channels: 0-39
- RX Sensitivity: -90 dBm
- TX Power: 0 dBm
- RSSI Monitor

### MAC/Baseband/Higher Layer Features

- Secure AES128 Encryption
- GAP, GATT, SM, L2CAP and Integrated Public Profiles
- Customer Can Create up to Five Public and Four Private Services
- Keyboard I/O Authentication
- Software Configurable Role as Peripheral or Central and Client or Server

### Antenna Options

- Ceramic Chip Antenna (RN4870/RN4871)
- External Antenna Connection via RF pad (RN4870U/RN4871U)

### Applications

- Health/Medical Devices
- Sports Activity/Fitness Meters
- Beacon Applications
- Internet of Things (IoT) Sensor Tag
- Remote Control
- Wearable Smart Devices and Accessories
- Smart Energy/Smart Home
- Industrial Control



### Description

The RN487x modules, based on Microchip's IS187x Bluetooth LE ICs, provide a complete solution to implement Bluetooth 4.2 Low Energy connectivity. These modules are interfaced via a two- or four-wire UART interface with Microchip's simple ASCII command set for easy integration into most applications. All products in the RN series can be dynamically configured by the host microcontroller with a few simple ASCII commands. The RN487x series also supports on-board scripting to automate basic operations without a host microcontroller. The RN4870 (12 mm x 22 mm) and RN4871 (9 mm x 11.5 mm) modules combine Microchip's Bluetooth LE Silicon with all necessary peripheral components and an on-board chip antenna to create an easy to use/drop-in solution. All modules in this series are Bluetooth SIG qualified. The RN4870 and RN4871 include FCC modular certification, as well as most other worldwide government regulatory approvals. For a listing of the latest certifications, go to [www.microchip.com/wireless](http://www.microchip.com/wireless). The RN4870U (12 mm x 15 mm) and RN4871U (6 mm x 8 mm) offer compact, flexible, unshielded options for designs that are extremely space constrained or need to remotely locate the antenna.

## Table of Contents

1.0	Device Overview .....	3
2.0	Specifications .....	9
3.0	Interface PINs.....	11
4.0	Physical Dimensions And Attributes .....	13
5.0	Application Reference Circuits .....	23
6.0	ASCII Command API.....	29
7.0	Supported Services .....	31
8.0	Antenna Characteristics .....	33
9.0	Timing Characteristics .....	35
10.0	Regulatory Approval .....	37
11.0	Ordering Information .....	43
	The Microchip Web Site .....	45
	Customer Change Notification Service .....	45
	Customer Support .....	45
	Product Identification System.....	46

## TO OUR VALUED CUSTOMERS

It is our intention to provide our valued customers with the best documentation possible to ensure successful use of your Microchip products. To this end, we will continue to improve our publications to better suit your needs. Our publications will be refined and enhanced as new volumes and updates are introduced.

If you have any questions or comments regarding this publication, please contact the Marketing Communications Department via E-mail at [docerrors@microchip.com](mailto:docerrors@microchip.com). We welcome your feedback.

### Most Current Data Sheet

To obtain the most up-to-date version of this data sheet, please register at our Worldwide Web site at:

<http://www.microchip.com>

You can determine the version of a data sheet by examining its literature number found on the bottom outside corner of any page. The last character of the literature number is the version number, (e.g., DS30000000A is version A of document DS30000000).

### Errata

An errata sheet, describing minor operational differences from the data sheet and recommended workarounds, may exist for current devices. As device/documentation issues become known to us, we will publish an errata sheet. The errata will specify the revision of silicon and revision of document to which it applies.

To determine if an errata sheet exists for a particular device, please check with one of the following:

- Microchip's Worldwide Web site; <http://www.microchip.com>
- Your local Microchip sales office (see last page)

When contacting a sales office, please specify which device, revision of silicon and data sheet (include literature number) you are using.

### Customer Notification System

Register on our web site at [www.microchip.com](http://www.microchip.com) to receive the most current information on all of our products.

## 1.0 DEVICE OVERVIEW

### 1.1 Overview

The RN4870/71 Bluetooth Low Energy (BLE) modules integrate Bluetooth 4.2 baseband controller, on-board Bluetooth stack, digital and analog I/O, and RF power amplifier into one solution.

Table 1-1 shows the various options for packaging and features available in the RN4870/71 family. Table 1-2 provides the description of the pin functions for all the modules in the RN4870/71 family. Figure 1-1 through Figure 1-4 show the pinout for the different modules.

**TABLE 1-1: RN4870/71 FAMILY**

Part Number <sup>(1)</sup>	Antenna On-Board	Shielding	Number of Pins	Dimensions
RN4870-V/RM118	Yes	Yes	33	12 mm x 22 mm
RN4870U-V/RM118	No	No	30	12 mm x 15 mm
RN4871-V/RM118	Yes	Yes	16	9 mm x 11.5 mm
RN4871U-V/RM118	No	No	17	6 mm x 8 mm

**Note 1:** The last three digits in P/N indicate firmware version. At the time of publication, the latest firmware version is 1.18. Ensure to check product webpage for latest part number and firmware version.

**TABLE 1-2: PIN DESCRIPTION**

RN4870U	RN4870	RN4871U	RN4871	Name	Type	Description
—	1	—	—	GND	Power	Ground reference
—	2	—	—	GND	Power	Ground reference
1	3	12	13	GND	Power	Ground reference
2	4	11	14	VBAT	Power	Positive supply input. Range: 1.9V~3.6V
—	—	10	—	BK_IN	Power	Buck power supply input Can be connected to the VBAT pin Connect to 10 $\mu$ F low ESR ceramic capacitor Voltage range: 1.9V to 3.6V
3	5	—	—	P2_2	D I/O	GPIO PWM1 Default: Input; pulled-high
4	6	—	—	VDD_IO	Power	VDD; power input Same input pin as VBAT Can be connected to the VBAT pin
5	7	—	—	VDD_IO	Power	VDD; power input Same input pin as VBAT Can be connected to the VBAT pin
6	8	—	—	ULPC_O	Power	1.2V ULPC LDO output Used for diagnostic purposes <i>Do not connect</i> to any pin or device For measurement, connect a bypass 1 $\mu$ F capacitor to ground
7	9	—	—	P2_3	D I/O	GPIO PWM2 Default: Input; pulled-high
8	10	—	—	BK_O	Power	1.55V Buck power supply output for diagnostic purpose <i>Do not connect</i>
—	—	13	6	P1_6	D I/O A O/p	GPIO
—	—	14	5	P1_7	D I/O A O/p	GPIO

# RN4870/71

**TABLE 1-2: PIN DESCRIPTION (CONTINUED)**

RN4870U	RN4870	RN4871U	RN4871	Name	Type	Description
9	11	15	15	P2_7	D I/O A I/p	GPIO; default: Input; pulled-high AD14 Configured as the TX_IND pin by default
10	12	—	—	P1_1	D I/O A I/p	GPIO; default: Input; pulled-high AD9 Configured as the BLEDK_STATUS1_IND pin by default
11	13	2	3	P1_2	D I/O A I/p	GPIO; default: Input; pulled-high AD10
12	14	3	4	P1_3	D I/O	GPIO; default: Input; pulled-high AD11
13	15	8	11	P0_0	D I/O	GPIO; default: Input; pulled-high AD0 Configured as the UART_CTS pin by default
14	16	—	—	P1_0	D I/O	GPIO; default: Input; pulled-high AD8 Configured as the BLEDK_STATUS2_IND pin by default
15	17	6	9	P3_6	D I/O	GPIO; default: Input; pulled-high PWM0 Configured as the UART_RTS pin by default
16	18	16	16	P2_0	D I/p	System configuration input; 1: Application mode 0: Test mode, for Flash update and EEPROM settings Default: Input; pulled-high
17	19	—	—	P2_4	D I/O	GPIO; default: Input; pulled-high
18	20	—	—	NC	—	No Connection
19	21	7	10	RST_N	D I/p	Module Reset; active-low; Internally pulled-high
20	22	5	7	UART_RX	D I/p	UART Data input
21	23	4	8	UART_TX	D O/p	UART Data output
22	24	—	—	P3_1	D I/O	GPIO; default: Input; pulled-high Configured as RSSI_IND pin by default
23	25	—	—	P3_2	D I/p	GPIO; default: Input; pulled-high Configured as the LINK_DROP pin by default
24	26	—	—	P3_3	D I/p	GPIO; default: Input; pulled-high Configured as the UART RX Indication pin by default
25	27	—	—	P3_4	D I/p	GPIO; default: Input; pulled-high Configured as the PAIRING_KEY pin by default
26	28	—	—	P3_5	D I/O A I/p	GPIO; default: Input; pulled-high LED1; provides indication whether the module is ON/OFF
27	29	—	—	P0_7	D I/O	GPIO; default: Input; pulled-high Configured to the LOW_BATTERY_INDICATOR pin by default
28	30	9	12	P0_2	D I/O	AD2 LED0: Provides indication whether the module is in ON/OFF mode
29	31	17	2	GND	Power	Ground Reference
—	32	—	—	GND	Power	Ground Reference

**TABLE 1-2: PIN DESCRIPTION (CONTINUED)**

RN4870U	RN4870	RN4871U	RN4871	Name	Type	Description
30	—	1	1	BT_RF	A I/O	External Antenna connection (50 ohms)
—	33	—	—	GND	Power	Ground Reference

**Legend:** Pin Type Abbreviations: A = Analog D = Digital I/O = Input/Output I/p = Input O/p = Output

**FIGURE 1-1: PIN DIAGRAM - RN4870U**

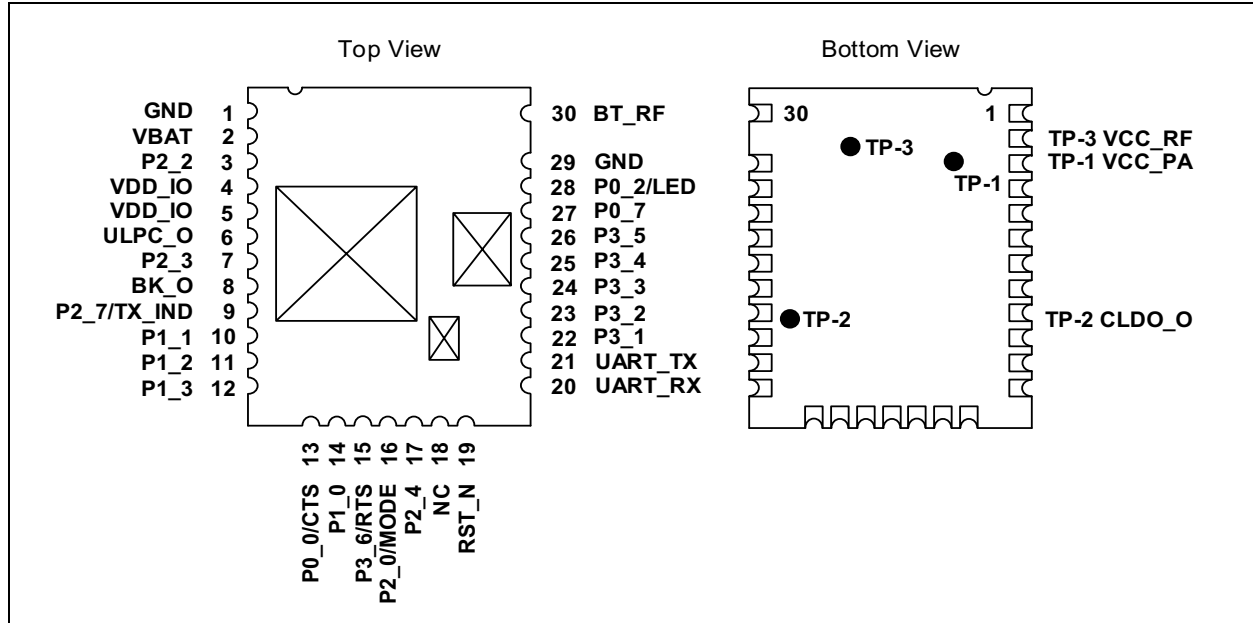

**FIGURE 1-2: PIN DIAGRAM - RN4870**

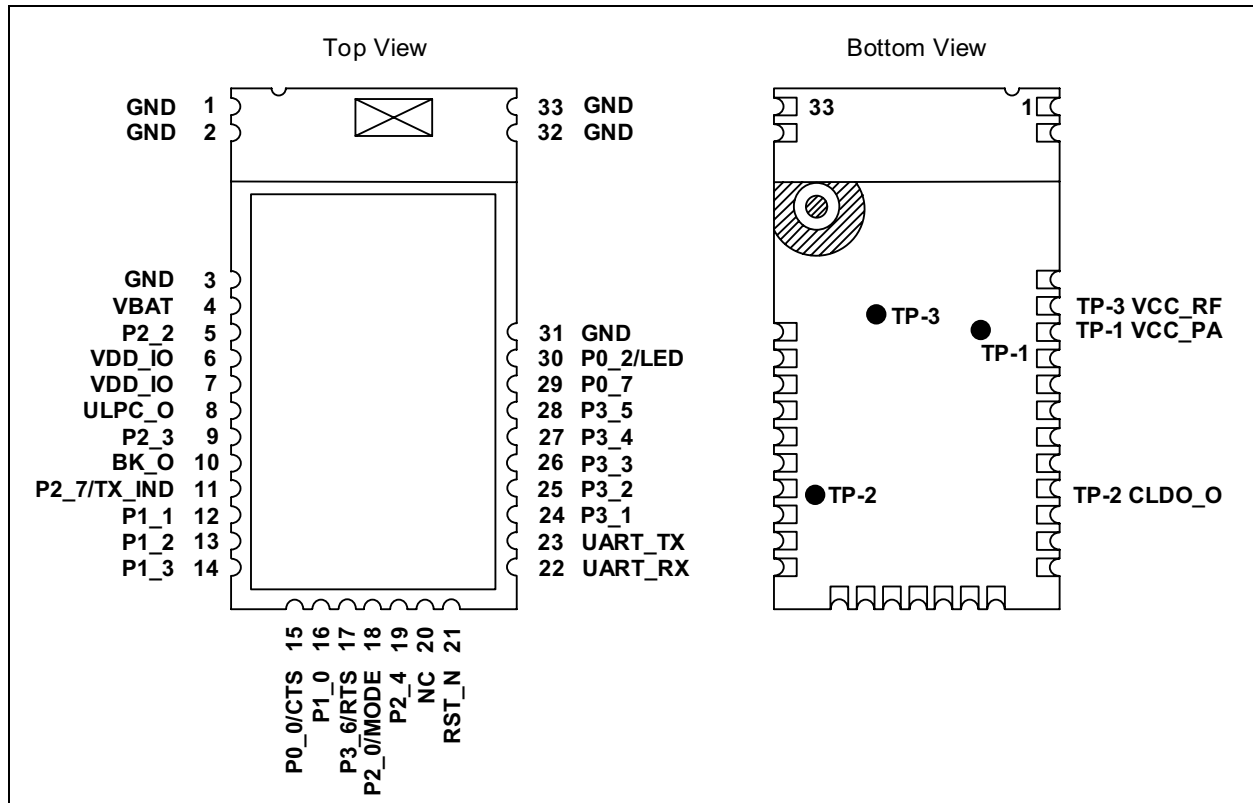

# RN4870/71

FIGURE 1-3: PIN DIAGRAM - RN4871U

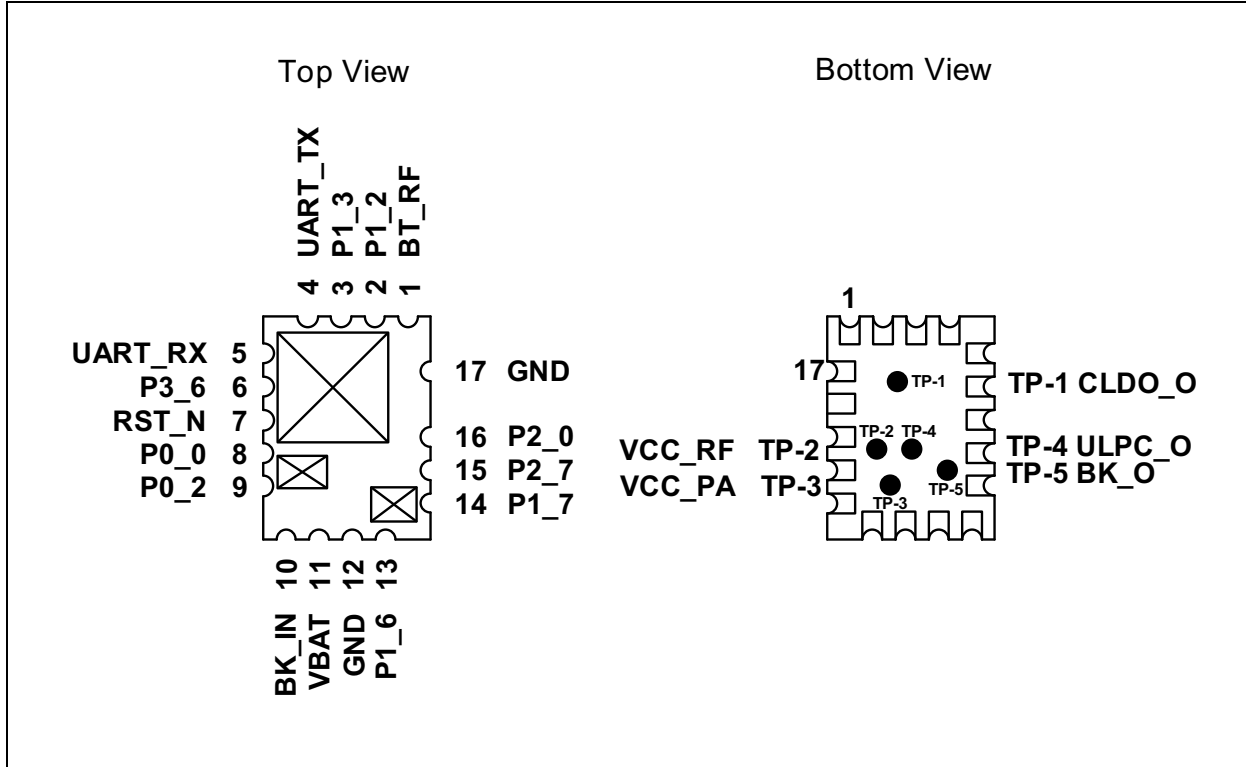
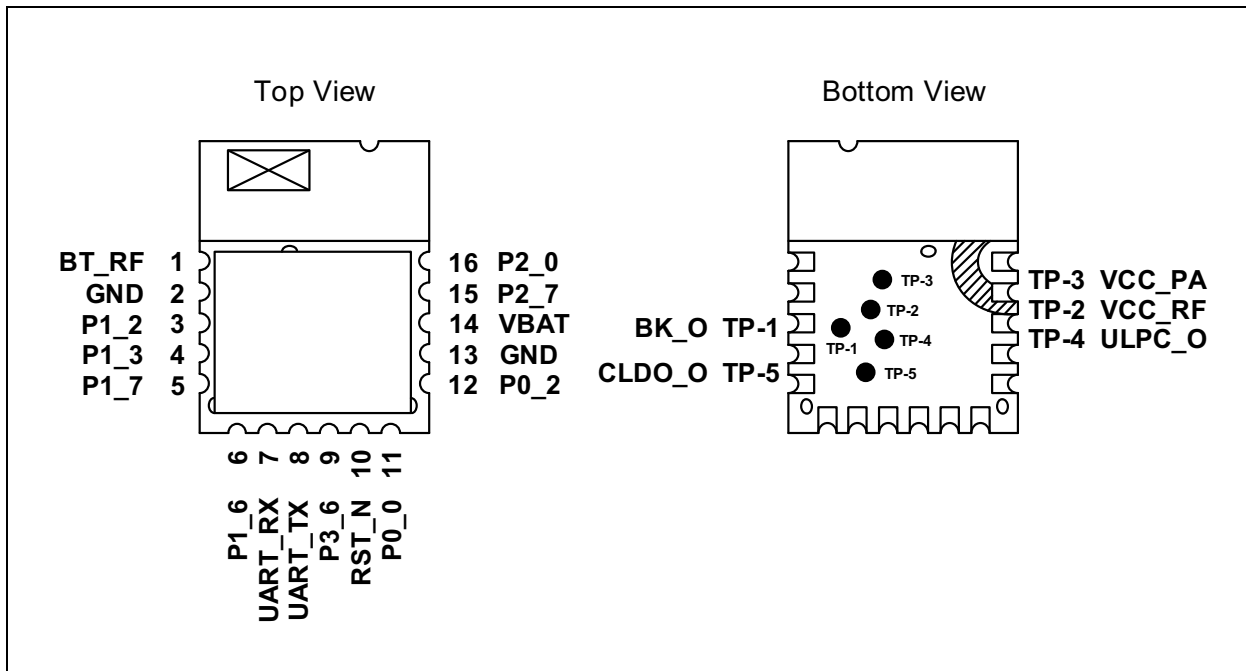

FIGURE 1-4: PIN DIAGRAM - RN4871



## 1.2 Module Configuration

The GPIO pins of the RN4870 and RN4871 modules can be configured to different functions using the ASCII command interface. [Table 1-3](#) shows the various pins in the RN4870/71 module that are available for configuration and their default configuration settings. [Table 1-4](#) provides details on each functions available.

[Table 1-5](#) shows the status of the module as indicated by the Status 1 and Status 2 indication pins. [Table 1-6](#) shows the details of test pads that are present on the bottom side of the module, used for diagnostic purposes during testing. [Figure 1-5](#) shows all the key elements of the module.

**TABLE 1-3: CONFIGURABLE PINS AND DEFAULT FUNCTIONS IN THE RN4870 AND RN4871**

Pin Name	Available in		Default Function
	RN4870	RN4871	
P0_7	x	—	Low Battery Indication
P1_0	x	—	Status 2
P1_1	x	—	Status 1
P2_2	x	—	None
P2_4	x	—	None
P3_1	x	—	RSSI Indication
P3_2	x	—	Link Drop
P3_3	x	—	UART RX Indication
P3_4	x	—	Pairing Key
P3_5	x	—	None
P1_2	x	x	None
P1_3	x	x	None
P1_6	—	x	UART RX Indication
P1_7	—	x	None

**TABLE 1-4: CONFIGURABLE FUNCTIONS AND DESCRIPTIONS**

Function Name	Description
Low Battery Indication	Pin output goes low when the VDD is below a specified level. To set the threshold level, change the EEPROM settings.
Status 1	Use this indication pin along with the Status 2 pin to indicate the current status of the module. Refer to <a href="#">Table 1-5</a> for details of the status indication.
Status 2	Use this indication pin along with the Status 1 pin to indicate the current status of the module. Refer to <a href="#">Table 1-5</a> for details of the status indication.
RSSI Indication	Use this indication pin to indicate the quality of the link based on the RSSI level. If the RSSI level is lower than the specified threshold value, then the RSSI indication pin goes low. Set the threshold for the RSSI link quality in EEPROM.
Link Drop	Use this pin to force the module to drop the current BLE link with a peer device. Pulling the Link Drop pin low forces the connection to close. The pin needs to be pulled low for at least 10 ms.
UART RX Indication	Use this pin to enable communication with the UART when the module is in Low-Power mode. When <i>not</i> in Low-Power mode, the module runs on a 16 MHz clock. If Low-Power mode is enabled on the module by using command <code>SO, 1</code> , the module runs on a 32 kHz clock thus reducing power consumption. However, in Low-Power mode, the host MCU <i>cannot</i> communicate with the module via the UART since the UART is <i>not</i> operational. If the user intends to provide data or commands via UART in the Low-Power mode, then the UART RX INDICATION pin must be pulled low and the user needs to wait for at least five milliseconds before sending the data. Pulling the UART RX INDICATION pin low allows the module to operate the 16 MHz clock and to enable UART.

# RN4870/71

**TABLE 1-4: CONFIGURABLE FUNCTIONS AND DESCRIPTIONS (CONTINUED)**

Function Name	Description
Pairing Key	Use this pin to force the module to enter Standby mode. The pin must be pulled down for at least 160 ms.
RF Active Indication	Use this indication pin to indicate that the module is currently performing an active transmission and receiving BLE data.

**TABLE 1-5: STATUS INDICATION PINS**

Status 1	Status 2	State
High	High	Power On
High	Low	Standby state
Low	Low	Connection established
Low	High	Data session open (Transparent UART)

**TABLE 1-6: TEST POINTS ON THE BOTTOM SIDE**

RN4870U	RN4870	RN4871U	RN4871	Symbol	Description
TP-1	TP-1	TP-3	TP-3	VCC_PA	1.55V RF PA LDO
TP-2	TP-2	TP-1	TP-5	CLDO_O	1.2V CLDO Output
TP-3	TP-3	TP-2	TP-2	VCC_RF	1.2V RF LDO Output
—	—	TP-4	TP-4	ULPC_O	1.2V ULPC LDO Output
—	—	TP-5	TP-1	BK_O	1.55V Buck Reg Output

**FIGURE 1-5: BLOCK DIAGRAM OF THE RN4870/71**

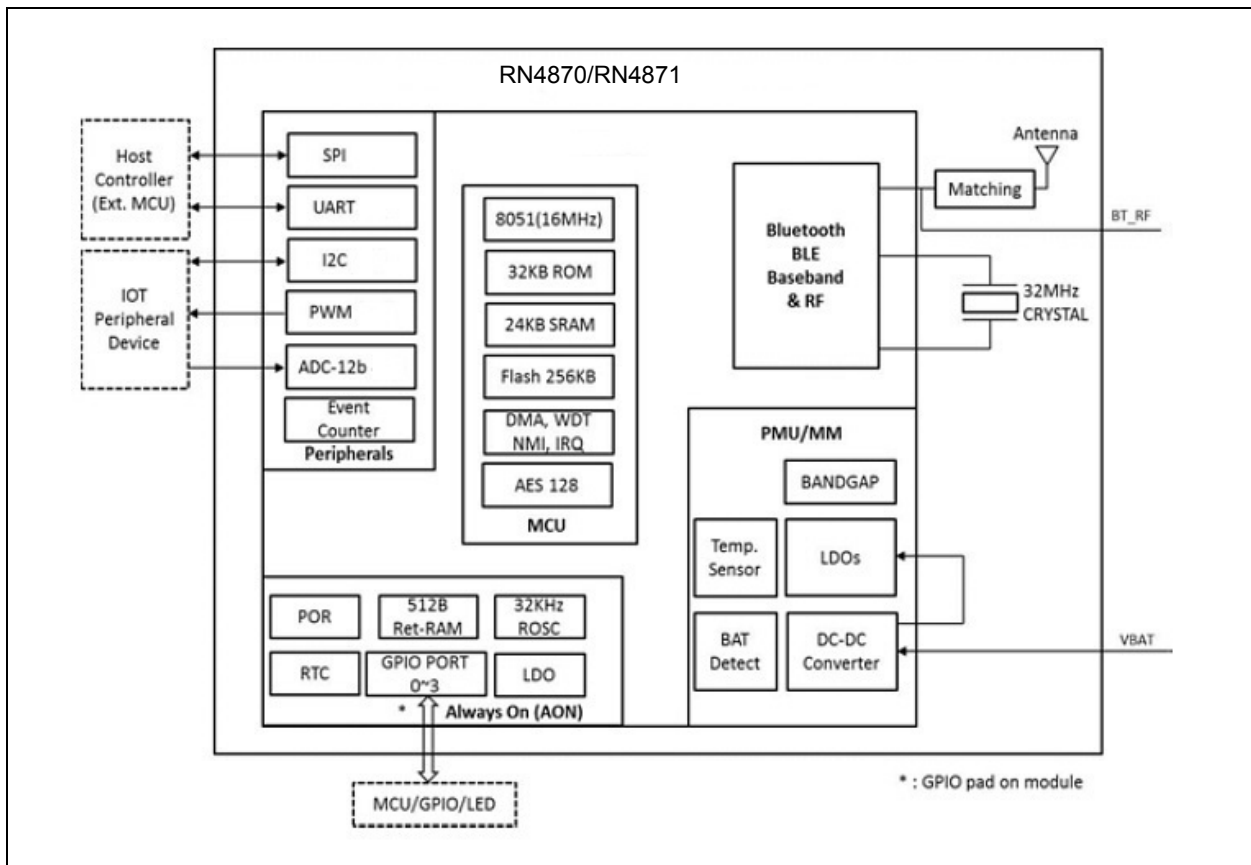



## 2.0 SPECIFICATIONS

Table 2-1 provides the general specifications for the module. Table 2-2 and Table 2-3 provide the electrical characteristics and the current consumption of the module.

**TABLE 2-1: GENERAL SPECIFICATIONS**

Specification	Description
Standard Compliance	Bluetooth 4.2
Frequency Band	2.402 to 2.480 GHz
Modulation Method	GFSK
Maximum Data Rate (Transparent UART)	10 kbps (iOS®9)
Antenna	Ceramic
Interface	UART, AIO, PIO
Operating Range	1.9V to 3.6V
Sensitivity	-90 dBm
RF TX Power	0 dBm
Operating Temperature Range	-20°C to +70°C
Storage Temperature Range	-65°C to +150°C
Operating Relative Humidity Range	10% to 90%
Storage Relative Humidity Range	10% to 90%
Moisture Sensitivity Level	2

**TABLE 2-2: ELECTRICAL CHARACTERISTICS**

Parameter	Min.	Typ.	Max.	Units
Supply Voltage (VDD)	1.9	—	3.6	V
I/O Supply Voltage (VDD_IO = VDD)	1.9	—	3.6	V
<b>I/O Voltage Levels</b>				
V <sub>IL</sub> Input Logic Levels Low	V <sub>SS</sub>	—	0.3 V <sub>DD</sub>	V
V <sub>IH</sub> Input Logic Levels High	0.7 V <sub>DD</sub>	—	V <sub>DD</sub>	V
V <sub>OL</sub> Output Logic Levels Low	V <sub>SS</sub>	—	0.2 V <sub>DD</sub>	V
V <sub>OH</sub> Output Logic Levels High	0.8 V <sub>DD</sub>	—	V <sub>DD</sub>	V
<b>Reset</b>				
V <sub>TH,RES</sub> Threshold Voltage	—	1.6	—	V
Reset Low Duration	63	—	—	ns
<b>Input and Tri-State Current with</b>				
Pull-Up Resistance	34	48	74	kΩ
Pull-Down Resistance	29	47	86	kΩ
Leakage Current	-1	—	1	μA
<b>ADC (Analog to Digital Converter)</b>				
Full Scale (BAT_IN)	0	3.0	3.6	V
Full Scale (AD0~AD15)	0	—	3.6	V
Conversion Time (ENOB 8-bit)	—	131	—	μs
Conversion Time (ENOB 10-bit)	—	387	—	μs
Operating Current	—	—	500	μA

# RN4870/71

**TABLE 2-3: CURRENT CONSUMPTION**

Parameter	Min.	Typ.	Max.	Units
<b>Supply Current</b>				
TX mode Peak Current at V <sub>DD</sub> = 3V, TX = 0 dBm, Buck mode	—	—	13	mA
RX mode Peak Current at V <sub>DD</sub> = 3V, Buck mode	—	—	13	mA
Link Static Current	—	60	—	μA
Standby Current	1.9	—	2.9	μA
Power-Saving	1	—	1.7	μA
<b>Temperature Sensor (PTS)</b>				
Temperature Range Detected	-20	—	+70	°C
Digital Output	1387	—	2448	—
Resolution	—	12	—	units/deg
Accuracy	-3	—	+3	°C
Conversion Time (ENOB 10-bit)	—	12.35	—	ms
Operating Current	—	—	200	μA

**TABLE 2-4: CURRENT CONSUMPTION DURING VARIOUS APPLICATION MODES**

Test Mode	Test Condition <sup>(1)</sup>	Average Current Consumption	Remarks
Standby mode	Advertising Interval: 100 ms	0.23 mA	—
	Advertising Interval: 500 ms	0.077 mA	—
BLE Connected mode (no data exchange)	Connection Interval: 500 ms	0.08 mA	Module set in Transparent UART mode
Transparent UART enabled Data transmission in progress	Connection Interval: 18.75 ms	3.87 mA	TX data throughput: 9.863 kBps
	Connection Interval: 40 ms	2.77 mA	TX data throughput: 4.676 kBps
Transparent UART enabled Data being received	Connection Interval: 18.75 ms	3.06 mA (write with response)	Throughput: 4.956 kBps
		3.9 mA (write with reliable Burst Transmit)	Throughput: 9.382 kBps
	Connection Interval: 40 ms	2.14 mA (write with response)	Throughput: 2.494 kBps (write with response)
		3.03 mA (write with reliable Burst Transmit)	Throughput: 5.056 kBps
Shutdown mode	—	1.44 μA	—

**Note 1:** Test conditions: Input voltage: 3.3V; Test phone: iPhone6 with iOS 9.02 version

## 3.0 INTERFACE PINS

Figure 3-1 shows the power scheme using a 3.3V low-dropout regulator to the RN487x and a host MCU. This scheme ensures that the same voltage is used for both the module and the MCU.

Figure 3-1 also shows the basic UART connections to the host MCU.

Figure 3-2 shows the recommended connections for running the RN4870/71 on coin cell battery.

**FIGURE 3-1: POWER SCHEME**

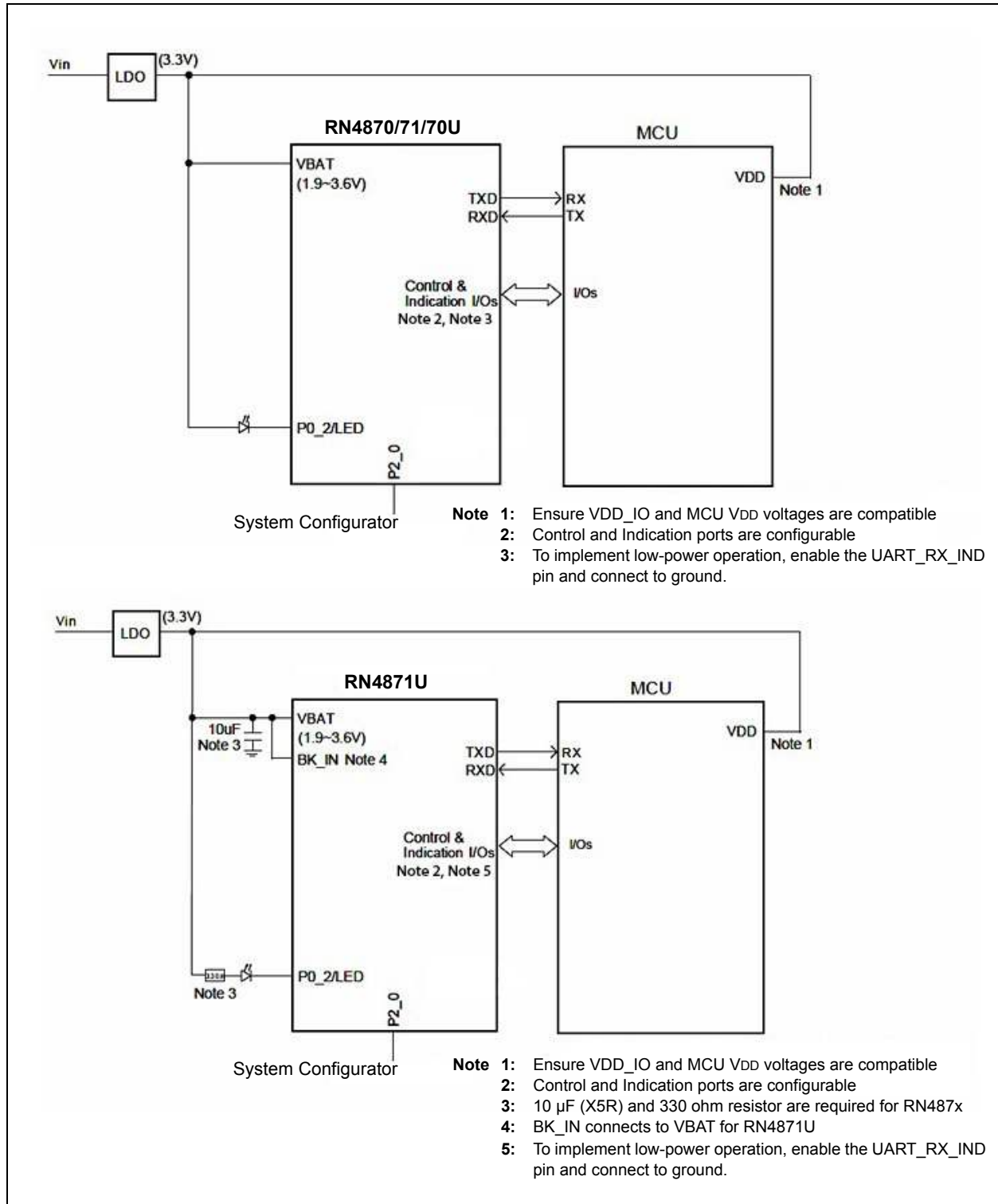

# RN4870/71

FIGURE 3-2: RN4870/71 COIN CELL POWER SCHEME

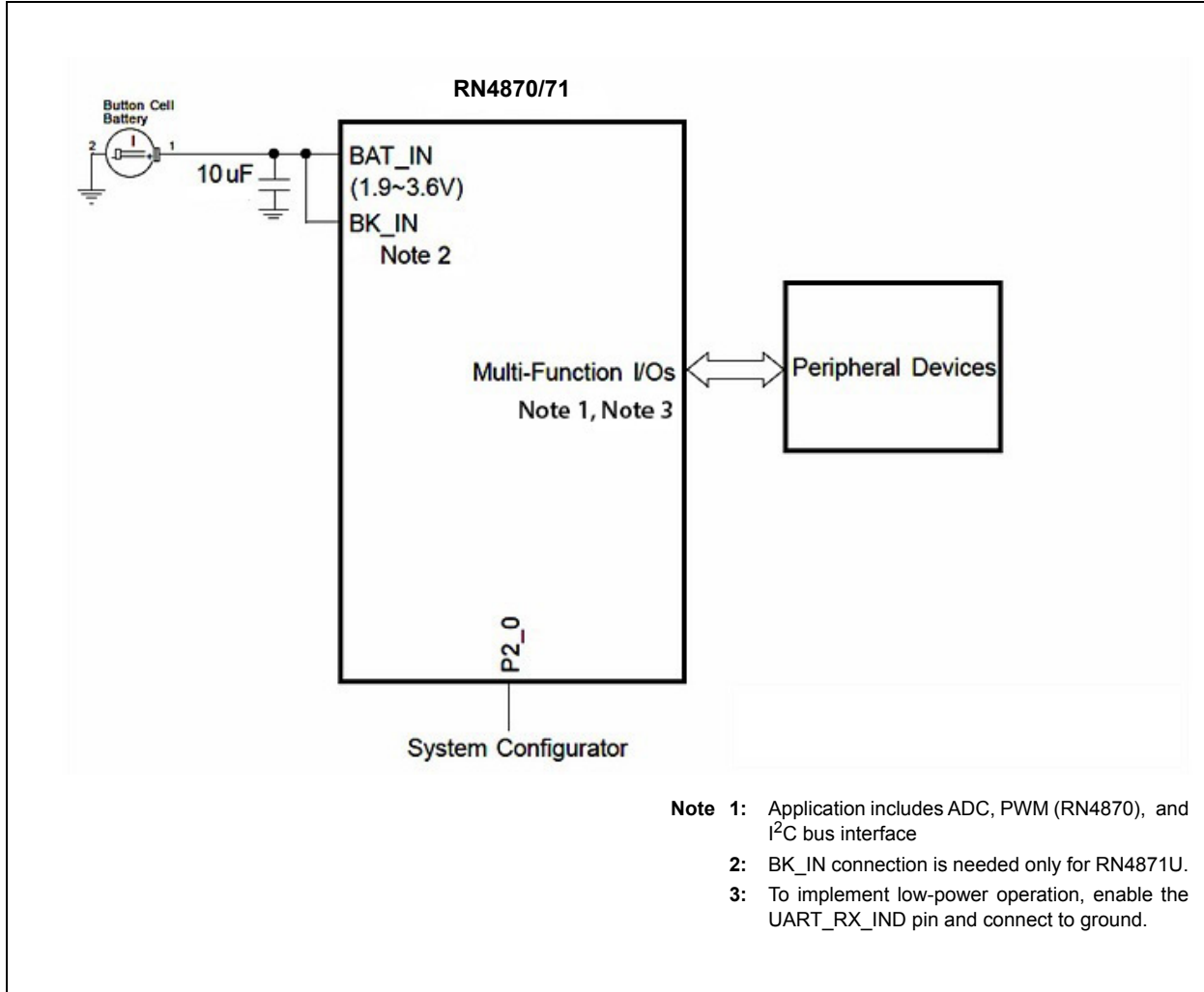

The Configuration pins on the RN4870 can also be configured through Windows®-based User Interface (UI) Configuration tool, BLEDK3.

## 4.0 PHYSICAL DIMENSIONS AND ATTRIBUTES

### 4.1 RN4870 Module

Figure 4-1 shows the physical dimensions of the RN4870 module. Figure 4-2 illustrates the recommended PCB layout, and Figure 4-3 shows the recommended mounting details.

Ensure that there is *no* top copper layer near the test pin area, indicated by the shaded *keep out areas*, as shown in Figure 4-2. When laying out the host PCB, the

areas under the antenna must *not* contain any top, inner layer, or bottom copper as shown in Figure 4-3. A low-impedance ground plane ensures the best radio performance (best range; lowest noise). Figure 4-3 also shows a minimum ground plane area to the left and right side of the module for best antenna performance. The ground plane can be extended beyond the minimum recommended as required for host PCB EMC noise reduction. For best range performance, keep all external metal at least 30 mm away from the ceramic chip antenna.

FIGURE 4-1: RN4870 MODULE DIMENSIONS

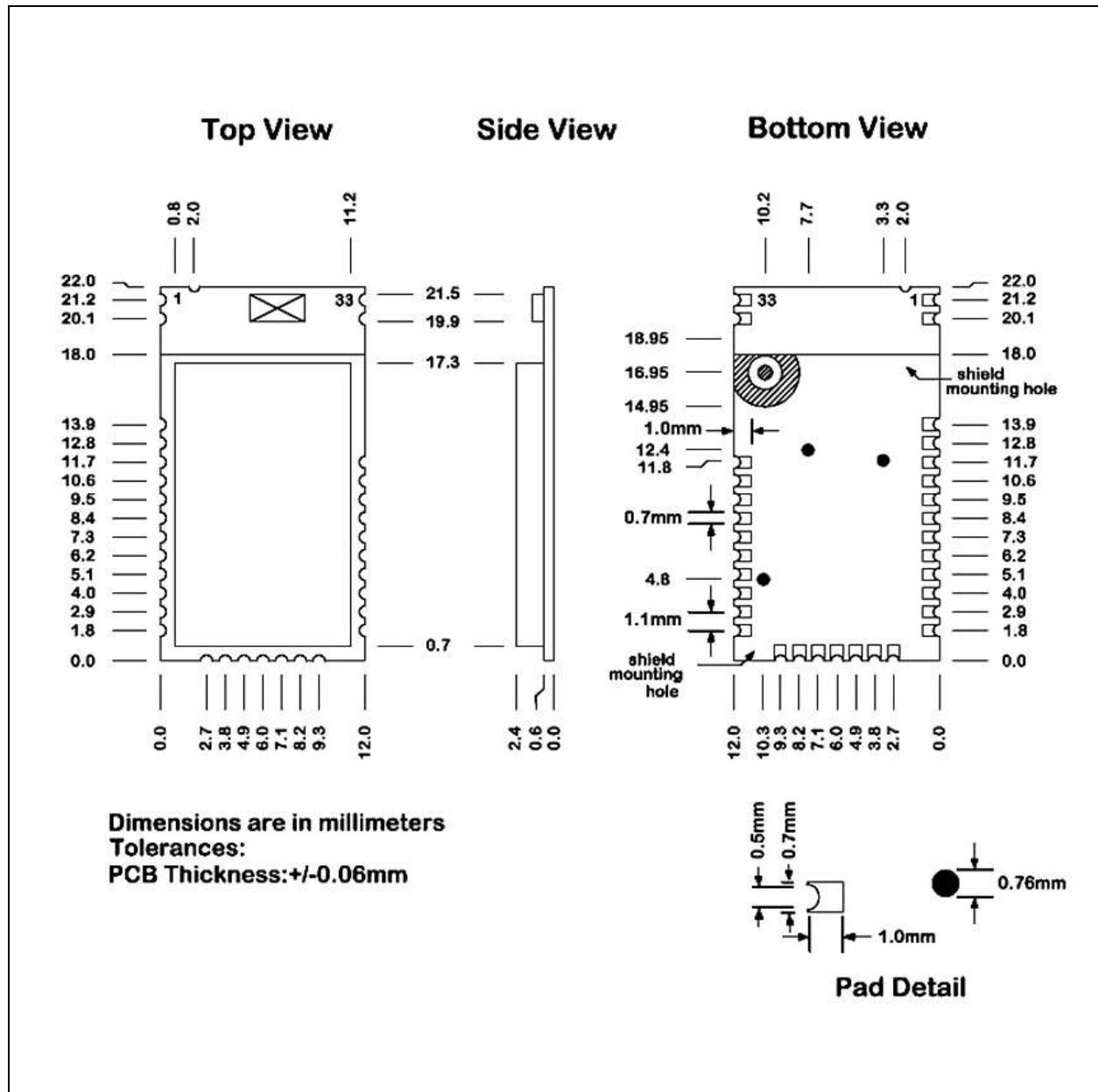

# RN4870/71

FIGURE 4-2: RN4870 RECOMMENDED PCB FOOTPRINT

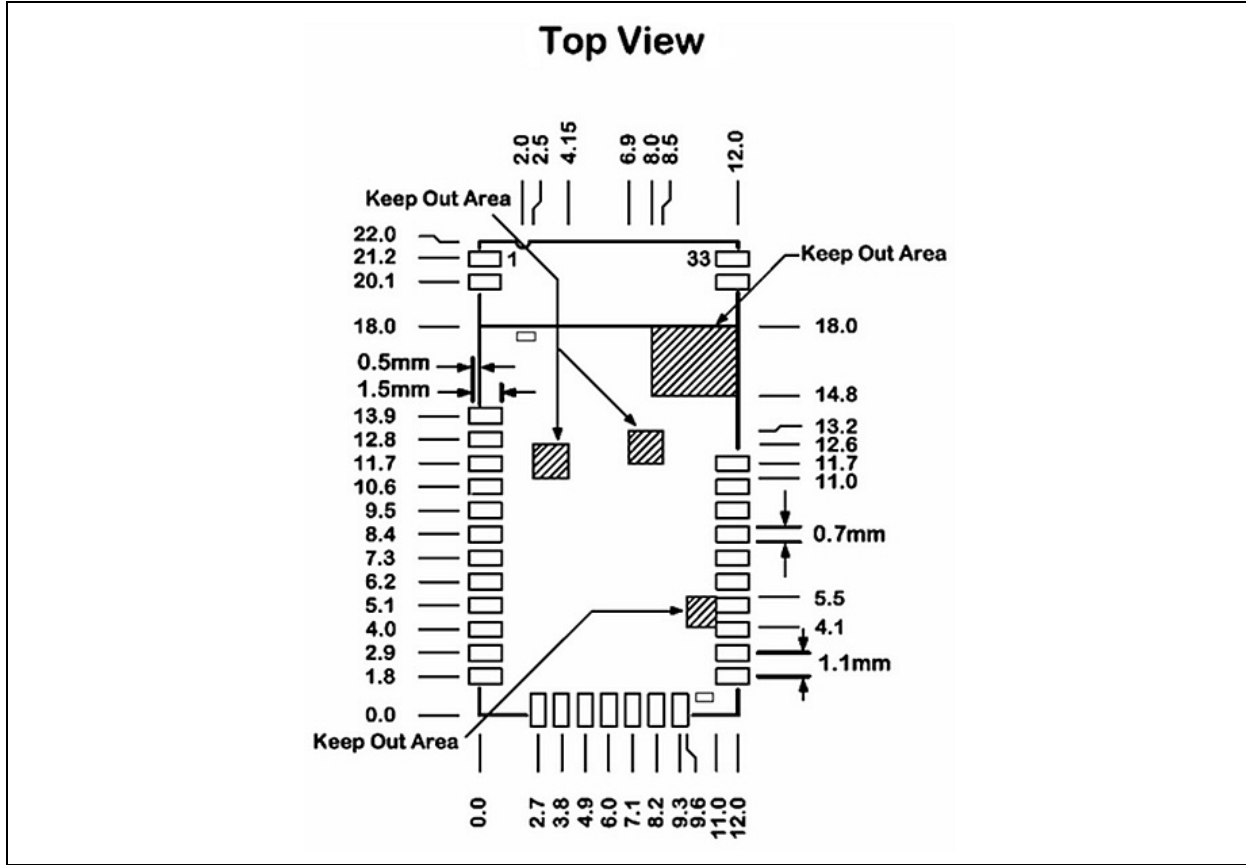
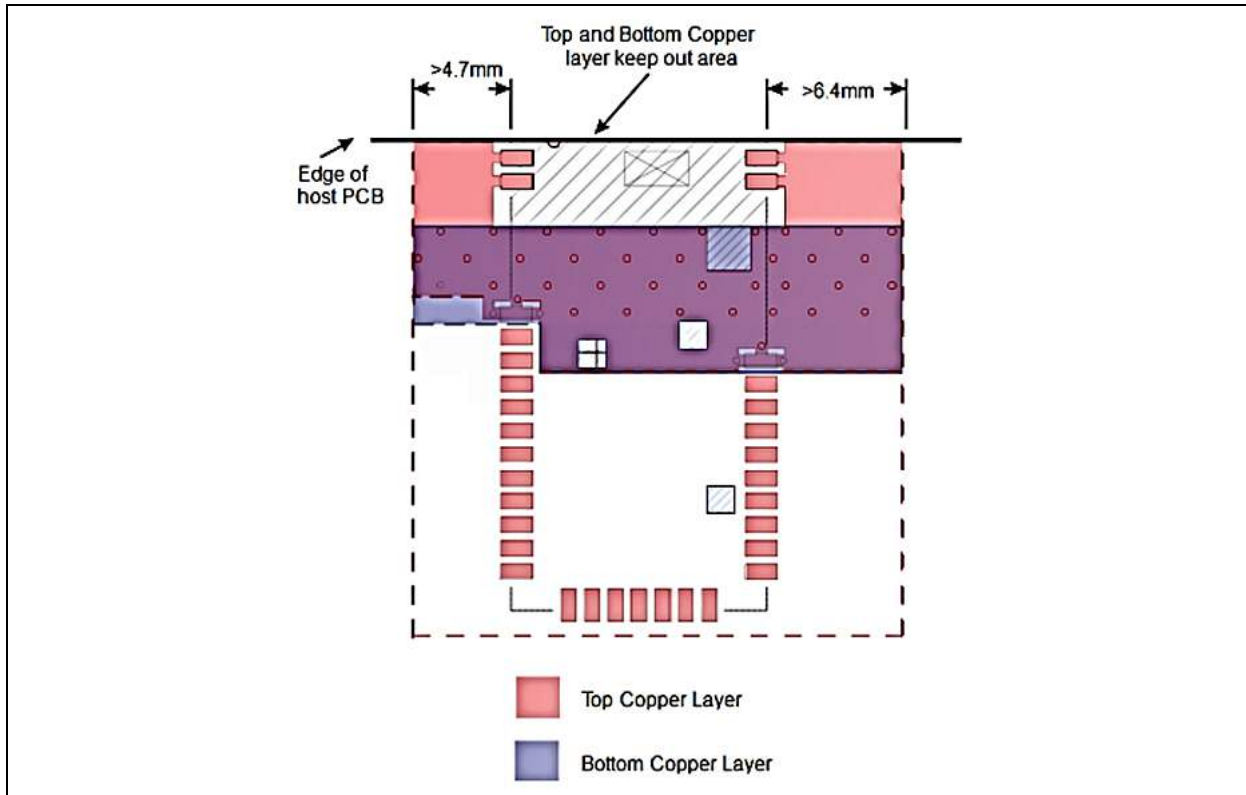

FIGURE 4-3: RECOMMENDED MOUNTING DETAILS



## 4.2 RN4870U Module

Figure 4-4 shows the physical dimensions of the RN4870U module. Figure 4-5 illustrates the recommended PCB layout, and Figure 4-6 shows the recommended mounting details.

A low-impedance ground plane ensures the best radio performance (best range; lowest noise). Pin 30 (BT\_RF) is a 50 ohm connection that can be connected

to an external antenna such as a PCB trace antenna, a component (chip) antenna, or through a host PCB 50 ohm micro-strip trace. This trace can be extended to include passive parts for antenna attenuation padding, impedance matching, or to provide test posts. It is recommended that the micro-strip trace to be as short as possible for minimum loss and best impedance matching. If the micro-strip trace is longer, a 50 ohm impedance is recommended.

FIGURE 4-4: RN4870U MODULE DIMENSIONS

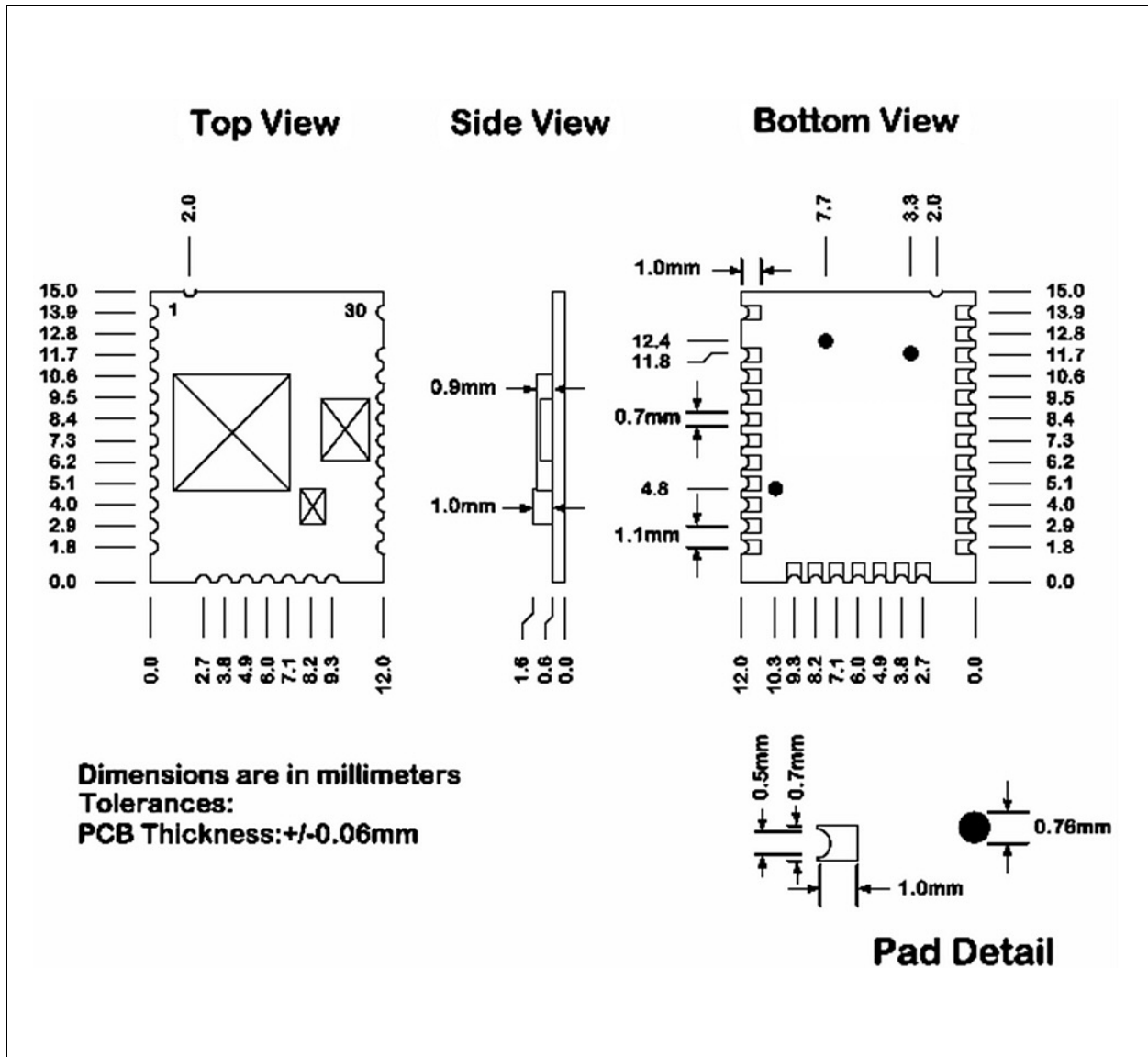

# RN4870/71

FIGURE 4-5: RN4870U RECOMMENDED PCB FOOTPRINT

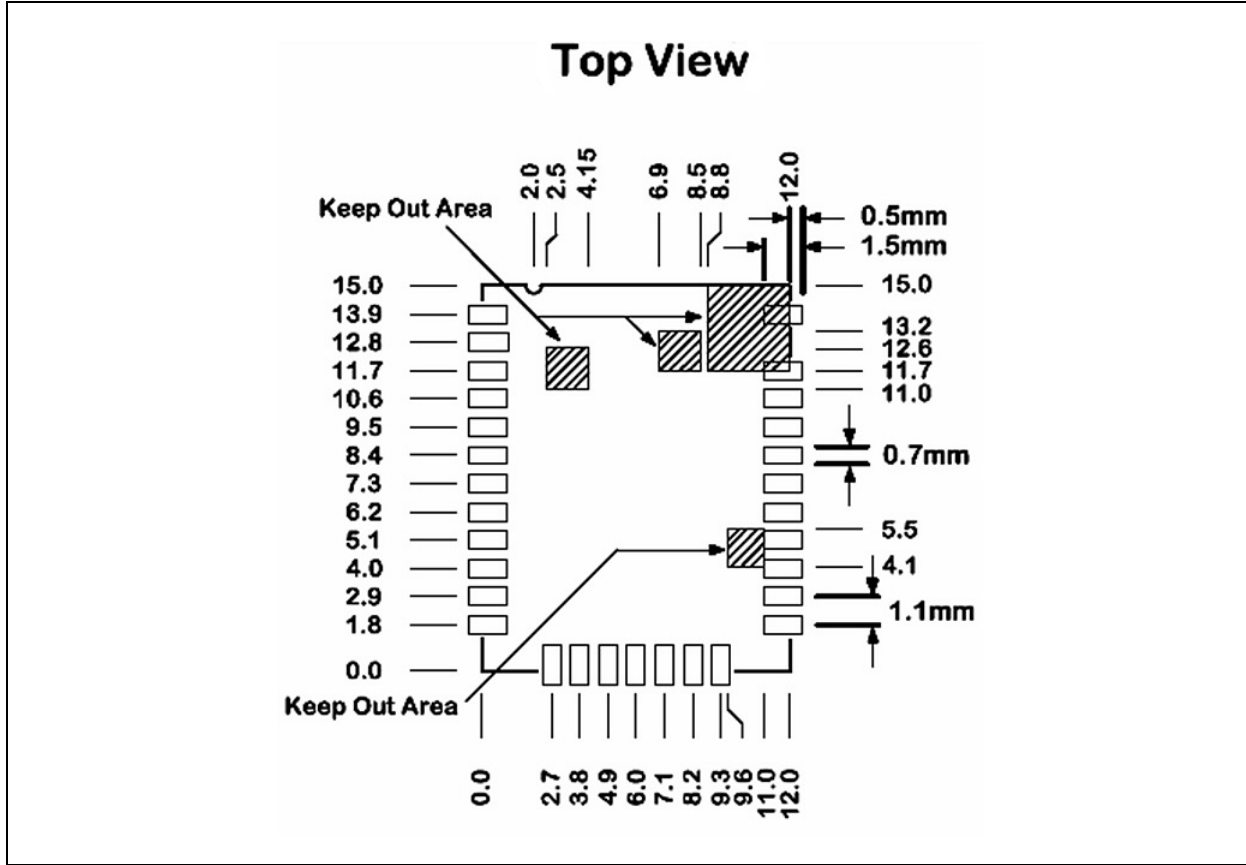
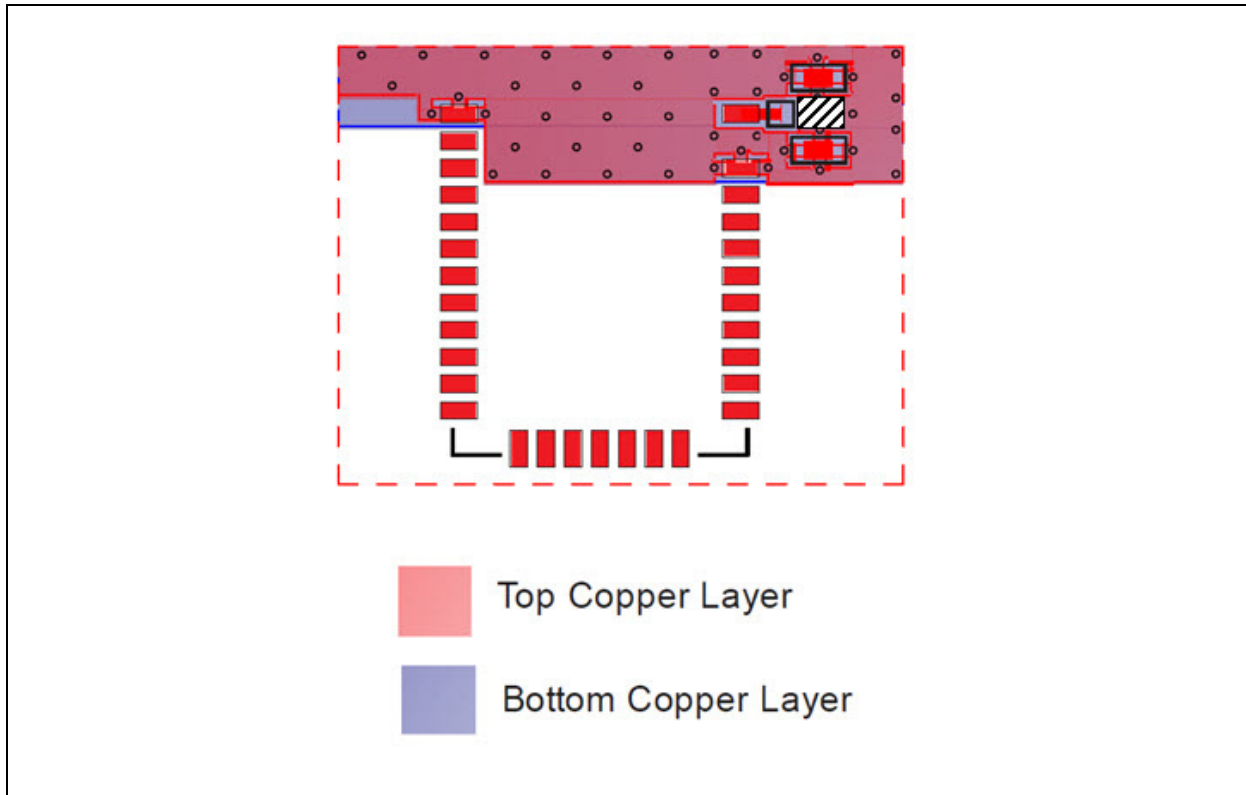

FIGURE 4-6: RN4870U RECOMMENDED PCB MOUNTING





## 4.3 RN4871 Module

Figure 4-7 shows the physical dimensions of the RN4871 module. Figure 4-8 illustrates the recommended PCB layout, and Figure 4-9 shows the recommended mounting details.

Ensure that there is *no* top copper layer near the test pin area, indicated by the shaded *keep out areas*, as shown in Figure 4-8. When laying out the host PCB, the areas under the antenna must *not* contain any top,

inner layer, or bottom copper as shown in Figure 4-9. A low-impedance ground plane ensures the best radio performance (best range; lowest noise). Figure 4-9 also shows a space area around antenna section for best antenna performance. The ground plane can be extended beyond the minimum recommended as required for host PCB EMC noise reduction. For best range performance, keep all external metal at least 30 mm away from the ceramic chip antenna.

**FIGURE 4-7: RN4871 MODULE DIMENSIONS**

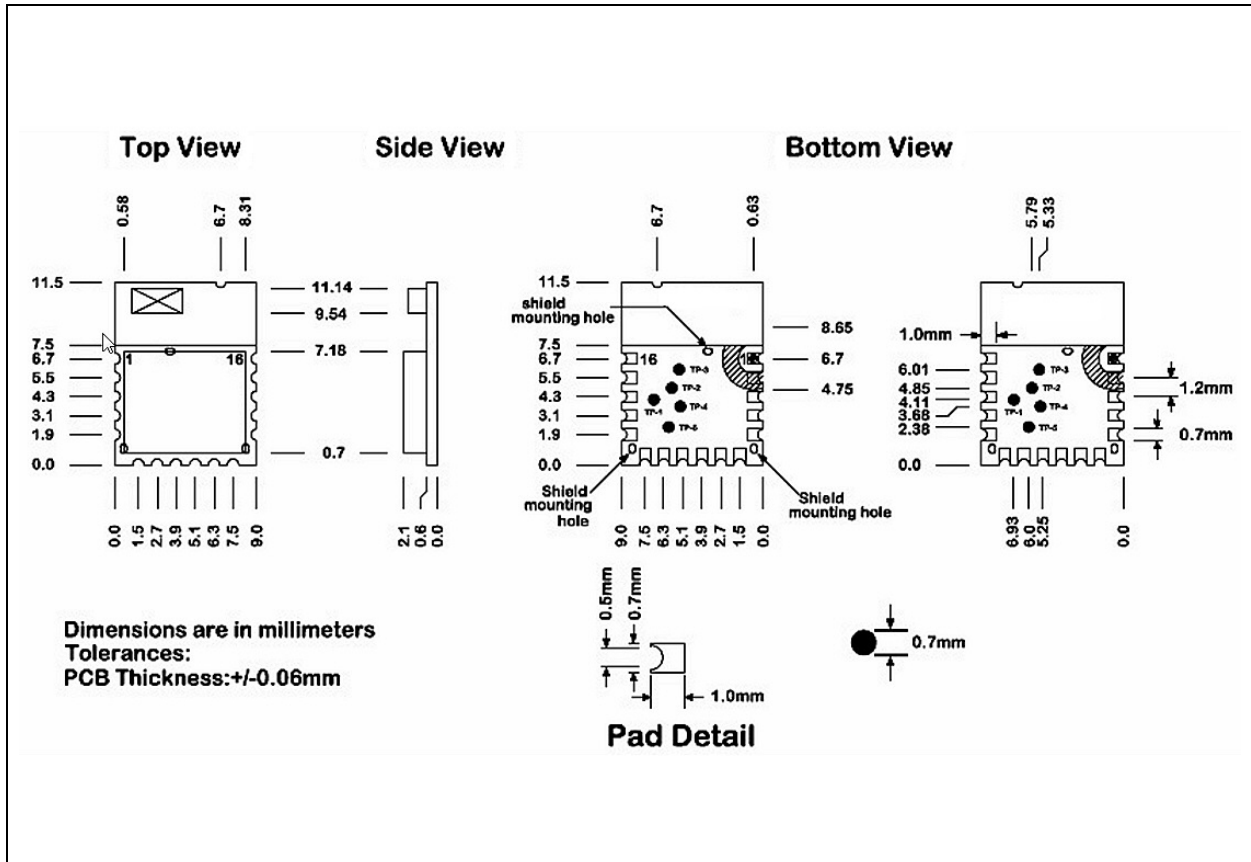

# RN4870/71

FIGURE 4-8: RN4871 RECOMMENDED PCB FOOTPRINT

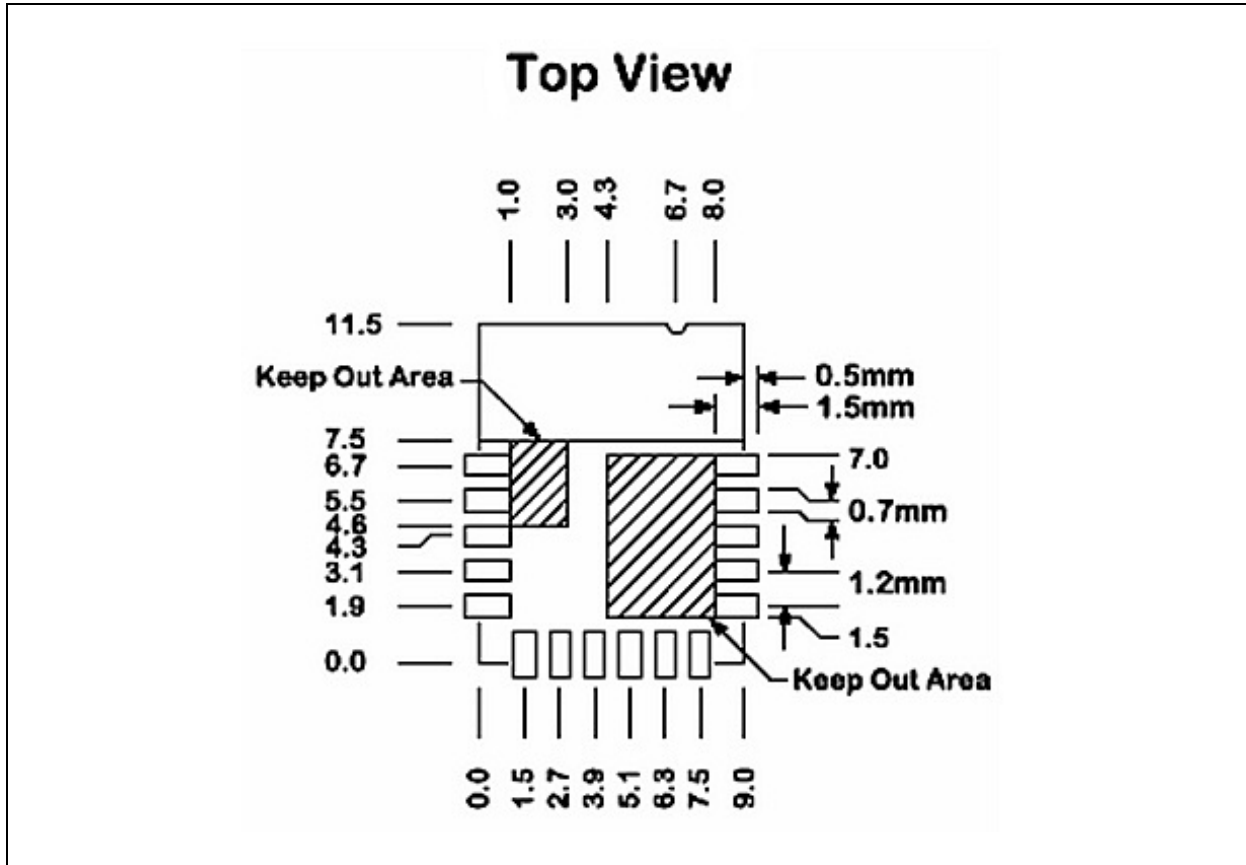
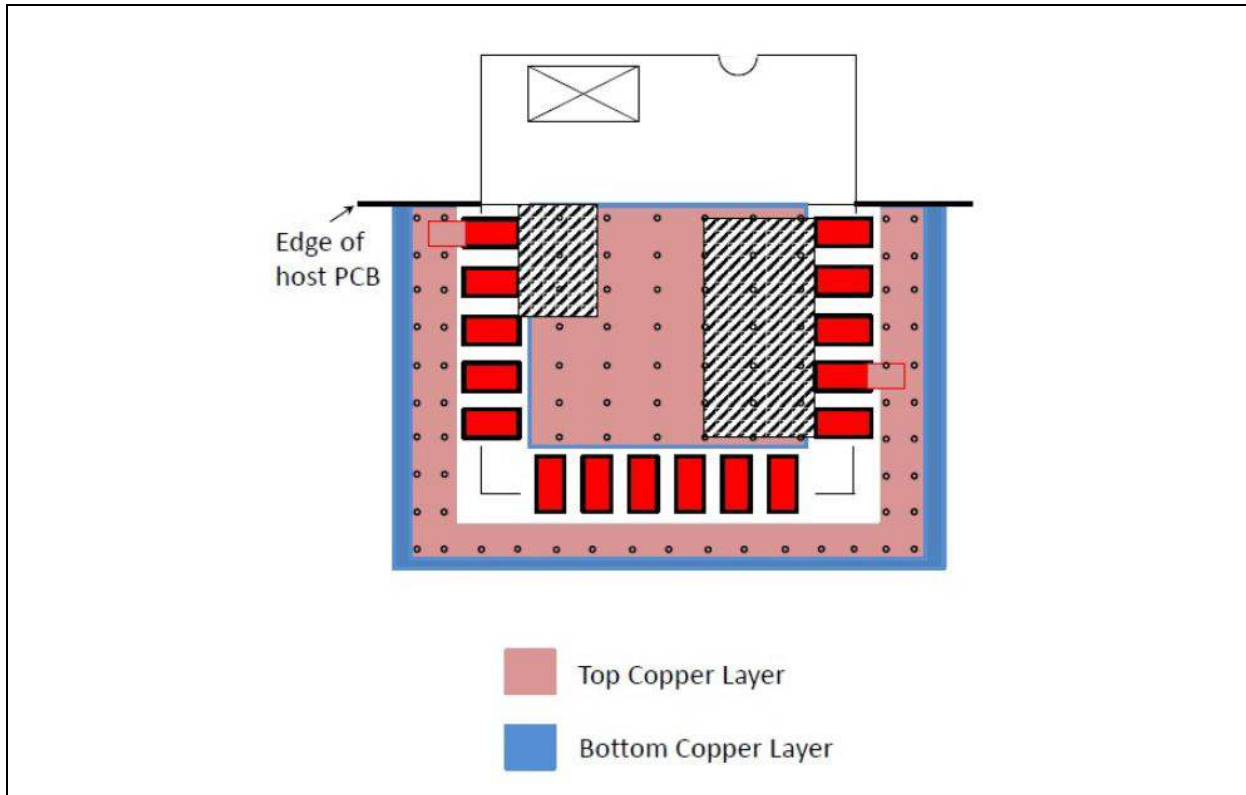

FIGURE 4-9: RN4871 RECOMMENDED PCB MOUNTING SUGGESTION



## 4.4 RN4871U Module

Figure 4-10 shows the physical dimensions of the RN4871U module. Figure 4-11 illustrates the recommended PCB layout. It is highly recommended to layout the host PCB as suggested in Figure 4-12. Figure 4-13 shows the recommended placement for the module on the host PCB board. For optimal transmission and reception sensitivity, place the module at the edge of the board.

A low-impedance ground plane ensures the best radio performance (best range; lowest noise). Pin 1 (BT\_RF) is a 50 ohm connection that can be connected to an external antenna such as a PCB trace antenna, a component (chip) antenna, or through a host PCB 50 ohm micro-strip trace. This trace can be extended to include passive parts for antenna attenuation padding, impedance matching, or to provide test posts. It is recommended that the micro-strip trace to be as short as possible for minimum loss and best impedance matching. If the micro-strip trace is longer, a 50 ohm impedance is recommended.

FIGURE 4-10: RN4871U MODULE DIMENSIONS

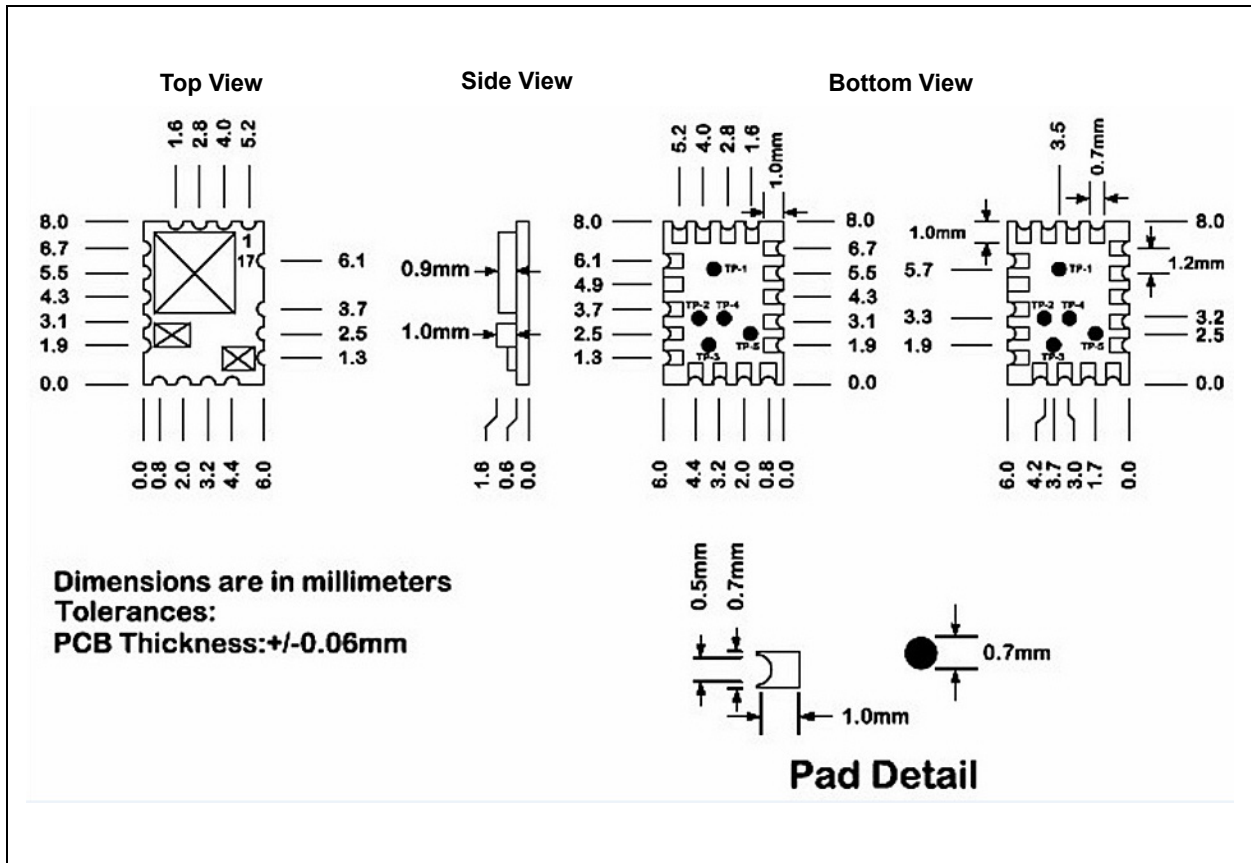

# RN4870/71

FIGURE 4-11: RN4871U RECOMMENDED PCB FOOTPRINT

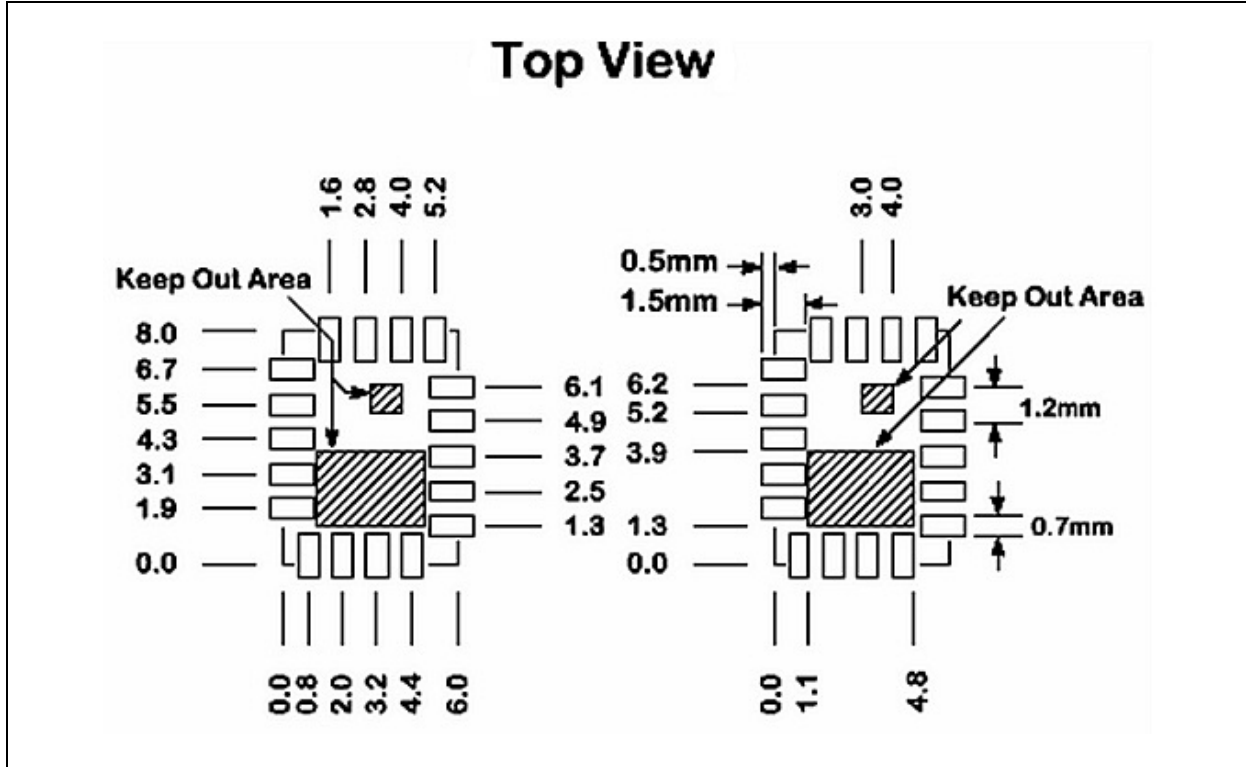
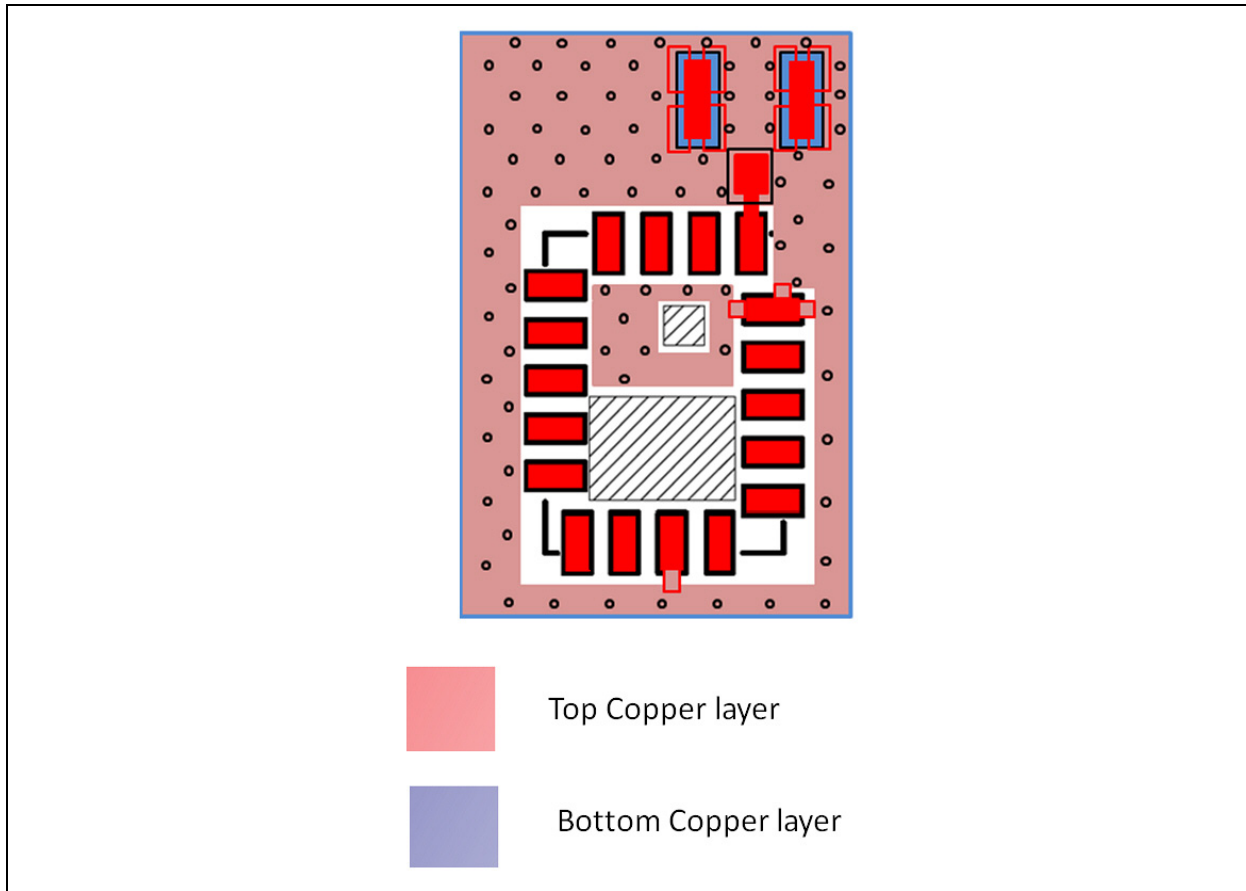
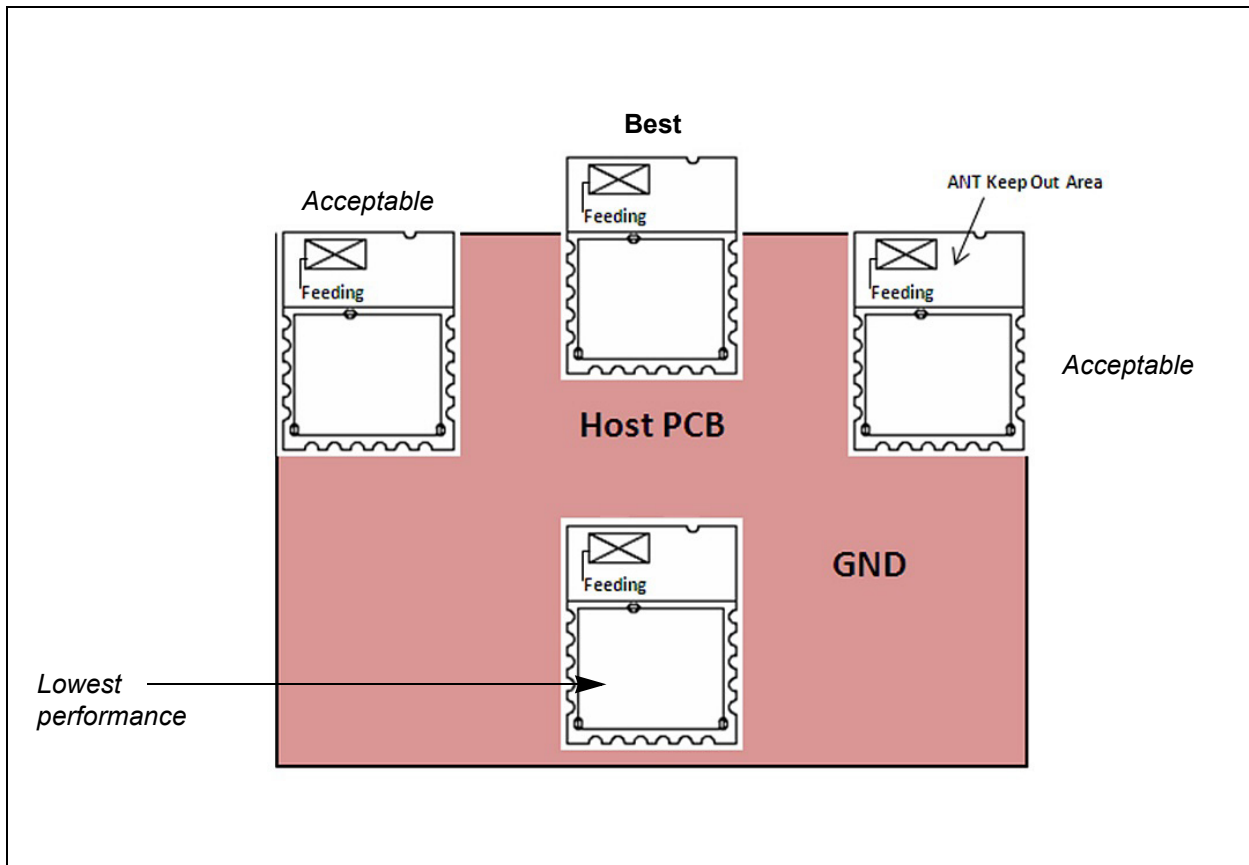

FIGURE 4-12: RN4871U RECOMMENDED PCB MOUNTING



**FIGURE 4-13: RECOMMENDATIONS FOR THE PLACEMENT OF THE MODULE ON THE HOST PCB BOARD**



## 4.5 Soldering Recommendations

The RN4870/71 Bluetooth modules are assembled using standard lead-free reflow profile IPC/JEDEC J-STD-020.

The module can be soldered to the host PCB using standard leaded and lead-free solder reflow profiles.

To avoid damaging the module, the following recommendations are given:

- Microchip Technology Application Note, "AN233 Solder Reflow Recommendation" (DS00233) provides solder reflow recommendations
- Do *not* exceed peak temperature ( $T_p$ ) of 250°C
- Refer to the solder paste data sheet for specific reflow profile recommendations
- Use no-clean flux solder paste
- Do *not* wash as moisture can be trapped under the shield
- Use only one flow. If the PCB requires multiple flows, apply the module on the final flow.

# RN4870/71

---

NOTES:

## 5.0 APPLICATION REFERENCE CIRCUITS

### 5.1 External Configuration and Programming

The RN4870/71 modules can be configured and firmware programmed using an external configuration and programming tool. [Figure 5-1](#) shows the mandatory connections required between the module and the external programming header. It is recommended to include these pin connections on the host PCB for development. For accessing the various configuration and indication pins, use [Table 1-2](#), [Table 1-3](#), [Table 1-4](#) and [Table 1-5](#).

### 5.2 Reference Circuit

[Figure 5-2](#) through [Figure 5-5](#) show the reference circuits for various modules under the RN4870/71 family. In the circuits, the power input range is 1.9V ~ 3.6V. A battery reverse protection circuit is recommended in case a battery power input is used. Note that the VDD\_IO is the same as the power input. In case of a LED connection, the power input must be greater than 3.0V. For the RN4870U, an RF antenna matching circuit must also be included as shown in [Figure 5-3](#).

**FIGURE 5-1: EXTERNAL PROGRAMMING HEADER CONFIGURATIONS**

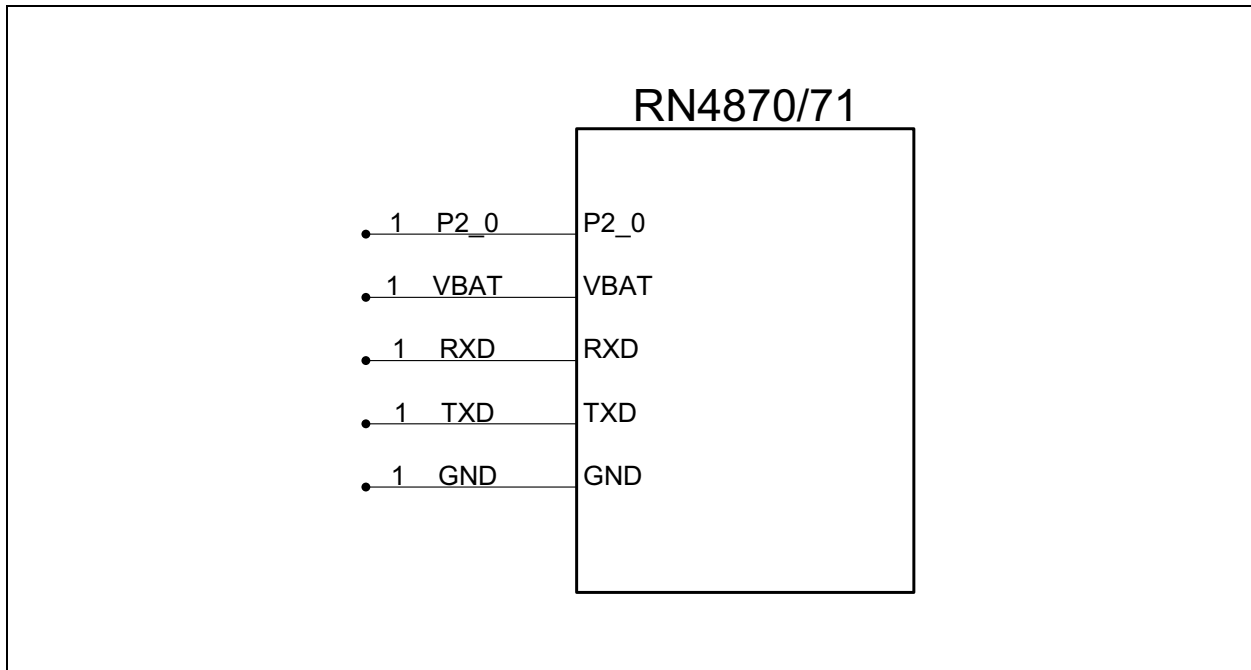
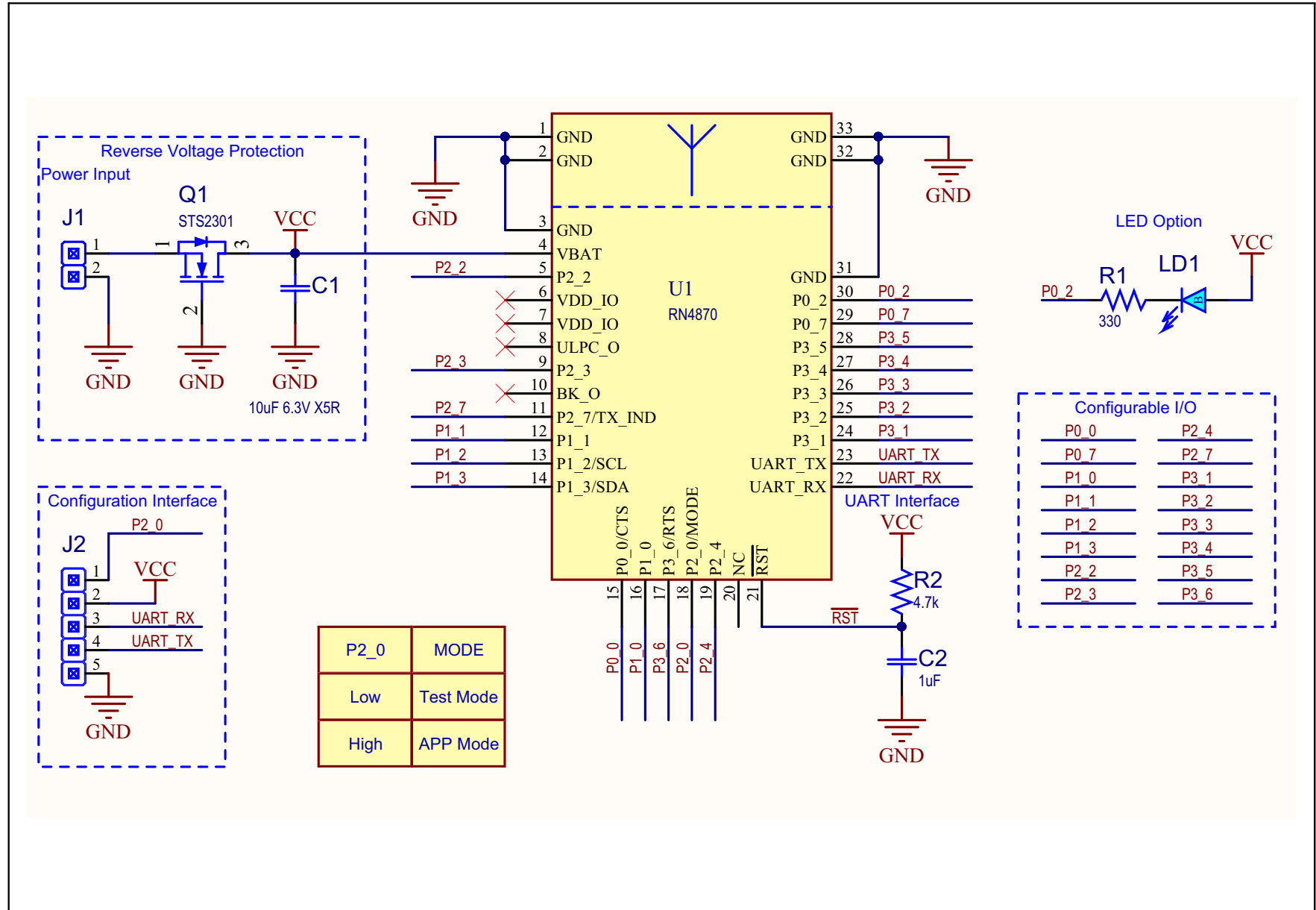

FIGURE 5-2: RN4870 REFERENCE CIRCUIT





**FIGURE 5-3: RN4870U REFERENCE CIRCUIT**

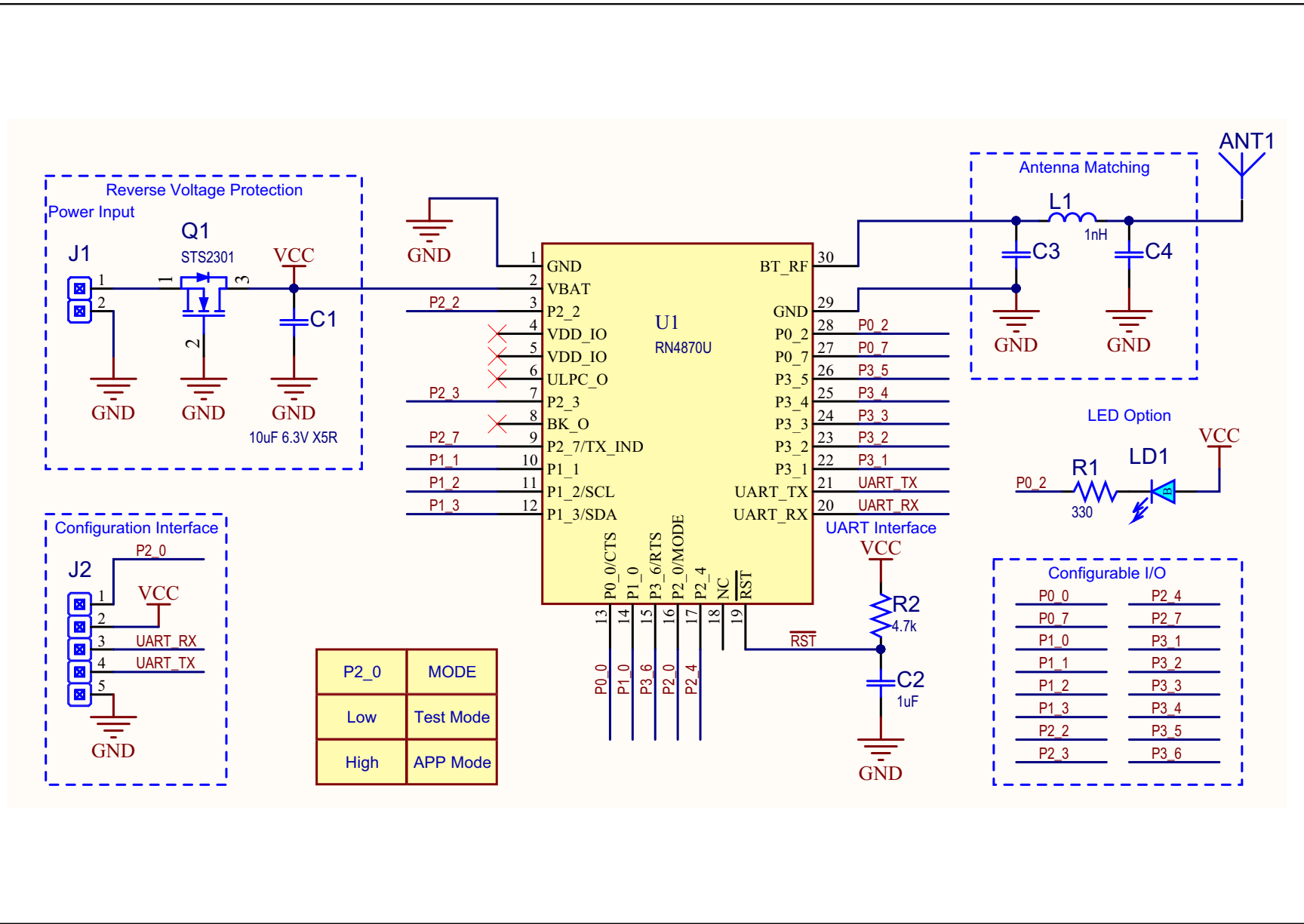
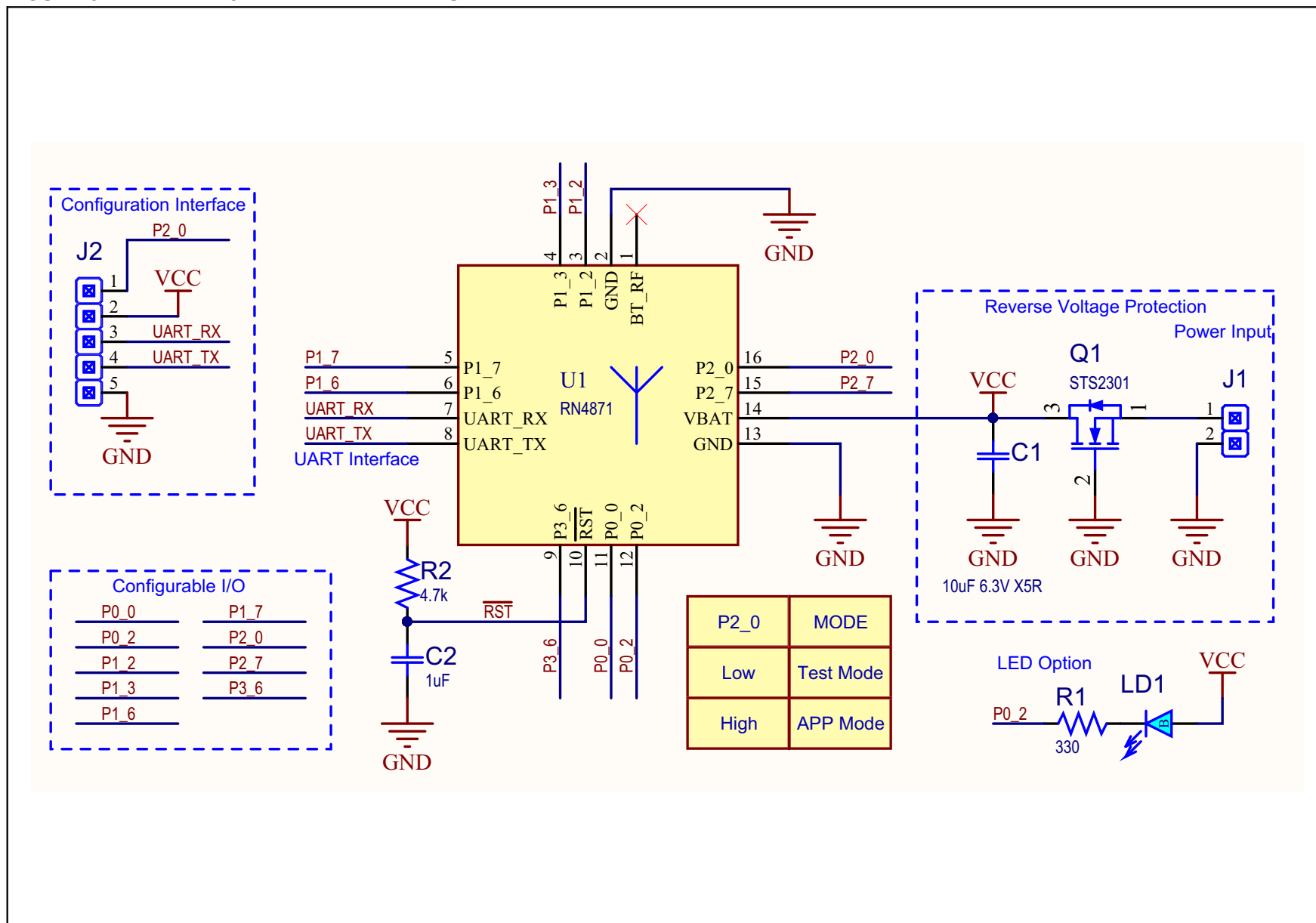
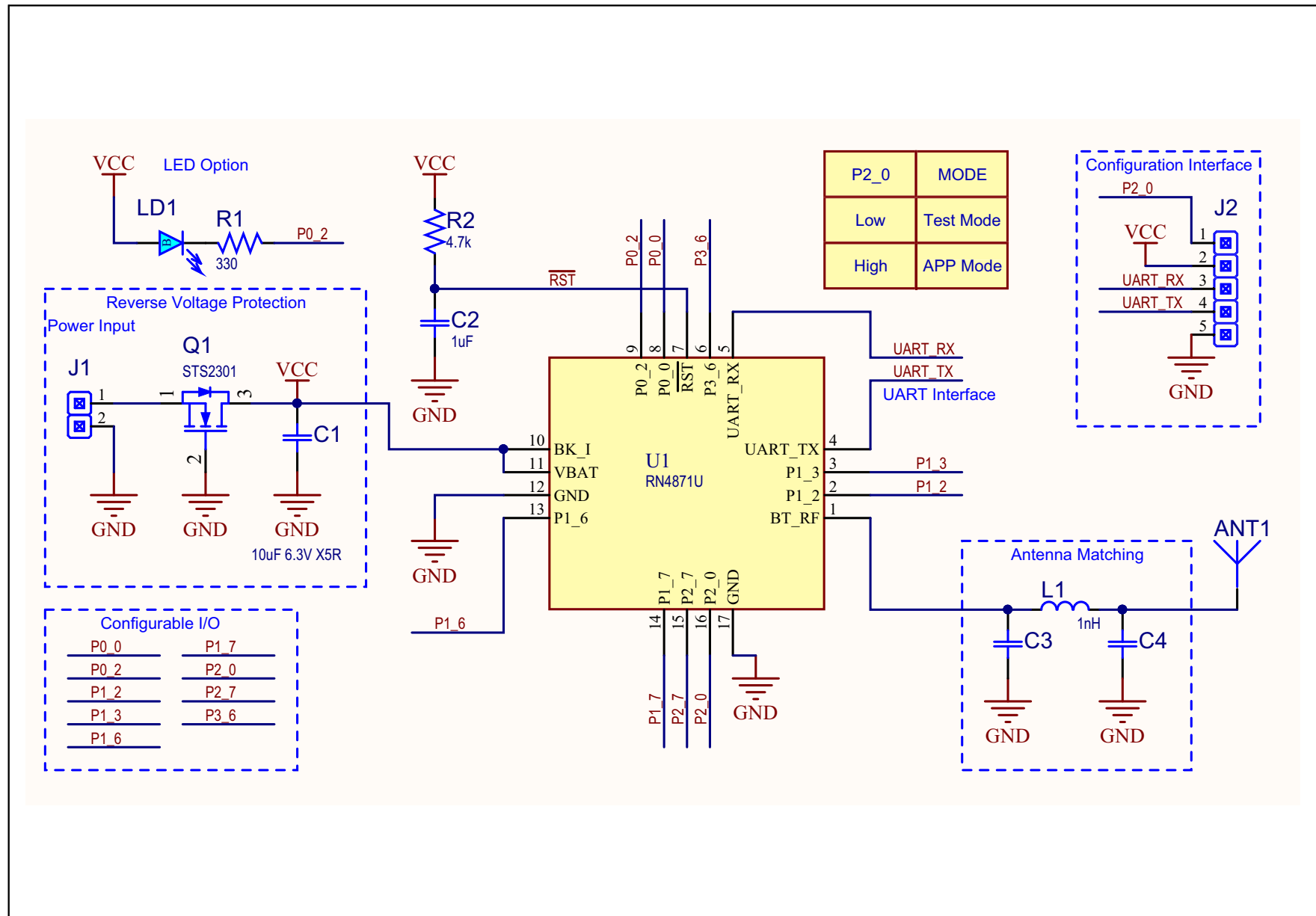

FIGURE 5-4: RN4871 REFERENCE CIRCUIT



**FIGURE 5-5: RN4871U REFERENCE CIRCUIT**



# RN4870/71

## 5.3 Power Drop Protection

To prevent any problems that may arise when the power supply goes below 1.9V, a power-supply drop-protection circuit is recommended. Essentially, this circuit consists of a Reset IC which acts as an *Open*

*Drain* with a Delay  $\leq 10$  ms, and is triggered at 1.8V power supply. [Figure 5-6](#) shows a recommended power drop protection circuit.

**FIGURE 5-6: POWER DROP PROTECTION CIRCUIT**

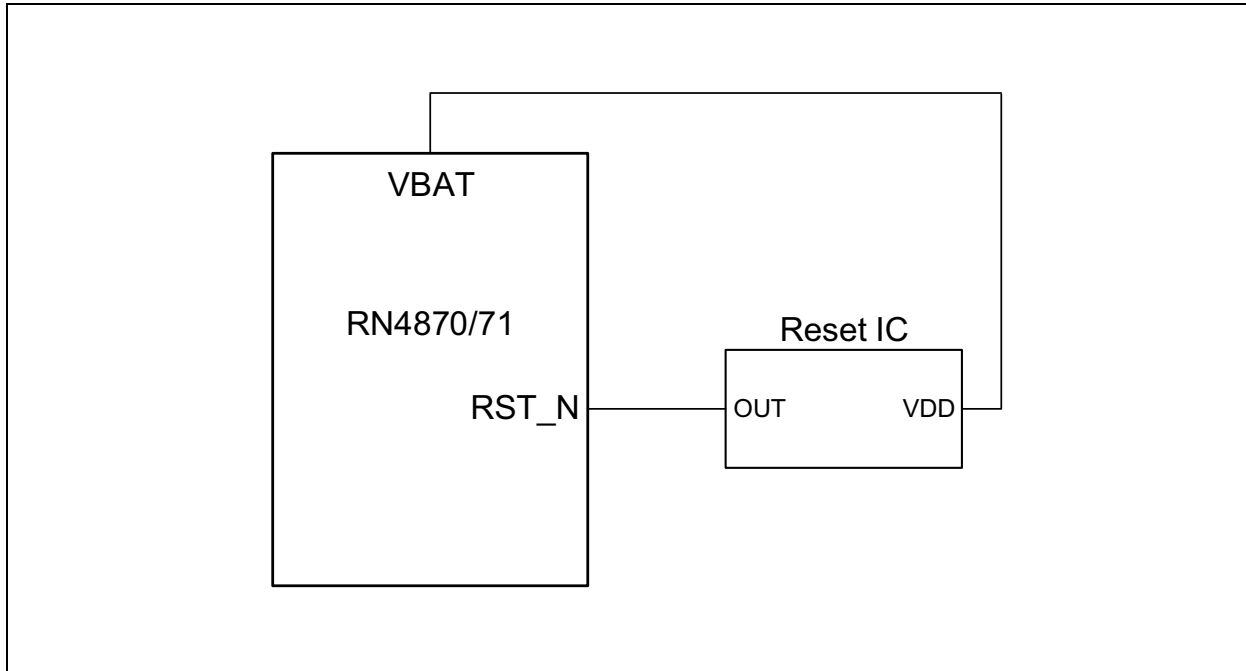

## 6.0 ASCII COMMAND API

The RN4870/71 command Application Programming Interfaces (APIs) are documented in the “RN4870/71 Bluetooth® Low Energy Module User’s Guide” (DS50002466A).

The following are the available command options and their categories:

- Connection
  - Establish connection
  - Disconnect
  - Bond/Unbond current connection
  - Start/Stop scan for other devices
  - Add/Delete peer devices to white list
  - Read RSSI values
  - Stop connection process
- I/O
  - Read/Write I<sup>2</sup>C
  - Change settings in the EEPROM
  - Configure pin functions
  - Configure GPIO mask
  - Set/Get GPIO states
  - Read and write analog data
  - PWM control
- System
  - Reboot
  - Factory default
  - Enter and Exit Command mode
  - Enter Low-Power mode
- Scripting
  - Enter Script mode
  - Declare event handler
  - Execute current script
  - List current script
  - Clear script
  - Define user function
- GATT Services
  - Create/Delete public services/characteristics
  - Read/Write characteristic values
  - Set notification for characteristics
- GAP Role
  - Central, Peripheral, Observer and Broadcaster
- Advertising
  - Start/Stop
  - Set custom advertisement content
  - Set scan response content
  - Set beacon content
- Private Service
  - Create/Delete private services/characteristics
  - Read/Write characteristic values
  - Set notification for characteristics
- Transparent UART
  - Enable/Disable
  - Peripheral side configuration
  - Central side configuration
- Remote configuration of the module
- Read individual device Information or Profile settings

# RN4870/71

---

NOTES:

## 7.0 SUPPORTED SERVICES

The RN4870 supports four built-in GATT services:

- Device Information public service
- Airpatch private service, which handles Over The Air (OTA) updates
- BeaconThings, which handles beacon services control
- UART Transparent private service, which handles data streaming function

In addition to the above predefined private services, the RN4870 provides the ability to create private services. If the services are supported on both end points of a Bluetooth Low Energy connection, such as Central and Peripheral devices, data can be exchanged. For example, two RN4870 modules can define a custom (private) service with its own unique characteristics. Data can be exchanged easily via Command API. Private services are *not* registered with the Bluetooth SIG, and therefore *not* interoperable with other Bluetooth Low Energy devices, unless the device implements the private service. An example of a built-in private service is the Transparent UART. For an example on how to create a custom service using the RN4870, refer to “*RN4870/71 Bluetooth® Low Energy Module User’s Guide*” (DS50002466A).

RN4870 allows custom defined services up to five public and four private services. Each custom defined service allows up to eight custom defined characteristics. All service definitions are saved in on-board Non-Volatile Memory (NVM) where the user must setup the module only once.

# RN4870/71

---

NOTES:



## 8.0 ANTENNA CHARACTERISTICS

The RN4870 and RN4871 modules contain an integral ceramic chip antenna. [Figure 8-1](#) and [Figure 8-2](#) show the antenna performance on the modules.

**FIGURE 8-1: RN4870 ANTENNA PERFORMANCE**

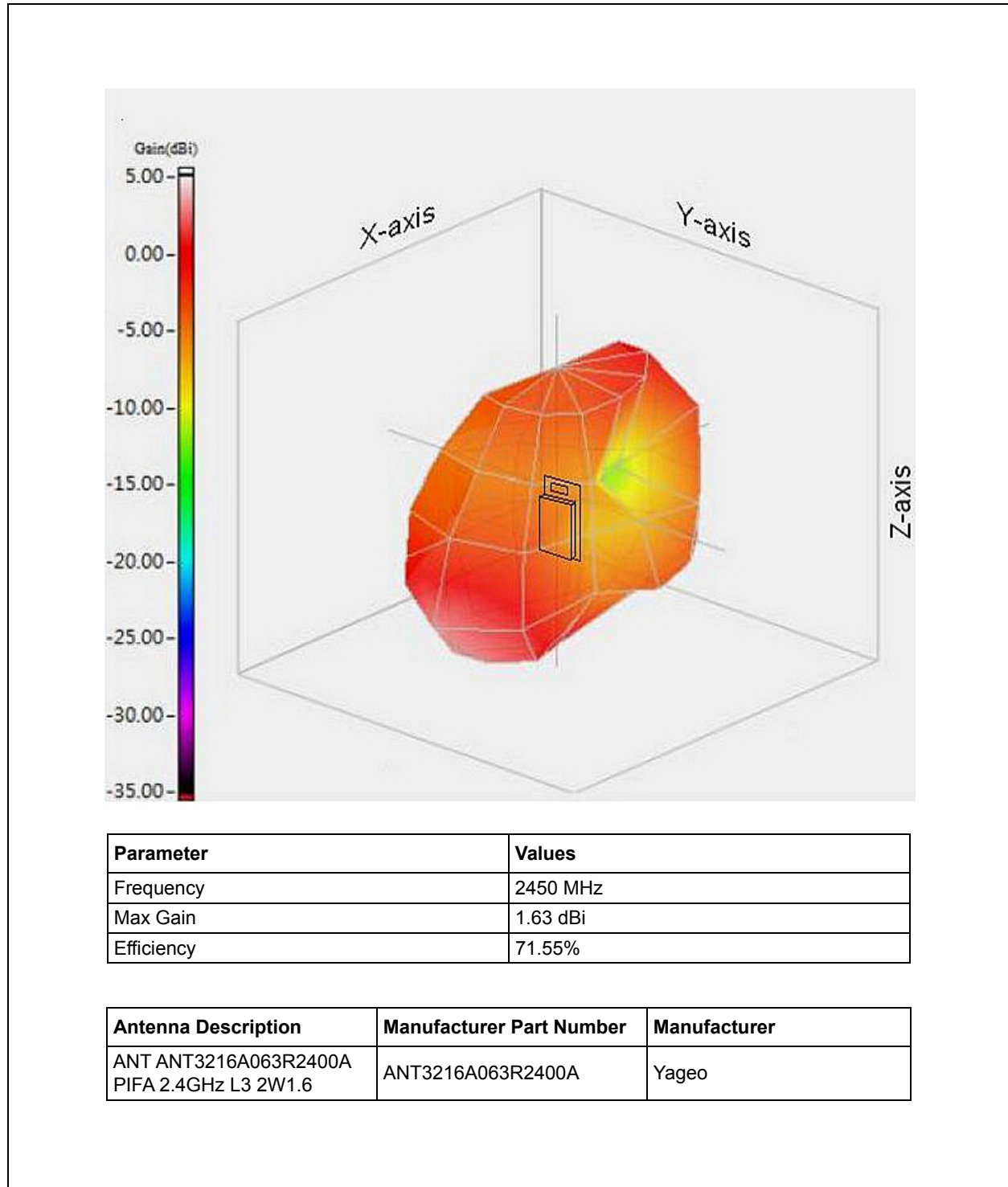

# RN4870/71

FIGURE 8-2: RN4871 ANTENNA PERFORMANCE

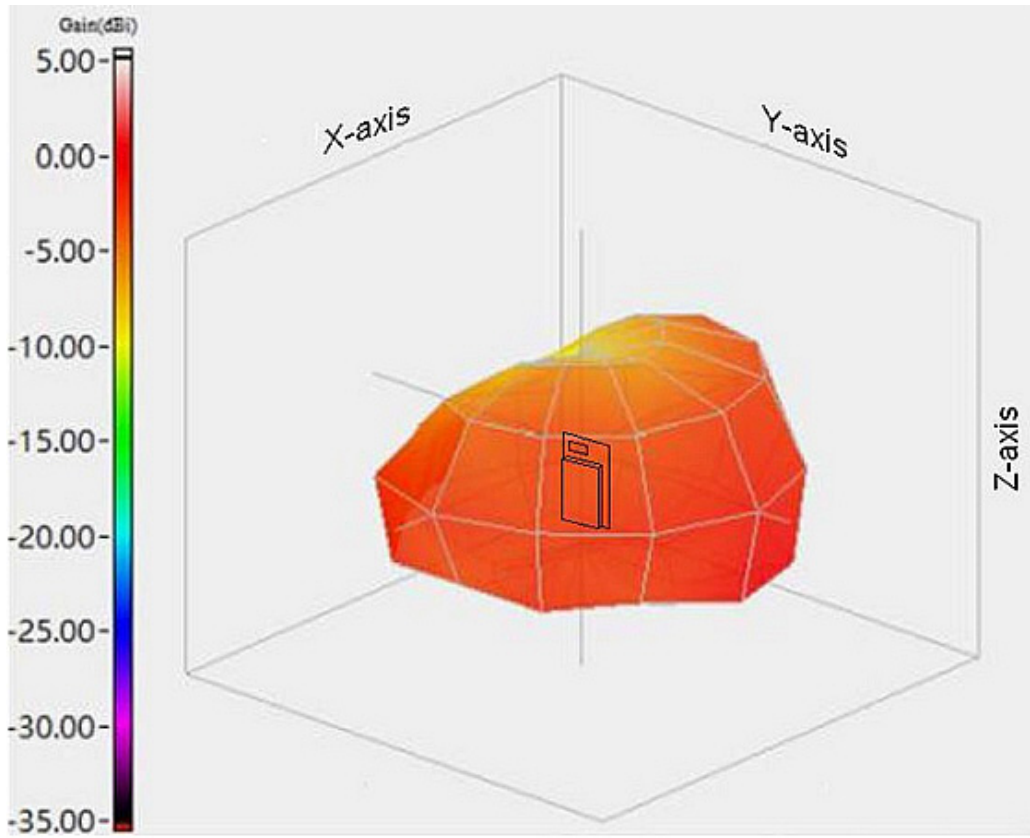

Parameter	Values
Frequency	2442 MHz
Max Gain	0.1 dBi
Efficiency	42.7%

Antenna Description	Manufacturer Part Number	Manufacturer
ANT AANT3216LL00R2400A PIFA 2.4GHz L3 2W1.6	ANT3216LL00R2400A	Yageo

## 9.0 TIMING CHARACTERISTICS

Figure 9-1 shows the timing diagram for the RN4870/71 modules when it is Reset in the Test mode and Application mode. Figure 9-2 shows the timing diagram for the module when it is powered on. In Application

mode, when RN4870/71 is ready to talk to MCU after Reset, the module provides a UART response indicating that the Reset is complete. For more details, refer to the “RN4870/71 Bluetooth® Low Energy Module User’s Guide” (DS50002466A).

**FIGURE 9-1: TIMING DIAGRAM OF RN4870/71 UART READY AFTER RESET (IN TEST AND APPLICATION MODE)**

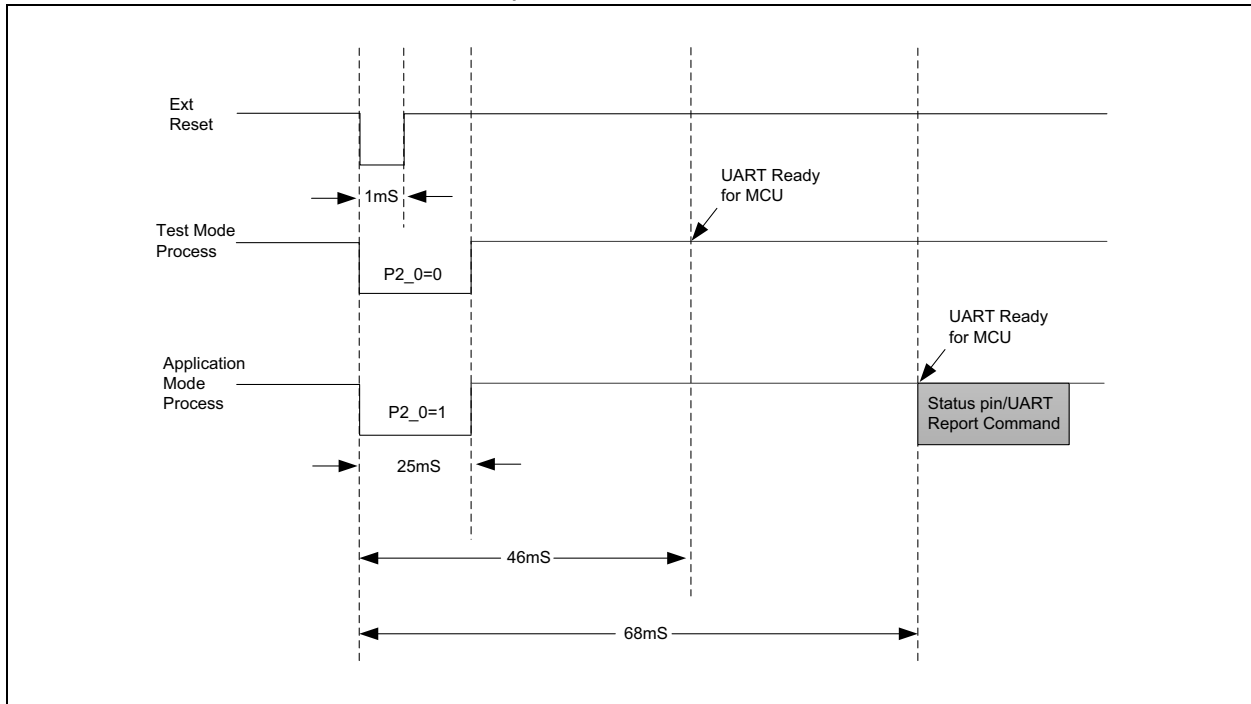

**FIGURE 9-2: TIMING DIAGRAM OF RN4870/71 UART WHEN POWERED ON (IN TEST AND APPLICATION MODE)**

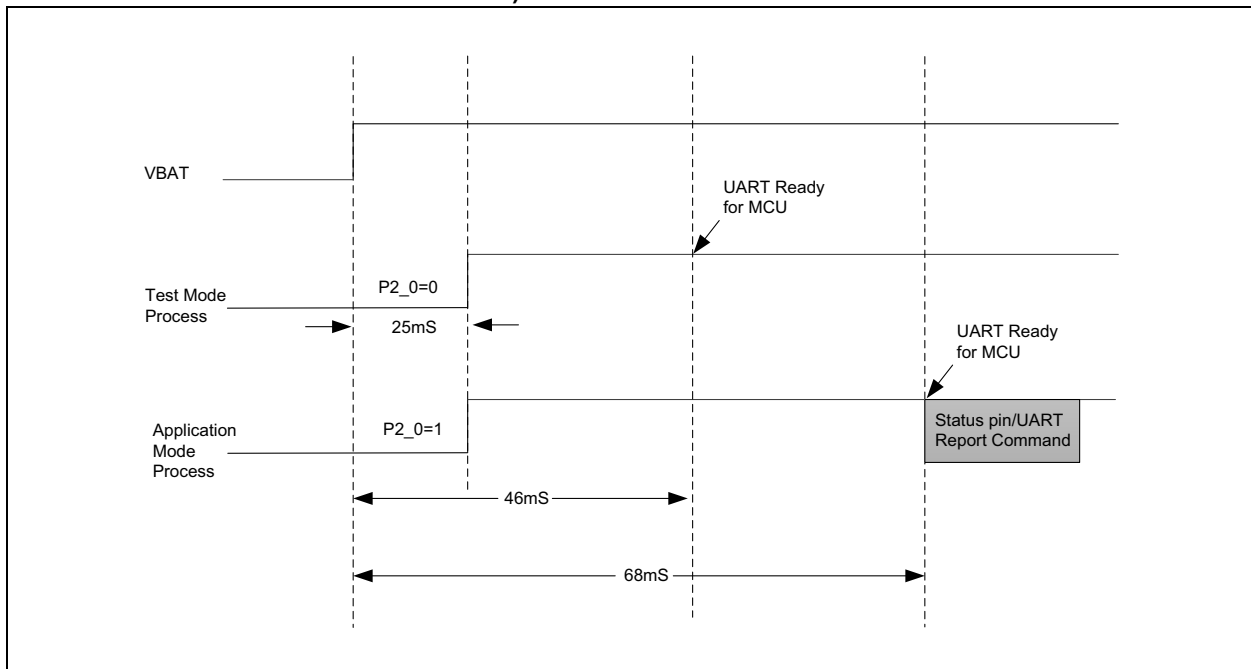

# RN4870/71

---

Table 9-1 shows the error rate for various UART baud rates for the RN4870/71 module. The system clock is running at 16 MHz.

**TABLE 9-1: ERROR RATE FOR VARIOUS BAUD RATES ON THE RN4870/71**

Set Baud Rate	Measured Baud Rate	Error
921600	941176	-2.12%
460800	457143	0.79%
307200	307692	-0.16%
230400	231884	-0.64%
115200	115942	-0.64%
57600	57971	-0.64%
38400	38095	0.79%
19200	19048	0.79%
9600	9524	0.79%

## 10.0 REGULATORY APPROVAL

This section outlines the regulatory information for the RN4870/71 module for the following countries:

- United States
- Canada
- Europe
- Japan
- Korea
- Taiwan
- Other Regulatory Jurisdictions

### 10.1 United States

The RN4870/71 module has received Federal Communications Commission (FCC) CFR47 Telecommunications, Part 15 Subpart C “Intentional Radiators” single-modular approval in accordance with Part 15.212 Modular Transmitter approval. Single-modular transmitter approval is defined as a complete RF transmission sub-assembly, designed to be incorporated into another device, that must demonstrate compliance with FCC rules and policies independent of any host. A transmitter with a modular grant can be installed in different end-use products (referred to as a host, host product, or host device) by the grantee or other equipment manufacturer, then the host product may not require additional testing or equipment authorization for the transmitter function provided by that specific module or limited module device.

A host product itself is required to comply with all other applicable FCC equipment authorization regulations, requirements, and equipment functions that are not associated with the transmitter module portion. For example, compliance must be demonstrated: to regulations for other transmitter components within a host product; to requirements for unintentional radiators (Part 15 Subpart B), such as digital devices, computer peripherals, radio receivers, etc.; and to additional authorization requirements for the non-transmitter functions on the transmitter module (i.e., Verification or Declaration of Conformity) as appropriate (e.g., Bluetooth and Wi-Fi transmitter modules may also contain digital logic functions).

#### 10.1.1 LABELING AND USER INFORMATION REQUIREMENTS

The RN4870 module has been labeled with its own FCC ID number, and if the FCC ID is not visible when the module is installed inside another device, then the outside of the finished product into which the module is installed must also display a label referring to the enclosed module. This exterior label can use wording as follows:

For the RN4870 module:

Contains Transmitter Module  
FCC ID: A8TBM70ABCDEF GH  
*or*  
Contains FCC ID: A8TBM70ABCDEF GH

This device complies with Part 15 of the FCC Rules. Operation is subject to the following two conditions: (1) this device may not cause harmful interference, and (2) this device must accept any interference received, including interference that may cause undesired operation.

Due to the limited size of the RN4871, the FCC Identifier (FCC ID) is not displayed on the module. Therefore, the FCC ID must be placed on the outside of the finished product into which the module is installed must also display a label referring to the enclosed module. This exterior label can use wording as follows:

For the RN4871 module:

Contains Transmitter Module  
FCC ID: A8TBM71S2  
*or*  
Contains FCC ID: A8TBM71S2

This device complies with Part 15 of the FCC Rules. Operation is subject to the following two conditions: (1) this device may not cause harmful interference, and (2) this device must accept any interference received, including interference that may cause undesired operation.

# RN4870/71

A user's manual for the product should include the following statement:

This equipment has been tested and found to comply with the limits for a Class B digital device, pursuant to part 15 of the FCC Rules. These limits are designed to provide reasonable protection against harmful interference in a residential installation. This equipment generates, uses and can radiate radio frequency energy, and if not installed and used in accordance with the instructions, may cause harmful interference to radio communications. However, there is no guarantee that interference will not occur in a particular installation. If this equipment does cause harmful interference to radio or television reception, which can be determined by turning the equipment off and on, the user is encouraged to try to correct the interference by one or more of the following measures:

- Reorient or relocate the receiving antenna.
- Increase the separation between the equipment and receiver.
- Connect the equipment into an outlet on a circuit different from that to which the receiver is connected.
- Consult the dealer or an experienced radio/TV technician for help.

Additional information on labeling and user information requirements for Part 15 devices can be found in KDB Publication 784748 available at the FCC Office of Engineering and Technology (OET) Laboratory Division Knowledge Database (KDB)  
<http://apps.fcc.gov/oetcf/kdb/index.cfm>.

## 10.1.2 RF EXPOSURE

All transmitters regulated by FCC must comply with RF exposure requirements. KDB Publication 447498 General RF Exposure Guidance provides guidance in determining whether proposed or existing transmitting facilities, operations or devices comply with limits for human exposure to Radio Frequency (RF) fields adopted by the Federal Communications Commission (FCC).

Output power listed is conducted. This grant is valid only when the module is sold to OEM integrators and must be installed by the OEM or OEM integrators. This transmitter is restricted for use with the specific antenna(s) tested in this application for Certification and must not be co-located or operating in conjunction with any other antenna or transmitters within a host device, except in accordance with FCC multi-transmitter product procedures. This module is approved for installation into mobile or/and portable host platforms.

## 10.1.3 HELPFUL WEB SITES

Federal Communications Commission (FCC):  
<http://www.fcc.gov>

FCC Office of Engineering and Technology (OET) Laboratory Division Knowledge Database (KDB):  
<http://apps.fcc.gov/oetcf/kdb/index.cfm>

## 10.2 Canada

The RN4870/71 module has been certified for use in Canada under Industry Canada (IC) Radio Standards Procedure (RSP) RSP-100, Radio Standards Specification (RSS) RSS-Gen, RSS-210, and RSS-247. Modular approval permits the installation of a module in a host device without the need to recertify the device.

### 10.2.1 LABELING AND USER INFORMATION REQUIREMENTS

Labeling Requirements (from RSP-100 - Issue 10, Section 3): The host device shall be properly labeled to identify the module within the host device.

Modular Devices (from RSP-100 - Issue 10, Section 7): The Industry Canada certification label of a module shall be clearly visible at all times when installed in the host device, otherwise the host device must be labeled to display the Industry Canada certification number of the module, preceded by the words "Contains transmitter module", or the word "Contains", or similar wording expressing the same meaning, as follows:

For the RN4870 module:

Contains transmitter module  
IC: 12246A-BM70BLES1F2

Due to the limited size of the RN4871, the Industry Canada certification number is not displayed on the module. Therefore, the host device must be labeled to display the Industry Canada certification number of the module, preceded by the words "Contains transmitter module", or the word "Contains", or similar wording expressing the same meaning, as follows:

Contains transmitter module  
IC: 12246A-BM71S2

User Manual Notice for License-Exempt Radio Apparatus (from Section 8.4, RSS-Gen, Issue 4, November 2014): User manuals for license-exempt radio apparatus shall contain the following or equivalent notice in a conspicuous location in the user manual or alternatively on the device or both:

This device complies with Industry Canada's license-exempt RSSs. Operation is subject to the following two conditions:

- (1) This device may not cause interference; and
- (2) This device must accept any interference, including interference that may cause undesired operation of the device.

Le présent appareil est conforme aux CNR d'Industrie Canada applicables aux appareils radio exempts de licence. L'exploitation est autorisée aux deux conditions suivantes:

- (1) l'appareil ne doit pas produire de brouillage;
- (2) l'utilisateur de l'appareil doit accepter tout brouillage radioélectrique subi, même si le brouillage est susceptible d'en compromettre le fonctionnement.

## 10.2.2 RF EXPOSURE

All transmitters regulated by IC must comply with RF exposure requirements listed in RSS-102 - Radio Frequency (RF) Exposure Compliance of Radiocommunication Apparatus (All Frequency Bands).

## 10.2.3 HELPFUL WEB SITES

Industry Canada: <http://www.ic.gc.ca/>

## 10.3 Europe

The RN4870/71 module is an R&TTE Directive assessed radio module that is CE marked and has been manufactured and tested with the intention of being integrated into a final product.

The RN4870/71 module has been tested to R&TTE Directive 1999/5/EC Essential Requirements for Health and Safety (Article (3.1(a)), Electromagnetic Compatibility (EMC) (Article 3.1(b)), and Radio (Article 3.2) and are summarized in [Table 10-1](#) and [Table 10-2](#) European Compliance Testing. A Notified Body Opinion has also been issued. All test reports are available on the RN4870/71 product web page at <http://www.microchip.com>.

The R&TTE Compliance Association provides guidance on modular devices in document **Technical Guidance Note 01** available at [http://www.rteca.com/html/download\\_area.htm](http://www.rteca.com/html/download_area.htm).

**Note:** To maintain conformance to the testing listed in [Table 10-1](#), the module shall be installed in accordance with the installation instructions in this data sheet and shall not be modified.

When integrating a radio module into a completed product the integrator becomes the manufacturer of the final product and is therefore responsible for demonstrating compliance of the final product with the essential requirements of the R&TTE Directive.

### 10.3.1 LABELING AND USER INFORMATION REQUIREMENTS

The label on the final product which contains the RN4870/71 module must follow CE marking requirements. The R&TTE Compliance Association **Technical Guidance Note 01** provides guidance on final product CE marking.

# RN4870/71

## 10.3.2 HELPFUL WEB SITES

A document that can be used as a starting point in understanding the use of Short Range Devices (SRD) in Europe is the European Radio Communications Committee (ERC) Recommendation 70-03 E, which can be downloaded from the European Radio Communications Office (ERO) at: <http://www.ero.dk/>.

Additional helpful web sites are:

- Radio and Telecommunications Terminal Equipment (R&TTE):  
[http://ec.europa.eu/enterprise/rtte/index\\_en.htm](http://ec.europa.eu/enterprise/rtte/index_en.htm)

- European Conference of Postal and Telecommunications Administrations (CEPT):  
<http://www.cept.org/>
- European Telecommunications Standards Institute (ETSI):  
<http://www.etsi.org>
- European Radio Communications Office (ERO):  
<http://www.ero.dk/>
- The Radio and Telecommunications Terminal Equipment Compliance Association (R&TTE CA):  
<http://www.rteca.com/>

**TABLE 10-1: EUROPEAN COMPLIANCE TESTING FOR RN4870**

Certification	Standards	Article	Laboratory	Report Number
Safety	EN60950-1:2006/A11:2009/A1:2010/ A12:2011/A2:2013	(3.1(a))	TUV Rheinland	10051261 003
Health	EN 62479:2010	(3.1(b))		10053580 001
EMC	EN 301 489-1 V1.9.2			10051137 002
	EN 301 489-17 V2.2.1			
Radio	EN 300 328 V1.9.1	(3.2)		10053580 001
Notified Body Opinion	<b>CE0197</b>			10048935 001

**TABLE 10-2: EUROPEAN COMPLIANCE TESTING FOR RN4871**

Certification	Standards	Article	Laboratory	Report Number
Safety	EN60950-1:2006/A11:2009/A1:2010/ A12:2011/A2:2013	(3.1(a))	TUV Rheinland	10053210 001
Health	EN 62479:2010	(3.1(b))		10053433 001
EMC	EN 301 489-1 V1.9.2			10052964 001
	EN 301 489-17 V2.2.1			
Radio	EN 300 328 V1.9.1	(3.2)		10053433 001
Notified Body Opinion	<b>CE0197</b>			10048936 001



## 10.4 Japan

The RN4870/71 module has received type certification and is labeled with its own technical conformity mark and certification number as required to conform to the technical standards regulated by the Ministry of Internal Affairs and Communications (MIC) of Japan pursuant to the Radio Act of Japan.

Integration of this module into a final product does not require additional radio certification provided installation instructions are followed and no modifications of the module are allowed. Additional testing may be required:

- If the host product is subject to electrical appliance safety (for example, powered from an AC mains), the host product may require Product Safety Electrical Appliance and Material (PSE) testing. The integrator should contact their conformance laboratory to determine if this testing is required.
- There is a voluntary Electromagnetic Compatibility (EMC) test for the host product administered by VCCI: [http://www.vcci.jp/vcci\\_e/index.html](http://www.vcci.jp/vcci_e/index.html)

### 10.4.1 LABELING AND USER INFORMATION REQUIREMENTS

The label on the final product which contains the RN4870/71 module must follow Japan marking requirements. The integrator of the module should refer to the labeling requirements for Japan available at the Ministry of Internal Affairs and Communications (MIC) website.

The RN4870 module is labeled with its own technical conformity mark and certification number. The final product in which this module is being used must have a label referring to the type certified module inside:

Contains transmitter module with certificate number:



Due to the limited size of the RN4871, the technical conformity mark and certification number is not displayed on the module. Therefore, the final product in which this module is being used must have a label referring to the type certified module inside:

Contains transmitter module with certificate number:



### 10.4.2 HELPFUL WEB SITES

Ministry of Internal Affairs and Communications (MIC): <http://www.tele.soumu.go.jp/e/index.htm>

Association of Radio Industries and Businesses (ARIB): <http://www.arib.or.jp/english/>

## 10.5 Korea

The RN4870/71 module has received certification of conformity in accordance with the Radio Waves Act. Integration of this module into a final product does not require additional radio certification provided installation instructions are followed and no modifications of the module are allowed.

### 10.5.1 LABELING AND USER INFORMATION REQUIREMENTS

The label on the final product which contains the RN4870/71 module must follow KC marking requirements. The integrator of the module should refer to the labeling requirements for Korea available on the Korea Communications Commission (KCC) website.

The RN4870 module is labeled with its own KC mark. The final product requires the KC mark and certificate number of the module:

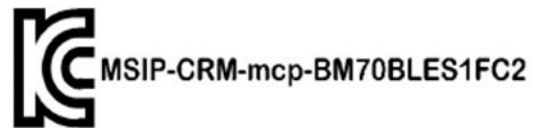

Due to the limited size of the RN4871, the KC mark is not displayed on the module. Therefore, final product requires the KC mark and certificate number of the module:

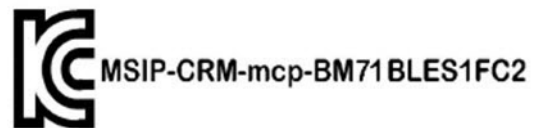

### 10.5.2 HELPFUL WEB SITES

Korea Communications Commission (KCC): <http://www.kcc.go.kr>

National Radio Research Agency (RRA): <http://rra.go.kr>

# RN4870/71

---

## 10.6 Taiwan

The RN4870/71 module has received compliance approval in accordance with the Telecommunications Act. Customers seeking to use the compliance approval in their product should contact Microchip Technology sales or distribution partners to obtain a Letter of Authority.

Integration of this module into a final product does not require additional radio certification provided installation instructions are followed and no modifications of the module are allowed.

### 10.6.1 LABELING AND USER INFORMATION REQUIREMENTS

The RN4870 module is labeled with its own NCC ID number, and if the NCC ID is not visible when the module is installed inside another device, then the outside of the device must also display a label referring to the enclosed module. This exterior label can use wording such as the following:



Due to the limited size of the RN4871, the NCC ID is not displayed on the module. Therefore, the outside of the device must also display a label referring to the enclosed module. This exterior label can use wording such as the following:

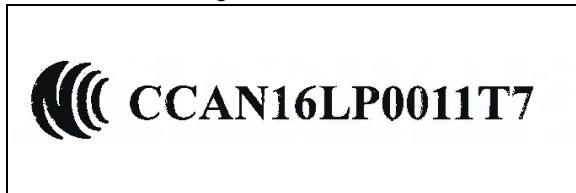

The user's manual should contain below warning (for RF device) in traditional Chinese:

注意！

依據 低功率電波輻射性電機管理辦法

第十二條 經型式認證合格之低功率射頻電機，

非經許可，

公司、商號或使用者均不得擅自變更頻率、加大功率或變更原設計

之特性及功能。

第十四條 低功率射頻電機之使用不得影響飛航安全及干擾合法通信；

經發現有干擾現象時，應立即停用，並改善至無干擾時方得繼續使用。

前項合法通信，指依電信規定作業之無線電信。

低功率射頻電機須忍受合法通信或工業、科學及醫療用電波輻射性

電機設備之干擾。

### 10.6.2 HELPFUL WEB SITES

National Communications Commission (NCC):

<http://www.ncc.gov.tw>.

## 10.7 Other Regulatory Jurisdictions

Should other regulatory jurisdiction certification be required by the customer, or the customer need to recertify the module for other reasons, a certification utility is available. For further regulatory Certification Utility and documentation, contact your local Microchip Technology sales office.

## 11.0 ORDERING INFORMATION

Table 11-1 provides ordering information for the RN4870/71 module.

**TABLE 11-1: ORDERING INFORMATION**

Part Number	Description
RN4870-V/RM118	Bluetooth 4.2 BLE Single mode, Class 2, Surface mount module with antenna and shield. Size: 12 mm x 22 mm
RN4870U-V/RM118	Bluetooth 4.2 BLE Single mode, Class 2, Surface mount module, external antenna, no shield. Size: 12 mm x15 mm
RN4871-V/RM118	Bluetooth 4.2 BLE Single mode, Class 2, Surface mount module with antenna and shield. Size: 9 mm x 11.5 mm
RN4871U-V/RM118	Bluetooth 4.2 BLE Single mode, Class 2, Surface mount module, external antenna, no shield. Size: 6 mm x 8 mm

Go to <http://www.microchip.com> for current pricing and a list of distributors carrying Microchip products.

## APPENDIX A: REVISION HISTORY

### Revision A (April 2016)

This is the initial release of this document.

## THE MICROCHIP WEB SITE

Microchip provides online support via our WWW site at [www.microchip.com](http://www.microchip.com). This web site is used as a means to make files and information easily available to customers. Accessible by using your favorite Internet browser, the web site contains the following information:

- **Product Support** – Data sheets and errata, application notes and sample programs, design resources, user's guides and hardware support documents, latest software releases and archived software
- **General Technical Support** – Frequently Asked Questions (FAQ), technical support requests, online discussion groups, Microchip consultant program member listing
- **Business of Microchip** – Product selector and ordering guides, latest Microchip press releases, listing of seminars and events, listings of Microchip sales offices, distributors and factory representatives

## CUSTOMER CHANGE NOTIFICATION SERVICE

Microchip's customer notification service helps keep customers current on Microchip products. Subscribers will receive e-mail notification whenever there are changes, updates, revisions or errata related to a specified product family or development tool of interest.

To register, access the Microchip web site at [www.microchip.com](http://www.microchip.com). Under "Support", click on "Customer Change Notification" and follow the registration instructions.

## CUSTOMER SUPPORT

Users of Microchip products can receive assistance through several channels:

- Distributor or Representative
- Local Sales Office
- Field Application Engineer (FAE)
- Technical Support

Customers should contact their distributor, representative or Field Application Engineer (FAE) for support. Local sales offices are also available to help customers. A listing of sales offices and locations is included in the back of this document.

**Technical support is available through the web site at: <http://microchip.com/support>**

# RN4870/71

## PRODUCT IDENTIFICATION SYSTEM

To order or obtain information, for example, on pricing or delivery, refer to the factory or the listed sales office.

<u>PART NO.</u>	<u>V</u>	<u>RM</u>	<u>XXX</u>	<b>Example:</b>
Device	Temperature Range	Package	Firmware Revision Number	RN4870-V/RM118: Various temperature
<b>Device:</b>	RN4870: Ceramic Chip Antenna RN4870U: External Antenna RN4871: Ceramic Chip Antenna RN4871U: External Antenna			<b>Note 1:</b> Tape and Reel identifier only appears in the catalog part number description. This identifier is used for ordering purposes and is <i>not</i> printed on the device package. Check with your Microchip Sales Office for package availability with the Tape and Reel option.
<b>Temperature Range:</b>	V = -20°C to +70°C (Various)			
<b>Package:</b>	RM = Radio Module			

---

---

**Note the following details of the code protection feature on Microchip devices:**

- Microchip products meet the specification contained in their particular Microchip Data Sheet.
- Microchip believes that its family of products is one of the most secure families of its kind on the market today, when used in the intended manner and under normal conditions.
- There are dishonest and possibly illegal methods used to breach the code protection feature. All of these methods, to our knowledge, require using the Microchip products in a manner outside the operating specifications contained in Microchip's Data Sheets. Most likely, the person doing so is engaged in theft of intellectual property.
- Microchip is willing to work with the customer who is concerned about the integrity of their code.
- Neither Microchip nor any other semiconductor manufacturer can guarantee the security of their code. Code protection does not mean that we are guaranteeing the product as “unbreakable.”

Code protection is constantly evolving. We at Microchip are committed to continuously improving the code protection features of our products. Attempts to break Microchip's code protection feature may be a violation of the Digital Millennium Copyright Act. If such acts allow unauthorized access to your software or other copyrighted work, you may have a right to sue for relief under that Act.

---

Information contained in this publication regarding device applications and the like is provided only for your convenience and may be superseded by updates. It is your responsibility to ensure that your application meets with your specifications. MICROCHIP MAKES NO REPRESENTATIONS OR WARRANTIES OF ANY KIND WHETHER EXPRESS OR IMPLIED, WRITTEN OR ORAL, STATUTORY OR OTHERWISE, RELATED TO THE INFORMATION, INCLUDING BUT NOT LIMITED TO ITS CONDITION, QUALITY, PERFORMANCE, MERCHANTABILITY OR FITNESS FOR PURPOSE. Microchip disclaims all liability arising from this information and its use. Use of Microchip devices in life support and/or safety applications is entirely at the buyer's risk, and the buyer agrees to defend, indemnify and hold harmless Microchip from any and all damages, claims, suits, or expenses resulting from such use. No licenses are conveyed, implicitly or otherwise, under any Microchip intellectual property rights unless otherwise stated.

*Microchip received ISO/TS-16949:2009 certification for its worldwide headquarters, design and wafer fabrication facilities in Chandler and Tempe, Arizona; Gresham, Oregon and design centers in California and India. The Company's quality system processes and procedures are for its PIC® MCUs and dsPIC® DSCs, KEELOQ® code hopping devices, Serial EEPROMs, microperipherals, nonvolatile memory and analog products. In addition, Microchip's quality system for the design and manufacture of development systems is ISO 9001:2000 certified.*

**QUALITY MANAGEMENT SYSTEM  
CERTIFIED BY DNV  
= ISO/TS 16949 =**

### Trademarks

The Microchip name and logo, the Microchip logo, AnyRate, dsPIC, FlashFlex, flexPWR, Heldo, JukeBlox, KeeLoq, KeeLoq logo, Klear, LANCheck, LINK MD, MediaLB, MOST, MOST logo, MPLAB, OptoLyzer, PIC, PICSTART, PIC32 logo, RightTouch, SpyNIC, SST, SST Logo, SuperFlash and UNI/O are registered trademarks of Microchip Technology Incorporated in the U.S.A. and other countries.

ClockWorks, The Embedded Control Solutions Company, ETHERSYNCH, Hyper Speed Control, HyperLight Load, IntellIMOS, mTouch, Precision Edge, and QUIET-WIRE are registered trademarks of Microchip Technology Incorporated in the U.S.A.

Analog-for-the-Digital Age, Any Capacitor, AnyIn, AnyOut, BodyCom, chipKIT, chipKIT logo, CodeGuard, dsPICDEM, dsPICDEM.net, Dynamic Average Matching, DAM, ECAN, EtherGREEN, In-Circuit Serial Programming, ICSP, Inter-Chip Connectivity, JitterBlocker, KlearNet, KlearNet logo, MiWi, motorBench, MPASM, MPF, MPLAB Certified logo, MPLIB, MPLINK, MultiTRAK, NetDetach, Omniscient Code Generation, PICDEM, PICDEM.net, PICkit, PICtail, PureSilicon, RightTouch logo, REAL ICE, Ripple Blocker, Serial Quad I/O, SQL, SuperSwitcher, SuperSwitcher II, Total Endurance, TSHARC, USBCheck, VariSense, ViewSpan, WiperLock, Wireless DNA, and ZENA are trademarks of Microchip Technology Incorporated in the U.S.A. and other countries.

SQTP is a service mark of Microchip Technology Incorporated in the U.S.A.

Silicon Storage Technology is a registered trademark of Microchip Technology Inc. in other countries.

GestIC is a registered trademarks of Microchip Technology Germany II GmbH & Co. KG, a subsidiary of Microchip Technology Inc., in other countries.

All other trademarks mentioned herein are property of their respective companies.

© 2016, Microchip Technology Incorporated, Printed in the U.S.A., All Rights Reserved.

ISBN: 978-1-5224-0514-6



# MICROCHIP

## Worldwide Sales and Service

### AMERICAS

**Corporate Office**  
2355 West Chandler Blvd.  
Chandler, AZ 85224-6199  
Tel: 480-792-7200  
Fax: 480-792-7277  
Technical Support:  
<http://www.microchip.com/support>  
Web Address:  
[www.microchip.com](http://www.microchip.com)

**Atlanta**  
Duluth, GA  
Tel: 678-957-9614  
Fax: 678-957-1455

**Austin, TX**  
Tel: 512-257-3370

**Boston**  
Westborough, MA  
Tel: 774-760-0087  
Fax: 774-760-0088

**Chicago**  
Itasca, IL  
Tel: 630-285-0071  
Fax: 630-285-0075

**Cleveland**  
Independence, OH  
Tel: 216-447-0464  
Fax: 216-447-0643

**Dallas**  
Addison, TX  
Tel: 972-818-7423  
Fax: 972-818-2924

**Detroit**  
Novi, MI  
Tel: 248-848-4000

**Houston, TX**  
Tel: 281-894-5983

**Indianapolis**  
Noblesville, IN  
Tel: 317-773-8323  
Fax: 317-773-5453

**Los Angeles**  
Mission Viejo, CA  
Tel: 949-462-9523  
Fax: 949-462-9608

**New York, NY**  
Tel: 631-435-6000

**San Jose, CA**  
Tel: 408-735-9110

**Canada - Toronto**  
Tel: 905-673-0699  
Fax: 905-673-6509

### ASIA/PACIFIC

**Asia Pacific Office**  
Suites 3707-14, 37th Floor  
Tower 6, The Gateway  
Harbour City, Kowloon

**Hong Kong**  
Tel: 852-2943-5100  
Fax: 852-2401-3431

**Australia - Sydney**  
Tel: 61-2-9868-6733  
Fax: 61-2-9868-6755

**China - Beijing**  
Tel: 86-10-8569-7000  
Fax: 86-10-8528-2104

**China - Chengdu**  
Tel: 86-28-8665-5511  
Fax: 86-28-8665-7889

**China - Chongqing**  
Tel: 86-23-8980-9588  
Fax: 86-23-8980-9500

**China - Dongguan**  
Tel: 86-769-8702-9880

**China - Hangzhou**  
Tel: 86-571-8792-8115  
Fax: 86-571-8792-8116

**China - Hong Kong SAR**  
Tel: 852-2943-5100  
Fax: 852-2401-3431

**China - Nanjing**  
Tel: 86-25-8473-2460  
Fax: 86-25-8473-2470

**China - Qingdao**  
Tel: 86-532-8502-7355  
Fax: 86-532-8502-7205

**China - Shanghai**  
Tel: 86-21-5407-5533  
Fax: 86-21-5407-5066

**China - Shenyang**  
Tel: 86-24-2334-2829  
Fax: 86-24-2334-2393

**China - Shenzhen**  
Tel: 86-755-8864-2200  
Fax: 86-755-8203-1760

**China - Wuhan**  
Tel: 86-27-5980-5300  
Fax: 86-27-5980-5118

**China - Xian**  
Tel: 86-29-8833-7252  
Fax: 86-29-8833-7256

### ASIA/PACIFIC

**China - Xiamen**  
Tel: 86-592-2388138  
Fax: 86-592-2388130

**China - Zhuhai**  
Tel: 86-756-3210040  
Fax: 86-756-3210049

**India - Bangalore**  
Tel: 91-80-3090-4444  
Fax: 91-80-3090-4123

**India - New Delhi**  
Tel: 91-11-4160-8631  
Fax: 91-11-4160-8632

**India - Pune**  
Tel: 91-20-3019-1500

**Japan - Osaka**  
Tel: 81-6-6152-7160  
Fax: 81-6-6152-9310

**Japan - Tokyo**  
Tel: 81-3-6880-3770  
Fax: 81-3-6880-3771

**Korea - Daegu**  
Tel: 82-53-744-4301  
Fax: 82-53-744-4302

**Korea - Seoul**  
Tel: 82-2-554-7200  
Fax: 82-2-558-5932 or  
82-2-558-5934

**Malaysia - Kuala Lumpur**  
Tel: 60-3-6201-9857  
Fax: 60-3-6201-9859

**Malaysia - Penang**  
Tel: 60-4-227-8870  
Fax: 60-4-227-4068

**Philippines - Manila**  
Tel: 63-2-634-9065  
Fax: 63-2-634-9069

**Singapore**  
Tel: 65-6334-8870  
Fax: 65-6334-8850

**Taiwan - Hsin Chu**  
Tel: 886-3-5778-366  
Fax: 886-3-5770-955

**Taiwan - Kaohsiung**  
Tel: 886-7-213-7828

**Taiwan - Taipei**  
Tel: 886-2-2508-8600  
Fax: 886-2-2508-0102

**Thailand - Bangkok**  
Tel: 66-2-694-1351  
Fax: 66-2-694-1350

### EUROPE

**Austria - Wels**  
Tel: 43-7242-2244-39  
Fax: 43-7242-2244-393

**Denmark - Copenhagen**  
Tel: 45-4450-2828  
Fax: 45-4485-2829

**France - Paris**  
Tel: 33-1-69-53-63-20  
Fax: 33-1-69-30-90-79

**Germany - Dusseldorf**  
Tel: 49-2129-3766400

**Germany - Karlsruhe**  
Tel: 49-721-625370

**Germany - Munich**  
Tel: 49-89-627-144-0  
Fax: 49-89-627-144-44

**Italy - Milan**  
Tel: 39-0331-742611  
Fax: 39-0331-466781

**Italy - Venice**  
Tel: 39-049-7625286

**Netherlands - Drunen**  
Tel: 31-416-690399  
Fax: 31-416-690340

**Poland - Warsaw**  
Tel: 48-22-3325737

**Spain - Madrid**  
Tel: 34-91-708-08-90  
Fax: 34-91-708-08-91

**Sweden - Stockholm**  
Tel: 46-8-5090-4654

**UK - Wokingham**  
Tel: 44-118-921-5800  
Fax: 44-118-921-5820

07/14/15