

NTC Thermistor : TSM Series

SMD Type NTC Thermistor for Temperature Sensing



■ Features

1. RoHS & Halogen Free (HF) compliant
2. EIA size: 0201, 0402, 0603, 0805
3. Highly reliable structure
4. Operating temperature range: -40°C~+125°C
5. Wide resistance range
6. Cost effective
7. Agency recognition: UL / cUL / TUV/ CQC

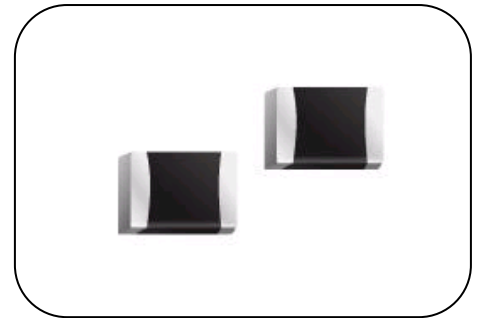

■ Recommended Applications

1. Battery pack
2. Motherboard, notebook and personal computer device
3. Liquid crystal display
4. Cellular phone
5. Bluetooth headset
6. Wi-Fi module

■ Part Number Code

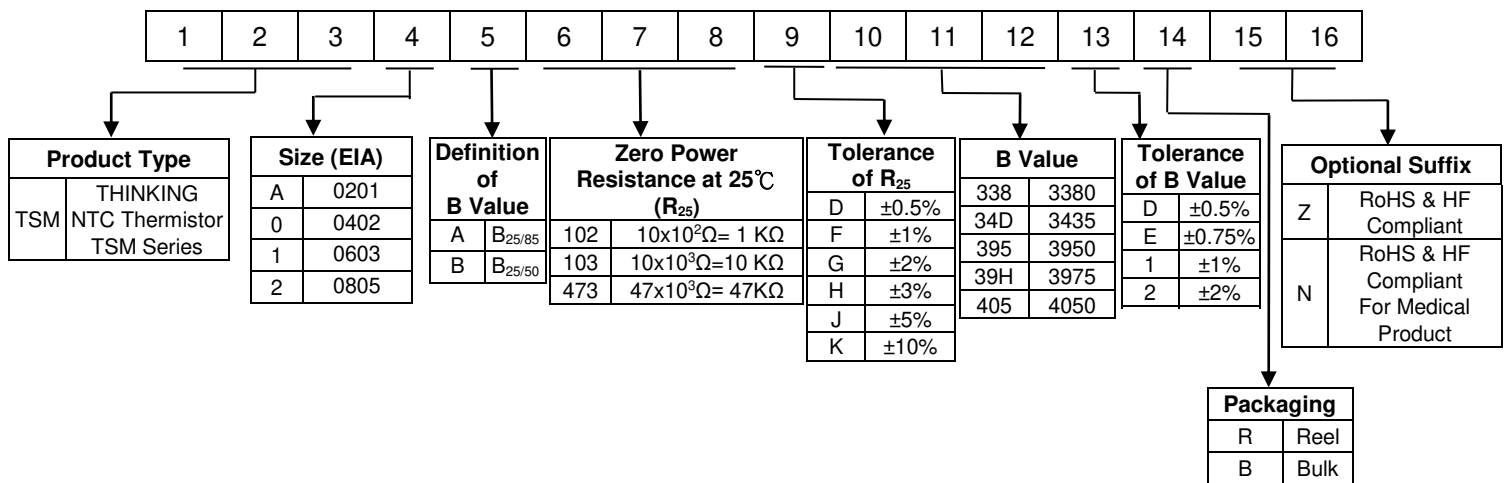

■ Structure and Dimensions

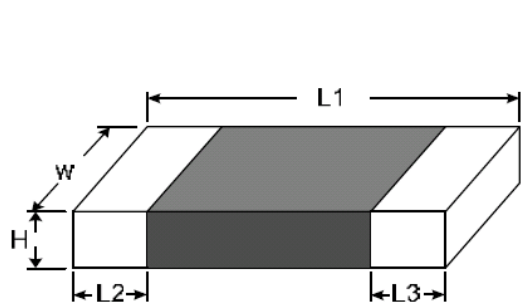

(Unit: mm)

Part No.	Size (EIA)	L1	W	H	L2 & L3
TSM A	0201	0.60±0.03	0.30±0.03	0.30±0.03	0.15±0.05
TSM 0	0402	1.00±0.15	0.50±0.10	0.50±0.10	0.20±0.10
TSM 1	0603	1.60±0.15	0.80±0.15	0.80±0.15	0.40±0.15
TSM 2	0805	2.00±0.20	1.25±0.20	1.00max.	0.40±0.20

NTC Thermistor : TSM Series

SMD Type NTC Thermistor for Temperature Sensing



Electrical Characteristics

Part No.	Size (EIA)	Zero Power Resistance at 25°C	Tolerance of R25	B Value		Tolerance of B value	Max. Power Dissipation at 25°C	Dissipation Factor	Thermal Time Constant	Operating Temperature Range	Safety Approvals			
		R ₂₅ (KΩ)	(±%)	(K)	(±%)	P _{max} (mW)	δ(mW/°C)	τ (Sec.)	T _L ~T _U (°C)	UL cUL	TUV	CQC		
TSMAB103□338*	0201	10	1, 2, 3, 5, 10	25/50	3380	1, 2, 3	100	Approx. 1.4	Approx. 1.2	-40 ~ +125	✓	✓	✓	
TSMAB473□405*		47			4050						✓	✓	✓	
TSMAB683□425*		68			4250						✓	✓	✓	
TSMAB104□425*		100			4250						✓	✓	✓	
TSMAB224□44J		220			4485						✓	✓	✓	
TSM0A103□34D*	0402	10	1, 2, 3, 5, 10	25/85	3435	1, 2, 3	170	Approx. 1.7	Approx. 2.0	-40 ~ +125	✓	✓	✓	
TSM0A103□395*		10			3950						✓	✓	✓	
TSM0A223□395*		22			3950						✓	✓	✓	
TSM0A473□395*		47			3950						✓	✓	✓	
TSM0A683□410*		68			4100						✓	✓	✓	
TSM0A104□405*		100			4050						✓	✓	✓	
TSM0A104□436*		100			4360						✓	✓	✓	
TSM0A224□475*		220			4750						✓	✓	✓	
TSM0B103□338*		10	0.5,1, 2,3, 5, 10	25/50	3380	0.75,1, 2, 3					✓	✓	✓	
TSM0B473□405*		47	1, 2, 3, 5, 10		4050	1, 2, 3					✓	✓	✓	
TSM0B104□425*		100	0.5,1, 2,3, 5, 10		4250	0.5,1, 2, 3					✓	✓	✓	
TSM0B104□436*		100	1, 2, 3, 5, 10		4360	1, 2, 3					✓	✓	✓	
TSM0B224□470*		220	2, 3, 5, 10		4700	1, 2, 3					✓	✓	✓	
TSM0A103□430*		10	3, 5, 10	25/85	4300	2,3					100	✓	✓	✓
TSM0B102□365*		1	5,10	25/50	3650							✓	✓	✓
TSM0B474□470*	470	3, 5, 10	4700		✓		✓	✓						
TSM1A202□340*	0603	2	1, 2, 3, 5, 10	25/85	3400	1, 2, 3	210	Approx. 2.1	Approx. 3.1	-40~+125	✓	✓	✓	
TSM1A472□34D*		4.7			3435						✓	✓	✓	
TSM1A472□370*		4.7			3700						✓	✓	✓	
TSM1A502□34D*		5			3435						✓	✓	✓	
TSM1A502□385*		5			3850						✓	✓	✓	
TSM1A682□34D*		6.8			3435						✓	✓	✓	
TSM1A103□34D*		10			3435						✓	✓	✓	
TSM1A103□39H*		10			3975						✓	✓	✓	
TSM1A223□395*		22			3950						✓	✓	✓	
TSM1A333□395*		33			3950						2, 3	✓	✓	✓
TSM1A473□39H*		47			3975	1, 2, 3					✓	✓	✓	
TSM1A503□400*		50			4000						✓	✓	✓	
TSM1A683□400*		68			4000						✓	✓	✓	
TSM1A104□39H*		100			3975						✓	✓	✓	
TSM1A104□405*		100			4050						✓	✓	✓	
TSM1A104□436*		100			4360						✓	✓	✓	
TSM1A154□406*		150			4060						✓	✓	✓	
TSM1A204□410*		200			4100						✓	✓	✓	
TSM1A474□415*		470			4150						2, 3	✓	✓	✓

Note 1: □ = Tolerance of R₂₅ * = Tolerance of B value

Note 2: UL&cUL File No. E138827 / TUV File No. R 50167657 / CQC File No.12001080962

Note 3: Special specifications are available upon request

NTC Thermistor : TSM Series

SMD Type NTC Thermistor for Temperature Sensing



Electrical Characteristics

Part No.	Size (EIA)	Zero Power Resistance at 25°C	Tolerance of R25	B Value	Tolerance of B value	Max. Power Dissipation at 25°C	Dissipation Factor	Thermal Time Constant	Operating Temperature Range	Safety Approvals		
		R ₂₅ (KΩ)	(±%)	(K)	(±%)	P _{max} (mW)	δ(mW/°C)	τ (Sec.)	T _L ~T _U (°C)	UL cUL	TUV	CQC
TSM1B332□365*	0603	3.3	1, 2, 3,	3650	1, 2, 3	210	Approx. 2.1	Approx. 3.1	-40~+125	√	√	√
TSM1B682□395*		6.8	5, 10							3950	√	√
TSM1B103□338*		10	0.5,1, 2,3, 5, 10	3380	0.75,1, 2, 3					√	√	√
TSM1B103□420*		10	1, 2, 3, 5, 10	4200	1, 2, 3					√	√	√
TSM1B473□425*		47		4250						√	√	√
TSM1B104□359*		100		3590						√	√	√
TSM1B104□425*		100	0.5, 1, 2, 3, 5, 10	4250	0.5, 1, 2, 3					√	√	√
TSM1B224□450*		220	1, 2, 3, 5, 10	4500	1, 2, 3					√	√	√
TSM1B222□395*		2.2	3, 5, 10	3950	2, 3					√	√	√
TSM1B682□425*		6.8	5, 10	4250	3					√	√	√
TSM2A102□320*	0805	1	1, 2, 3, 5, 10	3200	1, 2, 3	240	Approx. 2.4	Approx. 5.4	-40~+125	√	√	√
TSM2A222□345*		2.2		3450						√	√	√
TSM2A 502□34D*		5		3435						√	√	√
TSM2A682□34D*		6.8		3435						√	√	√
TSM2A103□34D*		10		3435						√	√	√
TSM2A103□373*		10		3730						√	√	√
TSM2A103□395*		10		3950						√	√	√
TSM2A223□396*		22		3960						√	√	√
TSM2A333□400*		33		4000						√	√	√
TSM2A473□400*		47		4000						√	√	√
TSM2A104□400*		100		4000						√	√	√
TSM2A104□455*		100		4550						√	√	√
TSM2A334□41H*		330		4175						√	√	√
TSM2B103□395*		10		3950						√	√	√
TSM2B104□425*		100		4250						√	√	√

Note 1: □ = Tolerance of R₂₅
 * = Tolerance of B value

Note 2: UL&cUL File No. E138827 / TUV File No. R 50167657 / CQC File No.12001080962

Note 3: Special specifications are available upon request

NTC Thermistor : TSM Series

SMD Type NTC Thermistor for Temperature Sensing



Max. Power Dissipation Derating Curve

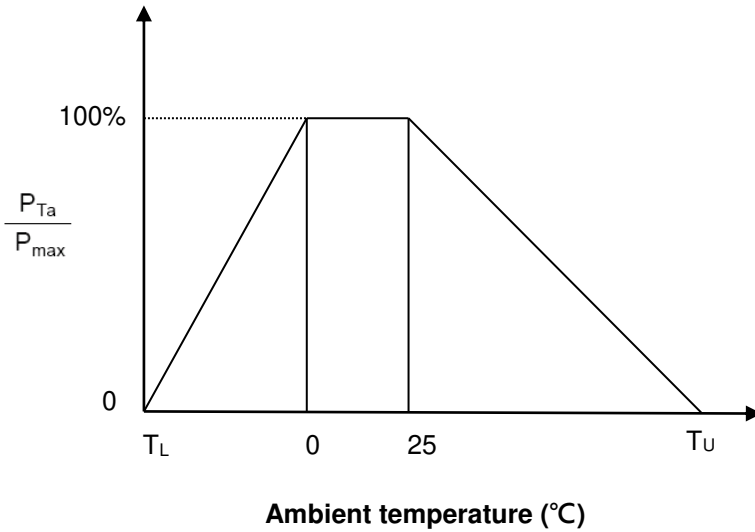

T_U : Maximum operating temperature (°C)

T_L : Minimum operating temperature (°C)

For example:

Ambient temperature (T_a) = 55°C

Maximum operating temperature (T_U) = 125°C

$$P_{Ta} = \frac{(T_U - T_a)}{(T_U - 25)} \times P_{max} = 70\% P_{max}$$

R-T Characteristic Curves

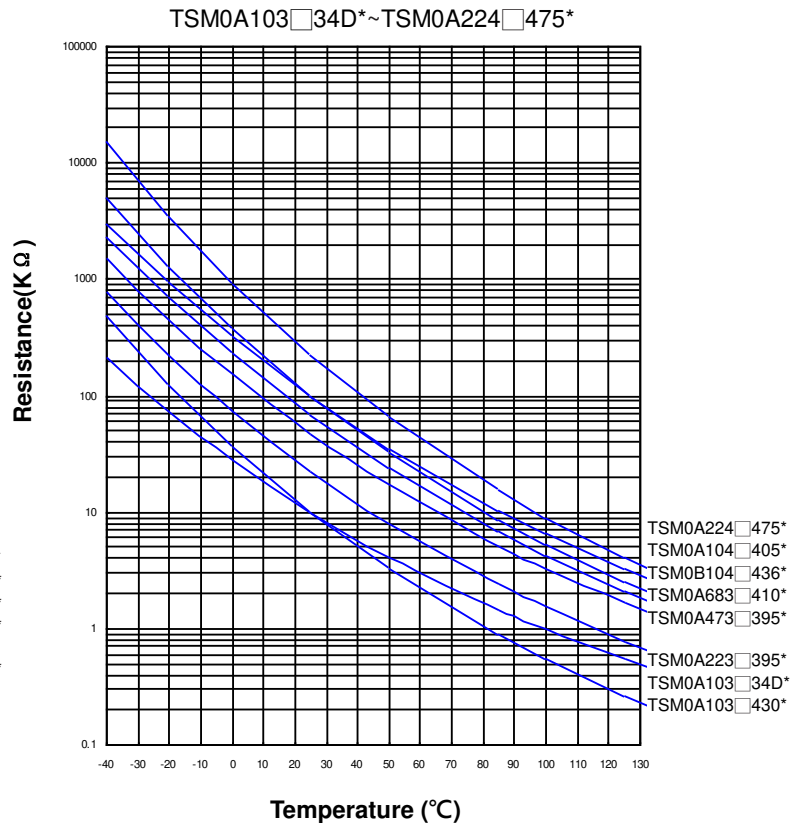
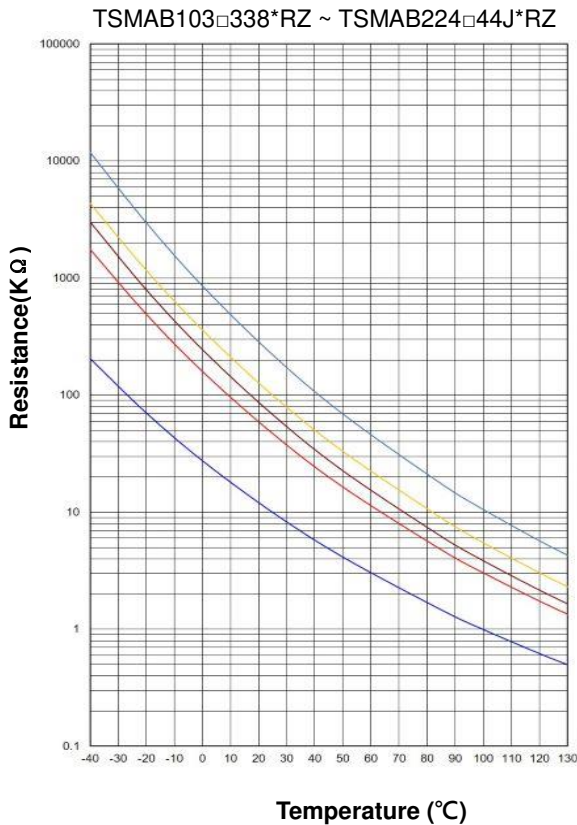

NTC Thermistor : TSM Series

SMD Type NTC Thermistor for Temperature Sensing



R-T Characteristic Curves

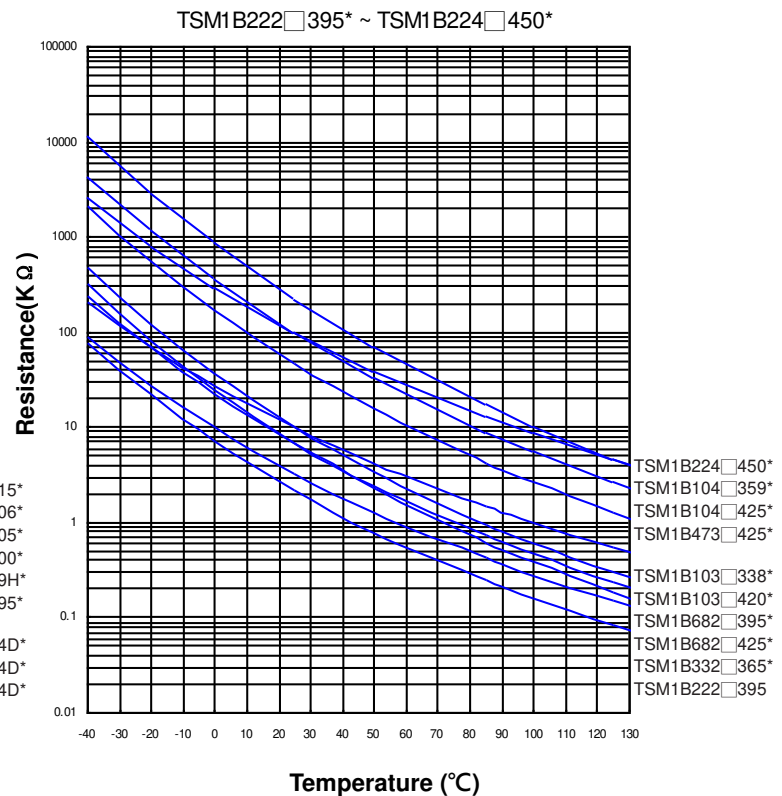
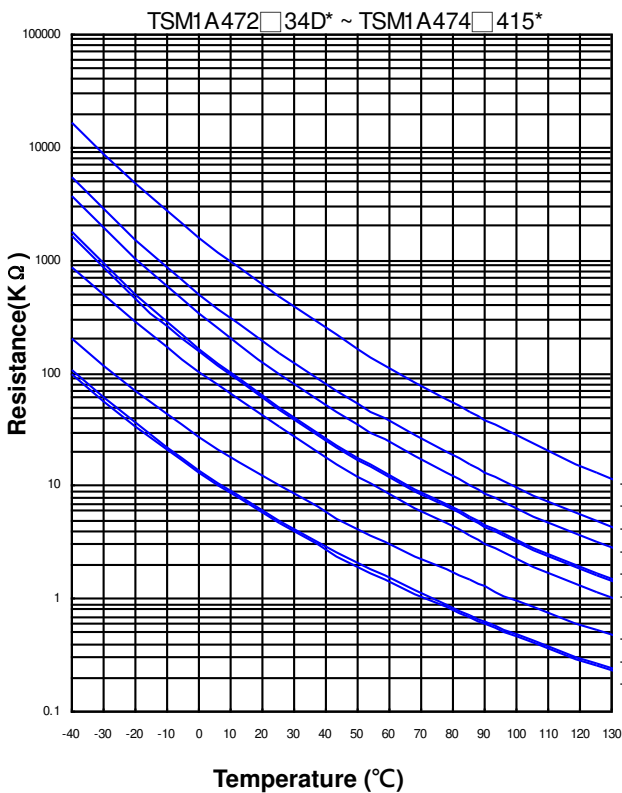
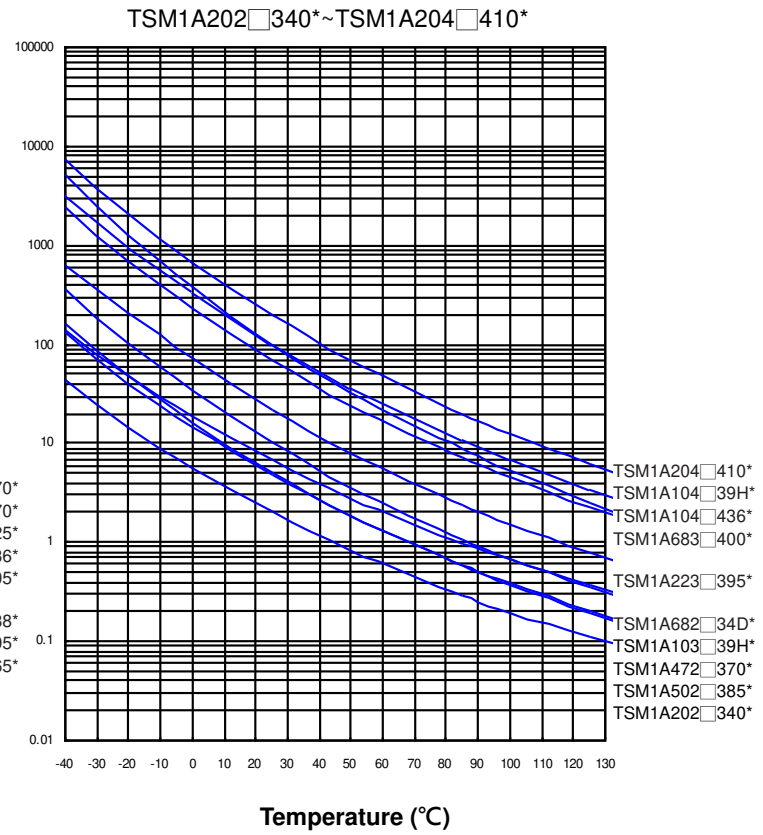
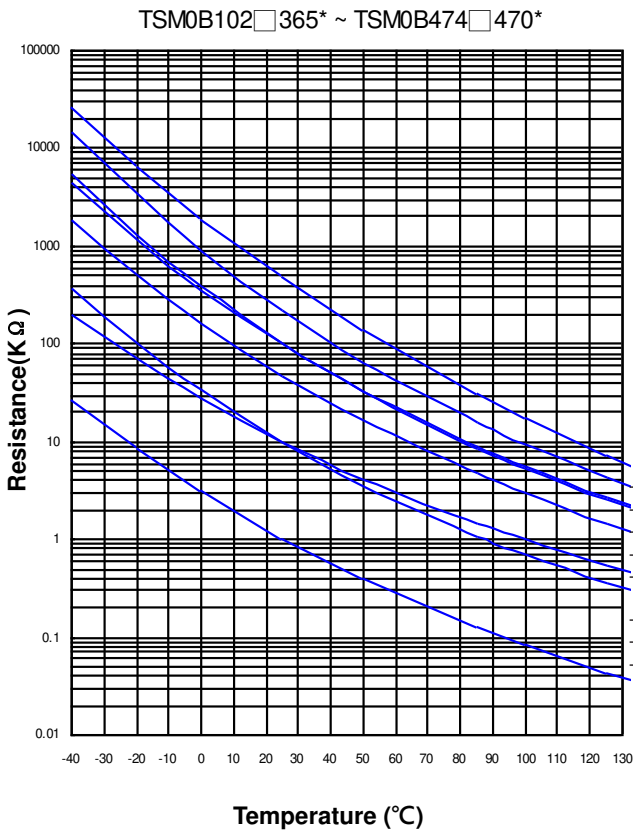

NTC Thermistor : TSM Series

SMD Type NTC Thermistor for Temperature Sensing



R-T Characteristic Curves

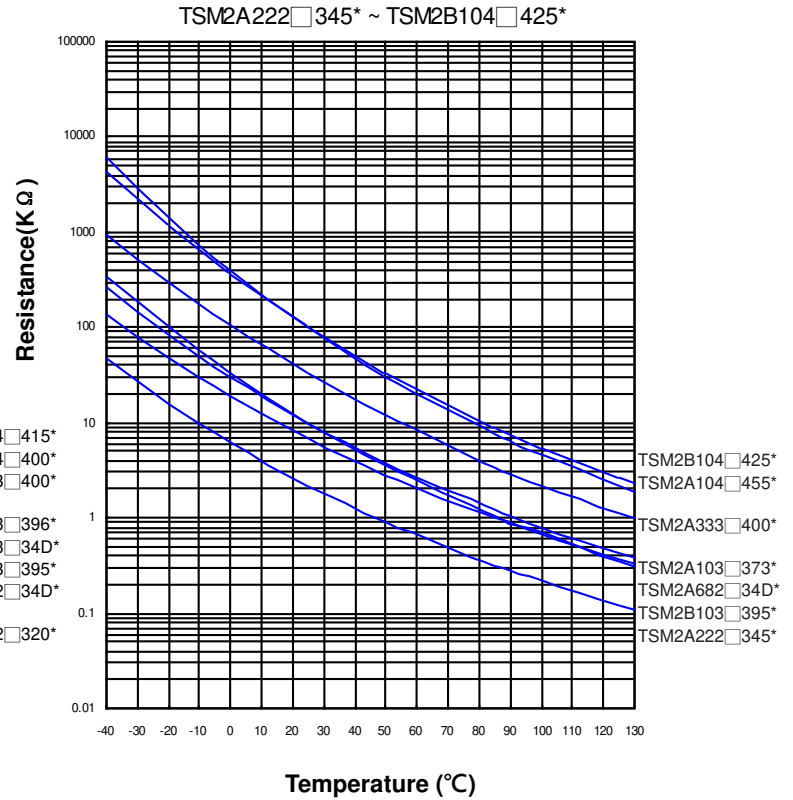
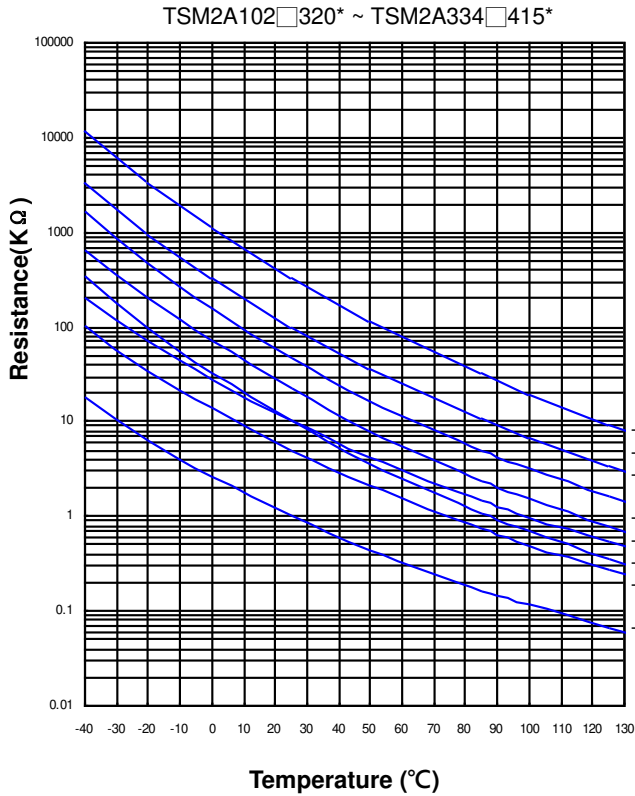

Soldering Recommendation

● IR-Reflow Soldering Profile

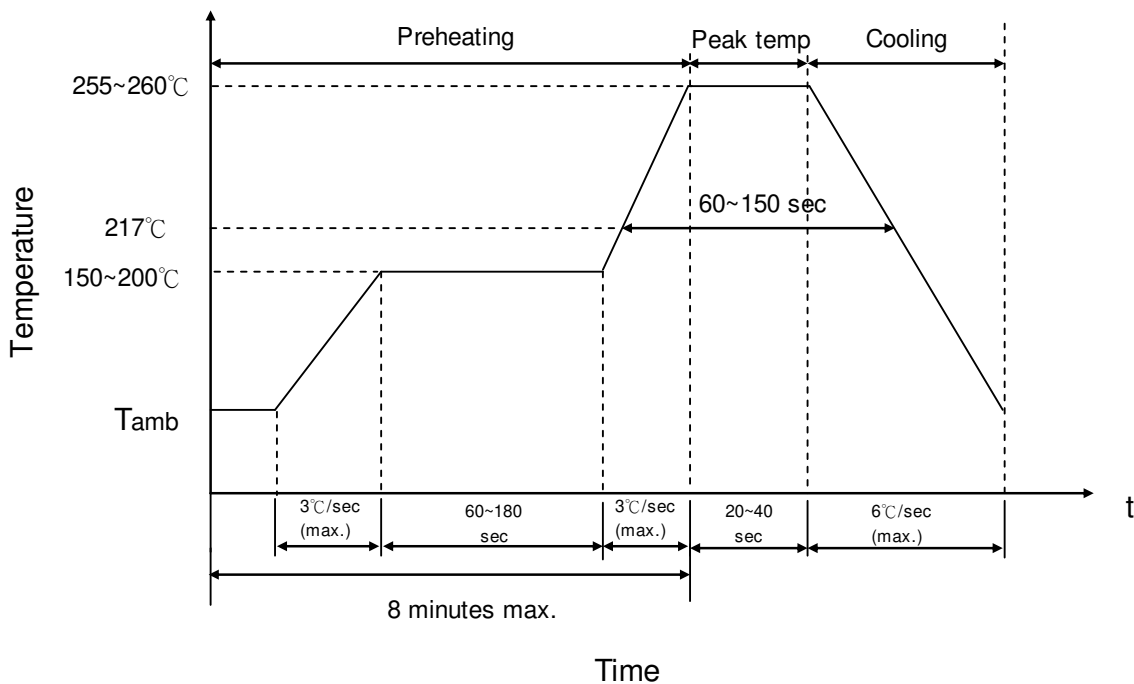

NTC Thermistor : TSM Series

SMD Type NTC Thermistor for Temperature Sensing



- Recommended Reworking Conditions with Soldering Iron

Item	Conditions
Temperature of Soldering Iron-tip	360°C (max.)
Soldering Time	3 sec. (max.)
Diameter of Soldering Iron-tip	Φ3mm (max.)

Caution: Please do not touch the component surface with soldering iron directly to avoid its damage.

- Recommended Soldering Pad Dimensions

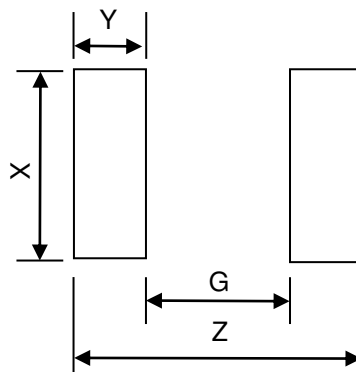

Size (EIA)	Z (mm)	G (mm)	X (mm)	Y (mm)
0201	0.8	0.3	0.3	0.25
0402	1.7	0.5	0.6	0.6
0603	2.8	0.8	1.0	1.0
0805	3.4	1.0	1.4	1.2

NTC Thermistor : TSM Series

SMD Type NTC Thermistor for Temperature Sensing



■ Notice of Soldering and Mounting on PC Board

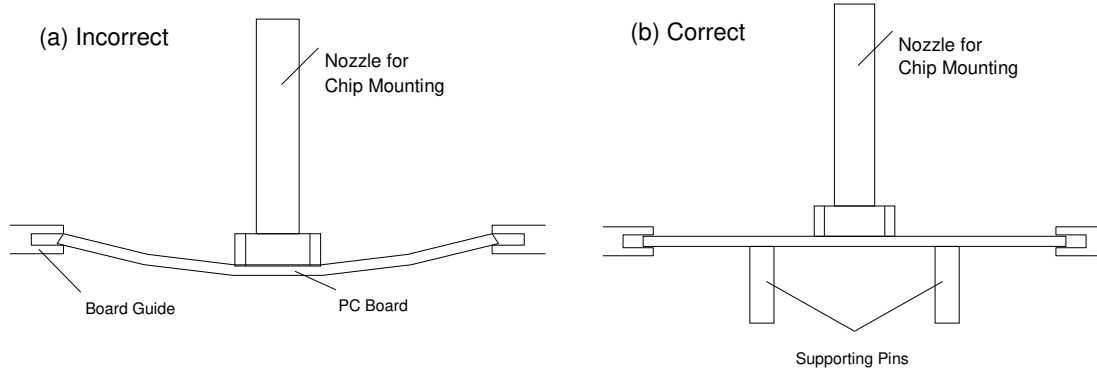

For mounting SMDs on a PC board, supporting pin is suggested for use (refer to figure b) to avoid cracks caused by external stress (refer to figure a).

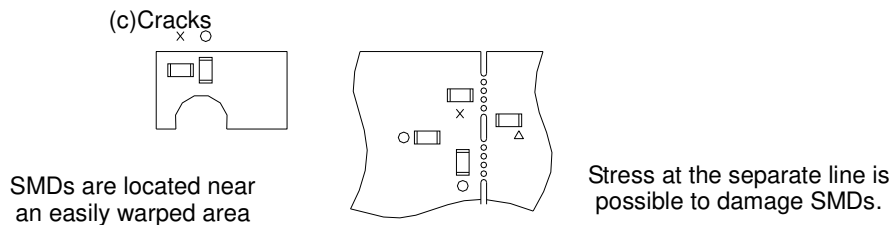

If circuit bending is needed for PC board design, please refer to figure (c) for mounting positions to avoid cracks caused by stress imposed on the product. O means better, Δ is acceptable, and X is worst.

(d) Component Orientation

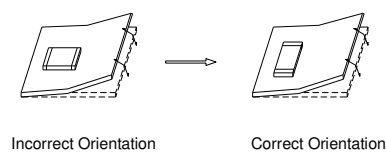

Locate SMDs horizontally to the direction that stress acts

During circuit bending, please locate SMDs horizontally to the direction in which stress act to avoid its cracks (refer to figure d).

NTC Thermistor : TSM Series

SMD Type NTC Thermistor for Temperature Sensing



■ Reliability

Item	Standard	Test conditions / Methods	Specifications															
Bending Strength	IEC 60068-2-21	Warp : 2mm for 0402,0603 and 0805 1mm for 0201 Speed < 0.5mm/sec. Duration: 10 sec. on PCB	No visible damage $\Delta R_{25}/R_{25}$ $\leq 5\%$															
Solderability	IEC 60068-2-58	245 \pm 5°C, 3 \pm 0.3 sec.	At least 95% of terminal electrode is covered by new solder															
Resistance to Soldering Heat	IEC 60068-2-58	260 \pm 5°C, 10 \pm 1 sec.	No visible damage $\Delta R_{25}/R_{25}$ $\leq 3\%$															
High Temperature Storage	IEC 60068-2-2	125 \pm 5°C, 1000 \pm 24 hrs	No visible damage $\Delta R_{25}/R_{25}$ $\leq 5\%$															
Damp Heat, Steady State	IEC 60068-2-78	40 \pm 2°C, 90~95% RH , 1000 \pm 24 hrs	No visible damage $\Delta R_{25}/R_{25}$ $\leq 3\%$															
Rapid Change of Temperature	IEC 60068-2-14	The conditions shown below shall be repeated 5 cycles on PCB. <table border="1" style="margin-left: auto; margin-right: auto;"> <thead> <tr> <th>Step</th> <th>Temperature (°C)</th> <th>Period (minutes)</th> </tr> </thead> <tbody> <tr> <td>1</td> <td>-40 \pm 5</td> <td>30 \pm 3</td> </tr> <tr> <td>2</td> <td>Room temperature</td> <td>5 \pm 3</td> </tr> <tr> <td>3</td> <td>125 \pm 5</td> <td>30 \pm 3</td> </tr> <tr> <td>4</td> <td>Room temperature</td> <td>5 \pm 3</td> </tr> </tbody> </table>	Step	Temperature (°C)	Period (minutes)	1	-40 \pm 5	30 \pm 3	2	Room temperature	5 \pm 3	3	125 \pm 5	30 \pm 3	4	Room temperature	5 \pm 3	No visible damage $\Delta R_{25}/R_{25}$ $\leq 3\%$
Step	Temperature (°C)	Period (minutes)																
1	-40 \pm 5	30 \pm 3																
2	Room temperature	5 \pm 3																
3	125 \pm 5	30 \pm 3																
4	Room temperature	5 \pm 3																
Max. Power Dissipation	IEC 60539-1 4.26.3	25 \pm 5°C, Pmax. , 1000 \pm 24 hrs	No visible damage $\Delta R_{25}/R_{25}$ $\leq 5\%$															

NTC Thermistor : TSM Series

SMD Type NTC Thermistor for Temperature Sensing



Packaging

● Taping Specification

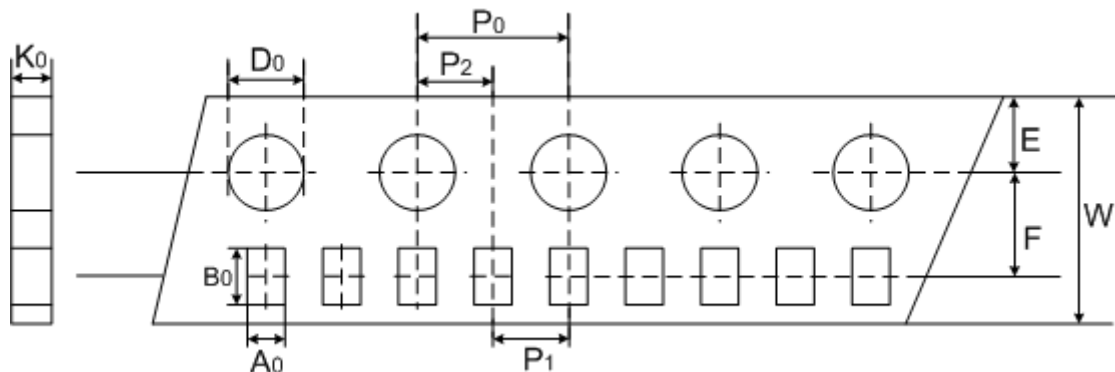

(Unit: mm)

Index Size	A ₀	B ₀	W	E	F	P ₁	P ₂	P ₀	D ₀	K ₀
0201	±0.05	±0.12	±0.2	±0.1	±0.05	±0.1	±0.05	±0.1	±0.1	±0.1
0402	0.62	1.12	8	1.75	3.5	2	2	4	1.55	0.60

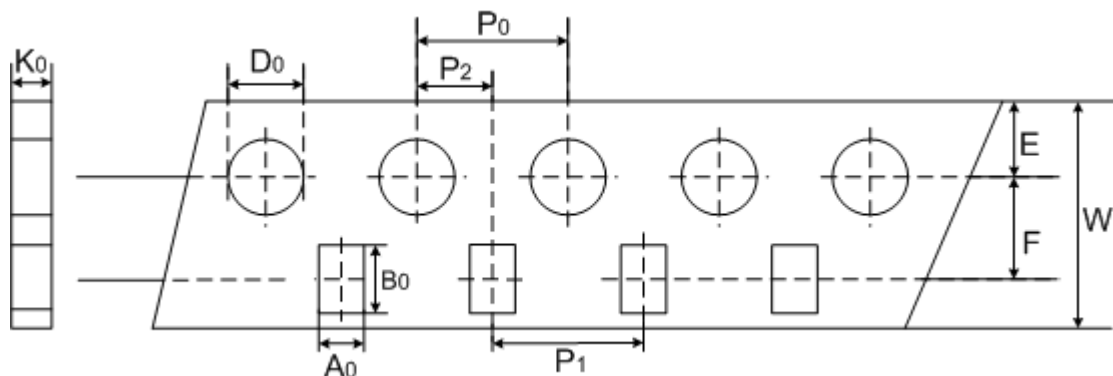

(Unit: mm)

Index Size	A ₀	B ₀	W	E	F	P ₁	P ₂	P ₀	D ₀	K ₀
0603	±0.2	±0.2	±0.2	±0.1	±0.05	±0.1	±0.05	±0.1	±0.1	±0.1
0805	1.5	2.3	8	1.75	3.5	4	2	4	1.55	1.0

NTC Thermistor : TSM Series

SMD Type NTC Thermistor for Temperature Sensing



■ Quantity

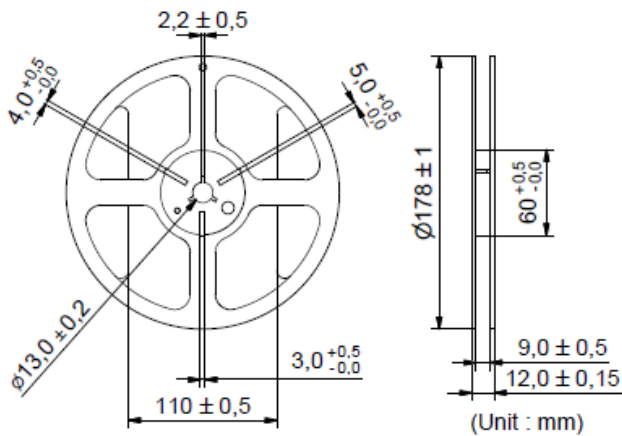

Size (EIA)	Quantity (pcs/reel)
0201	15,000
0402	10,000
0603	4,000
0805	3,500

■ Warehouse Storage Conditions of Products

■ Storage Conditions :

1. Storage Temperature: $-10^{\circ}\text{C} \sim +40^{\circ}\text{C}$
2. Relative Humidity: $\leq 75\% \text{RH}$
3. Keep away from corrosive atmosphere and sunlight.

■ Period of Storage : 1 year